

**pete cornish  
musical  
accessories**

**unit 306,  
164/180 union street,  
london, SE1 OLH.  
tel: 01 928 2670.**

OUT OF POCKET PRODUCTIONS.

GUITAR/EFFECTS/ROUTING SYSTEM UNIT #2

S/No:232      APRIL 1992

INPUT

D3F

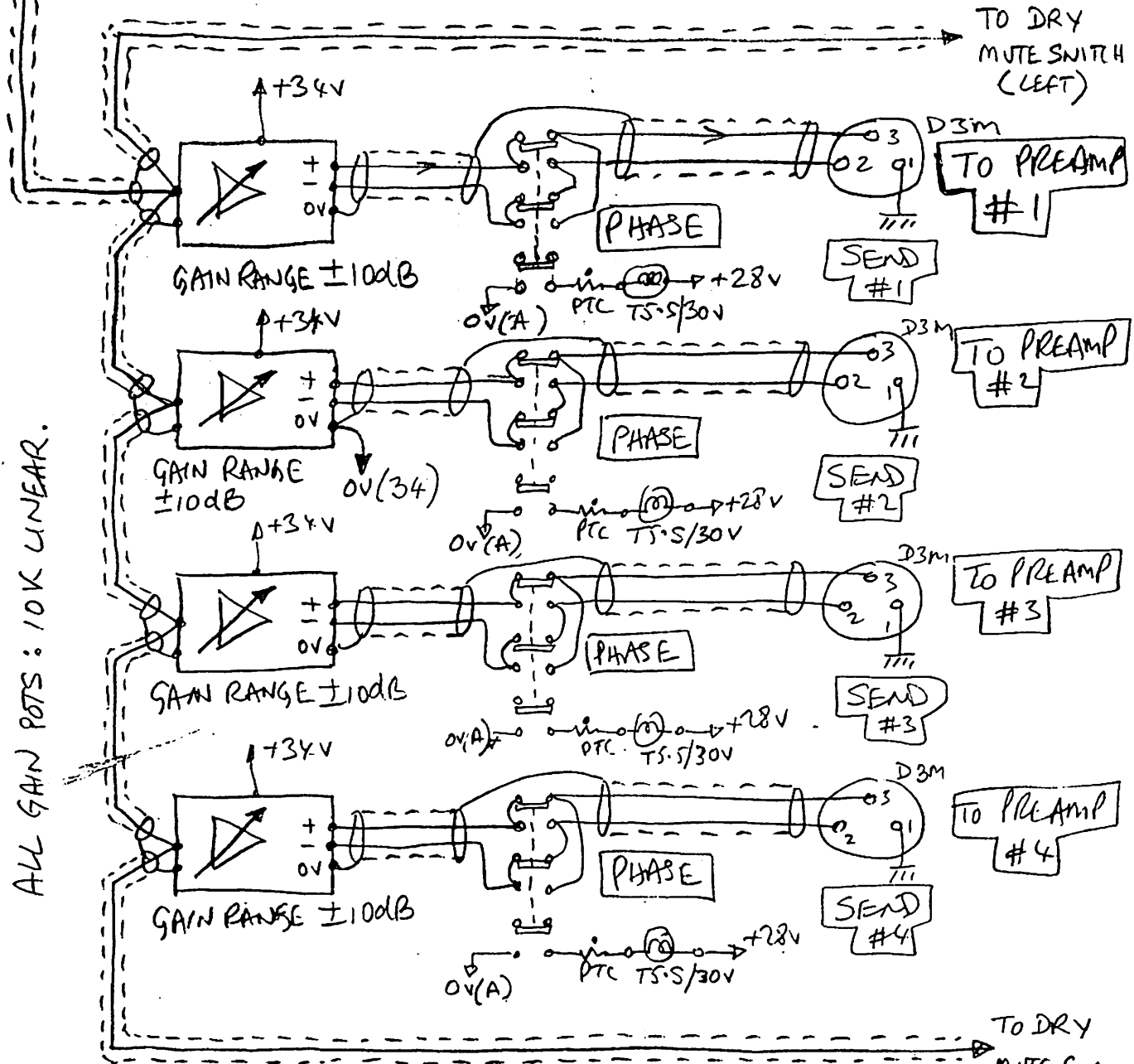
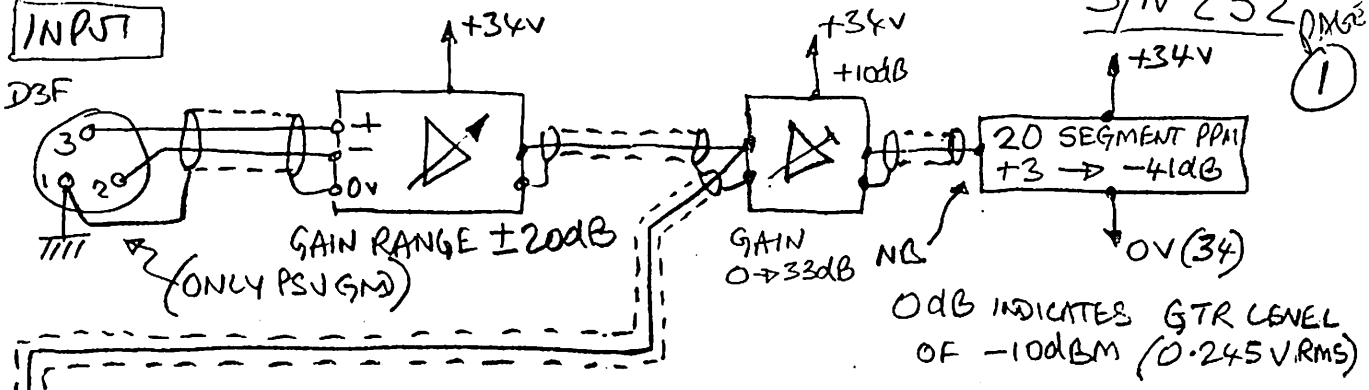

ALL GAIN POTS: 10K LINEAR.

ALL PHASE REVERSE SWITCHES:-

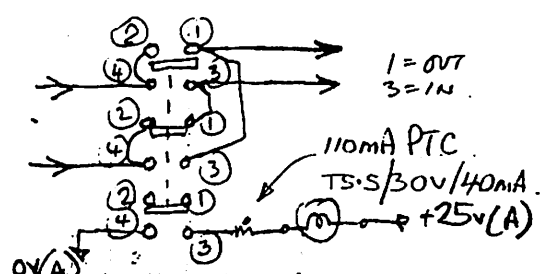

1=OUT  
3=IN

110mA PTC  
TS.S/30V/40mA  
+25V(A)

DRY FROM I/P

DRY MUTE L

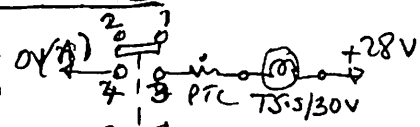

FROM PRE-AMP #1

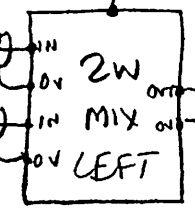
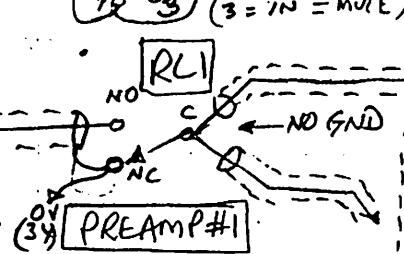
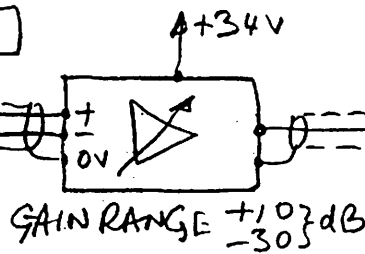
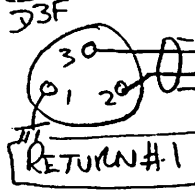

FROM PRE-AMP 2

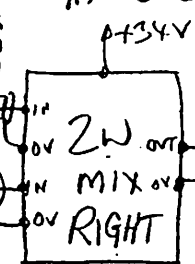
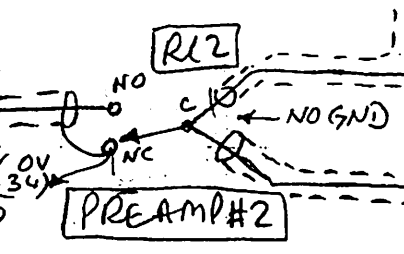
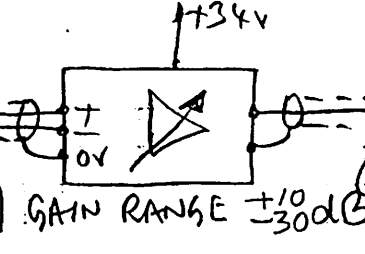
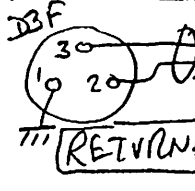

FROM PRE-AMP 3

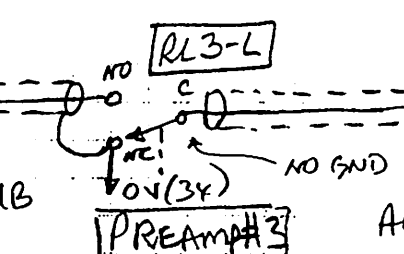
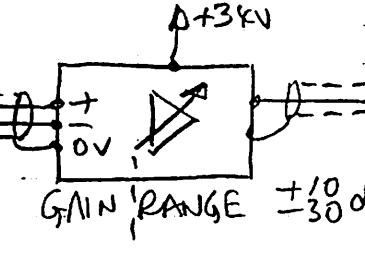
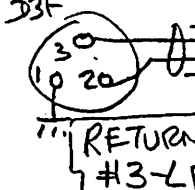

ALL GAIN PTS:  
10K LINEAR

FROM PRE-AMP 3

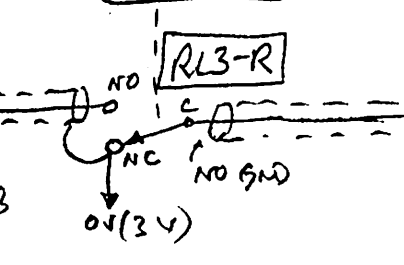
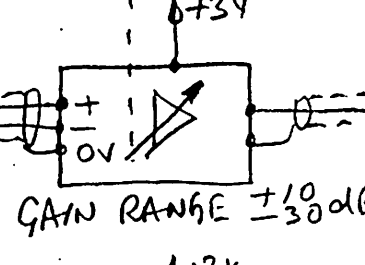

(TO 4W MIX  
L+R)

FROM PRE-AMP 4

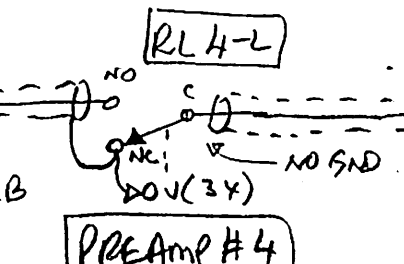
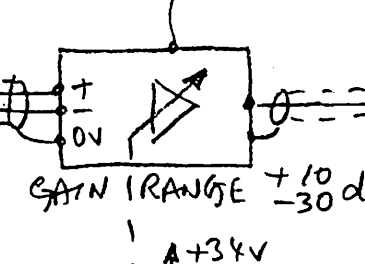
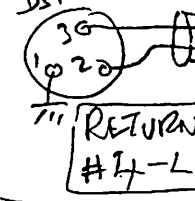

FROM PRE-AMP 4

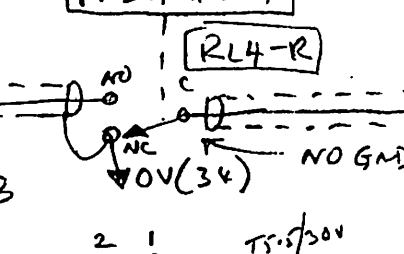
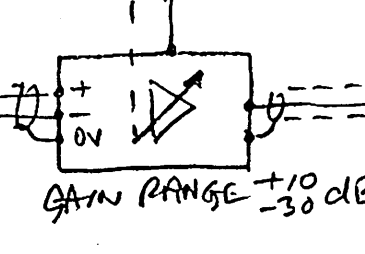
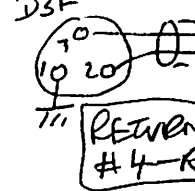

DRY FROM I/P

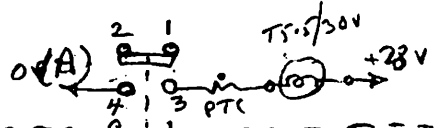

DRY MUTE R

3 = IN = MUTE

FROM DRYMUTEL SWITCH

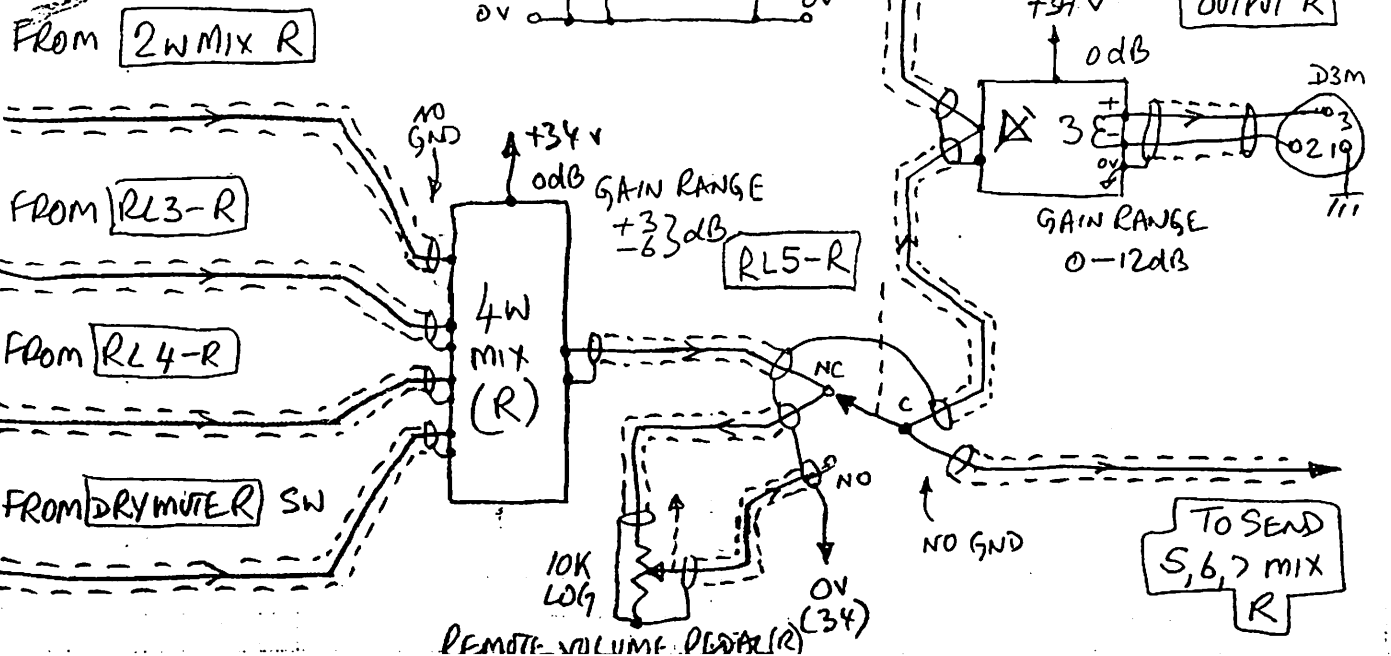
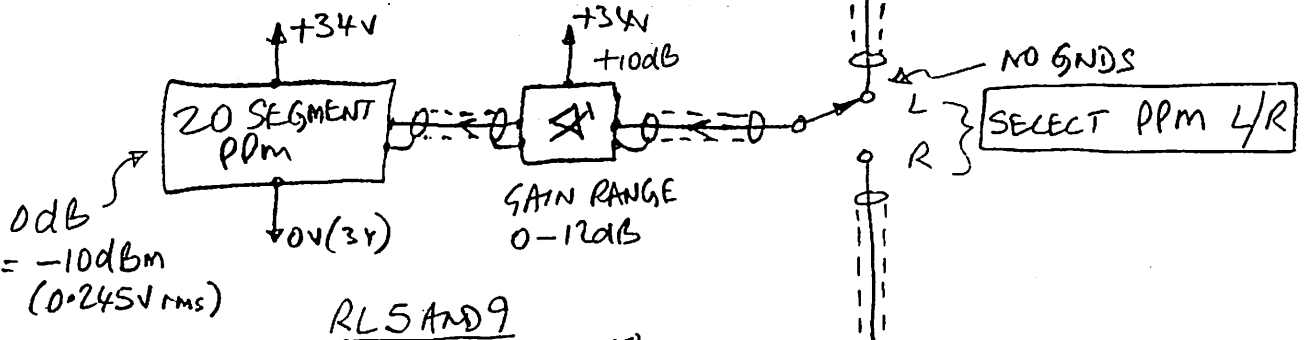
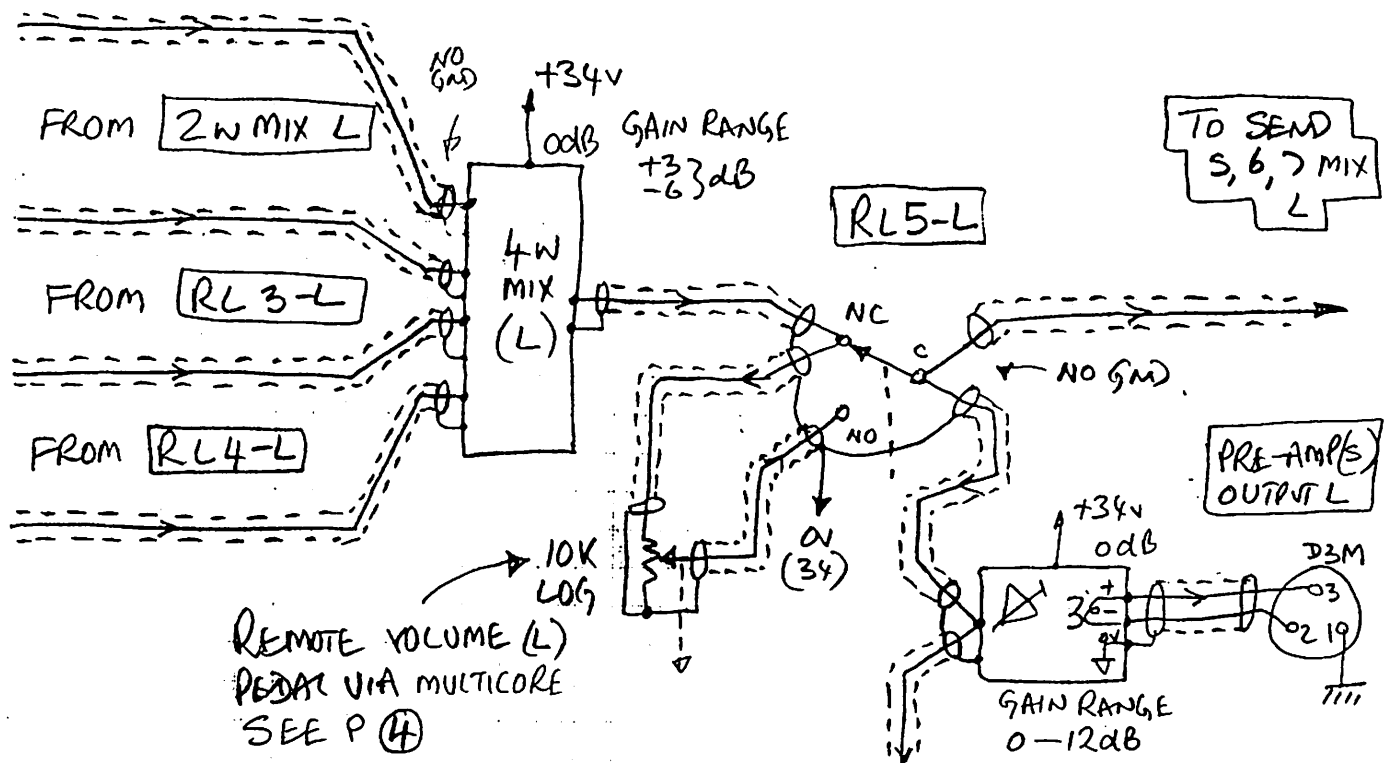

REMOTE VOLUME PEDAL

(4)

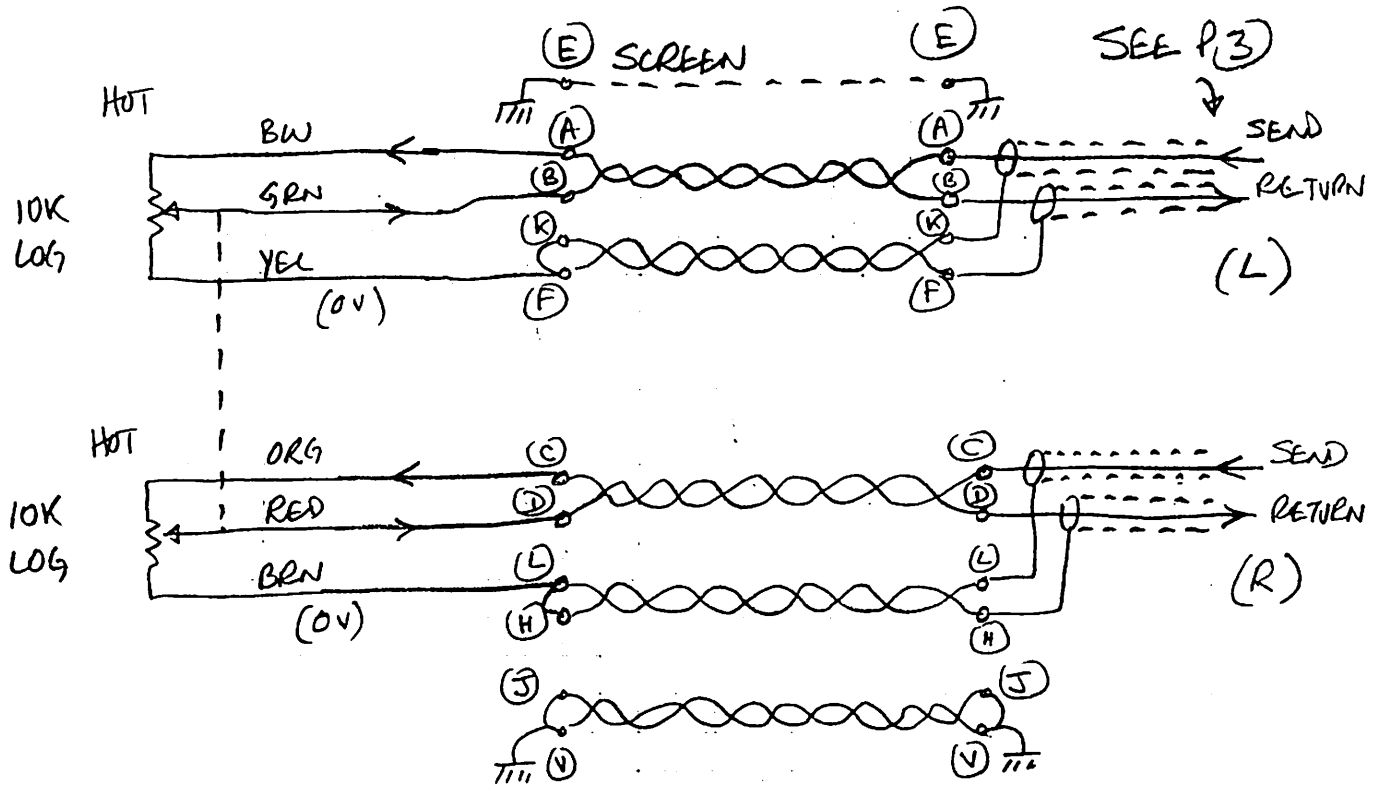

CABLE: BEUDEN 9505 (5 PR + FOIL SCREEN) : 15ft.

PLUGS + SOCKETS: EDAC 20 W (PIN NOS AS ABOVE)

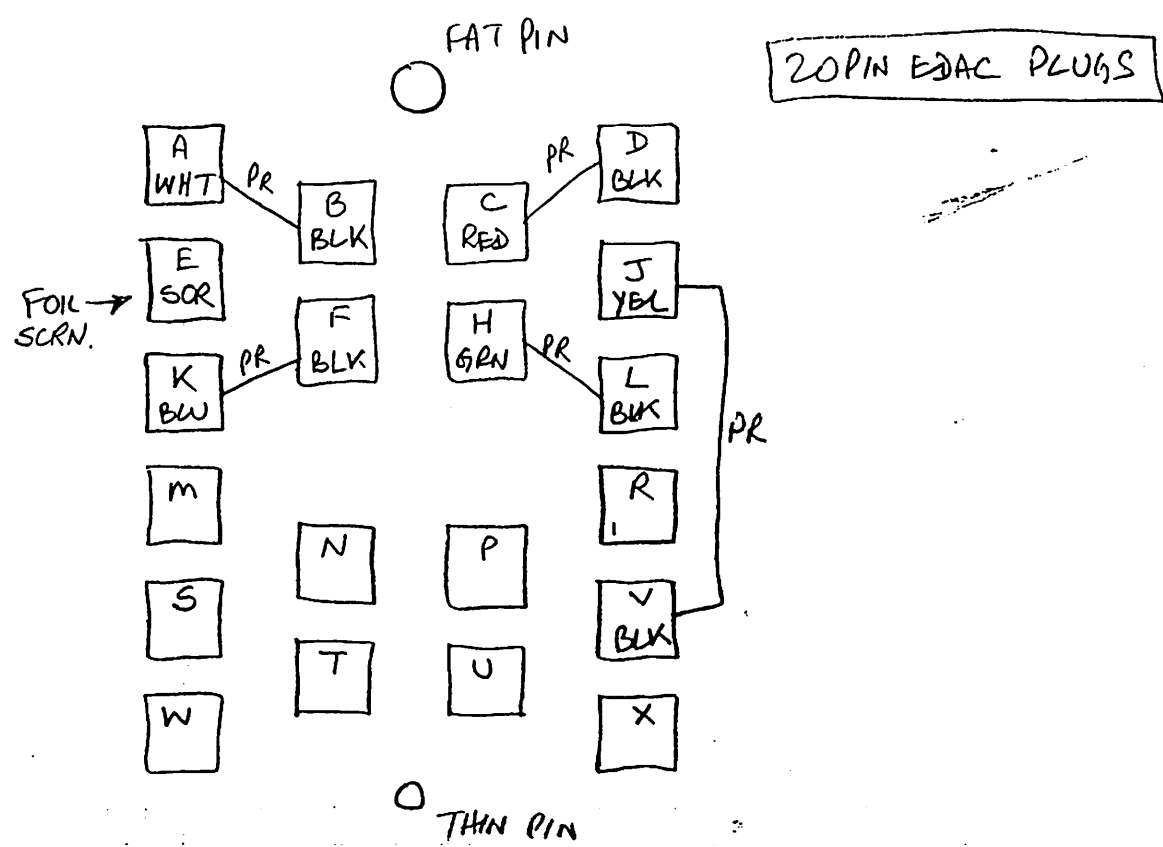

FROM RL5-L(C) [P3]

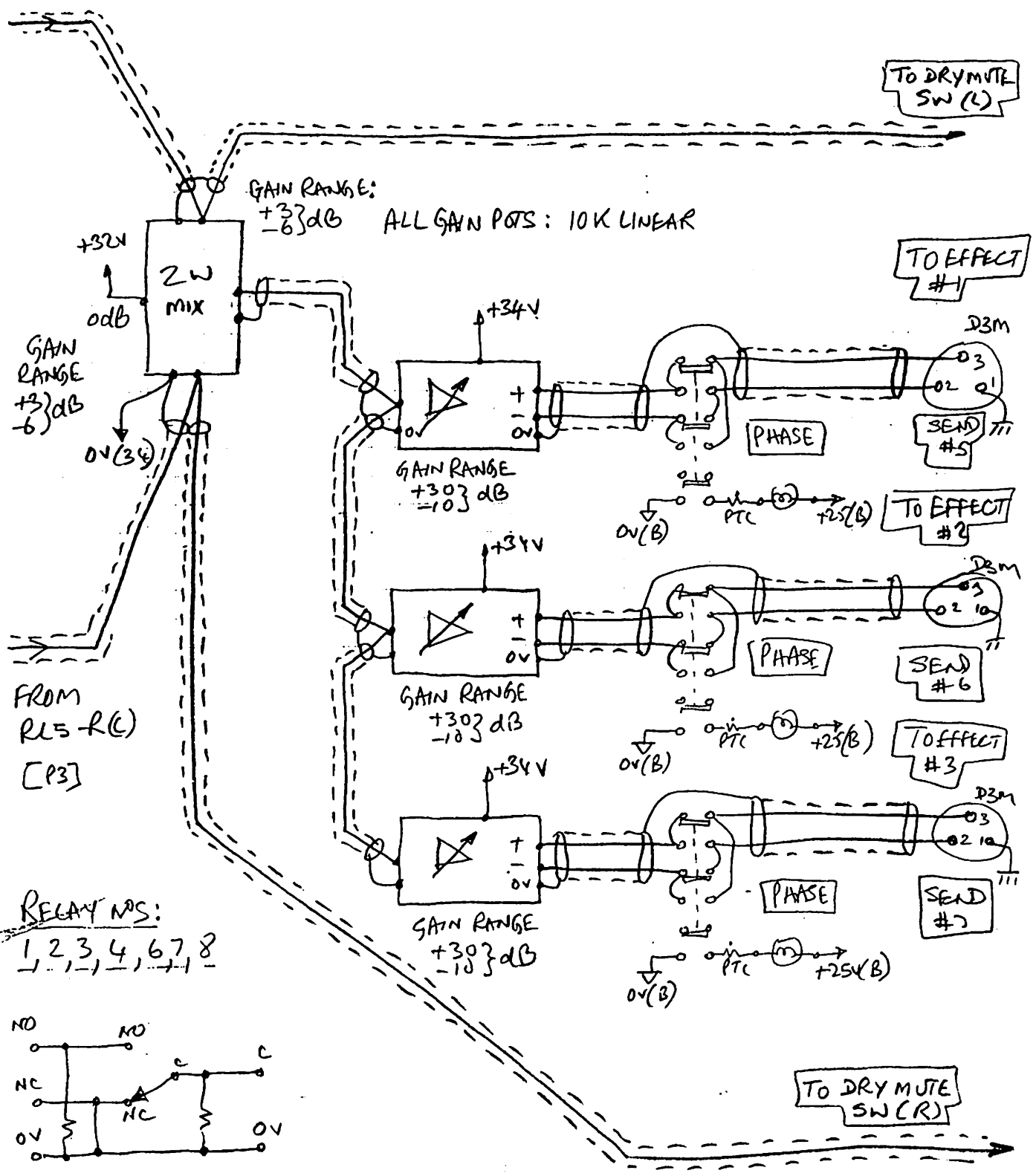

GAIN RANGE +3 -6 dB

GAIN RANGE: +3 -6 dB ALL GAIN POTS: 10K LINEAR

GAIN RANGE +30 -10 dB

GAIN RANGE +30 -10 dB

GAIN RANGE +30 -10 dB

FROM RL5-R(C) [P3]

RELAY NOS:  
1 2 3 4 6 7 8  
- - - - - + + -

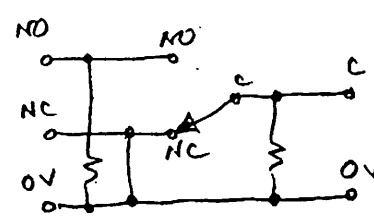

ALL PHASE REVERSE SWITCHES:

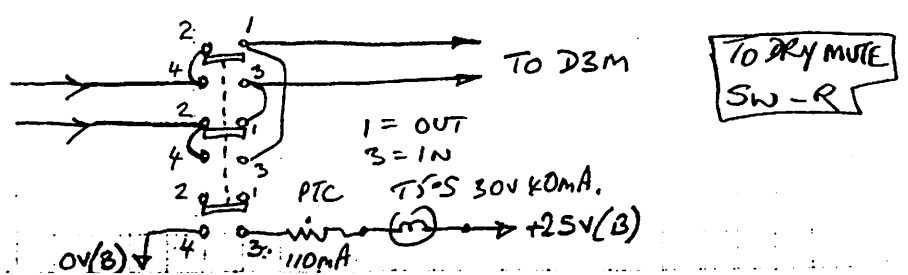

(6)

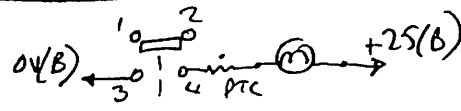

FROM EFFECT 1-L

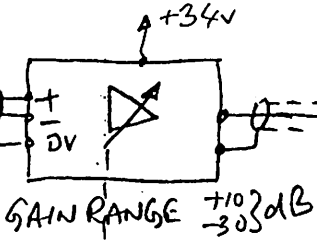

RL6-L

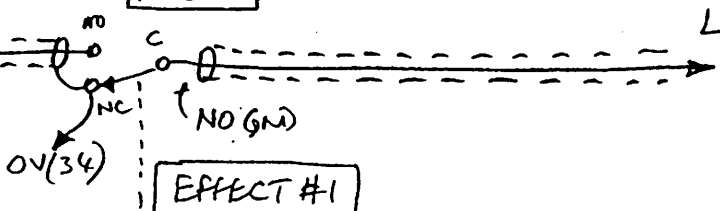

FROM EFFECT 1-R

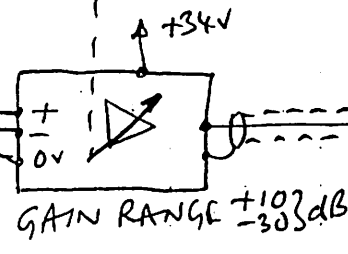
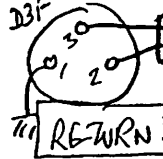

RL6-R

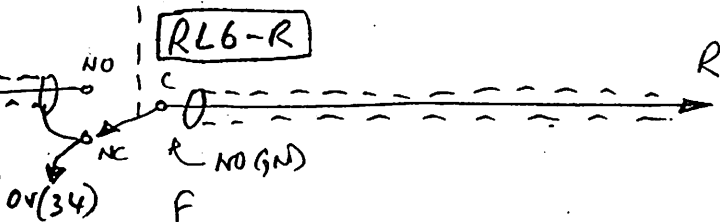

FROM EFFECT 2-L

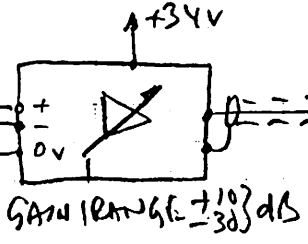
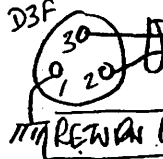

RL7-L

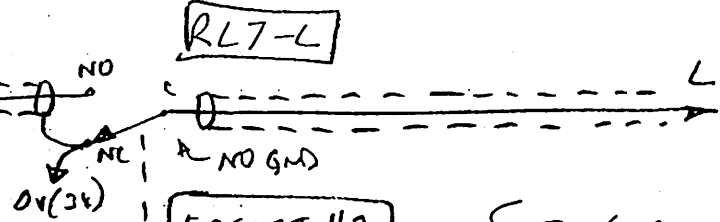

FROM EFFECT 2-R

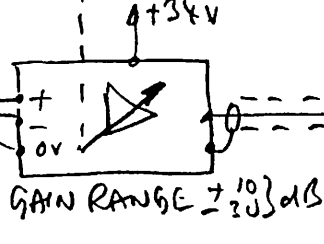
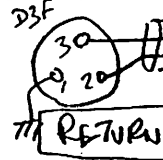

RL7-R

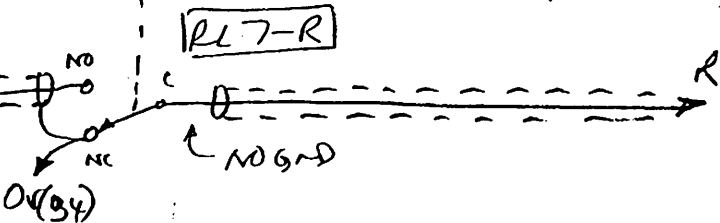

[ TO 4W MIX L+R ]

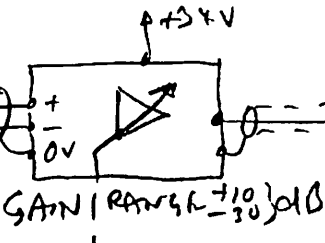
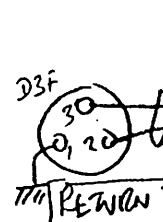

RL8-L

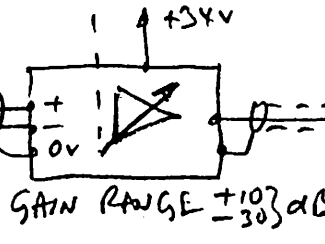
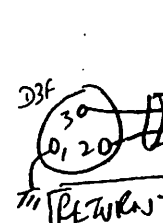
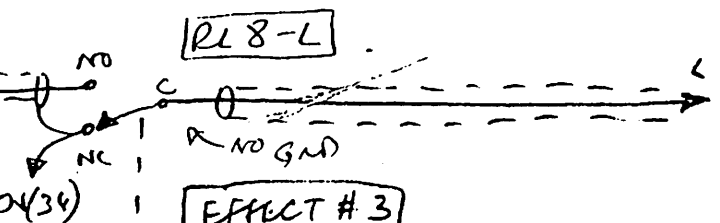

RL8-R

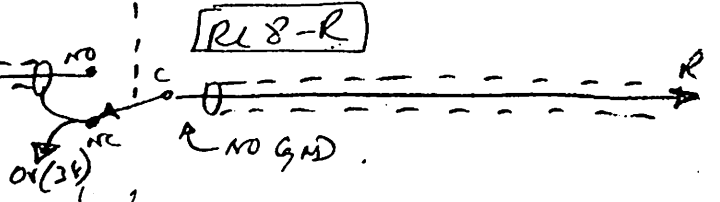

NO GND

FROM DRYMUTE-LEFT SW.

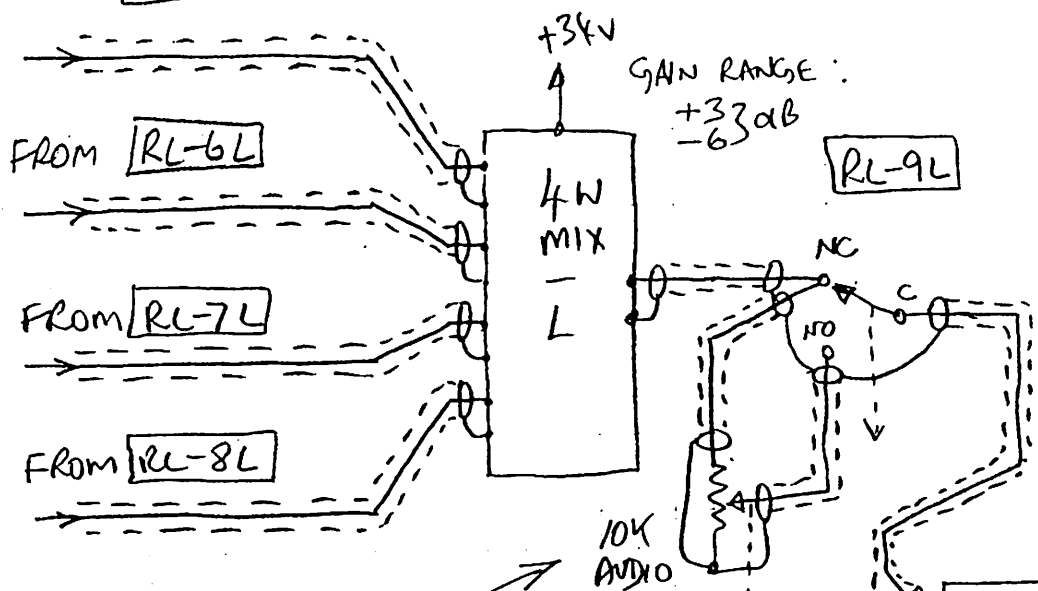

REMOTE FOOT VOLUME (L)  
PEDAL VIA MULTI-CORE  
SEE P(4)

ALL RELAYS:

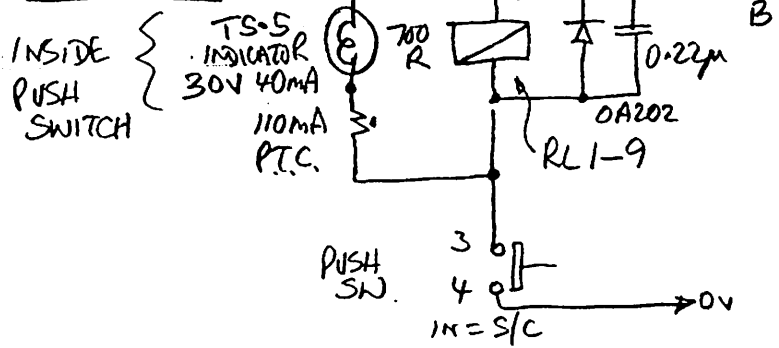

OUTPUTS-LEFT

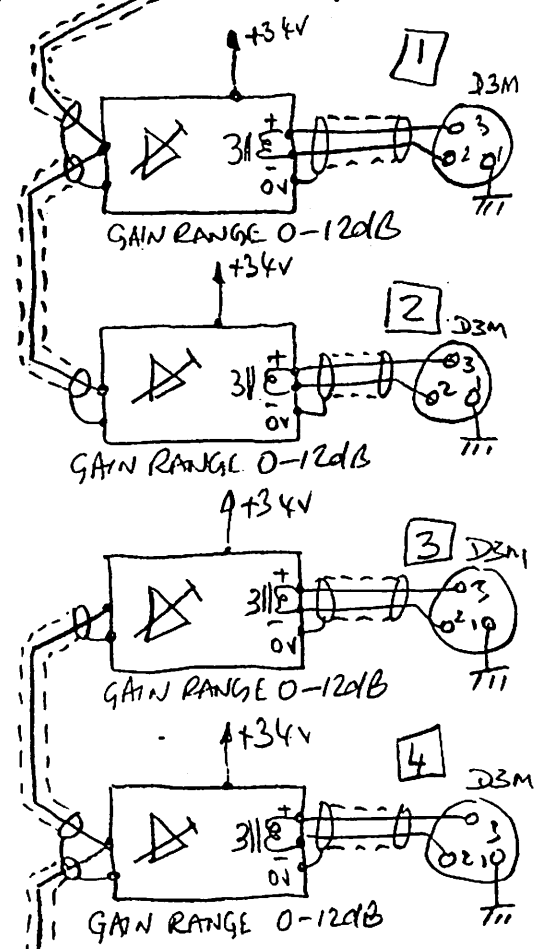

FROM RL-8R

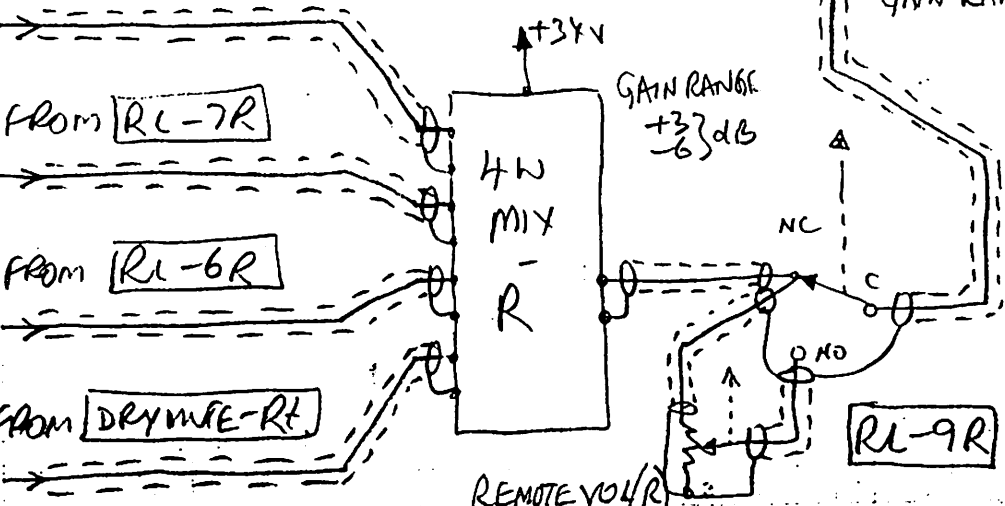

OUTPUTS-RIGHT



UNIT #2

OOPS

S/3/92  
S/N 232

8

POWER SUPPLIES

500mA T

POWER ON

MT1  
50VA

MT2  
20VA

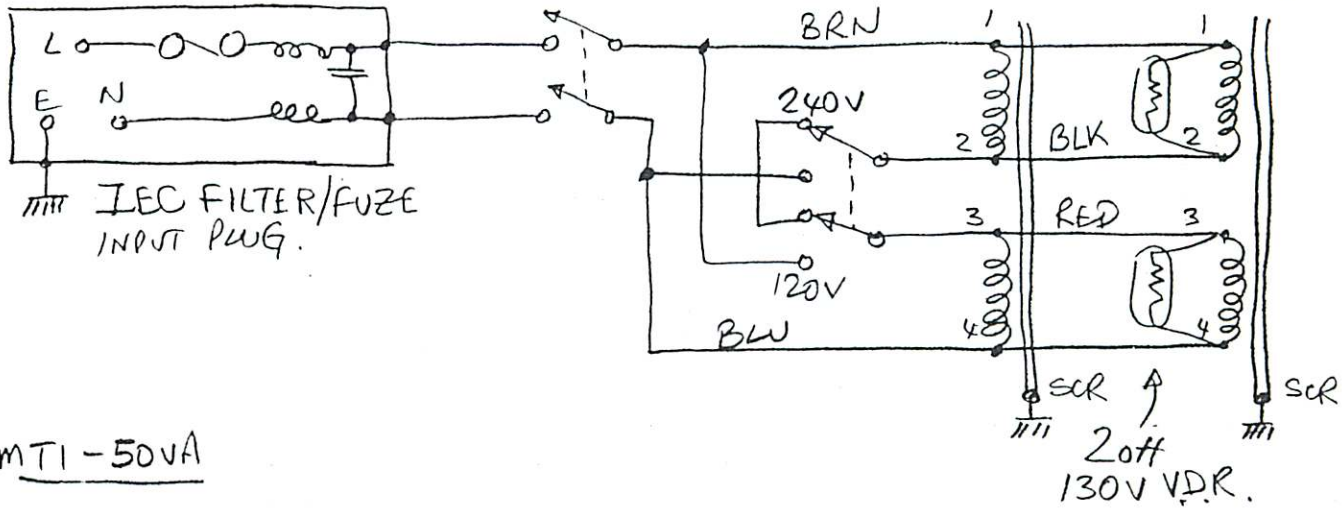

MT1 - 50VA

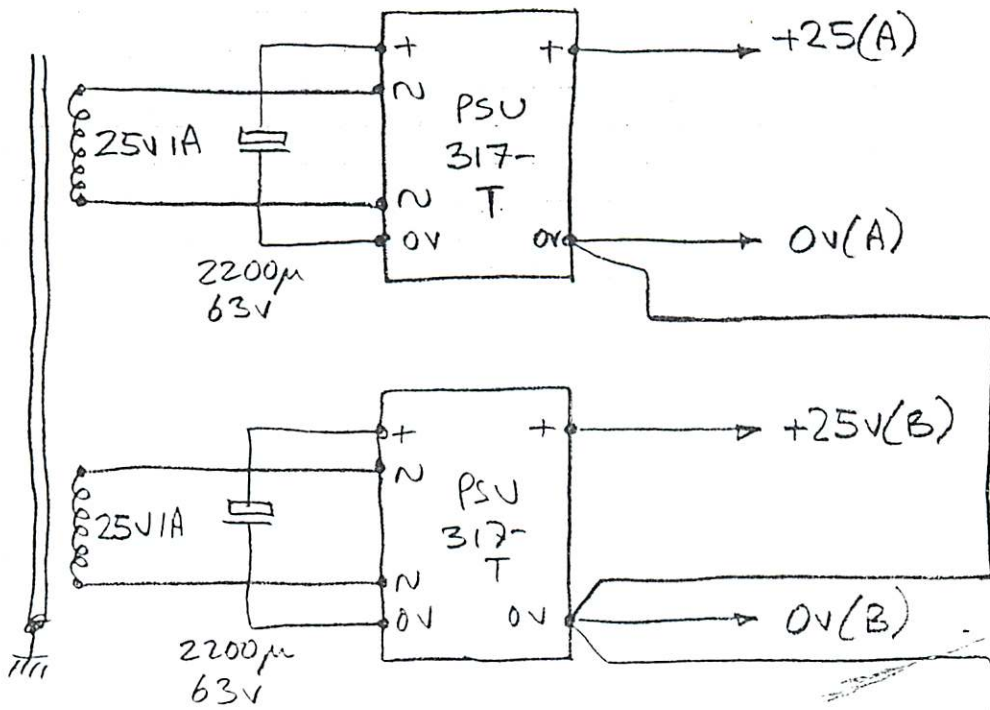

MT2 - 20VA

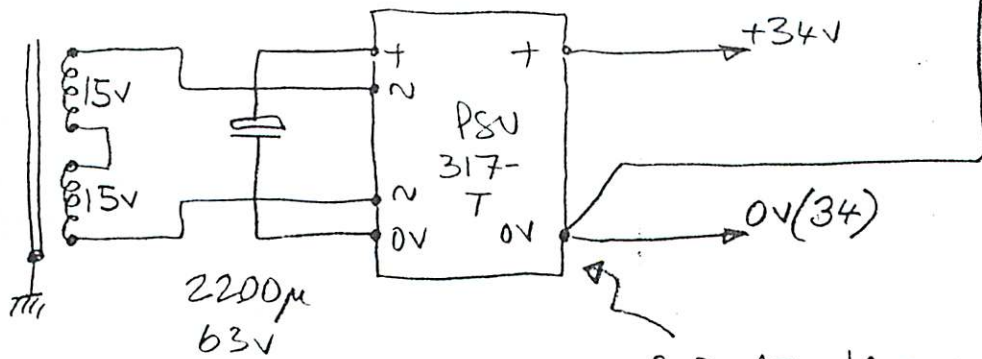

GROUND AT I/P ONLY.

# UNIT #2

# OO PPS

S/3/92  
S/N 232

(9)

## SEND/RETURN AND OUTPUT LEADS

A) INPUT FROM UNIT #1 (S/N 231)

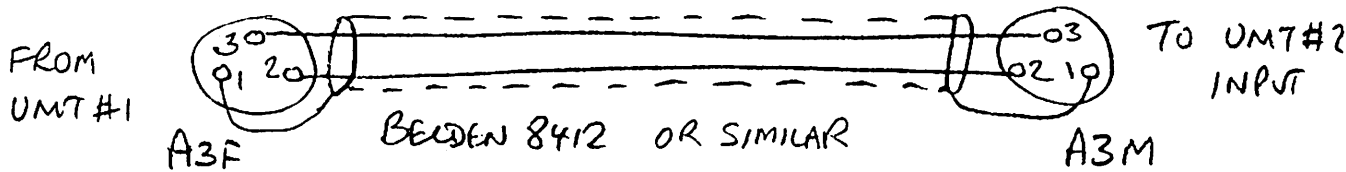

B) SENDS TO PRE-AMPS

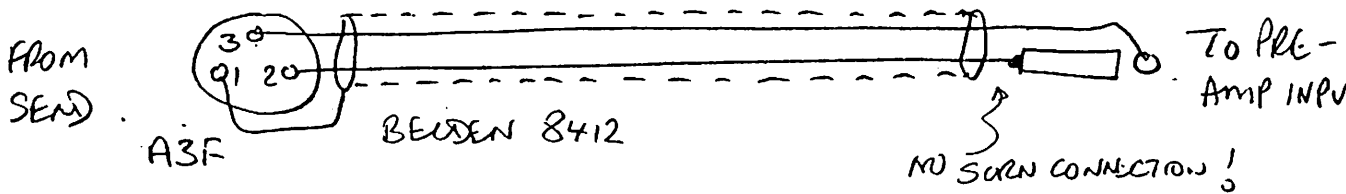

C) RETURNS FROM PRE-AMPS

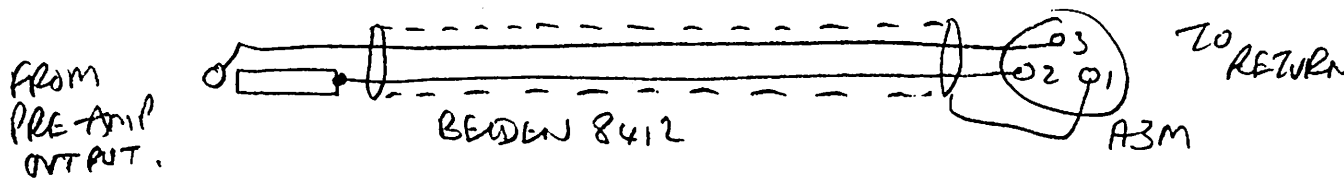

D) SENDS TO STEREO EFFECTS: IF JACK INPUTS USE LEADS AS IN (B) ABOVE.

IF XLR INPUT USE LEADS A3M/A3F AS IN (A) ABOVE.

E) RETURNS FROM STEREO EFFECTS: IF JACK OUTPUT USE LEADS AS IN (C) ABOVE

IF XLR OUTPUT USE LEADS A3M/A3F AS IN (A) ABOVE

F) OUTPUTS TO FEED UNIT #3 USE A3M/A3F AS IN (A) ABOVE.

TO FEED AMPS:- USE LEADS AS IN (B) ABOVE

NB SEND/RETURNS MAY BE USED FOR PEDALS (IN ADDITION TO THE S/R'S IN UNIT #1) USING THE LEADS AS IN (B) AND (C) ABOVE.