



---

**MX-80**  
**PROFESSIONAL RECORDER**  
OPERATION AND MAINTENANCE MANUAL

---



# **CAUTION**

To prevent fire or shock hazard :

Do not expose this appliance to rain or moisture.

Do not remove cover.

No user-serviceable parts inside.

Refer servicing to qualified service personnel.

PLEASE READ THROUGH SAFETY INSTRUCTIONS  
ON THE NEXT PAGE.

## SAFETY INSTRUCTIONS

1. Read Instructions - All the safety and operating instructions should be read before the appliance is operated.
2. Retain Instructions - The safety and operating instructions should be retained for future reference.
3. Heed Warnings - all warnings on the appliance and in the operating instructions should be adhered to.
4. Follow Instructions - All instructions should be followed.
5. Water and Moisture - The appliance should not be used near water - for example, near a bathtub, washbasin, kitchen sink, laundry tub, in a wet basement, or near a swimming pool, etc.
6. Carts and Stands - The appliance should be used only with a cart or stand that is recommended by the manufacturer.
7. Ventilation - The appliance should be situated so that its location or position does not interfere with its proper ventilation.  
For example, the appliance should not be situated on a bed, sofa, rug, or similar surface that may block the ventilation openings; or, placed in a built-in installation, such as a bookcase or cabinet that may impede the flow of air through the ventilation openings.
8. Heat - The appliance should be situated away from near sources such as radiators, heat registers, stoves, or other appliances (including amplifiers) that produce heat.
9. Power Sources - The appliance should be connected to a power supply only of the type described in the operating instructions or as marked on the appliance.
10. Grounding or Polarization - Precautions should be taken so that the grounding or polarization means of an appliance are not defeated.

11. Power-Cord Protection - Power-supply cords should be routed so that they are not likely to be walked on or pinched by items placed upon or against them, paying particular attention to cords at plugs. Convenience receptacles, and the point where they exit from the appliance.
12. Cleaning - The appliance should be cleaned only as recommended by the manufacturer.
13. Nonuse Periods - The power cord of the appliance should be unplugged from the outlet when left unused for a long period of time.
14. Object and Liquid Entry - Care should be taken so that objects do not fall into and liquids are not spilled into the enclosure through openings.
15. Damage Requiring Service - The appliance should be serviced by qualified service personnel when:
  - A. The power-supply cord or the plug has been damaged; or
  - B. Objects have fallen, or liquid has been spilled into the appliance; or
  - C. The appliance has been exposed to rain; or
  - D. The appliance does not appear to operate normally or exhibits marked change in performance; or
  - E. The appliance has been dropped, or the enclosure damaged.
16. Servicing - The user should not attempt to service the appliance beyond that described in the operating instructions.  
All other servicing should be referred to qualified service personnel.

# **WARNING**

This equipment generates, uses, and can radiate radio frequency energy and if not installed and used in accordance with the instructions manual, may cause interference to radio communications. It has been tested and found to comply with the limits for a Class A computing device pursuant to Subpart J of Part 15 of FCC Rules, which are designed to provide reasonable protection against such interference when operated in a commercial environment. Operation of this equipment in a residential area is likely to cause interference in which case the user at this own expense will be required to take whatever measures may be required to correct the interference.

## COMMUNICATION WITH OTARI FOR SERVICE INFORMATION AND PARTS

The OTARI PRODUCTS are manufactured under strict quality control and each unit is carefully tested and inspected prior to shipment from our factory.

If, however, some adjustments or technical support become necessary, replacement parts are required, or technical questions arise, please contact your nearest OTARI dealer or write to:

OTARI ELECTRIC CO., LTD.  
4-29-18, Minami Ogikubo,  
Suginami-ku, Tokyo, 167, Japan  
Phone: (03) 333-9631  
Telex: J26604 OTRDENKI  
Fax : (03) 331-5802

OTARI CORPORATION  
2 Davis Drive, Belmont,  
California 94002, U.S.A.  
Phone: (415) 592-8311  
Telex: 25 9103764890  
Fax : (415) 591-3377

OTARI ELECTRIC DEUTSCHLAND GmbH.  
Rudolf-Diesel-Str.12  
D-4005 Meerbusch 2 (Osterath)  
F.R. Germany  
Phone: 02159-50861 - 3  
Telex: 8531638 OTEL D  
Fax : 02159-1778

OTARI SINGAPORE PTE., LTD.  
625 Aljunied Road #07-05  
Aljunied Industrial Complex,  
Singapore 1438  
Phone: 743-7711  
Telex: 87 36935 RS36935 OTARI  
Fax : (743) 6430

OTARI ELECTRIC (UK) LTD.  
22 Church Street Slough Berkshire SL1 1PT  
United Kingdom  
Phone: SLOUGH (0753)822381  
Telex: 849453 OTARI G  
Fax : (0753) 823707

Another part of OTARI's continuous technical support program for our products, is the continuous revision of manuals as the equipment is improved or modified.

In order for you to receive our information and service applicable to your requirements, and for the technical support to function properly, please include the following information, most of which can be obtained from the name plate on the equipment in all correspondences.

1. Model Number
2. Serial Number
3. date of purchase
4. Name and address of dealer from whom machine was purchased
5. Power requirements (voltage and frequency) of the machine
6. Manual number to which you are referring

## TABLE OF CONTENTS

### SECTION 1: INTRODUCTION

|                                       |     |
|---------------------------------------|-----|
| 1.1 USING THIS MANUAL                 | 1-1 |
| 1.1.1 Organization                    | 1-2 |
| 1.1.2 Conventions within This Manual  | 1-3 |
| 1.2 OTARI MX-80 SERIES TAPE RECORDERS | 1-4 |

### SECTION 2: CONTROLS AND INDICATORS: A QUICK REFERENCE GUIDE

|   |      |
|---|------|
| 2.1 TRANSPORT CONTROLS AND INDICATORS                             | 2-1  |
| 2.2 VU METERS (UPPER FRONT PANEL)                                 | 2-10 |
| 2.3 AMPLIFIER CONTROLS (LOWER FRONT PANEL)                        | 2-11 |
| 2.3.1 Audio Control PCB   | 2-11 |
| 2.3.2 Serial Remote Control PCB                                   | 2-14 |
| 2.3.3 Audio Amplifier PCBs  | 2-15 |
| 2.4 POWER SUPPLY PANEL  | 2-18 |
| 2.5 INPUT AND OUTPUT CONNECTORS                                   | 2-18 |
| 2.6 REMOTE CONTROL UNIT - CB-124 (16 or 24CH) OR<br>CB-123 (32CH) | 2-20 |

### SECTION 3: OPERATION

|   |      |
|---|------|
| 3.1 MODES OF OPERATION  | 3-1  |
| 3.2 RECORDING WITH THE MX-80 - A TUTORIAL                       | 3-4  |
| 3.2.1 Threading the Tape on the Machine                         | 3-4  |
| 3.2.2 Recording the Basic Tracks                                | 3-6  |
| 3.2.3 Playing Back the Basic Tracks                             | 3-7  |
| 3.2.4 Recording Overdubs Using Sel-Rep Playback                 | 3-8  |
| 3.2.5 Recording Punch-In Overdubs                               | 3-8  |
| 3.2.6 Rehearsing the Punch-In                                   | 3-9  |
| 3.2.7 Bouncing or "Ping-Ponging" Tracks                         | 3-10 |
| 3.2.8 Using the Spot Erase Feature                              | 3-11 |
| 3.2.9 Playing Back the Tracks for Mixdown                       | 3-12 |
| 3.2.10 Library Winding the Tape                                 | 3-13 |
| 3.2.11 Moving the Tape by Hand for Editing                      | 3-13 |
| 3.2.12 Editing the Tape   | 3-13 |
| 3.2.13 Using the Variable Speed Feature                         | 3-14 |
| 3.2.14 Controlling the Capstan Speed with an External<br>Device | 3-15 |
| 3.2.15 Changing the Machine Speed Pairs                         | 3-15 |



SECTION 4: ALIGNMENT AND CALIBRATION

|          |  |      |
|----------|--|------|
| 4.1      | TRANSPORT ALIGNMENT  | 4-1  |
| 4.1.1    | Tools and Equipment Required   | 4-1  |
| 4.1.2    | Opening the Transport and Removing the Deck<br>Skin Panels           | 4-2  |
| 4.1.3    | Reel Tension Servo Adjustment  | 4-4  |
| 4.1.3.1  | Tension Arm Spring Tension Adjustment                                | 4-4  |
| 4.1.3.2  | Tachometer Quadrature/Phase Adjustment                               | 4-5  |
| 4.1.3.3  | Fast Wind Speed Reference Voltage Adjustment                         | 4-7  |
| 4.1.3.4  | Tension Sensor Position  | 4-8  |
| 4.1.3.5  | Tension Arm Sensor Gain Adjustment                                   | 4-10 |
| 4.1.3.6  | Play Acceleration Preliminary Adjustment                             | 4-10 |
| 4.1.3.7  | Fast Forward and Rewind Torque Adjustment                            | 4-11 |
| 4.1.3.8  | Reel Motor Torque Adjustment   | 4-11 |
| 4.1.3.9  | Tension Arm Position Adjustment                                      | 4-11 |
| 4.1.3.10 | Fast Wind and Spooling Wind Speed Adjustment                         | 4-12 |
| 4.1.3.11 | Tape Tension Check   | 4-13 |
| 4.1.3.12 | Capstan Servo Adjustment   | 4-13 |
| 4.1.4    | Capstan Servo Adjustment   | 4-13 |
| 4.1.4.1  | Preliminary Adjustment   | 4-13 |
| 4.1.4.2  | Phase Locked Loop Duty Cycle Adjustment                              | 4-15 |
| 4.1.4.3  | Gain Adjustment  | 4-15 |
| 4.1.4.4  | Capstan Servo Damping Adjustment                                     | 4-16 |
| 4.1.5    | Pinch Roller Timing  | 4-17 |
| 4.1.6    | Tape Lifter Adjustment   | 4-17 |
| 4.1.7    | Pinch Roller Position and Pressure Adjustment                        | 4-20 |
| 4.1.8    | Brake Adjustment   | 4-21 |
| 4.2      | ROUTINE AUDIO ALIGNMENT  | 4-23 |
| 4.2.1    | Tools, Materials, and Test Equipment Required                        | 4-23 |
| 4.2.2    | Demagnetizing the Heads and Tape Path                                | 4-23 |
| 4.2.3    | Cleaning the Tape Path   | 4-25 |
| 4.2.4    | Input Level, Output Level and Peak Indicator<br>Adjustment           | 4-26 |
| 4.2.5    | Reproduce Head Azimuth Alignment                                     | 4-27 |
| 4.2.6    | Record Head Azimuth Adjustment                                       | 4-28 |
| 4.2.7    | Reproduce Level Adjustment   | 4-29 |
| 4.2.8    | Low Speed Reproduce Equalization Alignment                           | 4-29 |
| 4.2.9    | High Speed Reproduce Equalization Alignment                          | 4-30 |
| 4.2.10   | Sel-Rep Level Adjustment   | 4-30 |
| 4.2.11   | Low Speed Sel-Rep Equalization Adjustment                            | 4-31 |
| 4.2.12   | High Speed Sel-Rep Equalization Alignment                            | 4-31 |
| 4.2.13   | Low Speed Record Bias, Equalization, and Record<br>Level Adjustment  | 4-32 |
| 4.2.14   | High Speed Record Bias, Equalization, and<br>Record Level Adjustment | 4-35 |
| 4.2.15   | Low Frequency Compensation Adjustment                                | 4-35 |
| 4.2.16   | Record Phase Compensation Adjustment                                 | 4-36 |
| 4.2.17   | Erase Bias Symmetry Adjustment                                       | 4-37 |
| 4.2.18   | Record Bias Symmetry Adjustment                                      | 4-38 |
| 4.2.19   | Gapless Punch-In/Punch-Out Test and Adjustment                       | 4-39 |



SECTION 5: OPTIONAL EQUIPMENT AND FIELD UPGRADES

|     |  |     |
|-----|--|-----|
| 5.1 | WIDE BAND MODIFICATION   | 5-1 |
| 5.2 | UPGRADING THE MX-80-24/32 FROM 24 TO 32 CHANNELS                 | 5-1 |
| 5.3 | INSTALLATION OF OVERBRIDGE CASE FOR DOLBY NOISE REDUCTION SYSTEM | 5-3 |

SECTION 6: INSTALLATION INSTRUCTIONS

|       |   |      |
|-------|---|------|
| 6.1   | UNCRATING THE MACHINE                           | 6-1  |
| 6.2   | INSPECTION                                      | 6-1  |
| 6.2.1 | Audio Control PCB                               | 6-1  |
| 6.2.2 | Audio Amplifier PCBs                            | 6-3  |
| 6.2.3 | Serial Remote Control PCB                       | 6-5  |
| 6.2.4 | Transport Control PCB                           | 6-6  |
| 6.2.5 | Power Supply Panel                              | 6-13 |
| 6.2.6 | Transport Assemblies                            | 6-14 |
| 6.2.7 | Remote Control Unit                             | 6-16 |
| 6.3   | HOOKING UP THE MX-80                            | 6-19 |
| 6.3.1 | Hooking Up the AC Power                         | 6-19 |
| 6.3.2 | Hooking Up the Audio Inputs and Outputs         | 6-19 |
| 6.3.3 | Hooking Up the Remote Control Unit (CB-123/124) | 6-22 |
| 6.3.4 | Using the Parallel I/O Connector                | 6-22 |
| 6.3.5 | Noise Reduction System Control                  | 6-26 |
| 6.3.6 | Serial I/O (Optional)                           | 6-28 |
| 6.4   | LEVEL MATCHING                                  | 6-30 |

SECTION 7: SPECIFICATIONS

|     |               |     |
|-----|---------------|-----|
| 7.1 | TAPE TRASPORT | 7-1 |
| 7.2 | ELECTRONICS   | 7-3 |
| 7.3 | PHYSICAL      | 7-4 |
| 7.4 | ACCESSORIES   | 7-4 |

SECTION 8: PARTS LISTS AND P.C.B. ASSEMBLIES

|     |             |     |
|-----|-------------|-----|
| 8.1 | GENERAL     | 8-1 |
| 8.2 | PARTS LISTS | 8-1 |

SECTION 9: EXPLODED VIEW DRAWINGS AND PARTS LISTS

|     |             |     |
|-----|-------------|-----|
| 9.1 | GENERAL     | 9-1 |
| 9.2 | PARTS LISTS | 9-1 |

SCHEMATIC DIAGRAMS

## LIST OF FIGURES

|             |  |      |
|-------------|--|------|
| Figure 1-1  | MX-80 Front Pannel   | 1-6  |
| Figure 1-2  | MX-80 Rear Pannel  | 1-7  |
| Figure 2-1  | Transport Control Pannel                                       | 2-2  |
| Figure 2-2  | Tape Transport   | 2-8  |
| Figure 2-3  | VU Meter Pannel  | 2-10 |
| Figure 2-4  | Audio Control PCB  | 2-12 |
| Figure 2-5  | Serial Remote Control PCB                                      | 2-15 |
| Figure 2-6  | Audio Amplifier PCB  | 2-16 |
| Figure 2-7  | Power Supply Pannel  | 2-18 |
| Figure 2-8  | Rear Pannel I/O Connectors                                     | 2-19 |
| Figure 2-9  | Remote Control Unit Control and Indicators                     | 2-21 |
| Figure 3-1  | Transport Features   | 3-1  |
| Figure 3-2  | Tape Threading   | 3-5  |
| Figure 4-1  | Location of Transport, Capstan, and Reel Control PCB           | 4-2  |
| Figure 4-2  | Deck Skin Panel Removal  | 4-3  |
| Figure 4-3  | Tension Arm Spring Tension Measurement                         | 4-5  |
| Figure 4-4  | Location of Trimmers and Check Points on Transport Control PCB | 4-6  |
| Figure 4-5  | Tach Waveforms   | 4-7  |
| Figure 4-6  | Location of Tacho I and Tacho II PCBs                          | 4-7  |
| Figure 4-7  | Location of Tension Sensor Adjustments                         | 4-8  |
| Figure 4-8  | Location of Trimmers and Check Points on Reel Control PCB      | 4-9  |
| Figure 4-9  | Tension Sensor Voltage Adjustment                              | 4-10 |
| Figure 4-10 | Tension Arm Postion Adjustment                                 | 4-12 |
| Figure 4-11 | Location of Trimmers and Test Points on Capstan Control PCB    | 4-14 |
| Figure 4-12 | Capstan Waveforms  | 4-15 |
| Figure 4-13 | Opening the Transport  | 4-18 |
| Figure 4-14 | Tape Lifter Adjustments  | 4-19 |
| Figure 4-15 | Pinch Roller Pressure Measurement                              | 4-20 |
| Figure 4-16 | Brake Adjustments  | 4-21 |
| Figure 4-17 | Record and Reproduce Azimuth Adjustment Screws                 | 4-27 |
| Figure 4-18 | Record Phase Compensation Waveform                             | 4-36 |
| Figure 5-1a | Upgrade Modification   | 5-4  |
| Figure 5-1b | Upgrade Modification   | 5-5  |
| Figure 5-2  | Overbridge Case Assembling                                     | 5-7  |

|             |  |      |
|-------------|--|------|
| Figure 6-1  | Location of Switchs on Audio Control PCB             | 6-2  |
| Figure 6-2  | Audio Amplifier PCB                                  | 6-4  |
| Figure 6-3  | Serial Remote Control PCB                            | 6-5  |
| Figure 6-4  | Screws to Remove for Access to Transport Control PCB | 6-7  |
| Figure 6-5  | Inside View of Rear MX-80                            | 6-7  |
| Figure 6-6  | transport Control PCB                                | 6-9  |
| Figure 6-7  | Location of Transport Assemblies                     | 6-15 |
| Figure 6-8  | AC Power Connector                                   | 6-16 |
| Figure 6-9  | Balanced Input and Output Connector Wiring           | 6-17 |
| Figure 6-10 | Unbalanced Input and Output connector Wiring         | 6-18 |

## LIST OF TABLES

|           |  |      |
|-----------|--|------|
| Table 2-1 | Bias Setting                                     | 2-11 |
| Table 2-2 | Monitor Mode Indicators                          | 2-29 |
| Table 2-3 | Record Indicator and Modes                       | 2-30 |
| Table 4-1 | Recommended Record Bias Setting                  | 4-34 |
| Table 6-1 | Switch on the Tranxport Control PCB              | 6-10 |
| Table 6-2 | Switches and Jumpers on the CPU PCA (PB-4FGA)    | 6-16 |
| Table 6-3 | AMP Remote Control Unit Error Message            | 6-18 |
| Table 6-4 | Remote Control Connctor Pin Assignments          | 6-22 |
| Table 6-5 | Parallel I/O Connector Pin Assignments           | 6-23 |
| Table 6-6 | Noise Reduction Control connector Pin Asignments | 6-27 |
| Table 6-5 | Serial I/O Connector Pin Assignments             | 6-28 |

## SECTION 1: INTRODUCTION

The OTARI MX-80 Series machines are extremely versatile, high performance 16, 24 or 32 track recorder/reproducers using 2" wide tape and 10-1/2" NAB reels. The MX-80 Series consists of eight machines, each having a different combination of tape speed pairs (7-1/2 and 15 ips or 15 and 30 ips) and track configurations (16 tracks, 24 tracks, 24 tracks pre-wired for 32 tracks, or 32 tracks). Table 1-1 describes the various configurations and model numbers.

Table 1-1 MX-80 Series Configurations

| Type  | Tape Width | Tape Speed         | Catalog Number | Note                       |
|-------|------------|--------------------|----------------|----------------------------|
| MX-80 | 2"         | 30ips/<br>15ips    | MX-80-16-H     | 24ch pre-wired<br>for 32ch |
|       |            |                    | MX-80-24-H     |                            |
|       |            |                    | MX-80-24/32-H  |                            |
|       |            |                    | MX-80-32-H     |                            |
|       |            | 15ips/<br>7-1/2ips | MX-80-16-L     | 24ch pre-wired<br>for 32ch |
|       |            |                    | MX-80-24-L     |                            |
|       |            |                    | MX-80-24/32-L  |                            |
|       |            |                    | MX-80-32-L     |                            |

1.1 USING THIS MANUAL

This manual is intended for use with any of the models and configurations listed above. The descriptions and references refer to the MX-80-24-H model (the 24 track, high speed-pair version). If any differences exist between the referenced machine and another model, those differences will be explained fully.



## Section 1

### 1.1.1 Organization

This manual is divided into eleven sections beginning with this INTRODUCTION which contains general information about the machine and about the manual.

The second section is the REFERENCE GUIDE which contains a keyed guide to the controls and indicators. This REFERENCE GUIDE provides detailed information about each control and its functions. You should use this section of the manual when you have a question about the function of a particular control or indicator.

Third is the OPERATIONS section which describes the operation of the machine. This section is divided into two parts, first, a list of all the operating modes of the machine, and second, "Recording with the MX-80", a tutorial organized by task, starting with threading tape on the machine and recording basic tracks, and continuing through overdubs, punch-ins, etc. You should use this section when you wish to learn "how to" perform a task or operation (like spot erase or spooling).

The fourth section of this manual covers ALIGNMENT AND CALIBRATION including the information needed to perform the routine alignments and calibrations associated with normal operation of the machine (like head azimuth, bias adjustment, or output level adjustment). You should refer to this section of the manual when you are performing the normal maintenance and calibration routines that must be done to keep the recorder operating at peak performance.

The fifth section of this manual is reserved for OPTIONAL EQUIPMENT AND FIELD UPGRADES that are available for use with the MX-80 series tape recorders. Included in this section are instructions for converting a 24 track version of the MX-80 to a 32 track version. You should place update information in this section as you received it during your ownership of the MX-80.

Section six, INSTALLATION, contains the information required when uncrating and installing the MX-80 for the first time, or when interfacing the machine to the recording mixer or other equipment.

The seventh section of the manual lists the SPECIFICATIONS of the MX-80 Series.

Section eight contains PRINTED CIRCUIT BOARD LAYOUTS, with two-color "x-ray" views of each printed circuit board showing the component locations and foil traces.

Section nine, EXPLODED VIEWS AND PARTS LISTS, contains assembly drawings of the machine "exploded" to show internal parts and hardware, and the order of assembly. Each exploded view is keyed to an accompanying parts list showing OTARI part numbers for all mechanical components.

The final section of the manual contains the SCHEMATICS for all electronics and printed circuit boards.

### 1.1.2 Conventions within This Manual

The use of terms channel and track may require some clarification. This manual refers to the signal, or the path of the signal, recorded on the tape as a TRACK, and the electronics or controls for that path are referred to as a CHANNEL.

Generally, this manual uses all upper case type to describe a switch or control when that item is similarly labeled on the machine (e.g., the PLAY button). Where a switch or button is not labeled, or the reference is less clear, only the first letter of the item is capitalized (e.g., the Cue lever near the CUE button). Machine status or operating modes are described with an upper case first letter (e.g., you press the PLAY button to place the machine in Play mode). Normal parentheses ( ) are used for examples and parenthetical comments. Square brackets [ ] are used for reference to callouts in certain illustrations. The square brackets in a particular sub-section are either all referenced to the same figure, as noted in that sub-section, or are individually referenced (e.g., [Fig. 2-1,3], meaning callout "3" in Figure 2-1).

The information and procedure in Section 6, INSTALLATION should be followed very carefully when the machine is first uncrated and installed. Performing the inspection steps will familiarize you with the machine and its component parts if this is your first contact with the MX-80 series of tape recorders.

Please read Sections 2 and 3 carefully before using the machine. In the future, after you are more familiar with the machine, if you need information about a specific operation, or instructions on how to perform a particular function, refer to the Tutorial instructions in Section 3.



## Section 1

### 1.2 OTARI MX-80 SERIES TAPE RECORDERS

The MX-80 Series tape transport is fully microprocessor controlled to provide precision tape handling characteristics while maintaining the high degree of reliability long associated with the OTARI line of professional tape recorders. The transport controls (PLAY, F.FWD, REWIND, STOP, CUE, EDIT/UNLOAD, etc.) direct commands to the microprocessor which, in turn, controls the activities of the Capstan and Reel Servo circuits to provide the desired operating mode or function. The microprocessor provides two-level illumination for the transport control buttons, dim when "off", flashing when "ready" to perform a function, and bright when "active" after a function has been selected, giving confirmation of the operating mode to the operator.

The plug-in multi-track head assembly allows replacement of a head assembly without having to perform time-consuming height, wrap, and zenith adjustments. Only the azimuth adjustment need be verified whenever changing heads, or optimizing the alignment for a tape recorded on another tape recorder. The head assembly is equipped with a scrape flutter roller located between the record and reproduce head stacks. A head shield, which is manually moved up and down, is provided in front of the head stacks. The head shield rises automatically in the Play and Record modes.

The capstan shaft is driven directly by a DC servo motor which is controlled by a quartz crystal-based phase-locked-loop servo system. A switch on the transport selects between the two operating speeds (7-1/2, 15 ips or 15, 30 ips). The Speed Mode Switch on the Remote Control Unit (CB-123, CB-124) selects between the three available Speed modes; FIX - crystal controlled speed selected by the Speed switch on the transport, VARI - variable speed  $\pm 50\%$ , and EXT - variable speed controlled by an external speed reference signal (9,600 Hz nominal).

Constant tape tension is provided by the reel motor servo circuit. The tape tension arms utilize non-contact photo-optical sensors to generate feedback signals for the Reel Control Printed Circuit Board (PCB). Constant tension is applied to the tape in all but Edit/Unload mode to insure fast, accurate, stress free tape handling. Motion sensing and accurate tape speed information are provided by the Tachometer Roller to the transport control circuits in the form of tach pulses. These tach pulses are also used to control the Fast Forward and Rewind speeds, and to provide tape length information to the direct-reading Tape Timer.

Located in the pedestal portion of the MX-80, the Audio section contains the Audio Control PCB, the Serial Remote Control PCB, the Audio Amplifier PCBs (16, 24 or 32), and the Power supplies for ;the various sections of the tape recorder. The Audio Control PCB contains the Test Signal jack (for application of a test signal to all channels simultaneously), a selector switch for High or Low Reference Flux density and indicators showing the level selected, the Bias switch which allows bias setting for two different tape formulations, EQ switch for selecting IEC or NAB equalizer, high/low select switch for output and input level, gapless function on/off switch, Dolby HX PRO\* on/off switch and VU meter sensitivity selector switch.

The Serial Amplifier Remote Control PCB contains two on/off switches for the selection of Stop Standby and Fast Standby modes (Refer to Section 4.1).

The Audio Amplifier PCBs each contain the Record, Reproduce, Sel-Rep, and Bias electronics for one audio channel. Front panel adjustments are provided for Record and Reproduce Equalization at both currently selected speeds, Record, Reproduce and Sel-Rep gain, Record Phase Compensation and Repro Low Frequency Compensation for each speed of the current speed pair, and individual channel Bias adjustment. Each channel is provided with an individual LINE OUTPUT Jack on the front panel, for test purposes, in addition to the XL type OUTPUT connector provided on the rear of the machine.

A VU meter is provided for each channel. In each VU meter are two LED indicators, one to indicate signal level peaks that are too short to cause the VU meter to indicate accurately, and another to indicate the channel's Record status.

Each MX-80 Series tape recorder includes either the CB-124 (16 or 24 tracks) or the CB-123 (32 tracks) full function Remote Control Unit.

The Remote Control Unit provides control of monitor (Input/Sel-Rep/Repro) and Record Ready switching and indication; transport mode, Search-Cue, Search-Zero, Repeat, and Speed Control functions.

The Remote Control Unit also features four Channel Status memories to store and recall the mode status (Ready/Safe, Mute/Input/Sel-Rep/Repro) of all the Channels simultaneously.

---

\* HX PRO headroom extension originated by Bang and Olufsen and manufactured under license from Dolby Laboratories Licensing Corporation. "Dolby", the Double-D symbol and HX PRO are trademarks of Dolby Laboratories Licensing Corporation.



Section 1

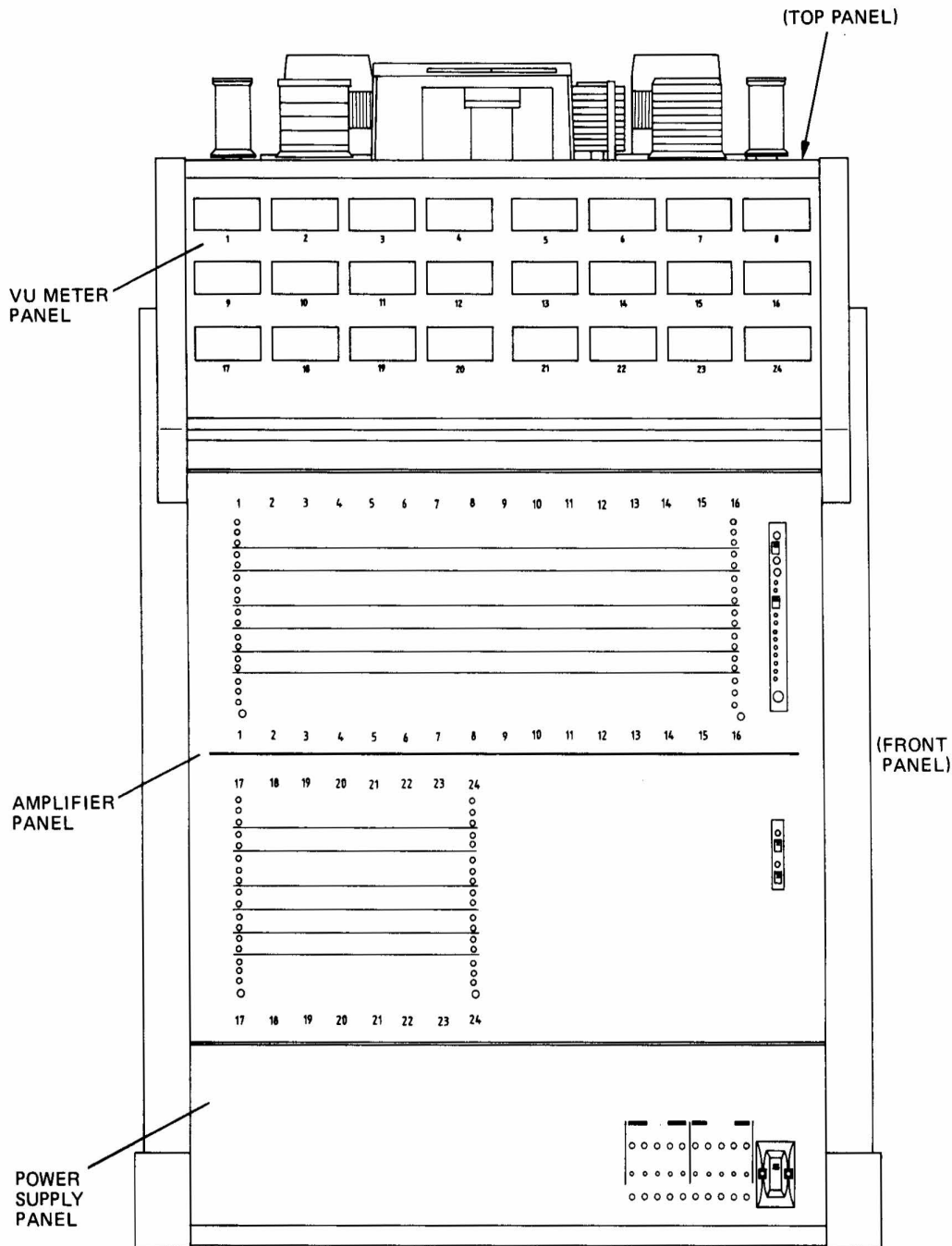

Figure 1-1 MX-80 Front Panel

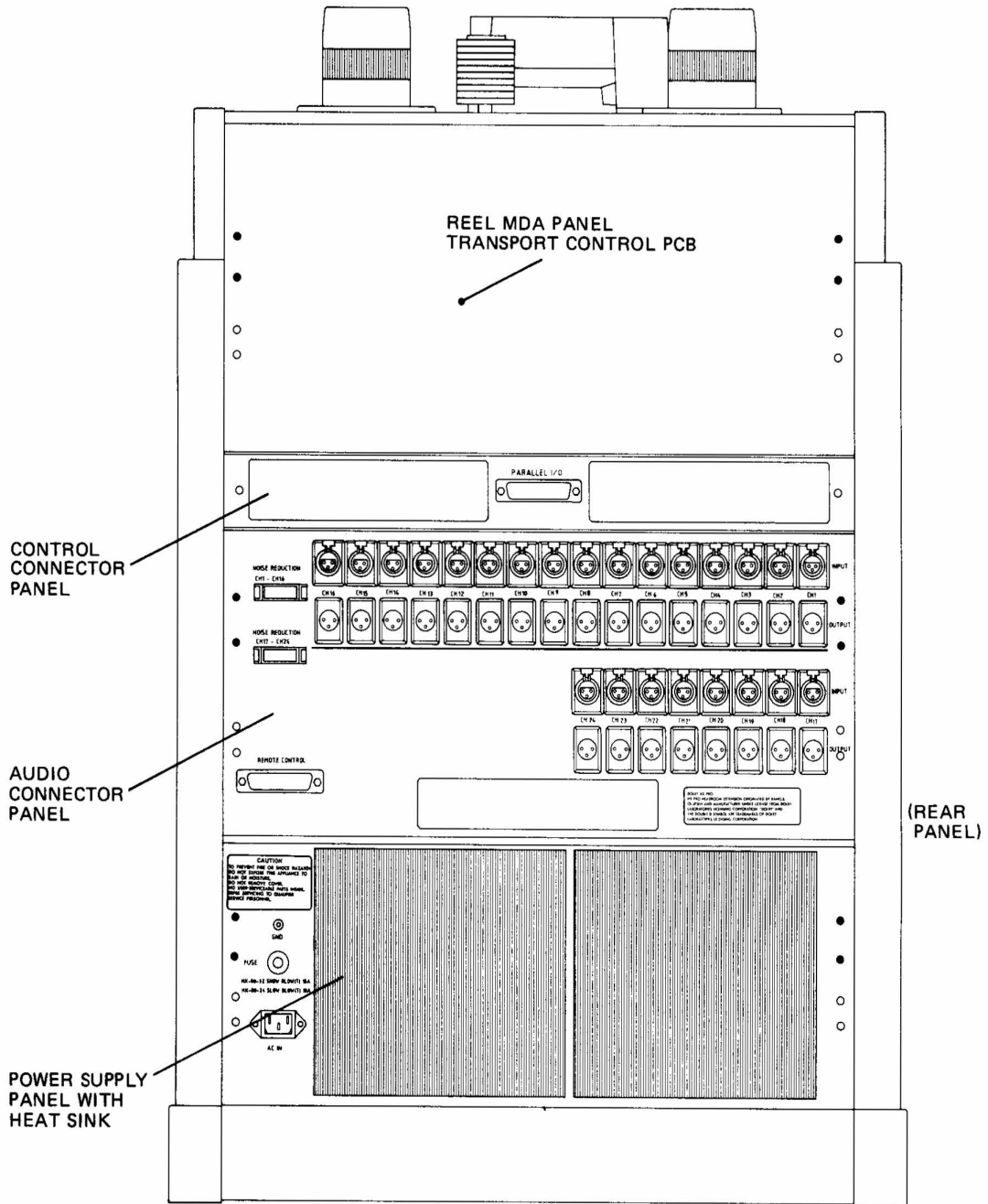

Figure 1-2 MX-80 Rear Panel

SECTION 2:  
CONTROLS AND INDICATORS: A Quick Reference Guide

NOTE: Numbers in brackets refer to the callouts in each figure of this section.

2.1 TRANSPORT CONTROLS AND INDICATORS

[1] F.FWD button

Pressing this button places the transport in Fast Forward wind mode. The button will be brightly illuminated (white).

Keeping the F.FWD button pressed, and then pressing the 2nd FUNCTION button places the transport in Forward Spooling mode for winding tape onto the take-up reel with a smoother tape pack than is achieved at full wind speed.

[2] REWIND button

Pressing this button places the transport in Rewind mode. The button will be brightly illuminated (white).

Keeping the REWIND button pressed, and then pressing the 2nd FUNCTION button places the transport in Reverse Spooling mode for winding tape onto the supply reel with a smoother tape pack than is achieved at full wind speed.

[3] STOP button

Pressing the STOP button when the transport is in Play, Reverse Play, F.Fwd, Rewind, Edit Play or Spooling mode, causes the tape motion to stop. The button will be brightly illuminated (blue).

Pressing this button when the transport is in Unload mode and the STOP button is flashing, (such as when tape has just been threaded, and the slack has been removed by turning the reels by hand) causes the transport to apply tension to the tape in preparation for other transport modes. The button will become brightly illuminated (blue).

Pressing the 2nd FUNCTION button simultaneously with the STOP button causes the capstan motor to reverse direction in preparation for Reverse Play mode.

Section 2

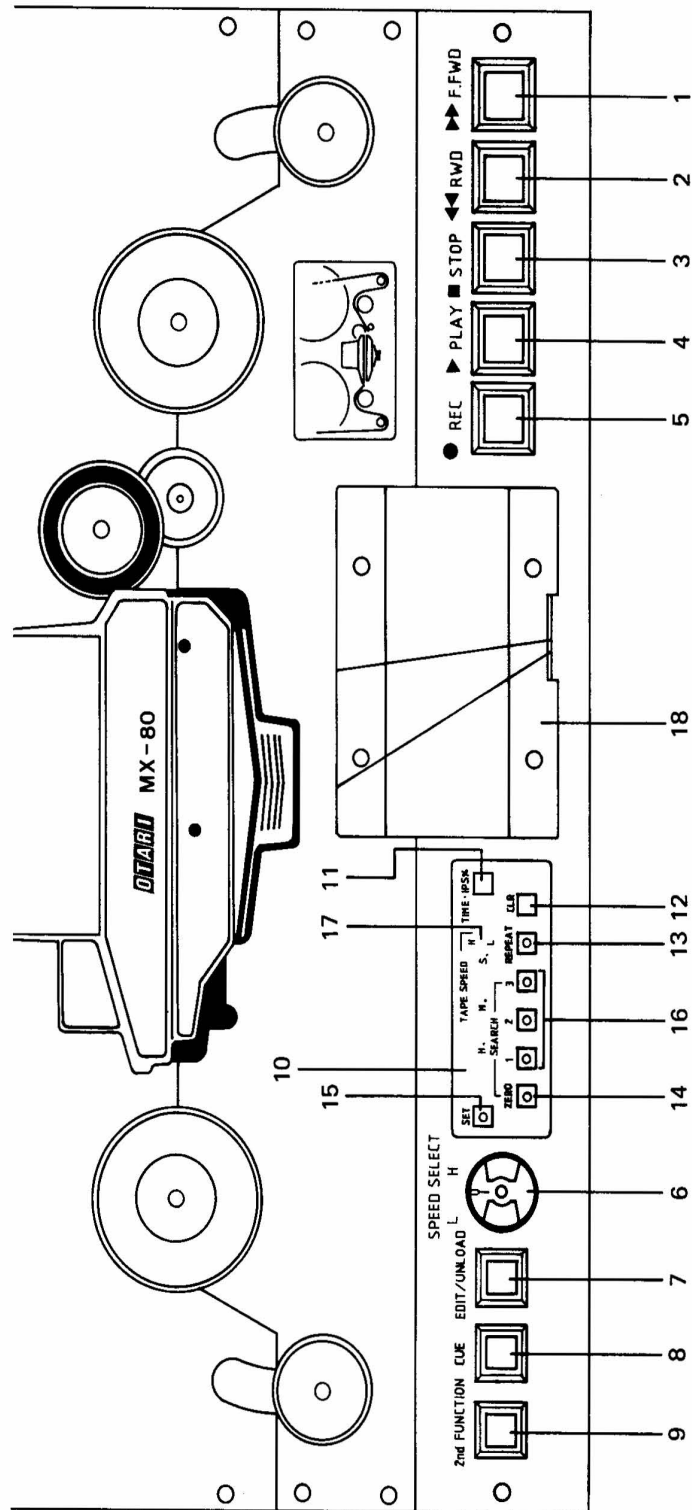

Figure 2-1 Transport Control Panel

NOTE: There is a slight delay while the capstan motor achieves crystal-locked speed, when reversing.

[4] PLAY button

Pressing this button places the transport in Play mode, causing tape to wind onto the take-up reel at the selected speed (H or L). The button will become brightly illuminated (white).

Pressing the PLAY button while in F.Fwd or Rewind mode causes the tape to decelerate and then enter the Play mode.

Pressing this button while the transport is in Edit Ready mode (with the EDIT/UNLOAD button flashing) causes the transport to enter Dump Edit mode.

Pressing this button while the transport is in Search Cue or Search Zero mode causes PLAY button to flash and the transport to enter Play mode upon reaching the end of the Search.

Pressing the PLAY and 2nd FUNCTION buttons simultaneously causes the machine to enter Reverse Play mode.

[5] RECORD button

When a channel is in Record Ready mode the RECORD button will flash (red). You may select one of two methods of entering Record mode. The two methods are:

1. Pressing this button simultaneously with the PLAY button. The button will be brightly illuminated (red).
2. Pressing the RECORD button while the transport is in Play mode (also known as Punch-In). The button will be brightly illuminated (red).

The MX-80 is factory preset for method 2.

Similarly, you may select between two methods of exiting from Record mode:

1. Keeping the RECORD button pressed and pressing the STOP button (Punch-Out).
2. Pressing the PLAY button while in Record mode.

The MX-80 is factory preset for method 2.



## Section 2

The selection of Punch-In and Punch-Out methods is made via switches DSW3-1 and DSW3-2 on the Transport Control PCB.

Pressing this button simultaneously with 2nd FUNCTION button causes the transport to enter Spot Erase mode. Pressing the RECORD button again, and holding it, while slowly moving the tape by hand, causes the erase circuitry to be activated to erase the tape at the Erase Head. Releasing the RECORD button will deactivate the Erase signal.

Pressing this button while the transport is in Reverse Play mode causes the MX-80 to enter Reverse Erase mode.

### [6] SPEED SELECT switch and TAPE SPEED indicator

This switch selects between the High or Low speed of the speed pair selected internally. On high speed-pair machines the H setting is 30 ips and the L setting is 15 ips. On low speed-pair machines the H setting is 15 ips and the L setting is 7-1/2 ips.

### [7] EDIT/UNLOAD button

Pressing this button while the transport is in Stop mode causes the transport to enter Edit Ready mode and the button will flash (white). Pressing the EDIT/UNLOAD button again causes the transport to enter Unload mode and remove the tension from the tape.

Pressing this button when the transport is in Play mode causes the machine to enter Edit Play mode (Dump Edit) in which the Take-up reel motor stops, allowing tape to "dump" over the side of the machine. In Edit Play (Dump Edit) mode the button will be brightly illuminated (white).

### [8] CUE button

Holding the CUE button pressed causes the tape lifters to remain retracted only as long as the button is held pressed. Tapping the CUE button causes the tape lifters to remain retracted until the next time the CUE button is pressed. When the lifters are retracted, the audio output is attenuated and the high frequencies rolled-off to prevent damage to the monitor speakers.

When the CUE button is pressed, and the lifters are not retracted, the audio is unmuted and is not attenuated, allowing you to listen for slate or marker tones without winding the tape across the heads. Press the CUE, STOP, or PLAY button to leave Cue mode.

Pressing this button while in Stop mode causes the machine to enter Stop Cue mode.

Pressing either the F.FWD or REWIND button while in Stop Cue mode allows the audio to be monitored and the tape to be wound in the direction indicated. Depending upon the setting of DSW3-3 on the Transport Control PCB, the lifters will remain retracted, and the audio attenuated, as described above, or the lifters will not retract, and the audio is unmuted and not attenuated.

[9] 2nd FUNCTION button

Pressing the 2nd FUNCTION button with other buttons provides access to additional functions, such as Reverse Play, which are not labeled on the machine. Each function is described with the appropriate button.

[10] Tape Timer display (H.M.S.)

The Tape Timer displays the current tape time in Hour, Minute, Second format. If the tape is located behind the 0.00.00 position the Tape Timer will display the time as negative (or -) time, relative to 0.00.00. If the SPEED SELECT switch is changed, the Tape Timer automatically recalculates the time displayed to be correct for the new speed.

The Tape Timer display is also utilized to display any error messages resulting from the Power-On self-test.

[11] TIME-IPS-% button

Pressing this button causes the Tape Timer display to show the Tape Time, the selected Play Speed in ips, or the Percentage of Play Speed, in turn.

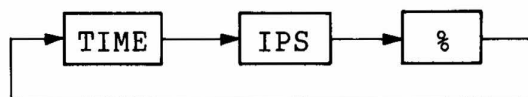

[12] CLR button

Pressing this button simultaneously with another button clears the selected function as follows:

## Section 2

CLR + SET ..... SET mode is canceled.

CLR + TIME-IPS-% .... The tape Timer display is cleared to 0.00.00.

CLR + SEARCH 1 - 3 .. The stored cue point is cleared

### [13] REPEAT button

Pressing the REPEAT button, and then pressing any two illuminated Cue buttons (ZERO, 1, 2, 3), causes the machine to enter Repeat mode. Then pressing the PLAY button, causes the machine to play from the first location to the second, Rewind to the first location and Play again, repeating until Repeat mode is deactivated.

### [14] SEARCH ZERO button

Pressing this button causes the transport to F. Forward or Rewind the tape, stopping when the tape timer reads 0.00.00.

Pressing the PLAY button while in Search Zero mode causes the PLAY button to flash and when the tape reaches 0.00.00, the transport enters Play mode.

Pressing the STOP, F.FWD, or REWIND button while in Search Zero mode causes the machine to leave Search Zero mode and take the action directed by the button.

### [15] SET button

Pressing this button causes the MX-80 to enter Set mode, which is indicated by the flashing of the display's decimal points. Set mode allows the tape times for three cue points to be entered in the following manner:

|              |       |                        |
|--------------|-------|------------------------|
| SEARCH ZERO  | ..... | + or - sign            |
| SEARCH CUE 1 | ..... | Hours digit            |
| SEARCH CUE 2 | ..... | Tens of Minutes digit  |
| SEARCH CUE 3 | ..... | Units of Minutes digit |
| REPEAT       | ..... | Tens of Seconds digit  |
| CLR          | ..... | Units of Seconds digit |

The selected digit will increment each time the corresponding button is pressed.



To store the tape time which has been entered onto the display in Set mode as a cue point, press and hold the SET button, and then press the desired SEARCH CUE button.

Simultaneously press the CLR and SET buttons for clearing the Set mode.

[16] SEARCH 1, 2, 3 buttons

If a button is not illuminated, there is no tape location stored for that Cue Point. Pressing an unlit SEARCH 1, 2, 3 button causes the current time shown on the Tape Timer display to be stored as that Cue Point, and that button to become illuminated.

If a SEARCH 1, 2, 3 button is illuminated, a tape location has been stored for that Cue Point. Pressing that button causes the transport to search to the location stored as that Cue Point. The location will be displayed on the Tape Timer display for approximately 2 seconds at the beginning of the search.

Pressing the PLAY button while in Search mode causes the PLAY button to flash, and when the tape reaches the location being searched to, the transport will enter Play mode.

Pressing the STOP button together with any SEARCH 1,2,3 button causes the Tape Timer display to show the location stored for that button.

Pressing the CLR button simultaneously with any SEARCH 1, 2 or 3 button causes the location stored for that cue point to be cleaned.

NOTE: There are different SEARCH 1,2,3 buttons on the Remote Control Unit which store the different Cue Points from those on Transport Control Panel. Another words, all together 6 Cue Points can be stored with the MX-80.

[17] TAPE SPEED(H/L) Indicator

This LED indicates the position of the SPEED SELECT switch.

Section 2

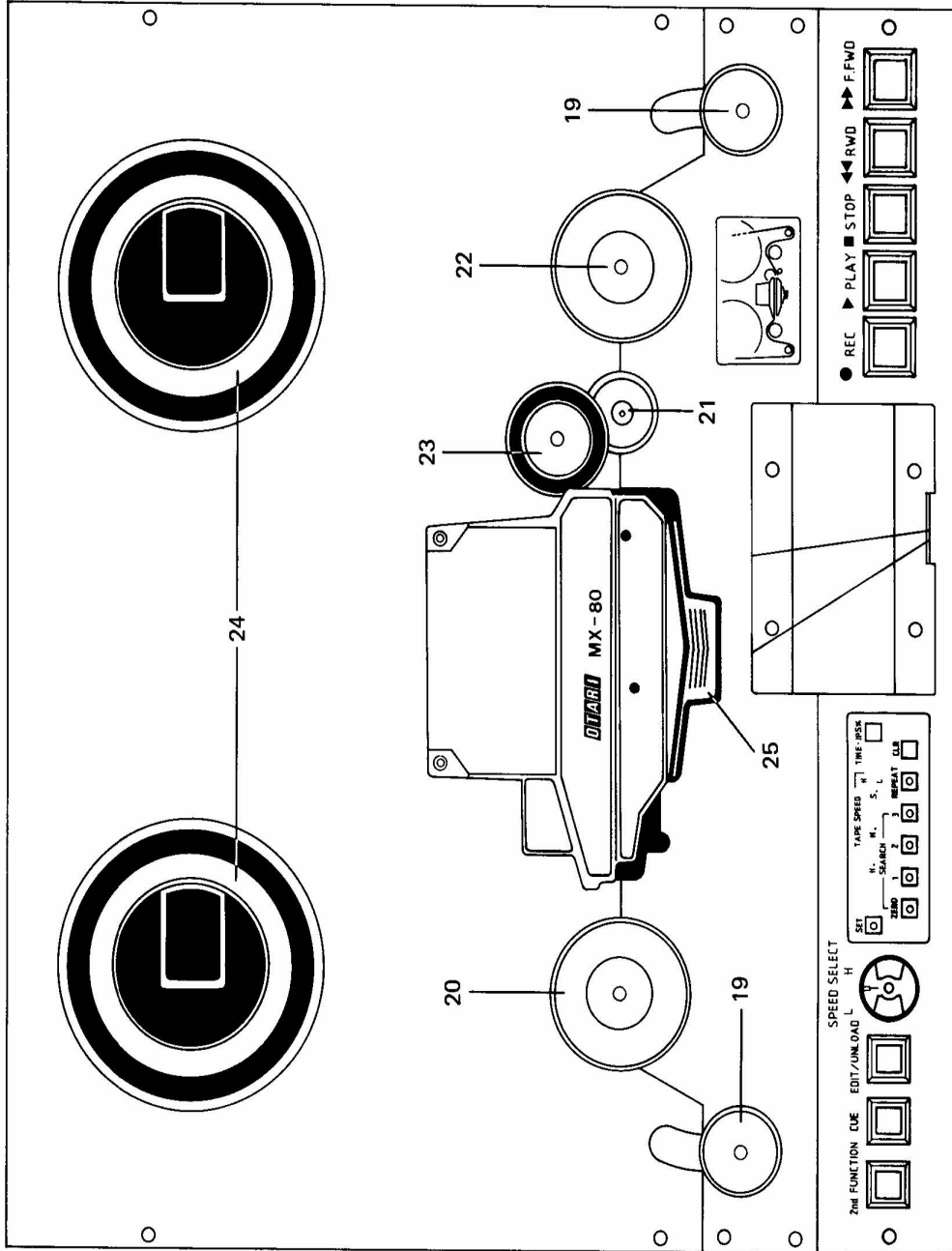

Figure 2-2 Tape Transport

[18] Tape Splicing Block

This conveniently located splicing block has been provided to make tape editing easier. Lay the magnetic tape in the slot and cut it using the groove to guide your blade.

[19] Tape Tension Arms

These swing arms are connected to the sensor mechanisms that provide tension feedback information to the capstan and reel control circuits. The arms also activate the safety switches which stop all transport functions if too much slack develops in the tape path or if the tape becomes unthreaded from the reel. After threading the tape, the take-up and supply reels should be turned by hand to remove the slack in the tape path, and to move the tape tension arms away from the bottom of their travel.

[20] Guide Roller

This rotating tape guide provides tape guidance during fast wind modes, and acts as an impedance roller during Play and Record modes to help damp out any fluctuations in tape speed caused by irregularities in the supply reel tape pack.

[21] Capstan Shaft

The capstan shaft is driven by a DC servo motor which is controlled by a quartz crystal reference in a phase-locked-loop circuit located on the Capstan Control PCB.

[22] Tachometer Roller

Tape motion across this roller causes it to rotate, generating tach pulses for accurate measurement of the tape length and speed by the microprocessor and tape timer circuits. In Stop mode you can move the tape for editing by turning the top of the tachometer roller by hand. The tape will follow the motion of the roller.

NOTE: Do not "jerk" the Tachometer Roller when moving tape by hand or the tape may slip against the roller.

[23] Pinch Roller

The tape is driven in Play, Reverse Play, Record, and Dump Edit modes by the rotation of the Capstan shaft against the Pinch Roller.

Section 2

[24] Reel tables

Reel tables with quick-release levers and locating pins.

[25] Head Shield

The Head Shield is manually retracted by pushing it down until it latches. When the Head Shield is in the retracted position, pressing it down causes the latch to be released and the shield will rise into position. The Head Shield will automatically rise, if retracted, whenever the MX-80 enters Record or Play mode if SW4-3 on the Transport Control PCB is in the On position.

2.2 VU METERS (UPPER FRONT PANEL)

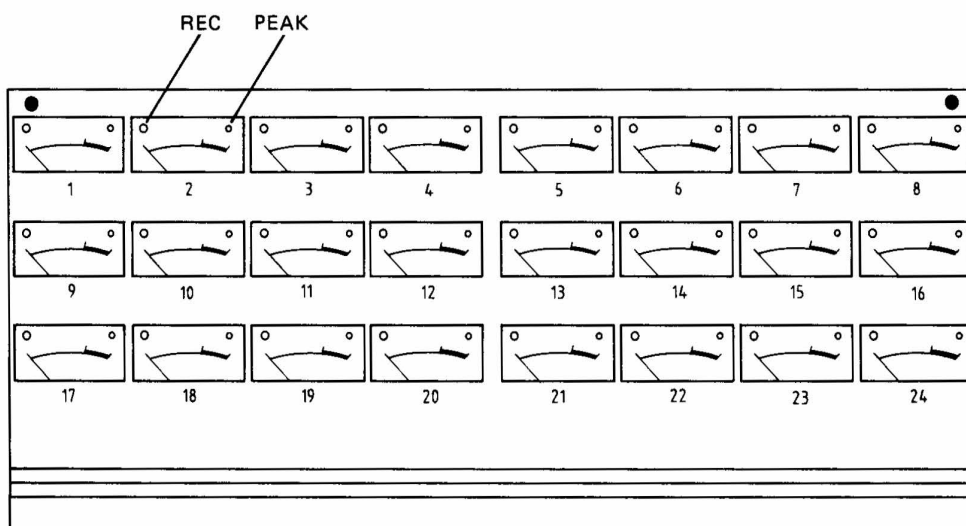

Figure 2-3 VU Meter Panel

The VU meters (16, 24 or 32 depending on the machine configuration) are located on the upper front panel of the machine. Each VU meter is calibrated to indicate 0 VU at the selected reference level (250 nWb/m or 320 nWb/m). Each meter incorporates two LED indicators, the PEAK indicator, which is set to illuminate if a signal peak reaches a level equivalent to 1,040 nWb/m (approximately 3% 3rd Harmonic Distortion), and the RECORD indicator, which flashes when the channel is in Record Ready mode, and is steadily illuminated when the channel is in Record or Spot Erase modes.



The 0 VU reference level and the level at which the PEAK LED becomes illuminated are adjustable via trimmers on each Audio Amplifier PCB.

## 2.3 AMPLIFIER CONTROLS (LOWER FRONT PANEL)

### 2.3.1 Audio Control PCB

(Numbers in brackets, [ ], refer to callouts in Figure 2-4.)

#### [1] Master BIAS SELECT switch (SW1) and trimmers

This switch selects between two preset bias levels to facilitate changing the bias level for two different tape formulations. The associated trimmers adjust the bias level for each switch position. Refer to Table 2-1.

The A HI SPD trimmer (VR1) adjusts the bias for the A position of the BIAS SELECT switch at high tape speed. The bias level for the A position at the Low tape speed is fixed for AMPEX 456 tape.

The B HI SPD trimmer (VR2) adjusts the bias for the B position of the BIAS SELECT switch at high tape speed.

The B LOW SPD trimmer (VR3) adjusts the bias for the B position of the BIAS SELECT switch at high tape speed.

Table 2-1 Bias Setting

|        | HI SPEED | LOW SPEED |
|--------|----------|-----------|
| TAPE A | VR 1     | fixed     |
| TAPE B | VR 2     | VR 3      |

#### [2] Reference flux level indicators (HI/LOW)

These Leds indicate the position of the REF FLUX switch [3]. The HI LED is illuminated when the selected reference level is 320 nWb/m\*. The LOW LED indicates that the selected reference level is 250 nWb/m\*.

Section 2

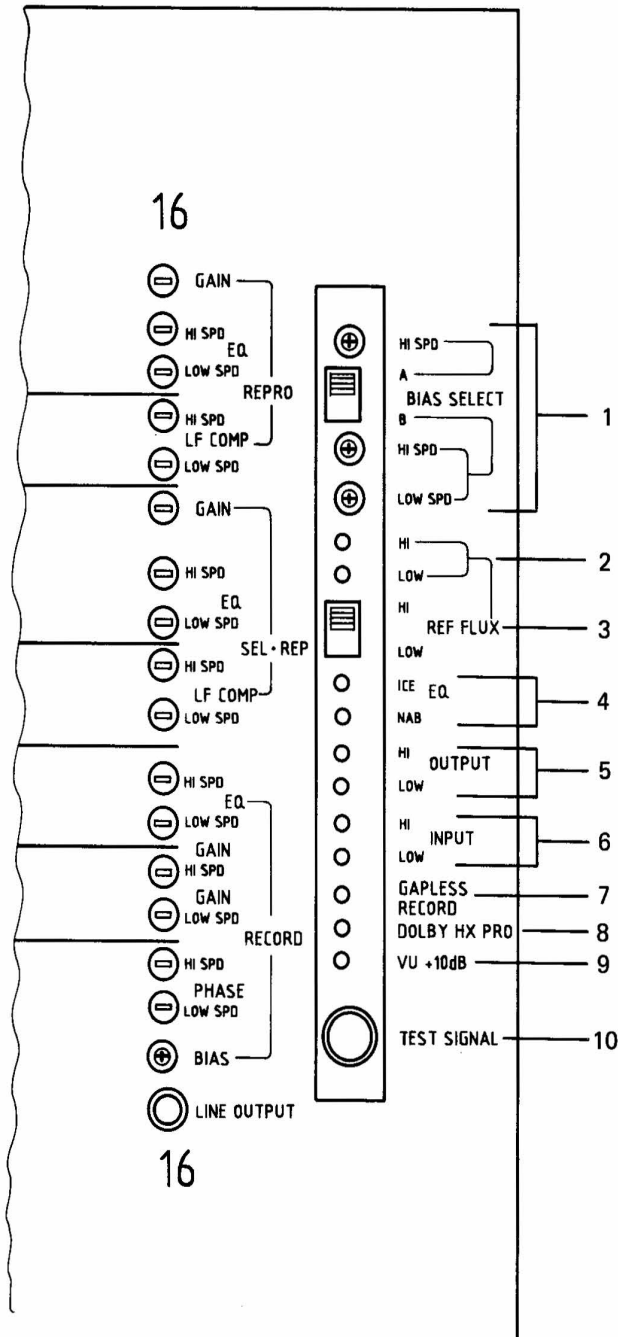

Figure 2-4 Audio Control PCB

[3] REF FLUX switch (SW2)

This switch selects either HI (320 nWb/m\*) or LOW (250 nWb/m\*) reference flux level (the magnetic flux density applied to, or playing from the tape when operating at 0 VU). Selection of reference level does not affect the input or output signal level.

\* NOTE: These values are default values at the time of shipment from the factory. They may be changed as required.

[4] EQualization indicators (IEC/NAB) and equalization select switch (SW3)

Selection of IEC or NAB equalization is made with SW3 on the Audio Control PCB. The indicator corresponding to the selected switch position will be illuminated.

[5] OUTPUT level indicators (HI/LOW) and level select switch (SW4)

Selection of the output level is made by SW4 located on the Audio Control PCB. At the time of shipment from the factory, the "HI" position corresponds to +4 dBm and the "LOW" position corresponds to -8 dBm. But these values can be changed as required.

The indicator corresponding to the selected switch position will be illuminated.

[6] INPUT level indicators (HI/LOW) and level select switch(SW5)

Selection of the input level is made by SW5 located on the Audio Control PCB. At the time of shipment from the factory, the "HI" position corresponds to +4 dBm and the "LOW" position corresponds to -8 dBm. But these values can be changed as required.

The indicator corresponding to the selected switch position will be illuminated.

[7] GAPLESS RECORD indicator and On/Off switch (SW6)

This switch controls the gapless record function. At the time of shipment from the factory, the switch is set to the On position. The indicator corresponding to the selected switch position will be illuminated.

## Section 2

### [8] DOLBY HX PRO indicator and On/Off switch (SW7)

This switch controls the Dolby HX Pro head room expansion function. At the time of shipment from the factory, the switch is set to the On position. The indicator corresponding to the selected switch position will be illuminated.

### [9] +10dB VU indicator and On/Off switch (SW8)

When this switch is On, the sensitivity of the VU Meters is increased by +10dB. At the time of shipment from the factory, the switch is set to the Off position. The indicator corresponding to the selected switch position will be illuminated.

### [10] TEST SIGNAL jack (PH1)

Any signal applied to this connector (1/4" phone jack) will appear at a test signal input to each audio channel. This connector is used to apply a test signal to all channels simultaneously for adjustment of gain, EQ, etc. The level of the signal applied to the TEST SIGNAL input should be the same as that applied to the rear panel input connectors (e.g., if the INPUT level select switch is set to LOW, an input signal of -8 dBm\* will cause the VU meter to indicate 0 VU, if the switch is set to HI, the test signal input must be +4 dBm\* for the VU meters to indicate 0 VU. (\* Or a value set elsewhere)

## 2.3.2 Serial Remote Control PCB

### [11] STOP STANDBY switch and indicator

Setting this switch to ON causes the Output of any channel that is in Record Ready mode to be fed from the Input whenever the tape stops, regardless of the position of the monitor switches. The indicator is illuminated when Stop Standby mode is selected.

### [12] FAST STANDBY switch and indicator

Setting this switch to ON causes the Output of any channel that is in Record Ready mode to be fed from the Input whenever the machine is in F.Fwd or Rewind or Spooling modes, regardless of the position of the monitor switches. Pressing the CUE button during wind temporarily overrides the Standby function.



The indicator is illuminated when Fast Standby mode is selected.

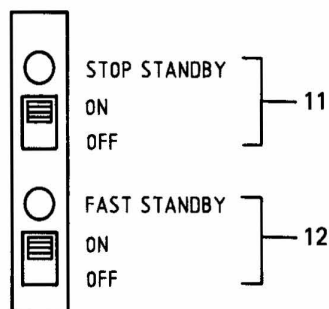

Figure 2-5 Serial Remote Control PCB

### 2.3.3 Audio Amplifier PCBs

The controls described here apply to one Audio Amplifier channel. Each audio channel has a corresponding set of controls.

#### [13] REPRO GAIN, EQ, LF COMP trimmers

These trimmers provide the following functions.

##### REPRO GAIN (VR5):

Adjustment of output level in playback.

##### REPRO EQ HI SPD (VR1):

Adjustment of playback equalizer in high speed.

##### REPRO EQ LOW SPD (VR2):

Adjustment of playback equalizer in low speed.

##### REPRO LF COMP HI SPD (VR3):

Compensation for the low frequency band characteristics at high speed.

##### REPRO LF COMP LOW SPD (VR4):

Compensation for the low frequency band characteristics at low speed.

Section 2

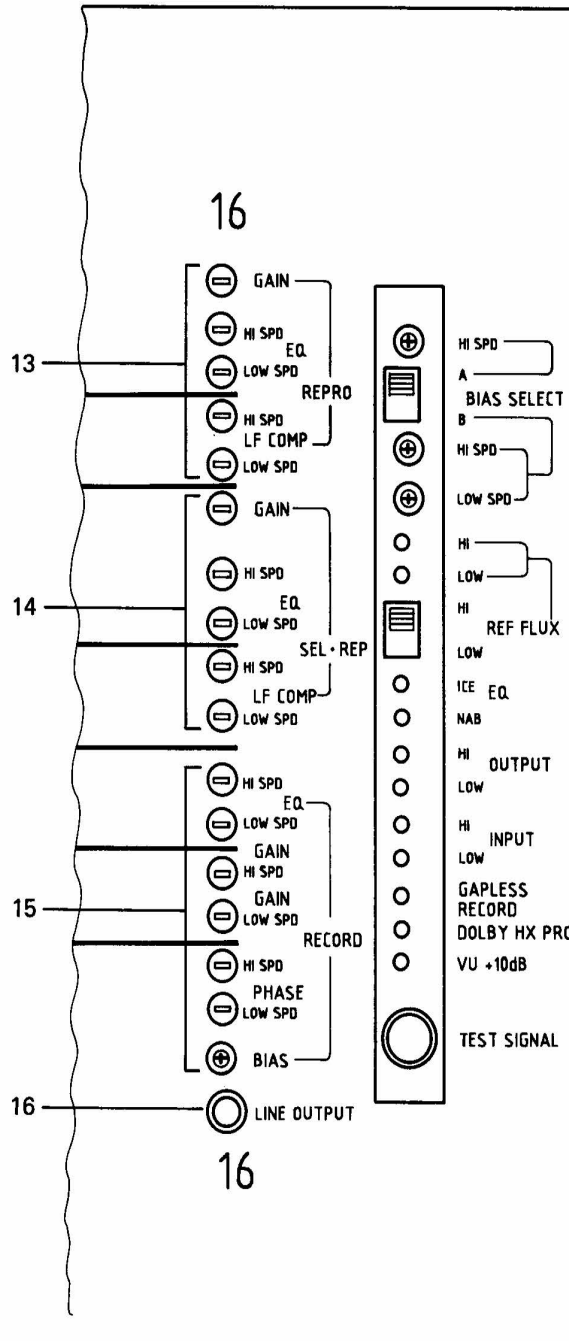

Figure 2-6 Audio Amplifier PCB

[14] SEL-REP GAIN, EQ, LF COMP trimmers

SEL-REP GAIN (VR10):

Adjustment of output level in sel-rep.

SEL-REP EQ HI SPD (VR6):

Adjustment of sel-rep equalizer (at high speed).

SEL-REP EQ LOW SPD (VR7):

Adjustment of sel-rep equalizer (at low speed).

SEL-REP LF COMP HI SPD (VR8):

Compensation for the low frequency band characteristics in sel-rep (at high speed).

SEL-REP LF COMP LOW SPD (VR9):

Compensation for the low frequency band characteristics in sel-rep (at low speed).

[15] RECORD EQ, GAIN, PHASE, BIAS trimmers

RECORD EQ HI SPD (VR15):

Adjustment of record equalizer at high speed.

RECORD EQ LOW SPD (VR16):

Adjustment of record equalizer at low speed.

RECORD GAIN HI SPD (VR17):

Adjustment of record level at high speed.

RECORD GAIN LOW SPD (VR18):

Adjustment of record level at low speed.

RECORD PHASE HI SPD (VR19):

Adjustment of phase compensation at high speed.

RECORD PHASE LOW SPD (VR20):

Adjustment of phase compensation at low speed.

RECORD BIAS (VR21): Adjustment of bias current.

[16] LINE OUTPUT connector

This 1/8" (3 mm) 2-circuit (Tip-Ring-Sleeve) phone jack connector provides a "front panel" Line Output in parallel with the rear panel Output connector. The output is either balanced or unbalanced as selected by the BAL/UNBAL switch (SW1) on the Audio Amplifier PCB. This connector is most useful as a test connector when making Phase Comp adjustments.

## Section 2

### 2.4 POWER SUPPLY PANEL

This panel contains the POWER switch, the Power Indicator, and the power supply circuit breakers. There is one circuit breaker for each of the supply voltages. When power is applied to the machine, and the POWER switch is in the On position, the VU Meters are illuminated. The Power Indicator changes color from Red to Green shortly after the Power is turned On, indicating that the power supply circuits are functioning normally.

The circuit breakers have been provided to protect the circuitry in case trouble should develop. If a circuit breaker should trip, turn off the machine, wait 30 seconds, press the circuit breaker to reset it, and turn the machine back on. If the problem reoccurs or continues, contact your OTARI dealer or OTARI. See page iv for OTARI's location nearest you.

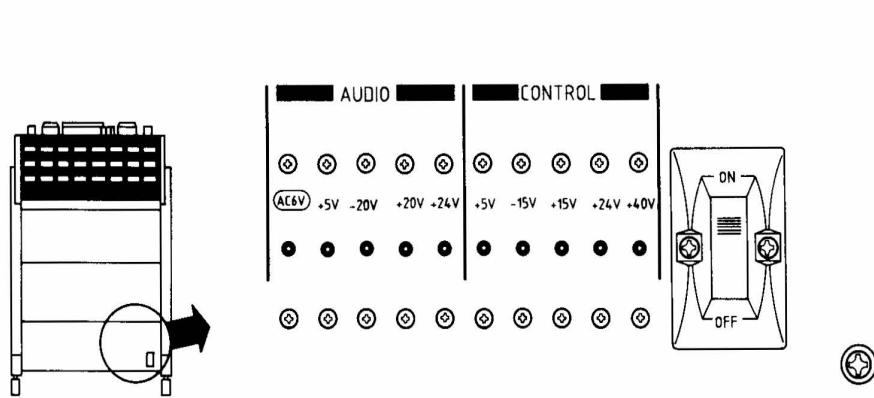

Figure 2-7 Power Supply Panel

### 2.5 INPUT AND OUTPUT CONNECTORS

All input and output connections except AC power, are made at the Connector Panel on the lower rear of the machine.

There are 3 pin XL type connectors for audio line Inputs and Outputs. Multi-pin connectors are provided for the Remote Control Unit and Noise Reduction system control. A Parallel I/O connector is provided for the optional CB-119 Auto Locator or other machine controller (e.g., SMPTE time code based synchronizer). Optional Serial I/O panels provide interfaces to RS-232C and RS-422A (SMPTE/EBU BUS) control systems.



NOTE: Refer to Section 6.3 for further information about I/O connectors and pin assignments.

Numbers in brackets [ ] refer to callouts in Figure 2-8.

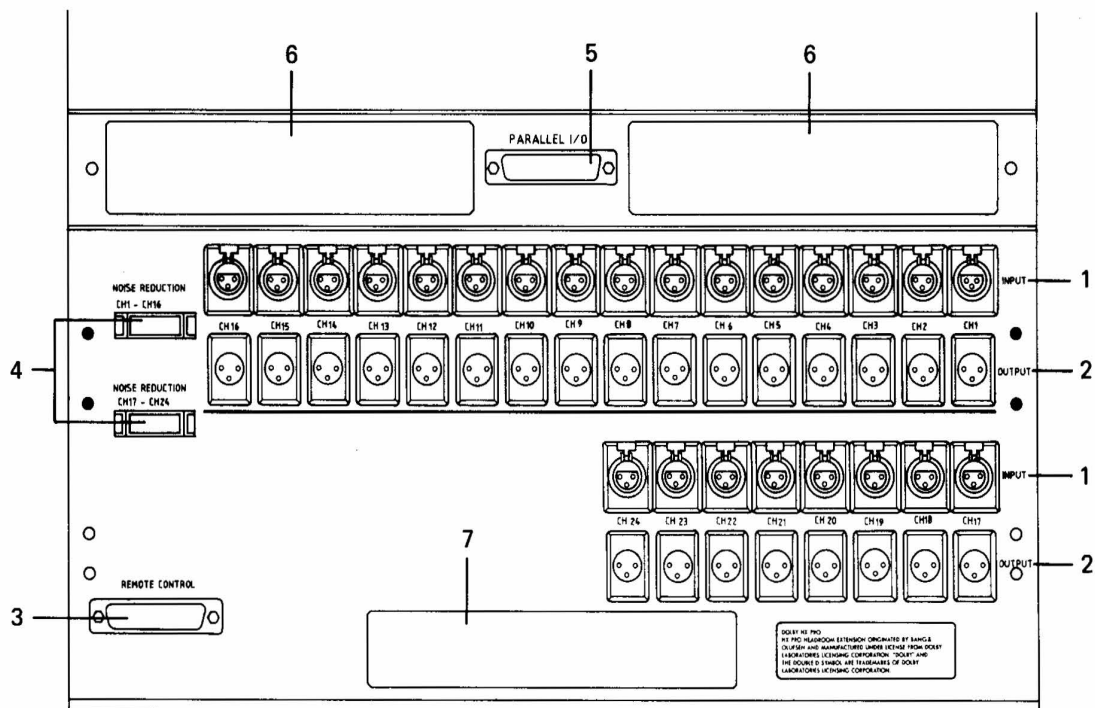

Figure 2-8 Rear Panel I/O connectors

[1] INPUT connectors

These 3-pin XL type connectors are the audio signal inputs to each channel of the recorder. Connect the buss or track outputs of the mixing console to these INPUT connectors. The MX-80 Inputs are designed for use with "line level" signals at either -8 dBm (-10 dBV) or +4 dBm (selectable via a switch on the Audio Control PCB).

[2] OUTPUT connectors

These 3-pin XL type connectors are the audio signal outputs from each channel of the recorder. Connect the track or monitor inputs of the mixing console to these OUTPUT connectors. The output from these connectors is at "line level", either -8 dBm (-10 dBV) or +4 dBm.

## Section 2

### [3] REMOTE CONTROL connector

This connector is used to connect the CB-123/124 Remote Control Unit to the tape recorder.

### [4] NOISE REDUCTION connector

These 34-pin connectors are used to provide mode control of any non-simultaneous external noise reduction system which requires machine control of Encode/Decode modes. These connectors provide a "dry-contact" relay closure when the channel is in Input monitor or Record mode.

### [5] PARALLEL I/O connector

This 37-pin connector is used to provide interface signals to the optional CB-119 Auto Locator or machine controller (e.g., synchronizer or resolver).

### [6] Serial I/O Interface panel (Optional)

This optional Interface panel is used to connect the transport to control signals meeting RS-232C or RS-422A (SMPTE/EBU BUS) standards.

### [7] (Optional I/O panel)

## 2.6 REMOTE CONTROL UNIT - CB-124 (16 or 24CH) OR CB-123 (32CH)

The CB-124 and CB-123 Remote Control Units are designed specifically to be used with the 16 or 24 track and 32 track versions of the MX-80 Series respectively. Many of the functions of the tape recorder such as the selection of a channel for recording, are controlled exclusively from the Remote Control Unit. Other functions, such as basic transport control, are available at both the transport and the Remote Control Unit. The numbers in brackets [ ] refer to callouts in Figure 2-9.

### [1] F.FWD button

Pressing this button places the transport in Fast Forward wind mode. The button will be brightly illuminated (white).

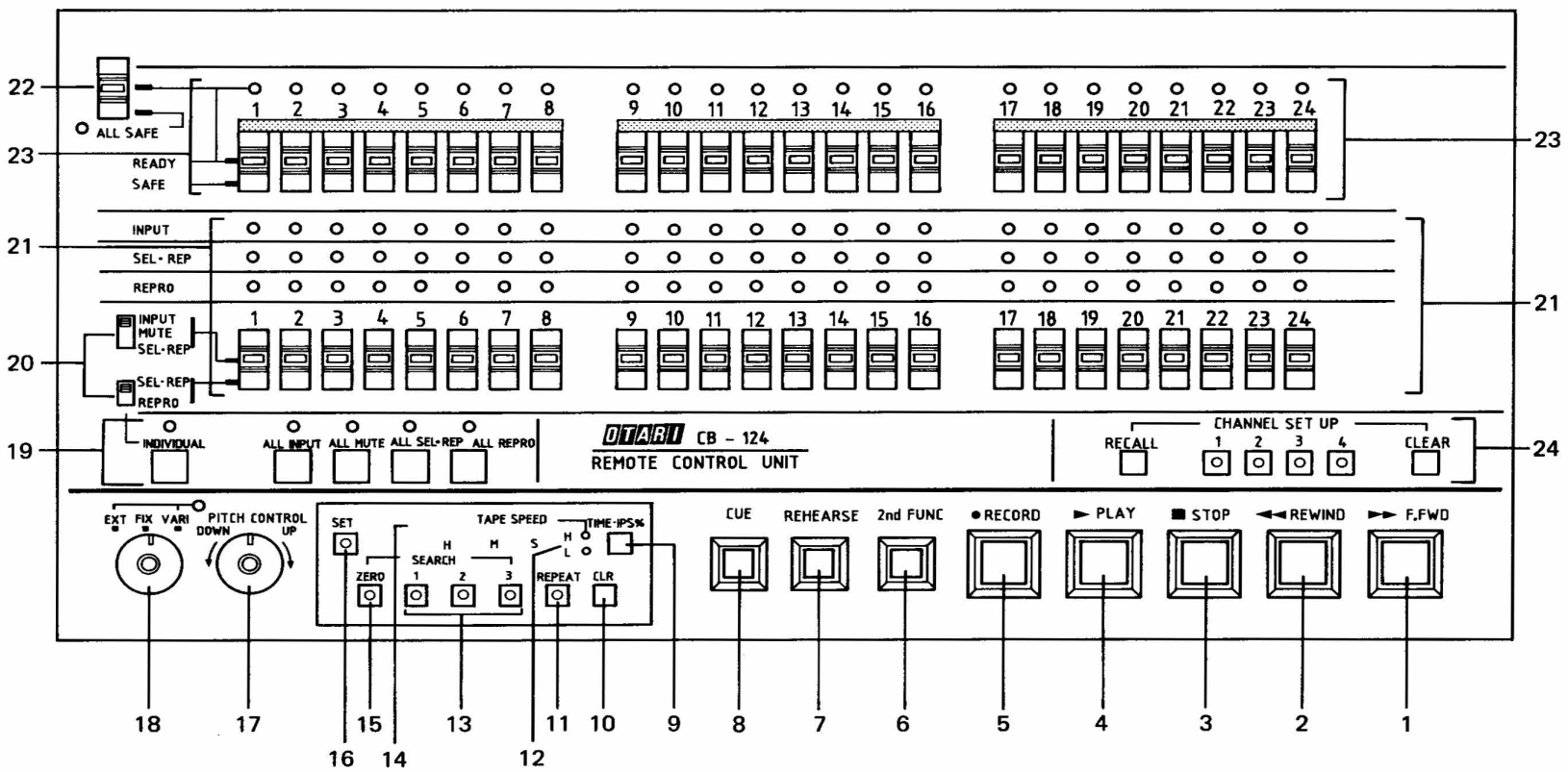

Figure 2-9 Remote Control Unit Controls and Indicators

## Section 2

Keeping the F.FWD button pressed, and then pressing the 2nd FUNC button places the transport in Forward Spooling mode for winding tape onto the take-up reel with a smoother tape pack than is achieved at full wind speed.

### [2] REWIND button

Pressing this button places the transport in Rewind mode. The button will be brightly illuminated (white).

Keeping the REWIND button pressed and then pressing the 2nd FUNC button places the transport in Reverse Spooling mode for winding the tape onto the supply reel with a smoother tape pack than is achieved at full wind speed.

### [3] STOP button

Pressing the STOP button when the transport is in Play, Reverse Play, F.Fwd, Rewind, Edit Play or Spooling mode, causes the tape motion to stop. The button will become brightly illuminated (blue)

Pressing this button when the transport is in Unload mode and the STOP button is flashing, (such as when tape has just been threaded, and the slack has been removed by turning the reels by hand) causes the transport to apply tension to the tape in preparation for other transport modes. The button will become brightly illuminated (blue).

Pressing the 2nd FUNC button simultaneously with the STOP button causes the capstan motor to reverse direction in preparation for Reverse Play mode.

NOTE: There is a slight delay while the capstan motor achieves crystal-locked speed, when reversing.

### [4] PLAY button

Pressing this button places the transport in Play mode, causing tape to wind onto the take-up reel at the selected Speed (H or L). The button will become brightly illuminated (white).

Pressing the PLAY button while in F.Fwd or Rewind mode causes the tape to decelerate and then enter the Play mode.

Pressing this button while the transport is in Edit Ready mode (with the EDIT/UNLOAD button flashing) causes the transport to enter Dump Edit (Edit Play) mode.



Pressing this button while the transport is in Search Cue or Search Zero modes causes PLAY button to flash and the transport to enter Play mode upon reaching the end of the Search.

Pressing the PLAY and 2nd FUNC buttons simultaneously causes the transport to enter Reverse Play mode.

[5] RECORD button

When a channel is in Record Ready mode the RECORD button will flash (red). You may select one of two methods of entering Record mode. The two methods are:

1. Pressing this button simultaneously with the PLAY button. The button will be brightly illuminated (red).
2. Pressing this button while the transport is in Play mode (also known as Punch-In). The button will be brightly illuminated (red).

The MX-80 is factory preset for method 2.

Similarly, you may select between two methods of exiting from Record mode:

1. Keeping the RECORD button pressed and pressing the STOP button (Punch-Out).
2. Pressing the PLAY button while in Record mode.

The MX-80 is factory preset for method 2.

The selection of Punch-In and Punch-Out methods is made via switches DSW3-1 and DSW3-2 on the Transport Control PCB.

Pressing this button simultaneously with 2nd FUNC button causes the transport to enter Spot Erase Ready mode. Pressing the RECORD button again, and holding it, while slowly moving the tape by hand, causes the erase circuitry to be activated to erase the tape at the Erase Head. Releasing the RECORD button will deactivate the Erase signal.

Pressing this button while the transport is in Reverse Play mode causes the MX-80 to enter Reverse Erase mode.

## Section 2

### [6] 2nd FUNC button

Pressing the 2nd FUNC button with other buttons provides access to additional functions which are not labeled on the machine. Each function is described with the appropriate button.

### [7] REHEARSE button

Pressing the REHEARSE button causes the machine to enter Rehearsal mode. When a Punch-In is preformed in Rehearsal mode, the monitor output of any channel which in Record Ready mode will be switched to Input monitor at the moment that the RECORD button is pressed, though actual recording is not performed. To exit from Rehearsal mode, press the REHEARSE button again.

### [8] CUE button

Holding the CUE button pressed causes the tape lifters to remain retracted only as long as the button is held pressed. Tapping the CUE button causes the tape lifters to remain retracted until the next time the CUE button is pressed. When the lifters are retracted, the audio output is attenuated and the high frequencies rolled-off to prevent damage to the monitor speakers.

When the CUE button is pressed, and the lifters are not retracted, the audio is unmuted and is not attenuated, allowing you to listen for slate or marker tones without winding the tape across the heads. Press the CUE, STOP or PLAY button to leave Cue mode.

Pressing this button while in Stop mode causes the machine to enter Stop Cue mode.

Pressing either the F.FWD or REWIND button while in Stop Cue mode allows the audio to be monitored and the tape to be wound in the direction indicated. Depending upon the setting of DSW1-3 on the Transport Control PCB, the lifters will remain retracted, and the audio attenuated, as described above, or the lifters will not retract, and the audio is unmuted and not attenuated.

## [9] TIME-IPS-% button

Pressing this button causes the Tape Timer display to show the Tape Time, the selected Play Speed in ips, or the Percentage of Play Speed, in turn.

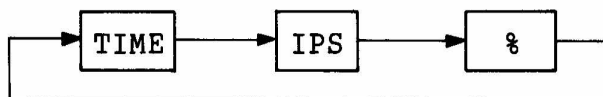

## [10] CLR button

Pressing this button simultaneously with another button clears the selected function as follows:

CLR + SET ..... Set mode is canceled.

CLR + TIME-IPS-% ... The Tape Timer display is cleared to 0.00.00.

CLR + SEARCH 1 - 3 .. The stored cue point is cleaned

## [11] REPEAT button

Pressing the REPEAT button, and then pressing any two illuminated Cue buttons (ZERO, 1, 2, and 3), causes the machine to enter Repeat mode. Then pressing the PLAY button, causes the machine to play from the first location to the second, Rewind to the first location and Play again, repeating until Repeat mode is deactivated.

## [12] TAPE SPEED (H/L) indicator

This LED indicates the position of the SPEED SELECT switch on the MX-80 transport.

## [13] SEARCH 1, 2 and 3 buttons

If a button is not illuminated, there is no tape location stored for that Cue Point. Pressing an unlit SEARCH 1 - 3 button causes the current time shown on the Tape Timer display to be stored as that Cue Point, and that button to become illuminated.

If a SEARCH 1 - 3 button is illuminated, a tape location has been stored for that Cue Point. Pressing that button causes the transport to search to the location stored as that Cue Point. The location will be displayed on the Tape Timer display for approximately 2 seconds at the beginning of the search.



## Section 2

Pressing the PLAY button while in Search mode causes the PLAY button to flash, and when the tape reaches the location being searched to, the transport will enter Play mode.

Pressing the STOP button together with any SEARCH 1 - 3 button causes the Tape Time display to show the location stored for that button.

Pressing CLR button together with any SEARCH 1 - 3 button will cause the location stored for that button to be cleared.

NOTE: There are different SEARCH 1,2,3 buttons on the Transport Control Panel which store the different Cue Points from those on the Remote Control Unit. Another words, all together 6 Cue Points can be stored with the MX-80.

### [14] Tape Timer display (H.M.S.)

The Tape Timer displays the current tape time in Hour, Minute, Second format. If the tape is located behind the 0.00.00 position the Tape Timer will display the time as negative (or -) time, relative to 0.00.00. If the SPEED SELECT switch is changed, the Tape Timer automatically recalculates the time displayed to be correct for the new speed.

The Tape Timer display is also utilized to display any error messages resulting from the Power-On self-test.

### [15] SEARCH ZERO button

Pressing this button causes the transport to F.Fwd or Rewind the tape, stopping when the Tape Timer reads 0.00.00.

Pressing the PLAY button while in Search Zero mode causes the PLAY button to flash and when the tape reaches 0.00.00, the transport enters Play mode.

Pressing the STOP, F.FWD, or REWIND button while in Search Zero mode causes the machine to leave Search Zero mode and take the action directed by the button.

### [16] SET button

Pressing this button causes the MX-80 to enter Set mode, in which the tape times for three cue points can be entered using the following buttons:



|                    |                        |
|--------------------|------------------------|
| SEARCH ZERO .....  | + or - sign            |
| SEARCH CUE 1 ..... | Hours digit            |
| SEARCH CUE 2 ..... | Tens of Minutes digit  |
| SEARCH CUE 3 ..... | Units of Minutes digit |
| REPEAT .....       | Tens of Seconds digit  |
| CLR .....          | Units of Seconds digit |

The selected digit will increment each time the button is pressed.

To store the tape time which has been entered onto the display in Set mode as a cue point, press and hold the SET button, and then press the desired SEARCH CUE button.

[17] PITCH CONTROL knob

When the Speed Mode Selector switch [18] is set to VARI, this multiturn control adjusts the tape speed  $\pm 50\%$ .

[18] Speed Mode Selector switch (EXT/FIX/VARI)

This switch selects the speed reference for the capstan motor from three options:

**FIX:** The tape speed is fixed at the speed selected by the SPEED SELECT switch on the transport. The speed is locked to the MX-80's internal crystal controlled speed reference.

**EXT:** The tape speed is determined by the frequency of an EXTERNAL speed reference signal. EXTERNAL control is used when the tape speed is to be controlled by a synchronizer, resolver or other similar device. The signal should be 9,600 Hz for nominal tape speed. If the Speed Mode Selector switch is set to EXT, and the PITCH ENABLE line (pin 23) of the Parallel I/O connector is set to low logic level, the speed of the Capstan Motor can be controlled by an external 9600 Hz signal applied to Pin 20 of the Parallel I/O connector. Refer to Section 3.2.14 for further information regarding external control of the Capstan Motor speed.

## Section 2

VARI: The tape speed is determined by the setting of the PITCH CONTROL [17]. The tape speed is adjustable  $\pm 50\%$ .

The red LED illuminates when VARI is selected, and flashes when the PITCH ENABLE line on the Parallel I/O connector is at logic level Low.

### [19] INDIVIDUAL, ALL INPUT, ALL MUTE, ALL SEL REP, ALL REPRO buttons

When the INDIVIDUAL button is pressed, the Monitor mode (Input, Sel-Rep, Repr, Mute) of each channel can be selected individually with the Output Selector Switches.

When the ALL INPUT button is pressed, all channels will change to Input mode regardless of the positions of their Output Selector switches.

When the ALL MUTE button is pressed, all channels will change to Mute mode regardless of the positions of their Output Selector switches.

When the ALL SEL-REP button is pressed, all channels will change to the Sel-Rep Monitor mode regardless of the positions of their Output Selectors.

When the ALL REPRO button is pressed, all channels will change to the Repr Monitor mode regardless of the positions of their Output Selectors.

### [20] Output Preset switches

These switches preset the monitor modes which can be selected with the Output Selector switches [21].

NOTE: When Stop Standby or Fast Stadbby modes are activated (with switches on the Serial Remote Control PCB), the Mute function is disabled. If a channel is set to Mute mode, or ALL MUTE is pressed, the channel will change to Input monitor mode when the machine is in Fast Wind or Stop.

### [21] Output Selector switches and Mode Indicators

When the upper Output Preset switch has been set to INPUT, and the INDIVIDUAL button pressed, setting one of these switches to the upper position causes that channel's output to be the signal present at that channel's input (Input Monitor mode).

When the upper Output Preset switch has been set to MUTE, and the INDIVIDUAL button pressed, setting one of these switches to the upper position causes that channel's output to be Muted.

When either Output Preset switch has been set to SEL-REP, and the INDIVIDUAL button pressed, setting one of these switches to the corresponding position causes that channel's output to be the signal on tape played back by the Record head (Sel-Rep Monitor mode).

When either Output Preset switch has been set to REPRO, and the INDIVIDUAL button pressed, setting one of these switches to the corresponding position causes that channel's output to be the signal on tape played back by the Repr head (Repro Monitor mode).

The MODE indicators show each channel's Monitor status. Table 2-2 below describes the relationship between Record mode, switch position, and LED indicator.

Table 2-2 Monitor Mode Indicators

| Switch Position | Mode   | Indicator          |
|-----------------|--------|--------------------|
| INPUT           | RECORD | INPUT (Yellow)     |
| SEL-REP         | RECORD | INPUT (Yellow)     |
|                 | SAFE   | SEL-REP (Green)    |
| REPRO           | ----   | REPRODUCE (Orange) |

#### [22] ALL SAFE switch

Setting this switch to ALL SAFE position puts all channels into Record Safe mode and illuminates the green ALL SAFE LED (the Channel READY/SAFE switches have no effect on the channel's Record status). When the ALL SAFE position is not selected, the Record Ready status of a channel is determined by that channel's READY/SAFE switch.



## Section 2

## [23] READY/SAFE switches and mode indicators

When the ALL SAFE switch is not engaged, these switches determine the Record Ready status of each channel. If a channel's READY/SAFE switch is engaged (in the Ready position), the associated LED will flash, the RECORD button will flash, and the channel will enter Record mode when the RECORD button (or RECORD and PLAY) on the Remote Control unit or transport is pressed. When a channel is in Record mode, the LED indicator will be steadily illuminated.

Table 2-3 below describes the condition of the LED and RECORD button indicators for various combinations of switch position and transport mode.

Table 2-3 Record Indicator and Modes

| Switch position | Transport mode | Indicator (red) | RECORD button lamp (red) |
|-----------------|----------------|-----------------|--------------------------|
| SAFE            | Non-recording  | Off             | Off                      |
|                 | Recording      | Off             | On                       |
| READY           | Non-recording  | Flash           | Flash                    |
|                 | Recording      | On              | On                       |
|                 | Recording      | Flash           | On                       |

## [24] CHANNEL SET-UP buttons

Pressing one of these buttons, when that button is not illuminated, causes the current READY/SAFE, MUTE/INPUT/SEL-REP/REPRO status of all channels to be stored in that memory and the button to become illuminated.

Pressing one of these buttons, when that button is illuminated, causes the channel status stored in that memory to be displayed.

Holding the RECALL button pressed and then pressing any of the illuminated CHANNEL SET-UP buttons causes all the channels to be set to the READY/SAFE, MUTE/INPUT/SEL-REP/REPRO status which was stored in that memory. The CHANNEL SET-UP button will flash.



Section 2

Holding the CLR button pressed and then pressing any of the illuminated CHANNEL SET-UP buttons causes the channel status stored in that memory to be cleared.

## SECTION 3: OPERATION

This section contains, first, a list and an accompanying explanation of each of the many operating conditions (or modes) of the MX-80, and second, a tutorial covering the tape recorder-related tasks involved in making recordings. You should read both parts of this Section when first becoming familiar with the machine, and again as a guide while you are learning to operate the machine. The portion describing the Operating Modes provides a quick reference, while the Tutorial portion provides hands-on instructions about how to operate the machine. Information regarding Installation and Hook-up of the machine is contained in Section 6 of this manual. If you are uncrating and hooking up the machine for the first time, please refer to the information in Section 6 before continuing with this Section.

3.1 MODES OF OPERATION

| Mode         | Control                      | Operation   |
|--------------|------------------------------|---|
| Play         | PLAY                         | Tape moves from Supply to Take-up at the currently selected speed.        |
| Reverse Play | PLAY + 2nd<br>FUNCTION       | Tape moves from Take-up to Supply at the currently selected speed.        |
| Record       | RECORD<br>(or RECORD & PLAY) | Any channel in Record Ready begins to record.                             |
| Ready        | READY/SAFE                   | The selected channel will enter Record when the RECORD button is pressed. |
| Safe         | READY/SAFE                   | The selected channel will not enter Record.                               |
| Stop         | STOP                         | Tape motion stops.  |
| Reverse Stop | STOP + 2nd<br>FUNCTION       | Tape motion stops and the Capstan reverses its rotation.                  |
| F.Fwd        | F.FWD                        | Tape moves from Supply reel to Take-up at wind speed.                     |

Section 3

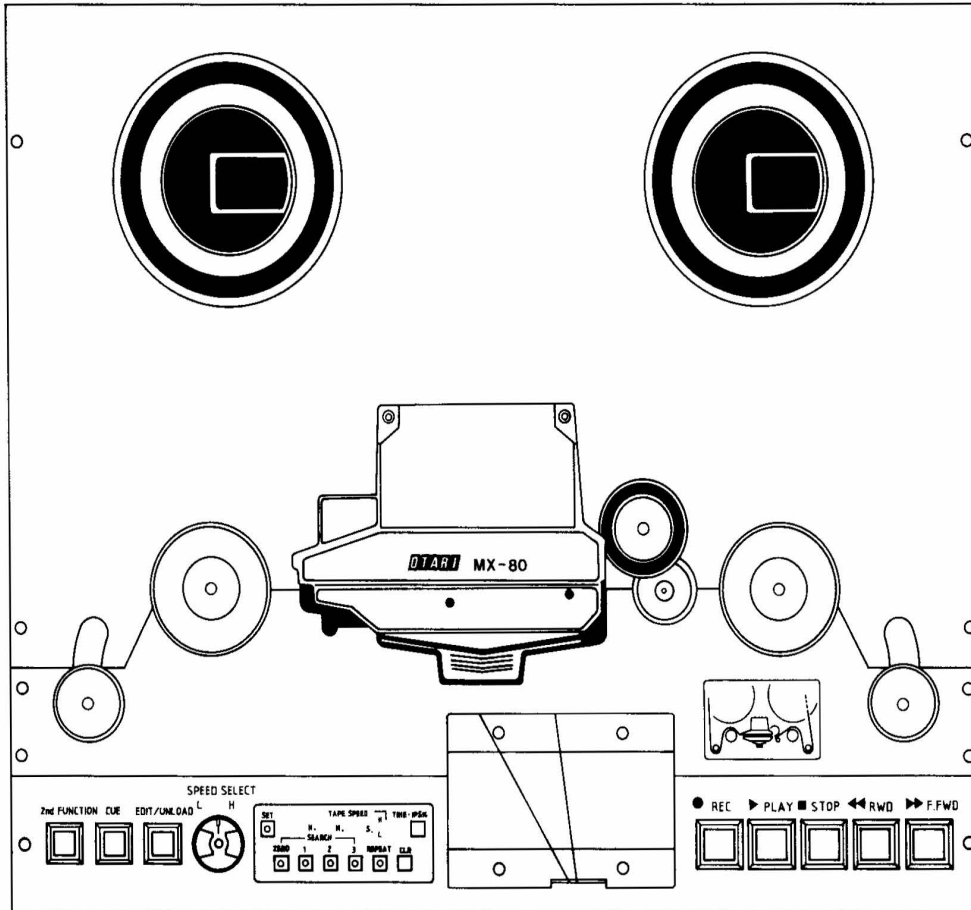

Figure 3-1 Transport Features

| Mode       | Control     | Operation   |
|------------|-------------|---|
| Rewind     | REWIND      | Tape moves from Take-up reel to Supply reel at wind speed.              |
| Edit Ready | EDIT + STOP | Transport is prepared for next Edit mode.                               |
| Dump Edit  | EDIT + PLAY | Tape moves toward the Take-up reel but the Take-up motor does not turn. |

| Mode             | Control                                   | Operation  |
|------------------|---|--|
| Unload           | EDIT/UNLOAD<br>Twice                      | The tension on the tape is released.   |
| Stop Cue         | STOP + CUE                                | The lifters move out in preparation for another Cue mode.  |
| Spooling Cue     | Stop Cue +<br>F.FWD or REW                | Tape moves at 120 ips and audio can be monitored.  |
| Fast Winding Cue | F.Fwd or Rew<br>+ CUE                     | The lifters retract and the tape contacts the heads for monitoring audio.  |
| Spooling Wind    | 2nd FUNCTION<br>+ F.FWD or<br>REW         | Tape is wound in the direction selected at approximately 120 ips for library winding for storage. Audio is muted.        |
| Input Monitor    | ALL INPUT or<br>INDIVIDUAL +<br>INPUT     | The signal at the MX-80 Output is the signal at the Input.   |
| Sel-Rep          | ALL SEL-REP<br>or INDIVIDUAL<br>+ SEL-REP | The signal at the MX-80 Output is the signal on tape reproduced by the Record Head.                                      |
| Repro            | ALL REPRO or<br>INDIVIDUAL +<br>REPRO     | The signal at the MX-80 Output is the signal on tape reproduced by the Repro Head.                                       |
| Search Zero      | SEARCH ZERO                               | Tape is moved at wind speed to the location corresponding to 0.00.00 on the Tape Timer.                                  |
| Search Cue       | SEARCH 1 - 3                              | Tape is moved at wind speed to the location corresponding to the Tape Timer reading stored with the SEARCH 1 - 3 button. |
| Search Play      | SEARCH CUE +<br>PLAY                      | Tape is moved at wind speed to the stored location, where the tape enters Play.  |



Section 3

| Mode          | Control                        | Operation   |
|---------------|--------------------------------|---|
| Stop Erase    | 2nd FUNCTION<br>+ RECORD Twice | The Erase head for the channel in Record Ready will be activated and the tape will move from Take Up to Supply. |
| Reverse Erase | 2nd FUNCTION<br>+ PLAY + REC   | The erase head for the channel in Record Ready will be activated and the tape will move from Take Up to Supply. |
| Stop Standby  | STOP STANDBY<br>On             | All channels in Record Ready will be set to Input Monitor whenever tape stops.                                  |
| Fast Standby  | FAST STANDBY<br>On             | All channels in Record Ready will be set to Input Monitor whenever tape is in F.Fwd or Rewind.                  |

### 3.2 RECORDING WITH THE MX-80 - A TUTORIAL

#### 3.2.1 Threading the Tape on the Machine

- (1) Set the POWER switch [Figure 2-6] to the On position. It is located on the Power Supply Panel at the bottom of the machine pedestal. The VU meter lamps will become illuminated.
- (2) Lift up the clamp levers on the top surface of the reel turntables to unlock them so they will accommodate the reel.  
Place an empty reel on the machine. If the tape is "heads" out, place the empty reel on the Take-up reel turntable. If the tape is "tails" out, place the empty reel on the Supply reel turntable.

NOTE: There is a locating pin near the bottom of each reel turntable. In order for the reel to be seated firmly against the reel turntable, be sure one of the slots in the reel hub is aligned with the locating pin. When the reel is seated, push down on the clamp lever causing the clamp ring to expand and firmly grip the reel hub. Check to be sure the reel is seated firmly against the reel turntable.

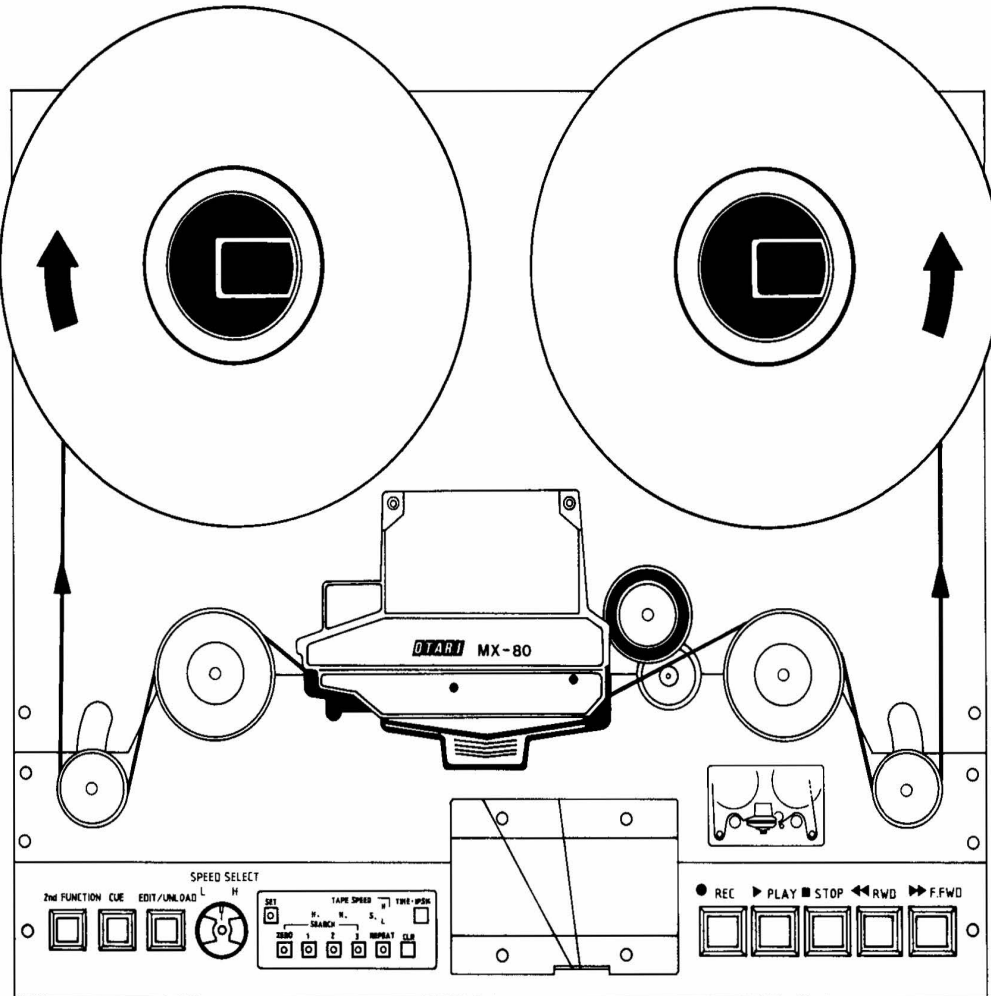

Figure 3-2 Tape Threading

- (3) Pull about 4 feet of tape from the reel, and thread it around the left Tension Arm and Guide Roller, across the Head Assembly, between the Capstan and Pinch Roller, around the Tachometer Roller and the right Tension Arm, and onto the Take-up reel, exactly as shown in Figure 3-2 and on the transport of the MX-80.

### Section 3

- (4) Rotate the Take-up reel counterclockwise, and the Supply reel clockwise, by hand, to take up any slack in the tape and to lift the Tension Arms up toward the center of the transport. The STOP button will begin to flash.
- (5) Press the STOP button [Figure 2-1, 3] to apply tension to the tape and prepare the transport for further functions. The STOP button will become brightly illuminated. It is not necessary to perform this step, (you can go directly from Unload to Play or Wind), but we recommend that you develop the habit of pressing STOP to insure there is no slack in the tape before proceeding to other operations to prevent any possible damage to tape or machine caused by the sudden movement of tape.

#### 3.2.2 Recording the Basic Tracks

- (1) Thread the tape on the transport as described in Section 3.2.1.
- (2) Set the SPEED SELECT switch [Figure 2-1, 6] to the desired tape speed. On high speed-pair machines L is 15 ips and H is 30 ips. On low speed-pair machines, L is 7-1/2 ips and H is 15 ips. Set the Speed Mode Selector switch [Figure 2-9, 18] to the FIX position.
- (3) Press the RESET button, either on the transport or on the Remote Control unit, to reset the Tape Timer to 0.00.00.
- (4) Set the ALL SAFE switch on the Remote Control unit to the Ready position.
- (5) Set the READY/SAFE switch for the track on which you wish to record to the Ready position. The READY LED above that switch will be illuminated, and the RECORD button will flash indicating that the channel is in Record Ready mode.
- (6) Set the upper Outout Preset switch [Figure 2-9, 20] to the INPUT position. Set the Output Selector switches [Figure 2-9, 21] for the selected channel(s) to the upper (Input) position, or press the ALL INPUT button. The corresponding INPUT indicator(s) will become illuminated.



- (7) Adjust the signal level at the mixing console or signal source. The output of the console should be set for the same level range as the input of the MX-80. Refer to Section 6.4 for more information about setting console and MX-80 levels.
- (8) It is good practice to record reference tones at the head of every session tape for later level matching. If you use reference tones, adjust the level at the console for a meter indication of 0 VU.
- (9) Press the PLAY and RECORD buttons simultaneously to cause the MX-80 to begin recording on the selected tracks. See Section 2.1 for more information about selecting the method of entering and leaving Record mode.
- (10) There are several ways to end recording.  
To end the recording and stop the tape, press the STOP button.  
To end the recording on all tracks and have the tape continue in Play (rolling punch-out), press the PLAY or PLAY and RECORD buttons (depending upon the setting of DSW1 on the Transport Control PCB, see Section 2.1), or set the ALL SAFE switch to the All Safe position.  
To end the recording on one or more tracks, while other tracks continue to record, move the READY/SAFE switches for those tracks to the SAFE position.

### 3.2.3 Playing Back the Basic Tracks

- (1) Rewind the tape to the beginning of the recording by pressing SEARCH ZERO (if the Tape Timer was reset at the beginning), or by pressing the REWIND button.
- (2) Set the ALL SAFE switch to the All Safe position to avoid accidentally erasing recorded tracks. The ALL SAFE LED will become illuminated.
- (3) Set the lower Output Preset switch [Figure 2-9, 20] to the REPRO position. Set the Output Selector switches [Figure 2-9, 21] for the selected channel(s) to the lower (Repro) position, or press the ALL REPRO button. The corresponding REPRO indicator(s) will become illuminated.
- (4) Press the PLAY button. The signal on the tape will be reproduced by the Repro head and fed to the Output connectors.
- (5) Adjust the monitor level at the mixing console.



## Section 3

### 3.2.4 Recording Overdubs Using Sel-Rep Playback

Overdubs are performed when it is necessary to add additional tracks in sync with material already recorded on some of the tracks. During Sel-Rep playback the previously recorded material is reproduced by the record head making it possible to add (overdub) tracks without the delay caused, during normal playback, by the space between the Record and Repro heads. When overdubs are recorded, the previously recorded tracks are played in Sel-Rep and monitored by the performer through the mixing console. The new material is then recorded in sync with the existing tracks.

- (1) Rewind the tape to the beginning of the section to be overdubbed.
- (2) Set the ALL SAFE switch to the Ready position, and set the READY/SAFE switches to Safe for the all the tracks on which no new material will be recorded.
- (3) Set the READY/SAFE switches to Ready for the tracks on which new material is going to be recorded. The READY LEDs for those tracks will flash.
- (4) Set the upper Output Preset switch [Figure 2-9, 20] to the Input position. Set the lower Output Preset switch to the Sel-Rep position. Set the Output Selector switches [Figure 2-9, 21] to the lower (Sel-Rep) position for all the channels, or press the ALL SEL-REP button. The INPUT LEDs will be illuminated for the channels which are in Record Ready mode, if the STOP STANDBY switch [Figure 2-5, 11] is On.
- (5) Press the PLAY and RECORD buttons simultaneously to begin overdubbing. Adjust the recording and monitor levels at the mixing console.

### 3.2.5 Recording Punch-In Overdubs

Punch-In overdubs are performed when it is necessary to insert new material into a track that has already been recorded, without re-recording the entire track. Punch-in overdubbing allows you to monitor the previously recorded material on the tracks selected for recording, right up to the instant the track is put into Record. At the moment that the track(s) enter Record mode, the MX-80 switches the outputs of the tracks being recorded to Input monitor to allow you to listen to the new material as it is being recorded in sync with the material recorded earlier.

- (1) Rewind the tape to the beginning of the section to be overdubbed.
- (2) Set the ALL SAFE switch to the Ready position, and set the READY/SAFE switches for all the tracks that are not going to be recorded to Safe.
- (3) Set the READY/SAFE switches for the tracks that are going to be overdubbed to Ready. The READY LEDs for those tracks will be illuminated.
- (4) Press the ALL SEL-REP button. The SEL-REP LEDs for the tracks that are not being recorded will be illuminated. The INPUT LEDs for the tracks to be recorded will be illuminated if the STOP STANDBY switch is On.
- (5) Press the PLAY button to listen to the existing tracks. At the moment that the new material is to be inserted, press the RECORD button (or the PLAY and RECORD buttons, depending upon the setting of DSW1 on the Transport Control PCB) to begin the punch-in. Adjust the recording and monitor levels at the mixing console.
- (6) Press the PLAY (or RECORD and STOP buttons, depending on the setting of DSW1 on the Transport Control PCB) to punch-out (end the punch-in). The output signal for the tracks being overdubbed will return to Sel-Rep mode (e.g., being played back by the Record head), and the MX-80 will continue to play.
- (7) To hear the results of the punch-in, rewind the tape to the beginning of the section, set the ALL SAFE switch to the All Safe position. Press the Play button and adjust the monitor level at the console.

Repeat the punch-in until you are happy with the results.

OTARI's gapless punch-in provides the capability to insert new material onto a previously recorded track without a gap or overlap being recorded on the tape.

Actually producing perfect punch-ins requires patience and practice to achieve accurate results.

### 3.2.6 Rehearsing the Punch-In

To rehearse a punch-in without actually recording anything on the tape:

### Section 3

- (1) Rewind the tape to the beginning of the section to be overdubbed.
- (2) Press the REHEARSE button.
- (3) Set the ALL SAFE switch to the Ready position, and set the READY/SAFE switches for all channels which are not going to be recorded to safe.
- (4) Set the READY/SAFE switches for the channels that are going to be overdubbed to the Ready position. The READY LEDs for those channels will flash.
- (5) Press the ALL SEL-REP button. The SEL-REP LEDs for the tracks which are not being overdubbed will be illuminated. The INPUT LEDs for the channels which are being overdubbed will be illuminated if the STOP STANDBY switch is On.
- (6) Press the PLAY button to listen to the existing tracks. At the moment that the new recording is to begin, press the RECORD button (or the PLAY and RECORD buttons, depending upon the setting of DSW3 on the Transport Control PCB) to begin the Punch-in rehearsal.

#### 3.2.7 Bouncing or "Ping-Ponging" Tracks

Bouncing or "Ping-Ponging" tracks involves recording several original tracks, mixing those tracks and recording them back on to other tracks of the same tape, and then, adding more tracks to the mixed tracks. In order to maintain the highest signal quality during "ping-ponging", the recorded material should be played back from the Repro head. This means that the mixed tracks will not be in sync with the rest of the tracks. It is possible to bounce tracks using Sel-Rep playback from the Record head, but the quality will not be as good as it will be when using the Repro head. However, using Sel-Rep to bounce tracks leaves the resulting mixed track(s) in sync with the rest of the tracks. When bouncing tracks using Sel-Rep we recommend that you leave a blank (empty) track between the tracks being recorded and the tracks being mixed. For example, if you have already recorded on tracks 1 through 12, and wish to mix and bounce them to another track, it is advisable to record the mixed tracks on tracks 14 and 15, leaving track 13 empty as a guard track. You can then come back and record additional tracks in sync with the mixed material on tracks 14 and 15.



To "ping-pong" or bounce tracks:

- (1) Rewind the tape to the beginning of the section of tape to be mixed, and determine which tracks will be mixed and which tracks will be recorded onto.
- (2) Set the ALL SAFE switch to the Ready position.
- (3) Press the INDIVIDUAL button.
- (4) Set the individual INPUT/SEL-REP/REPRO switches to Repro for those tracks to be mixed, and to Input for those tracks to be recorded onto.

The mixing console controls should be set to mix the tracks that are in Repro and send the resulting mix to the tracks that are in Record Ready.

- (5) Press the RESET button to reset the Tape Timer so that Search Zero can be used to quickly return the tape to the beginning of the section.
- (6) Press the PLAY button, and adjust the mixing console for the desired mix of tracks and for a suitable recording level.
- (7) Press the SEARCH ZERO button to return the tape to the beginning.
- (8) When the desired mix has been achieved, begin recording by pressing the PLAY and RECORD buttons simultaneously.

The previously recorded tracks will be played by the Reproduce head, mixed together, and recorded on the tape at the Record head. You may now go back and record over (thereby erasing) the original tracks with new material in sync with the "ping-ponged" tracks, giving you the ability to record many more channels of material than the tape recorder has tracks.

### 3.2.8 Using the Spot Erase Feature

The Spot Erase feature utilizes time-ramp bias switching to enable you to erase small areas of the tape without leaving the usual assortment of clicks, pops, and chirps that are caused by short bias turn-on and turn-off times. To Spot Erase a small section of one track:



### Section 3

- (1) Mark the head (or beginning) and tail (or end) of the area to be erased using grease pencil or china marker. Position the tape so that the head mark is several inches to the left of the Erase head.
- (2) Set the ALL SAFE switch to the Ready position.
- (3) Set the READY/SAFE switches for the tracks to be erased to the Ready position.
- (4) Press the 2nd FUNCTION button and begin to move the tape toward the marked points, then press the RECORD button to enter Spot Erase mode without leaving a pop or thump recorded on the tape.
- (5) Move the tape by hand from the head mark to the tail mark. When the tail mark reaches the Erase head, release the RECORD button to terminate the function.

NOTE: Spot Erase feature can not be made through the Remote Control Unit, CB-123 and CB-124.

#### 3.2.9 Playing Back the Tracks for Mixdown

The basic tracks, overdubs, and punch-ins must all be played back into the mixing console to be combined and balanced for the final master tape. To play the tracks that have been recorded:

- (1) Rewind the tape to the beginning of the section of tape to be mixed.
- (2) Press the RESET button to reset the Tape Timer to 0.00.00.
- (3) Set the ALL SAFE switch to the All Safe position.
- (4) Press the ALL REPRO button.
- (5) Press the PLAY button to begin playback.
- (6) Adjust the level and balance of the individual tracks at the mixing console.
- (7) To return to the beginning of the tape for another pass, press the SEARCH ZERO button.

### 3.2.10 Library Winding the Tape

At the completion of a session the tape is generally stored "tails" out, for two good reasons, (1) to avoid audible "pre-echoes" resulting from tape print-through, and (2) to lessen the possibility of edge damage because the just played tape is wound much smoother than would result from fast winding the tape. The MX-80 includes a Spooling mode which provides a smooth Library Wind in only 1/4 the time required to play the tape onto the reel.

- (1) To Spool the tape onto the Take-up reel, press the F.FWD button, and then, keeping the F.FWD button pressed, press the 2nd FUNCTION.
- (2) To Spool the tape onto the Supply reel, press the REWIND button, and then, keeping the REWIND button pressed, press the 2nd FUNCTION.
- (3) To end the Spooling operation, press the STOP button.

### 3.2.11 Moving the Tape by Hand for Editing

The constant tape tension system used in the MX-80 allows the tape to be moved from one reel to the other by hand very easily. When the transport is in Stop mode, the tape lifters are retracted and the audio is not muted, making it possible to simply move the Tachometer Roller manually to locate the correct place on the tape.

To monitor the tape at the Repro head, press the ALL REPRO button, to monitor the tape at the Record head press the ALL SEL-REP button.

### 3.2.12 Editing the Tape

Often it is necessary to cut the tape to remove unwanted material. This involves selecting two points on the tape, separated by the segment to be removed, cutting the tape at those "edit points", removing the unwanted piece of tape, and rejoining the cut ends of the tape with adhesive splicing tape. The MX-80 Constant Tension System does not allow you to pull the tape away from the head assembly and cut it, as on some older machines, so the MX-80 features an Edit mode for releasing the reel brakes and dumping unwanted tape.

- (1) Press the ALL REPRO button, and wind the tape to the beginning of the section to be edited.

### Section 3

- (2) Press the STOP button, and move the tape by hand to locate the exact edit point at the head of the segment.
- (3) Mark the head edit point with grease pencil or china marker. Press one of the SEARCH 1 - 3 buttons to store this location.
- (4) Move the tape to the tail edit point, and carefully locate and mark the point.
- (5) Rewind the tape to the head edit point. If you stored the location using the SEARCH 1 - 3 button, press the SEARCH 1 - 3 button to quickly go to that point on the tape. Move the tape to place the head edit point between the Tach roller and the Take-up reel.
- (6) Press the EDIT/UNLOAD button and the PLAY button.
- (7) Allow the tape to "dump" to the tail edit point. When the tail edit point reaches the heads, stop the tape.
- (8) Pull the tape out away from the head assembly, and fit it into the Splicing Block. Position the tail edit point over the groove in the splicing block, and carefully cut the tape with a sharp blade.
- (9) Pull the head edit point from the Take-up reel to the splicing block, position it over the groove in the splicing block, and carefully cut the tape and join the ends with splicing tape.

**CAUTION:**

When in the Edit Play mode, direct the tape off the side of the transport with your hand to prevent the tape from being caught in the pinch roller.

#### 3.2.13 Using the Variable Speed Feature

The MX-80 allows you to change the speed of the tape, as it is being Recorded or Played, by  $\pm 50\%$  (about  $\pm$  two whole tones). This feature makes it possible to compress or extend material to fit it into a time slot, or to change the pitch for special effects, etc.

To manually adjust the speed of the MX-80:

- (1) Set the Speed Mode selector switch on the Remote Control Unit to the VARI position.



- (2) Use the PITCH CONTROL knob on the Remote Control Unit to vary the capstan speed as desired. Turning the PITCH CONTROL knob counterclockwise causes the speed to decrease, turning it clockwise causes the speed to increase.

#### 3.2.14 Controlling the Capstan Speed with an External Device

The capstan speed of the MX-80 can be controlled by an external device such as a resolver or synchronizer. The Parallel I/O connector on the rear panel provides an input for an External Speed Reference signal. This signal should be a square wave, TTL level (+5 V when on, 0 V when off), or a sine wave of 10 V peak to peak from a generator having a source impedance of less than 50 ohm at 9600 Hz for nominal speed. Refer to Table 6-4 for Parallel I/O connector pin assignments and signal descriptions.

To use an external speed reference signal connected to the Parallel I/O connector, set the Speed Mode Selector switch on the Remote Control Unit to EXT position. If the External Reference signal is lost, or falls below 6 V (sine wave signal) the machine will revert to its Fix speed mode.

The range of speed control possible from the Parallel I/O connector is -50%, +100% at 15 ips and +40, -50% at 30 ips.

#### 3.2.15 Changing the Machine Speed Pairs

The MX-80 is a three speed machine with two of the speed available for selection at the SPEED switch on the transport. Changing the speed pair involves changing one switch on the Capstan Control PCB and changing the equalization jumpers on each of the Audio Amplifier PCBs.

- (1) Open the upper rear panel by removing the 2 upper screws on each side of the panel, and allowing it to fold down to horizontal.
- (2) On the Transport Control PCB, change the setting of SW2. If your machine was initially configured for 15/30 ips, the switch will be in the H position, if initially configured for 7.5/15 ips, the switch will be in the L position. Set the switch to correspond to the desired speed pair (H or L).
- (3) Perform the Routine Audio Alignment procedures described in Section 4.2.



### Section 3

- (4) Perform the Routine Transport Alignment procedures described in Section 4.1.
- (5) Close the upper rear panel and replace the 4 screws removed in Step 1.

## SECTION 4: ALIGNMENT AND CALIBRATION

This section contains the instructions and information required to perform the routine reel control, tape tension, head alignment, audio channel calibration, bias and erase adjustments associated with normal maintenance of the MX-80.

When you are performing these procedures for the first few times, proceed slowly and carefully. Soon you will be familiar with them, but initially it is better to be cautious and avoid accidents.

### 4.1 TRANSPORT ALIGNMENT

The MX-80 transport should not require frequent adjustment of tape tension and wind speeds, but these procedures should be performed whenever track format or tape width is changed, or if any mechanical component in the tape path has been replaced.

#### 4.1.1 Tools and Equipment Required

- (1) DC voltmeter capable of 0.05 V resolution while measuring  $\pm 5$  V.
- (2) Frequency counter capable of 50 Hz resolution while measuring 9.6 kHz.
- (3) A general purpose dual-trace oscilloscope such as those made by Tektronics, Leader, Hitachi, Hewlett-Packard, etc. The oscilloscope is necessary for Tacho quadrature, and Capstan duty cycle adjustments.
- (4) A Wow and Flutter meter capable of 0.01% resolution, DIN 45504 weighted.
- (5) A reel of tape of the type normally used for sessions.
- (6) A small non-magnetic alignment screwdriver with a blade small enough to fit the trimmers on the Reel and Transport Control PCBs.
- (7) 1.5 mm, 2 mm, 2.5 mm, and 4 mm hex keys (allen wrenches).
- (8) A calibrated, direct reading tape tension meter such as Tentelometer Model T2-H20-2.

## Section 4

### 4.1.2 Opening the Transport and Removing the Deck Skin Panels

- (1) Turn Off the Power to the machine and wait 30 seconds to allow the power supply capacitors to discharge, Remove any tape and/or empty reels from the transport.
- (2) Open the upper rear panel to gain access to the Reel Control PCB by removing the uppermost two screws on each side of the panel, and folding it down to a horizontal position.

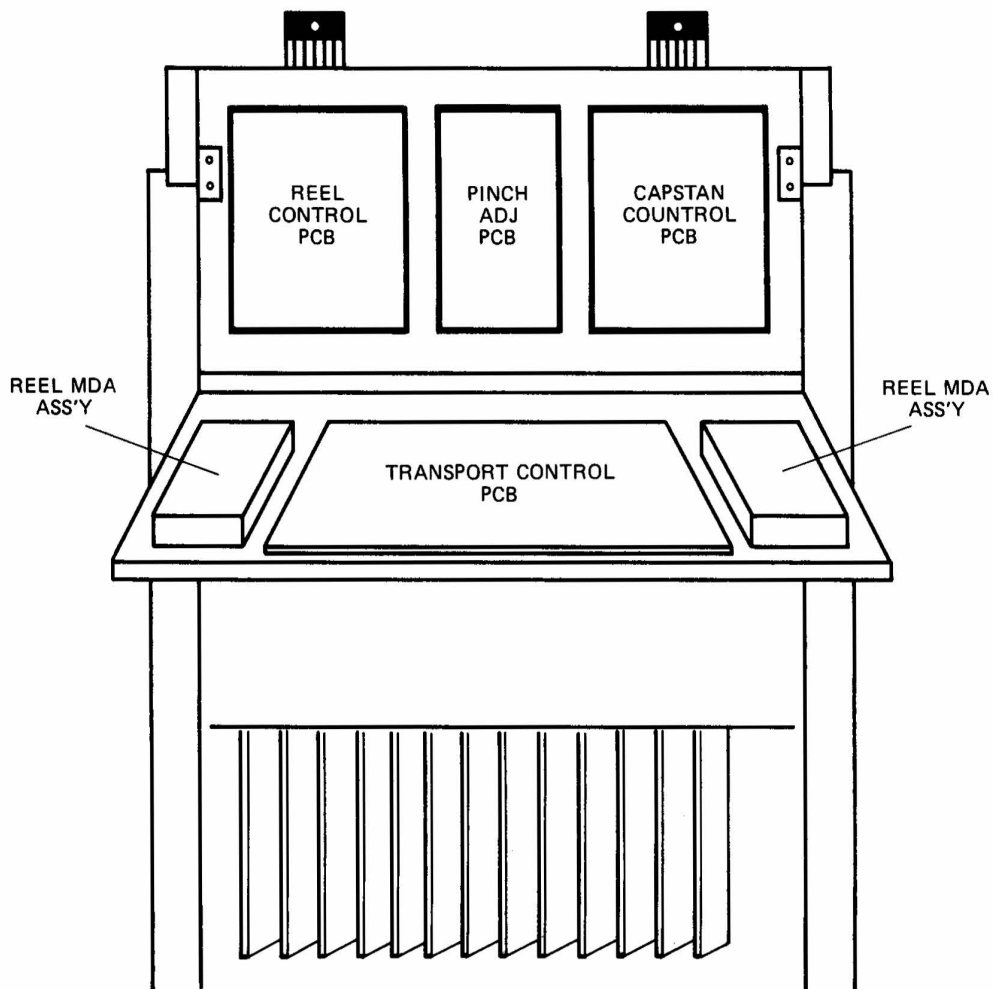

Figure 4-1 Location of Transport, Capstan, and Reel Control PCBs

- (3) Open the VU Meter panel by removing the outer two screws from the top of the panel, and folding it down to a horizontal position.
- (4) Remove the Splicing Block by removing the four socket head screws which attach it to the transport deck top.
- (5) Loosen the Capstan Shaft Dust Cap by turning it counterclockwise.
- (6) Remove the four socket head screws which attach the front Deck Skin Panel, and while holding the Tension Arm Rollers at their uppermost position, carefully remove the front Deck Skin Panel.

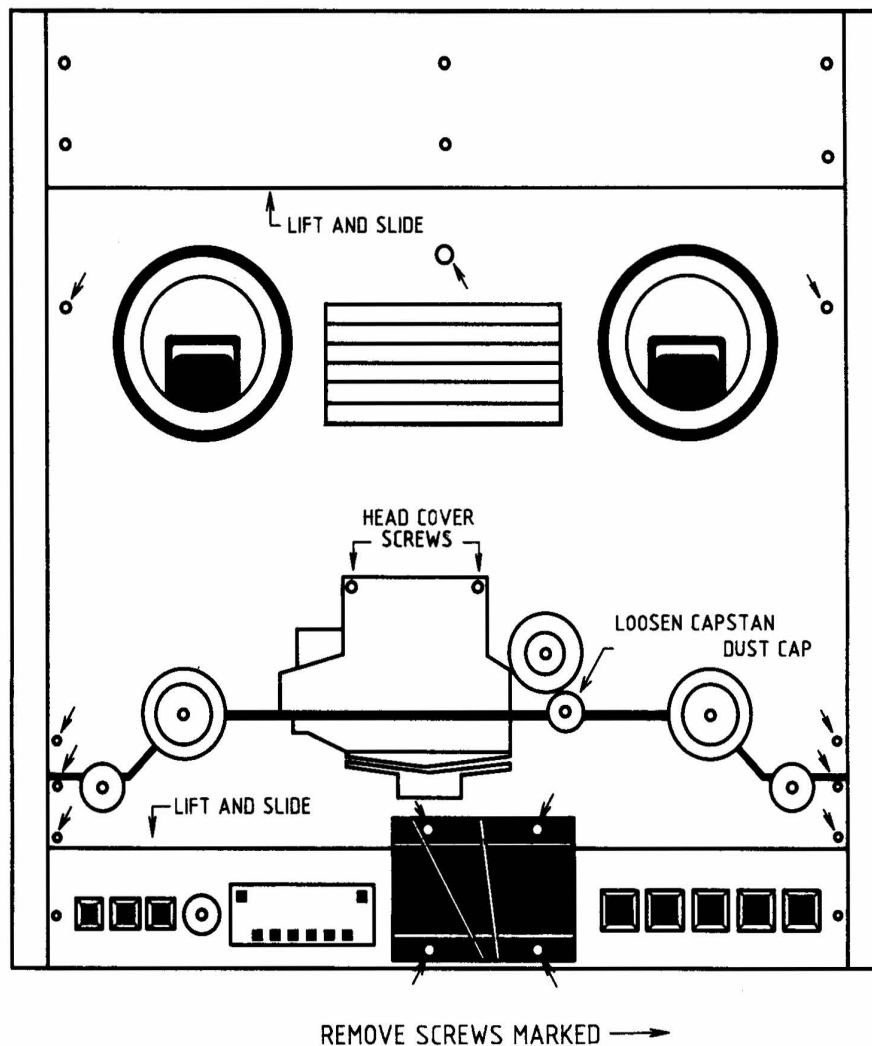

Figure 4-2 Deck Skin Panel removal



## Section 4

- (7) Remove the Pinch Roller assembly from its shaft by removing the socket head screw in the center of the top of the Roller assembly and lifting the Pinch Roller assembly off its shaft.
- (8) Remove the Head Assembly Cover by removing the two socket head cap screws which attach it to the Transport Deck, and lifting the Head Assembly Cover off the machine.
- (9) Remove the rear Deck Skin Panel by first removing the five socket head screws from the perimeter of the rear Deck Skin. Then lift the rear of the Panel and carefully slide it toward the rear of the machine until it can be lifted off the machine.

### 4.1.3 Reel Tension Servo Adjustment

The constant tape tension system employed on the MX-80 utilizes Tension Arms in the tape path to provide feedback information to the Reel Control PCB. These circuits adjust the torque and speed of the Take-up and Supply reel motors to keep the tension on the tape constant regardless of operating mode, tape speed, and amount of tape on the reels.

#### 4.1.3.1 Tension Arm Spring Tension Adjustment

The running tape tension is set by the balance of Reel Motor torque against the tension of the Tension Arm springs. Therefore it is important that the Tension Arm Spring Tension be set accurately.

- (1) Attach the 0 - 2000 gram spring scale to the Tension Arm Roller with a loop of string.
- (2) Pull the spring scale toward the rear of the machine until the Tension Arm is in the middle of its travel, and measure the spring tension. Refer to Figure 4-3.
- (3) If the spring tension is not 500 grams  $\pm$  10%, then loosen the lock nut on the Spring Adjusting Screw by holding the portion closest to the Anchor Bracket and unscrewing the outer portion. Adjust the inner nut as necessary to obtain 500 grams  $\pm$  10% tension reading on the spring scale. It is good practice to adjust both Supply and Take Up Tension Arms to the same tension within  $\pm$  10 grams.
- (4) Tighten the outer portion of the double nut to lock the adjusting screw in place.

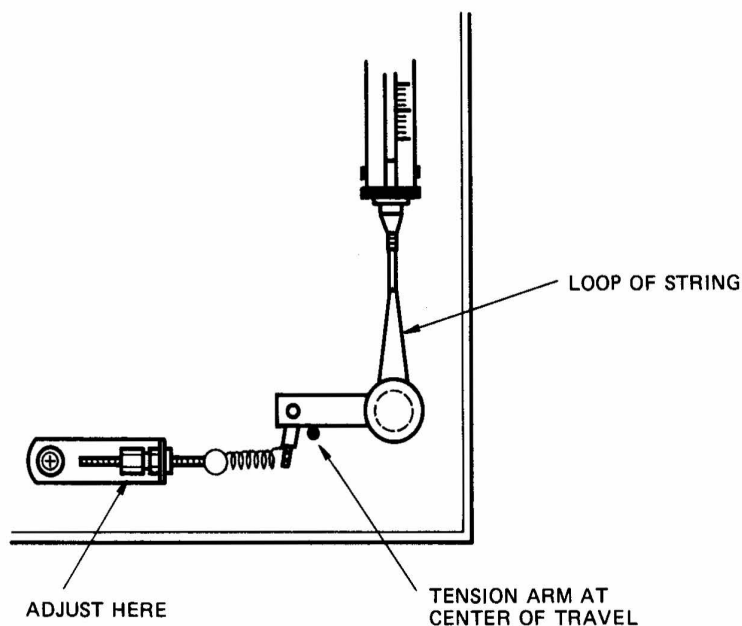

Figure 4-3 Tension Arm Spring Tension Measurement

#### 4.1.3.2 Tachometer Quadrature/Phase Adjustment

- (1) Connect CH1 of the dual channel oscilloscope to TP2 on the Transport Control PCB.
- (2) Connect CH2 of the oscilloscope to TP3. Use TP1 for Ground for the oscilloscope.
- (3) Connect the Tach Roller to the Capstan Shaft with a rubber band, so that the Tach Roller turns when the Capstan Shaft turns.
- (4) Secure both Tension Arms at the top of their travel.
- (5) Adjust the position of the Tacho II PCB (the PCB with two sensors) so the waveform at TP3 leads the waveform at TP2 by 90 degrees.

NOTE: The waveforms do not have 50% duty cycle. Refer to Figure 4-5. Remove the rubber band when adjustment is completed.

Section 4

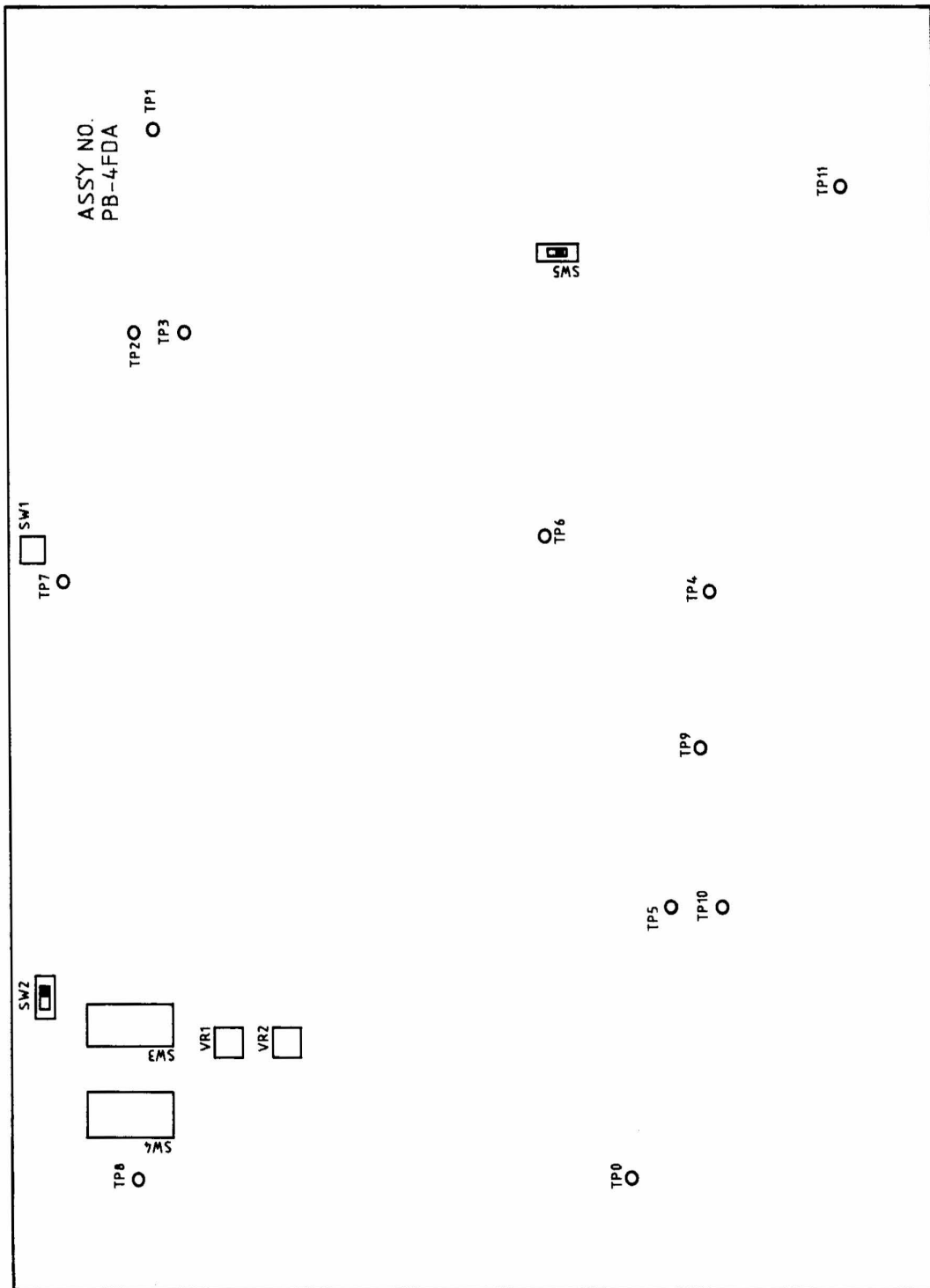

Figure 4-4 Location of Trimmers and Check Points on Transport Control PCB

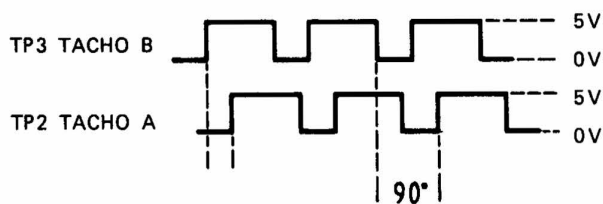

Figure 4-5 Tach Waveforms

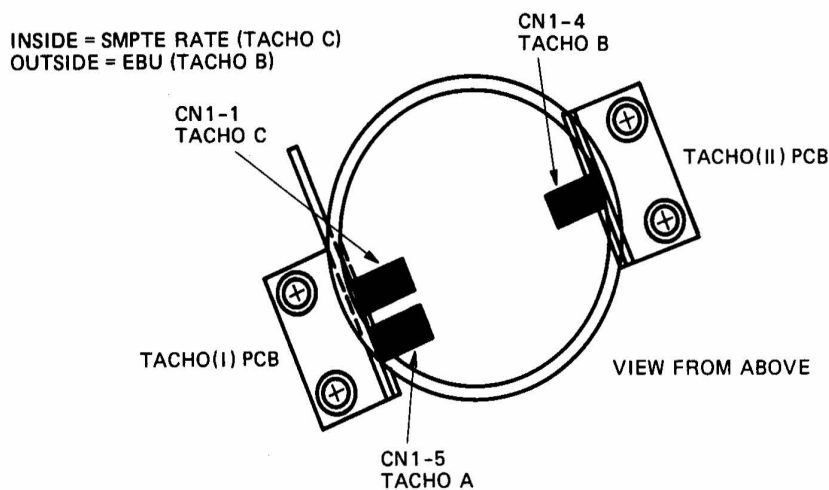

Figure 4-6 Location of Tacho I and Tacho II PCBs

#### 4.1.3.3 Fast Wind Speed Reference Voltage Adjustment

- (1) Adjust VR2 for 0.0 V at TP5 on the Transport Control PCB in Unload mode.
- (2) Secure both Tension Arms at the top of their travel.
- (3) Adjust VR1 for 7.0 V at TP5 on the Transport Control PCB in Fast Forward mode.



## Section 4

### 4.1.3.4 Tension Sensor Position

- (1) Remove and Tape and Reels from the Transport, and raise the Transport to its open position (Refer to Section 4.1.6). Turn On the Power to the machine.
- (2) With the Supply Tension Arm at the bottom of its travel, adjust the position of the Safety Sensor so that its centerline is aligned with the center of the Tension Arm Shaft.
- (3) With the Supply Tension Arm at the bottom of its travel, adjust the position of the Sensor Vane, by loosening the two screws which attach the Vane to the mounting collar, so that the edge of the vane lines up with the edge of the Safety Sensor. Tighten the Vane mounting screws.
- (4) Adjust the position of the Supply Tension Sensor so that its centerline is aligned with the center of the "C" screw. Tighten its mounting screw securely.

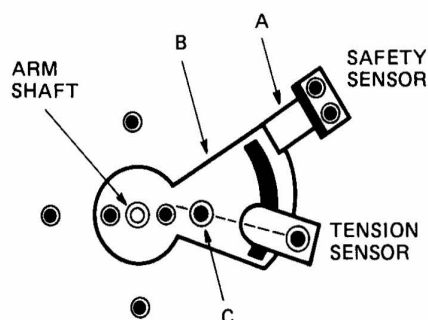

Figure 4-7 Location of Tension Sensor Adjustments

- (5) Connect the DC Voltmeter to CP1 (Supply) and CP11 (Ground) on the Reel Control PCB.
- (6) Slowly move the Supply Tension Arm from the bottom to the top of its travel while observing the voltage on the DC Voltmeter. The voltage will decrease as the Tension Arm is raised. If the voltage reaches its minimum before the Tension Arm reaches its upper limit, then the Tension Sensor position must be adjusted. Repeat the observation and adjustment until the Sensor Voltage is linear with Tension Arm travel. Refer to Figure 4-9.

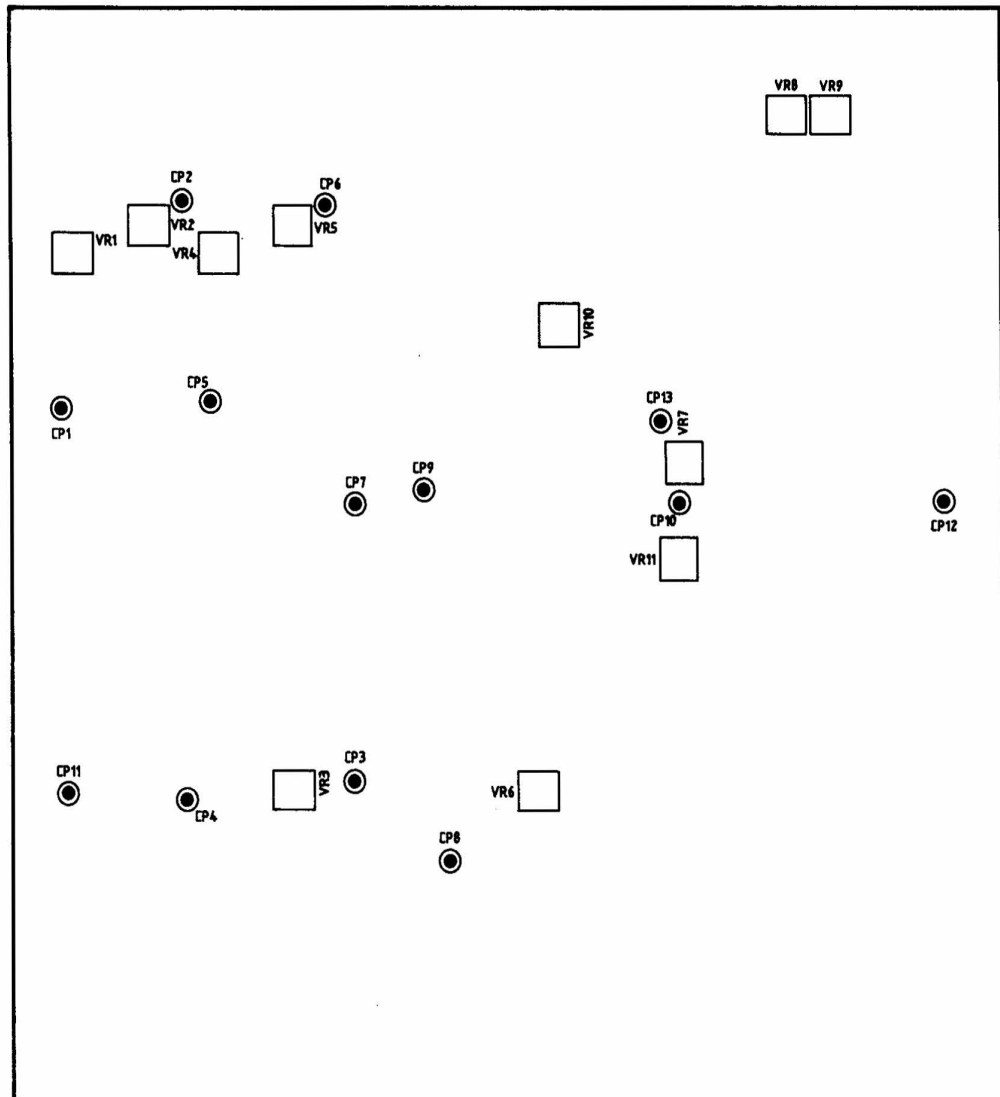

Figure 4-8 Location of Trimmers and Check Points on Reel Control PCB

## Section 4

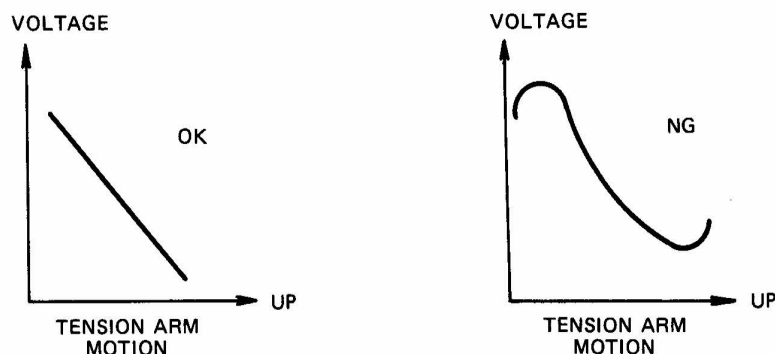

Figure 4-9 Tension Sensor Voltage Adjustment

- (7) Repeat Steps 1 through 6 for the Take Up Tension Arm Sensor assembly using CP 5 on the Reel Control PCB.

### 4.1.3.5 Tension Arm Sensor Gain Adjustment

- (1) Hold the Take Up Tension Arm at the top of its travel and adjust VR4 on the Reel Control PCB for 0.0 V at CP6.
- (2) Let the Take Up Tension Arm return to the bottom of its travel and adjust VR5 for 10.0 V at CP6.
- (3) Hold the Supply Tension Arm at the top of its travel and adjust VR1 for 0.0 V at CP2.
- (4) Let the Supply Tension Arm return to the bottom of its travel and adjust VR2 for 10.0 V at CP2.

### 4.1.3.6 Play Acceleration Preliminary Adjustment

- (1) Hold both Tension Arms at the top of their travel.
- (2) Adjust VR11 of the Reel Control PCB for 7.0 V at CP10 in Play mode.

NOTE: Adjust VR11 within the first two seconds after pressing the PLAY button because the voltage will decrease rapidly after a short time.

#### 4.1.3.7 Fast Forward and Rewind Torque Adjustment

- (1) Remove Tape and Reels from the Transport and secure both Tension Arms at the top of their travel.
- (2) Connect the DC Voltmeter to the top of R27 (or IC4 Pin 1) on the Reel Control PCB, and place the MX-80 in Rewind mode.
- (3) After about 10 seconds (after the voltage has stabilized), adjust VR8 to obtain a reading of  $-9.0 \text{ V} \pm 0.5/-0.25 \text{ V}$  on the DC Voltmeter. Press the STOP button.
- (4) Connect the DC Voltmeter to the top of R71 (or IC10 Pin 1), and place the MX-80 in Fast Forward mode.
- (5) After about 10 seconds (after the voltage has stabilized), adjust VR9 to obtain a reading of  $-9.0 \text{ V} \pm 0.5/-0.25 \text{ V}$  on the DC Voltmeter. Press the STOP button.

#### 4.1.3.8 Reel Motor Torque Adjustment

- (1) Secure both Tension Arms at the top of their travel.
- (2) Connect the DC Voltmeter to CP4 on the Reel Control PCB.
- (3) Hold the Supply reel firmly by hand to prevent it from turning, and place the MX-80 in Rewind.
- (4) After about 10 seconds (after the voltage has stabilized), adjust VR 3 to obtain a reading of  $+ 7.5 \text{ V} \pm 0.5 \text{ V}$  on the DC Voltmeter. Press the STOP button.
- (5) Connect the DC Voltmeter to CP8.
- (6) Hold the Take Up reel firmly by hand to prevent it from turning, and place the MX-80 in Fast Forward.
- (7) After about 10 seconds (after the voltage has stabilized), adjust VR 6 to obtain a reading of  $+ 7.5 \text{ V} \pm 0.5 \text{ V}$  on the DC Voltmeter. Press the STOP button.

#### 4.1.3.9 Tension Arm Position Adjustment

- (1) Thread the machine with tape and wind until there is an equal amount of tape on each reel.



## Section 4

- (2) Adjust VR4 on the Reel Control PCB until the front edge of the Take Up Tension Arm is even with the drill mark in the deck plate, while in Load mode. Refer to Figure 4-10.
- (3) Place the machine in Play briefly to confirm the position of the Tension Arm.

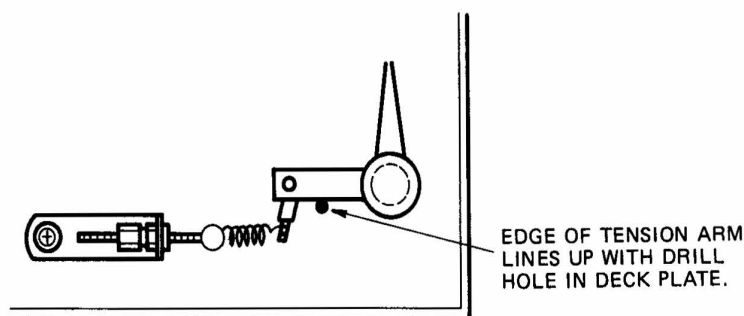

Figure 4-10 Tension Arm Position Adjustment

- (4) Adjust VR1 until the front edge of the Supply Tension Arm is even with the drill mark in the deck plate, while in Load mode.
- (5) Place the machine in Play briefly to confirm the position of the Tension Arm.

### 4.1.3.10 Fast Wind and Spooling Wind Speed Adjustment

- (1) Connect the Frequency Counter to CP13 on the Reel Control PCB.
- (2) Thread the machine with tape and wind until there is an equal amount of tape on each reel.
- (3) Place the machine in Fast Forward mode.
- (4) After the frequency has reached its maximum (about 10 seconds), adjust VR 10 to obtain a frequency reading of  $3000 \text{ Hz} \pm 30 \text{ Hz}$ .
- (5) Rewind the tape until there is an equal amount on each reel.

- (6) Place the machine in Forward Spooling Wind mode (by pressing 2nd FUNCTION and F.FWD buttons).
- (7) Readjust VR7 to obtain a frequency reading of 1000 Hz  $\pm$  10 Hz.
- (8) Place the machine in Fast Forward mode and note the frequency reading.
- (9) Place the machine in Rewind and note the frequency reading. If the Fast Forward and Rewind readings are not within 60 Hz of each other adjust VR3 and VR6 until they are.

#### 4.1.3.11 Tape Tension Check

Thread the machine with tape and wind until there is an equal amount of tape on each reel. With the MX-80 in Stop mode, measure the tape tension between the Take Up Tension Arm Roller and the Take Up Reel, using a calibrated Tentelometer (or equivalent). The tape tension should be 320 grams  $\pm$  20 grams. If the tape tension is not correct, check the tension of the Tension Arm springs (Section 4.1.3.1), and check the setting of the Tension Arm position trimmers VR1(Supply) and VR4 (Take Up). Refer to Section 4.1.3.9.

#### 4.1.4 Capstan Servo Adjustment

Refer to Figure 4-1 for the location of the Capstan Control PCB. If you have just completed adjustments to the Reel Control PCB, the necessary panels will already be open, and you may disregard any instruction relating to opening the panels to gain access to the PCBs. These procedures should be performed in the order presented here because the correct adjustment of one parameter may depend upon the previous correct adjustment of another parameter.

##### 4.1.4.1 Preliminary Adjustment

- (1) Turn Off the Power to the machine and wait 30 seconds to allow the power supply capacitors to discharge. Remove any tape and/or empty reels from the transport.
- (2) Open the upper rear panel to gain access to the Capstan Control PCB by removing the uppermost two screws on each side of the panel, and folding it down to a horizontal position.

Section 4

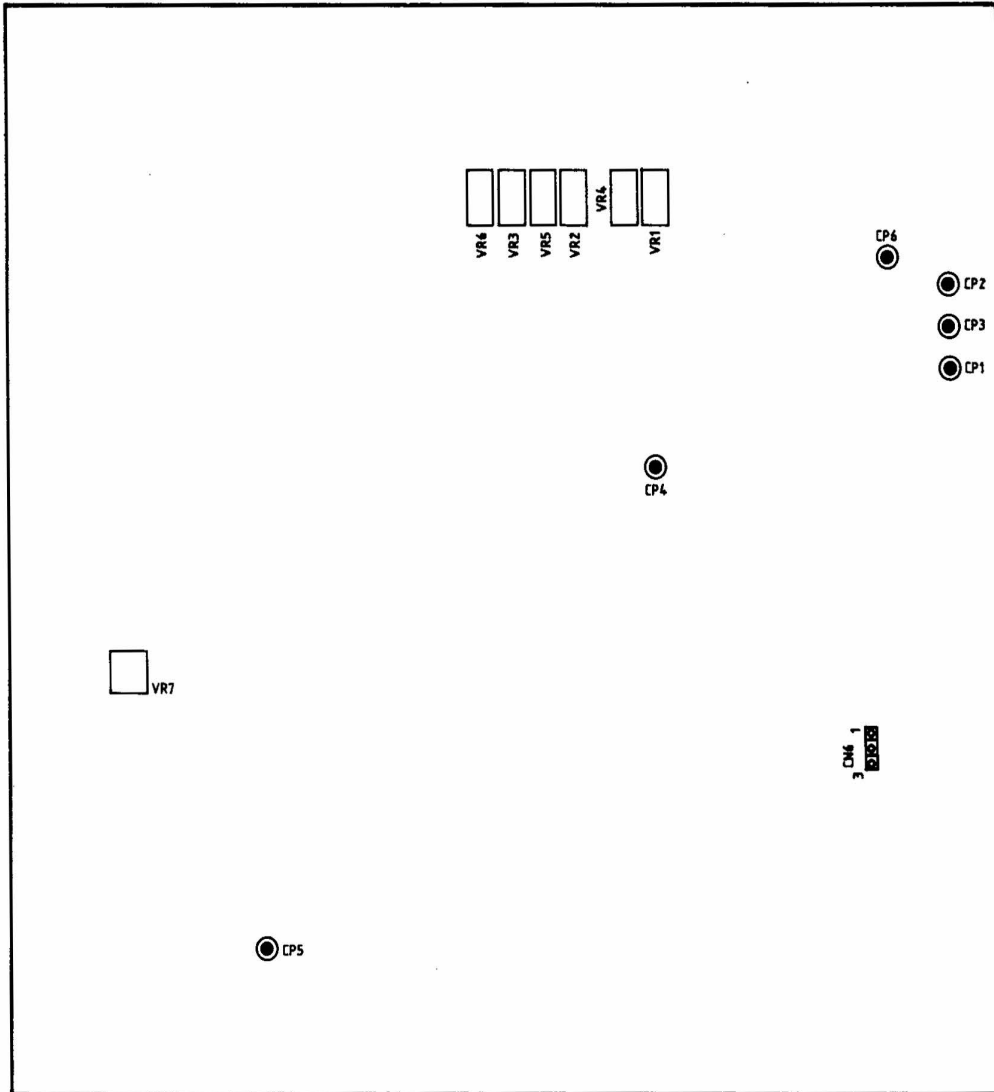

Figure 4-11 Location of Trimmers and Test Points on Capstan Control PCB

- (3) On the Capstan Control PCB, turn VR1, VR2, VR3, VR4, VR5, and VR6 fully counterclockwise until the trimpot clicks on each revolution (NOTE: These are 30-turn trimpots), then turn each trimmer clockwise 15 full revolutions.
- (4) Set VR7 on the Capstan Control PCB to the center of its rotation.

#### 4.1.4.2 Phase Locked Loop Duty Cycle Adjustment

- (1) Connect an oscilloscope to CP3 and Ground on the Capstan Control PCB.
- (2) Set the SPEED switch on the Transport Control Panel to the H position. Set SW2 on the Transport Control PCB (the H/L Speed Pair switch) to the H position. Set the SPEED MODE switch on the Remote Control unit to the Fix position.
- (3) Secure both Tension Arms at the top of their travel.
- (4) Turn On the Power to the MX-80.



Figure 4-12 Capstan Waveforms

- (5) Adjust VR7 so that the waveform displayed on the oscilloscope has a duty cycle of approximately 50%.

#### 4.1.4.3 Gain Adjustment

- (1) With the oscilloscope still connected to CP3 on the Capstan Control PCB and the SPEED switch still set for 30 ips, adjust VR4 (30 ips Gain) so that the waveform displayed on the oscilloscope has a duty cycle of exactly 50%.



## Section 4

- (2) Set the SPEED switch on the Transport Control Panel to the L position (15 ips).
- (3) Adjust VR5 (15 ips Gain) so that the waveform displayed on the oscilloscope has a duty cycle of exactly 50%.
- (4) Set SW2 on the Transport Control PCB (the H/L Speed Pair switch) to the L position.
- (5) Adjust VR6 (7.5 ips Gain) so that the waveform displayed on the oscilloscope has a duty cycle of exactly 50%.

### 4.1.4.4 Capstan Servo Damping Adjustment

NOTE: If a Wow and Flutter meter is not available, do not change the setting of VR1, VR2, or VR3 (Capstan Damping trimmers).

- (1) Thread the MX-80 with tape and wind until there is less than 1/2" (1.25 cm) of tape pack remaining on the Supply Reel.
- (2) Connect the (3150 Hz) output of the Wow and Flutter meter to the TEST SIGNAL input on the Audio Control PCB.
- (3) Connect the input of the Wow and Flutter meter to the CH8 rear panel Line Output connector.
- (4) Set SW2 on the Transport Control PCB (the H/L Speed Pair switch) to the H position. Set the SPEED switch on the Transport Control Panel to the H position (30 ips).
- (5) Set the CH8 READY/SAFE switch on the Remote Control unit to the Ready position. Set the ALL SAFE switch to the Ready position.
- (6) Press the ALL REPRO button on the Remote Control unit, and press the RECORD and PLAY buttons to place the machine in Record mode.
- (7) Adjust VR1 a small amount (one or two revolutions) and observe the Wow and Flutter meter. If a change in Wow and Flutter performance is observed, continue adjusting VR1 until the best performance is observed. If no change is observed in the first one or two revolutions of the trimmer, return the trimmer to its initial position and continue with the next step.
- (8) Set the SPEED switch on the Transport Control Panel to the L position (15 ips).

- (9) Place the machine in Record mode, and repeat step 7 using VR2 for adjustment.
- (10) Set SW2 on the Transport Control PCB (the H/L Speed Pair switch) to the L position.
- (11) Place the machine in Record mode, and repeat step 7 using VR3 for adjustment.

The capstan motor should lock (as indicated by the bi-color LED on the Capstan Control PCB changing from Red to Green) quickly and smoothly when the Capstan Motor speed or direction is changed.

#### 4.1.5 Pinch Roller Timing

Switch SW1 on the Pinch Roller PCB adjusts the delay time between pressing the PLAY button and the Pinch Roller pulling in against the Capstan Shaft. These switches have been preset at the OTARI factory and do not require adjustment.

#### 4.1.6 Tape Lifter Adjustment

Adjustment of the Tape Lifter position should not be necessary unless a Tape Lifter is changed or a Head is replaced

- (1) Turn Off the Power to the machine and wait 30 seconds to allow the power supply capacitors to discharge. Remove any tape and/or empty reels from the transport.
- (2) Open the VU Meter panel by removing the outer two screws from the top of the panel, and folding it down to a horizontal position.
- (3) Cut a piece of recording tape approximately 10 ft (3 meters) long, and thread it on the machine, wrapping it around the Reel Tables by hand to hold it in position across the heads.

NOTE: This is necessary because the Tape Lifter adjustment must be made with tape on the machine, but the Transport cannot be opened while Reels are on the Reel Tables.

- (4) Remove the 4.5 mm socket head cap screw from the underside of each side of the Transport Deck Plate, and carefully lift the Transport Deck Plate until it latches in the open position.

Section 4

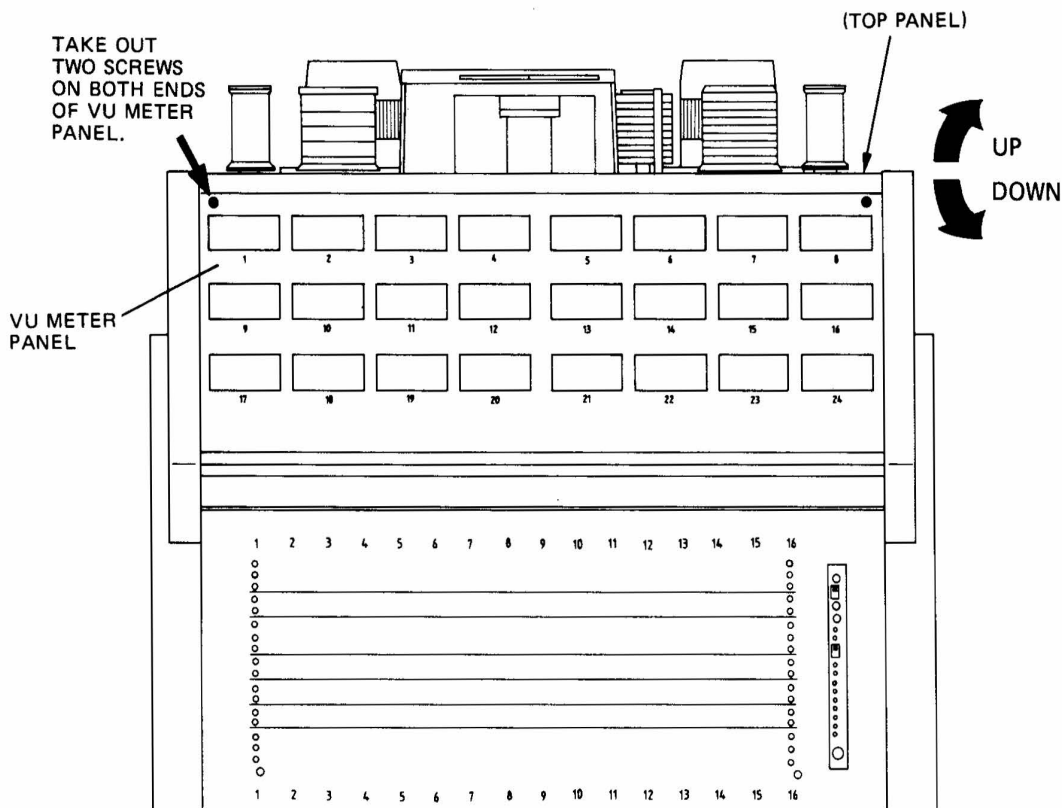

Figure 4-13 Opening the Transport

- (5) Loosen the four screws which attach the Lifter Solenoid to the Deck Plate, and move the Lifter Solenoid as far toward the left side of the machine as it will go. Refer to Figure 4-14.
- (6) Push the right Tape Lifter toward the front of the machine, and adjust Stopper A so that the right Tape Lifter (between the Repro Head and the Flutter Filter Roller) moves the tape 0.5 mm (0.02 in) away from the Repro Head.

NOTE: Be sure that the Tape Lifter Arm does not hit the Head Shield Plate, when the Shield Plate is in its retracted position.

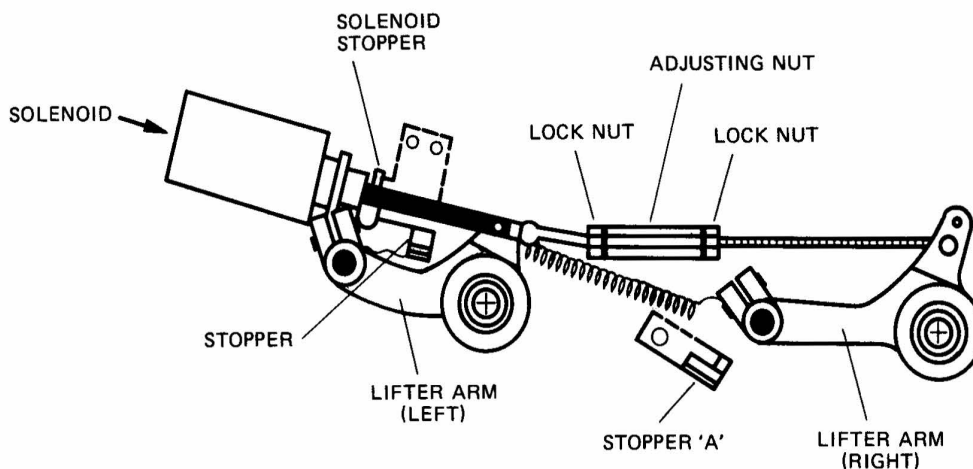

Figure 4-14 Tape Lifter Adjustments

- (7) Hold the right Tape Lifter so that it is extended fully (against Stopper A), and adjust the threaded standoff so the left Tape Lifter (between the left Tape Guide and the Impedance Roller) holds the tape 0.5 mm (0.02 in) away from the Record Head.

## NOTES:

- a) The lock-nuts at each end of the standoff must be loosened before adjusting the standoff.
  - b) Turn the standoff clockwise to decrease the clearance between the tape and the Record Head.
  - c) If the standoff is turned too far counterclockwise, the left Tape Lifter will hit the Deck Plate when extended, and the right Tape Lifter will not be able to be adjusted properly.
- (8) Tighten the locknuts on each end of the standoff when adjustment is correct.
- (9) Push the Lifter Solenoid plunger into the solenoid body, and adjust the position of the solenoid until the left Tape Lifter holds the tape 0.5 mm from the Record Head when it is extended. Tighten the screws to hold the solenoid in position.
- (10) Secure both Tension Arms at the top of their travel.



## Section 4

- (11) Set Switch 3-3 on the Transport Control PCB to the On position.
- (12) Apply Power to the MX-80. Press the STOP button to place the Transport in Load mode. Press the CUE button to cause the Tape Lifters to be extended.
- (13) Carefully check the position of the Tape Lifters. If the tape is not 0.5 mm from the Repro and Record Heads, repeat the adjustment procedure.
- (14) Press the CUE button to retract the Tape Lifters, and check to see that the left Tape Lifter is approximately 1 mm behind the tape. If it is not, adjust the position of Stopper B until the retracted position is correct.
- (15) Adjust the position of the Solenoid Plunger Stopper so that the solenoid plunger contacts it at the same time that the left Tape Lifter Arm contacts Stopper B.

### 4.1.7 Pinch Roller Position and Pressure Adjustment

- (1) Adjust the position (from beneath the Transport Deck Plate) of the Solenoid Stopper so the Pinch Roller is 4 - 5 mm from the Capstan Shaft when it is its disengaged position.

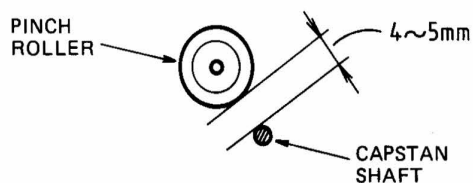

Figure 4-15 Pinch Roller Pressure Measurement

- (2) Secure both Tension Arms at the top of their travel.
- (3) Attach the 0 - 4000 gram spring scale to the Pinch Roller with a loop of string.
- (4) Place the MX-80 in Play mode.

- (5) Pull the spring scale toward the rear of the machine until the Pinch Roller just loses contact with the Capstan Shaft (and stops turning), and measure the Pinch Roller pressure.
- (6) If the Pinch Roller pressure is not 2500 grams  $\pm$  300 grams, adjust the position of the Pinch Roller solenoid slightly and repeat the measurement.

#### 4.1.8 Brake Adjustment

Some of these adjustments can be performed with the Reel Motor Assembly installed in the MX-80, or with the Reel Motor Assembly on the work bench. If the adjustments are performed at the bench, the final adjustments for tension must be made after the Assembly is re-installed in the MX-80.

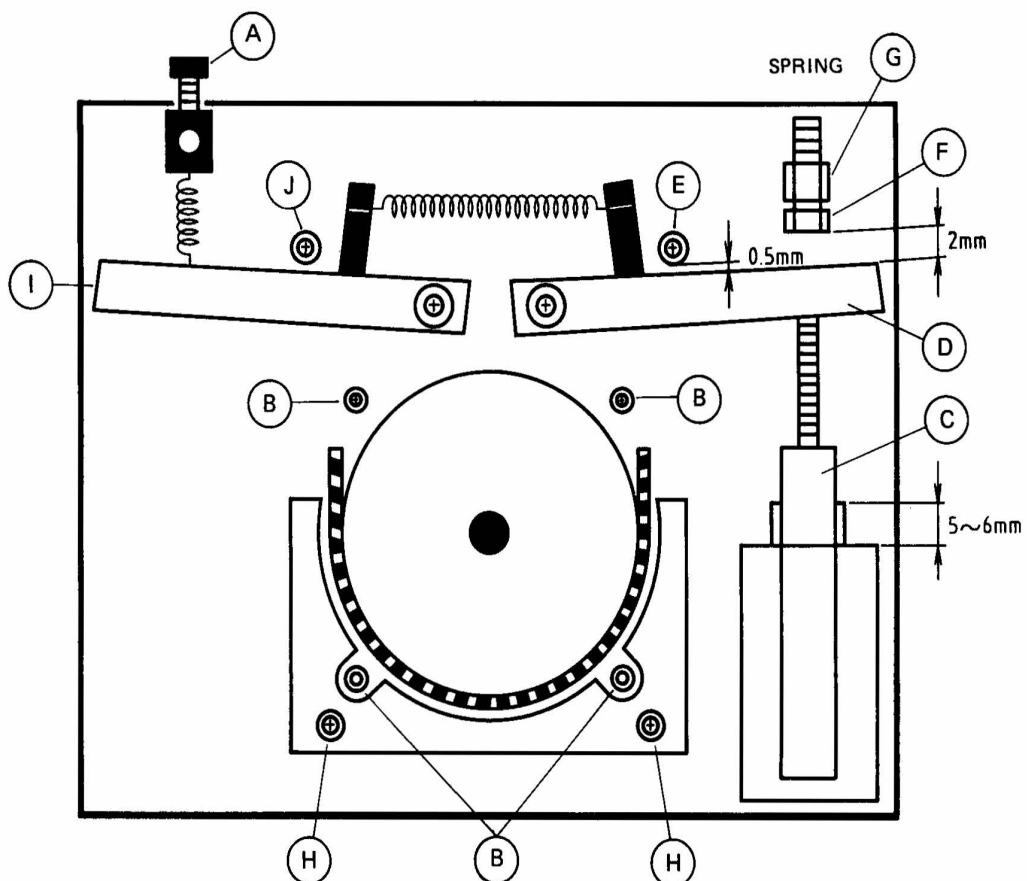

Figure 4-16 Brake Adjustments

## Section 4

- (1) Loosen the screws marked "B" in Figure 4-16 and adjust the Brake Assembly on the motor so that there is 0.5 mm clearance between arm "D" and post "E". Securely tighten the screws.
- (2) Adjust the double-nut "F" so that 5-6 mm of plunger body protrudes from the solenoid body, while pushing in on "G" to remove any slack in the linkage.
- (3) Adjust bracket "C" for 1 mm clearance between the fiber washer "F" and the arm "D" while pulling out on "G" to remove any slack in the linkage.
- (4) Loosen the screws marked "H" and adjust the guide so that the band does not rub on the brake drum when the solenoid is energized (push "G" all the way in to check).
- (5) Check the Holdback tension by winding the free end of a piece of string or twine around an NAB reel hub (clockwise for the Supply reel, counterclockwise for the Take-up reel), and pulling on the string with a spring scale to unwind the string. Since the reading on the spring scale is dependent on the speed at which the string is pulled, it is recommended that two or three readings be made and the results averaged.
- (6) If the tension is not approximately 1200 - 1500 grams, loosen the tension bracket locking screw and adjust the screw marked "A" so that the tension in the "holdback" direction is within that range.

NOTE: Adjust the brake tension so that both Take-up and Supply sides show the same tension  $\pm$  100 grams in the "holdback" direction.

- (7) Check the feed tension by repeating the above procedure with the string wound on the hub in the opposite direction.

The brake tension in the feed direction is not separately adjustable, and should be approximately one-half of the value measured in the "holdback" direction (i.e., 600 - 750 grams).

If correct holdback tension cannot be obtained after replacing Brake Bands, it may be necessary to rotate the drum against the brake band to "wear in" the brake bands.

## 4.2 ROUTINE AUDIO ALIGNMENT

### 4.2.1 Tools, Materials, and Test Equipment Required

| Speed   | EQ  | Ref. Flux | MRL Cat. No. |
|---------|-----|-----------|--------------|
| 30 ips  | AES | 250 nWb/m | 51L214       |
| 15 ips  | NAB | 250 nWb/m | 51J213       |
| 7.5 ips | NAB | 250 nWb/m | 51T212       |
| 15 ips  | IEC | 320 nWb/m | 51J323       |
| 15 ips  | IEC | 250 nWb/m | 51J223       |
| 7.5 ips | IEC | 320 nWb/m | 51T322       |
| 7.5 ips | IEC | 250 nWb/m | 51T222       |

NOTE: Standard equalization for 2" 24 track machines at 15 and 7.5 ips is NAB. Standard equalization for 2" 32 track machines at 15 and 7.5 ips is IEC. Standard equalization at 30 ips is AES for all track formats.

### 4.2.2 Demagnetizing the Heads and Tape Path

Demagnetizing (sometimes called degaussing, although that term is more often applied to bulk tape erasure) is a necessary procedure, and should be performed prior to every alignment and before every recording session. Demagnetizing should always be done with extreme caution:

#### DEMAGNETIZING CAUTION:

To avoid damage to the MX-80, always make sure the POWER switch is Off before proceeding. Make sure that all recording tapes, especially alignment tapes, are removed from the vicinity of the MX-80. The AC field created by the demagnetizer is extremely powerful and could seriously damage the electronics if they are On.

Never turn On or Off the power to the demagnetizer unless it is at least 3 feet (1 meter) away from the MX-80. This would cause an extremely strong moving magnetic field which could possibly place a permanent magnetic charge on parts of the machine. The demagnetizer would not be powerful enough to remove these charges under normal circumstances, and the parts might have to be removed and discarded. USE ONLY A



#### Section 4

DEMAGNETIZER WITH HIGH FLUX DENSITY, INEXPENSIVE "HI-FI" TYPE DEMAGNETIZERS CAN LEAVE RESIDUAL FIELDS THAT WILL CAUSE MORE HARM THAN BENEFIT.

- (1) Turn off the MX-80 POWER switch.
- (2) With the demagnetizer at least 3 feet (1 meter) from the MX-80, plug the demagnetizer into the AC mains and turn it on.
- (3) Slowly move the demagnetizer toward the supply swing arm roller until the tip is approximately 1/8" (3 mm) away from the roller.
- (4) Slowly move the tip of the demagnetizer up and down along the roller so that the entire roller surface is exposed to the demagnetizing field. DO NOT TOUCH ANY PART OF THE MX-80 WITH THE DEMAGNETIZER.
- (5) Slowly move the demagnetizer at least 3 feet (1 meter) away from the MX-80.
- (6) Working from left to right repeat Steps 3, 4, and 5 for each of the following metal parts in the tape path:
  - A. Tension Arm Guide Roller (left)
  - B. Guide Roller (Impedance Roller)
  - C. Tape Lifter (left)
  - D. Fixed Tape Guide (left)
  - E. Erase Head
  - F. Record Head
  - G. Flutter Filter Roller
  - H. Tape Lifter (right)
  - I. Reproduce Head
  - J. Fixed Tape Guide (right)
  - K. Capstan Shaft
  - L. Tension Arm Guide Roller (right)
- (7) When all the above parts have been demagnetized, slowly move the demagnetizer at least 3 feet (1 meter) away from the MX-80 and turn it off or unplug it.

#### 4.2.3 Cleaning the Tape Path

It is extremely important to clean the entire tape path regularly. Oxide and dirt will be shed from the tape and accumulate on these parts, causing a build-up that can degrade audio performance, cause slipping, and cause undue wear on the tape.

**CAUTION:** Never use any metallic item or abrasive to clean the heads or any other tape guidance parts. Never use spirits, lacquer thinner, acetone or other solvents on the tape heads. Rubbing alcohol should be avoided since it contains oil that will leave a residue.

You should clean and demagnetize the entire tape path before performing any adjustments in this section.

- (1) Moisten a cotton swab in pure isopropyl alcohol, and wipe the entire surface of the Supply Tension Arm roller. Allow the roller to dry by evaporation.
- (2) Moisten additional swabs and clean the following parts:
  - A. Tension Arm Guide Roller (left)
  - B. Guide Roller (Impedance Roller)
  - C. Tape Lifter (left)
  - D. Fixed Tape Guide (left)
  - E. Erase Head
  - F. Record Head
  - G. Flutter Filter Roller
  - H. Tape Lifter (right)
  - I. Reproduce Head
  - J. Fixed Tape Guide (right)
  - K. Capstan Shaft
  - L. Tension Arm Guide Roller (right)

**CAUTION:** Don't use alcohol moistened swabs to clean the Tachometer Roller or the Pinch Roller. To avoid embedding dust and lint particles in the surface of these rollers, use only an alcohol moistened Lint-Free cloth to gently clean the rollers.

## Section 4

### 4.2.4 Input Level, Output Level and Peak Indicator Adjustment

NOTE: The MX-80 Outputs are set at the factory for balanced operation. If unbalanced operation is desired, set the BAL/UNBAL switch (SW1) on each Audio Amplifier PCB to the UNBAL position.

- (1) Set the test oscillator to produce a 1 kHz sine wave at + 4 dBm, using the AC voltmeter.
- (2) Connect the oscillator to the CH1 INPUT connector on the rear panel. Connect the AC voltmeter to the CH1 OUTPUT connector.
- (3) Extend the CH1 Audio Amplifier PCB using the Extender PCB (PB-7JEA). Turn On the Power to the MX-80.
- (4) Adjust VR14 (Input Level) on the Audio Amplifier PCB until the CH1 VU Meter indicates 0 VU.
- (5) Adjust VR12 (Output Level) until the AC voltmeter indicates + 4 dBm at the OUTPUT connector.
- (6) Connect the oscillator to the TEST SIGNAL input on the Audio Control PCB, and adjust VR13 (Test Signal Level) until the CH1 VU Meter indicates 0 VU.
- (7) Adjust the test oscillator to produce 1 kHz at + 12 dBm.

NOTE: This level causes the PEAK indicator to become illuminated at a level corresponding to 1040 nWb/m.

- (8) Adjust VR11 (Peak Indicator Level) on the Audio Amplifier PCB until the PEAK indicator in the CH1 VU Meter is steadily illuminated.
- (9) Repeat steps 2 through 8 for each remaining channel.

### Preliminary Record and Erase Transformer Peaking Adjustment

NOTE: This procedure is necessary only when a semi-permanent head format conversion is made, or if the Record or Erase Head are changed. It is not necessary to perform this procedure as part of the routine maintenance procedures.

- (10) Disconnect the test oscillator, and thread the machine with tape.

- (11) Connect the AC voltmeter to CP1 and CP2 (GND), and place the channel under alignment into Record mode.
- (12) Adjust TF1 (Record Bias transformer) on the Audio Amplifier PCB for a peak reading on the AC voltmeter.

NOTE: Use a non-metallic alignment tool for these adjustments.

- (13) With the machine still in Record mode, connect the AC voltmeter to CP3 and CP4 (GND), and adjust TF2 (Erase Bias transformer) for a peak reading on the AC voltmeter. For 24 and 32 CH machines the voltage at the peak should be 100 - 130 mV.
- (14) Repeat Steps 11 through 13 for all remaining Audio Amplifier PCBs. Replace PCBs when completed.

#### 4.2.5 Reproduce Head Azimuth Alignment

Refer to Figure 4-17 for the location and Reproduce Azimuth Adjustment screws.

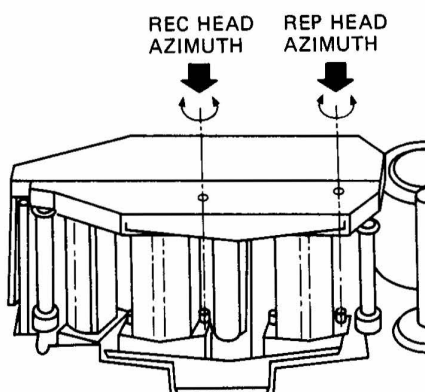

Figure 4-17 Record and Reproduce Azimuth Adjustment Screws

- (1) Set the Speed Mode Selector on the Remote Control Unit to the FIX position, and set the SPEED selector on the MX-80 transport to the L position. Set the ALL SAFE switch to the All Safe position. Press the ALL REPRO button on the Remote Control Unit.



## Section 4

- (2) Thread the MX-80 with an appropriate Reproduce Alignment Tape for the L speed setting. Refer to Section 4.2.1 for suggestions.
- (3) Connect one vertical input of the oscilloscope to the CH2 Output connector. Connect the other vertical input of the oscilloscope to the CH23 (CH15 on 16 channel versions, CH31 on 32 channel versions) Output connector. Adjust the oscilloscope vertical sensitivity so that the output signal from the MX-80 produces a usable display on the oscilloscope.
- (4) Insert the 2.5 mm hex key through the right hand hole in the head cover to the azimuth adjustment screw below. Locate and play the 1 kHz portion of the reproduce alignment tape. Adjust the oscilloscope controls until at least two complete cycles are displayed for each channel.
- (5) Adjust the Reproduce head azimuth adjustment screw (Figure 4-17) until the two signals displayed on the oscilloscope are in phase.

NOTE: The azimuth adjustment screw is on the right side of the head, and has a hex socket head. The slotted screw should not be adjusted.

- (6) Locate and play the 2 kHz portion of the alignment tape. Adjust the Reproduce head azimuth adjustment screw until the two signals on the scope are in phase.
- (7) Repeat Step 5 for each frequency on the alignment tape up to 16 kHz. The adjustment of the screw becomes more critical as the frequency increases.

### 4.2.6 Record Head Azimuth Adjustment

It is not possible to establish proper record head azimuth as a function of Record/Play phase response due to the record phase compensation circuits in the MX-80. The procedure given here adjusts the azimuth of the Record head in Sel-Rep mode, thus ensuring that the azimuth of the Record head is exactly matched to that of the Repro head.

- (1) Press the ALL SEL-REP button on the Remote Control unit.
- (2) Locate and play the 1 kHz portion of the reproduce alignment tape.

- (3) Adjust the Record head azimuth adjustment screw (the left hand hole in the head cover) until the two signals displayed on the oscilloscope are in phase.
- (4) Repeat Step 3 for each frequency on the alignment tape up to 16 kHz. The adjustment of the screw becomes more critical as the frequency increases.

#### 4.2.7 Reproduce Level Adjustment

NOTE: The MX-80 does not provide separate REPRO GAIN controls for each speed, therefore perform the Repro Level adjustment at the speed (H or L) which you will use most often. After performing the adjustments in Sections 4.2.7 through 4.2.15, when the tape speed is changed only the Repro Level adjustment needs to be re-adjusted. The Repro EQ adjustments will track the level adjustments.

- (1) Press the ALL REPRO button on the Remote Control unit.
- (2) Make sure the REF FLUX switch on the Audio Control PCB is set to correspond to the reference level of the Reproduce Alignment tape you are using. The H setting corresponds to 320 nWb/m, the L setting corresponds to 250 nWb/m.
- (3) Locate and play the portion of the alignment tape containing the 1 kHz tone at Reference Level. Adjust the REPRO GAIN trimmer on the front of the CH1 Audio Amplifier PCB until the CH1 VU Meter indicates 0 VU.
- (4) Repeat step 3 for each remaining Audio Amplifier PCB.

#### 4.2.8 Low Speed Reproduce Equalization Alignment

- (1) Set the SPEED selector on the MX-80 Transport to the L position. Press the ALL-REPRO button on the Remote Control unit.
- (2) Thread the MX-80 with an appropriate Reproduce Alignment Tape for the Reference Flux level and Equalization you are using.
- (3) Locate and play the 1 kHz portion of the alignment tape. If the VU Meter does not indicate 0 VU (it might not if Repro Gain was set at High speed), note the level which is indicated.

## Section 4

- (4) Play the equalization adjustment tones and adjust the REPRO EQ LOW SPD trimmer at 10 kHz for the same level as the 1 kHz tone in Step 3. You should adjust all the channels at the same time (writing down the results) to save wear on the reproduce alignment tape.

### 4.2.9 High Speed Reproduce Equalization Alignment

- (1) Set the SPEED selector on the MX-80 Transport to the H position. Press the ALL-REPRO button on the Remote Control unit.
- (2) Thread the MX-80 with an appropriate Reproduce Alignment Tape for the Reference Flux level and Equalization you are using.
- (3) Locate and play the 1 kHz portion of the alignment tape. If the VU Meter does not indicate 0 VU (it might not if Repr Gain was set at Low speed), note the level which is indicated.
- (4) Play the equalization adjustment tones and adjust the REPRO EQ HIGH SPD trimmer at 10 kHz for the same level as the 1 kHz tone in Step 3. You should adjust all the channels at the same time (writing down the results) to save wear on the reproduce alignment tape.

### 4.2.10 Sel-Rep Level Adjustment

NOTE: The MX-80 does not provide separate SEL-REP GAIN controls for each speed, therefore perform the Sel-Rep Level adjustment at the speed (H or L) which you will use most often.

- (1) Press the ALL SEL-REP button on the Remote Control unit.
- (2) Make sure the REF FLUX switch on the Audio Control PCB is set to correspond to the reference level of the Reproduce Alignment tape you are using. The H setting corresponds to 320 nWb/m, the L setting corresponds to 250 nWb/m.
- (3) Locate and play the portion of the alignment tape containing the 1 kHz tone at Reference Level. Adjust the SEL-REP GAIN trimmer on the front of the CH1 Audio Amplifier PCB until the CH1 VU Meter indicates 0 VU.
- (4) Repeat step 3 for each remaining Audio Amplifier PCB.



#### 4.2.11 Low Speed Sel-Rep Equalization Adjustment

- (1) Set the SPEED selector on the MX-80 Transport to the L position. Press the ALL-SEL-REP button on the Remote Control unit.
- (2) Thread the MX-80 with an appropriate Reproduce Alignment Tape for the Reference Flux level and Equalization you are using.
- (3) Locate and play the 1 kHz portion of the alignment tape. If the VU Meter does not indicate 0 VU (it might not if Sel-Rep Gain was set at High speed), note the level which is indicated.
- (4) Play the equalization adjustment tones and adjust the SEL-REP EQ LOW SPD trimmer at 10 kHz for the same level as the 1 kHz tone in Step 3. You should adjust all the channels at the same time (writing down the results) to save wear on the reproduce alignment tape.

#### 4.2.12 High Speed Sel-Rep Equalization Alignment

- (1) Set the SPEED selector on the MX-80 Transport to the H position. Press the ALL-SEL-REP button on the Remote Control unit.
- (2) Thread the MX-80 with an appropriate Reproduce Alignment Tape for the Reference Flux level and Equalization you are using.
- (3) Locate and play the 1 kHz portion of the alignment tape. If the VU Meter does not indicate 0 VU (it might not if Sel-Rep Gain was set at Low speed), note the level which is indicated.
- (4) Play the equalization adjustment tones and adjust the SEL-REP EQ HIGH SPD trimmer at 10 kHz for the same level as the 1 kHz tone in Step 3. You should adjust all the channels at the same time (writing down the results) to save wear on the reproduce alignment tape.



## Section 4

### 4.2.13 Low Speed Record Bias, Equalization, and Record Level Adjustment

The MX-80 provides switch selectable bias settings for two different tape formulations. At the Low tape speed, the Bias level for switch position A is fixed for AMPEX 456 tape. The Bias level for switch position B is adjustable for both speeds. Once the BIAS control on each Audio Amplifier PCB has been properly adjusted, a single control can reset the bias for all channels simultaneously.

NOTE: If the Low speed is 7-1/2 ips, set the oscillator level for -6 dBm and use 5 kHz for adjustment instead of 10 kHz.

- (1) Set the BIAS SELECT switch on the Audio Control PCB to the A position.
- (2) Set the test oscillator to produce a 10 kHz sine wave at +4 dBm, or whatever standard operating level you have chosen for your system, e.g., -10 dBv (-8 dBm).
- (3) Connect the test oscillator to the TEST SIGNAL input on the Audio Control PCB. Connect the AC voltmeter to the CH1 Output connector.
- (4) Thread the MX-80 with the tape ;you will use for sessions.
- (5) Press the ALL INPUT button on the Remote Control Unit.
- (6) Set the ALL SAFE switch to the Ready position.
- (7) Set the READY/SAFE switch to the Ready position for all channels.
- (8) Set the SPEED SELECT switch on the Transport to the L position, and set the Speed Mode Selector switch on the Remote Control Unit to the Fixed position.
- (9) Press the RECORD and PLAY buttons simultaneously to begin recording.
- (10) Press the ALL REPRO button on the Remote Control Unit.
- (11) Turn the RECORD BIAS trimmer on the CH1 Audio Amplifier PCB counterclockwise until the level on the AC Voltmeter begins to decrease.

- (12) Turn the RECORD BIAS trimmer clockwise until the indication on the AC Voltmeter peaks; then continue clockwise rotation until the AC Voltmeter reading decreases (overbias). Refer to Table 4-1 BIAS CHART the amount of overbias that is appropriate for the tape type and speed.
- (13) Set the oscillator to 1 kHz and adjust the RECORD GAIN LOW SPD trimmer for 0 VU (-10 VU for 7-1/2 ips).
- (14) Set the oscillator to 10 kHz and adjust the RECORD EQ LOW SPD trimmer for 0 VU (-10 VU for 7-1/2 ips).
- (15) Repeat Steps 11 through 14 for all remaining channels.

NOTE: If you wish to use a different tape formulation at Low speed, set the BIAS SELECT switch on the Audio Control PCB to the B position, thread the machine with the desired tape, and adjust the LOW SPD B trimmer for the desired bias level. This trimmer will adjust the bias for all channels simultaneously.

Section 4

Table 4-1 Recommended Record Bias Setting

Record Head: GH6R016 (32CH)  
 GH6R017 (24CH) (Wg = 6 um)

|                    |                    | Bias Setting $\Delta$ dB |       |     |     |
|--------------------|--------------------|--------------------------|-------|-----|-----|
|                    |                    | 3-3/4                    | 7-1/2 | 15  | 30  |
| Speed (ips)        |                    | 3-3/4                    | 7-1/2 | 15  | 30  |
| Frequency (Hz)     |                    | 10k                      | 10k   | 10k | 10k |
| Type<br>of<br>Tape | AGFA PEM468        |                          |       |     |     |
|                    | AGFA PEM169        |                          |       |     |     |
|                    | AMPEX 406/407      |                          |       |     |     |
|                    | AMPEX 456          |                          | 7.0   | 3.5 | 1.7 |
|                    | BASF LGR50P        |                          |       |     |     |
|                    | BASF SPR50LH/50LHL |                          |       |     |     |
|                    | SCOTCH(3M) 206/207 |                          |       |     |     |
|                    | SCOTCH(3M) 226/227 |                          | 7.0   | 3.5 | 1.7 |
|                    | SCOTCH(3M) 250     |                          |       |     |     |

(Unit: dB)

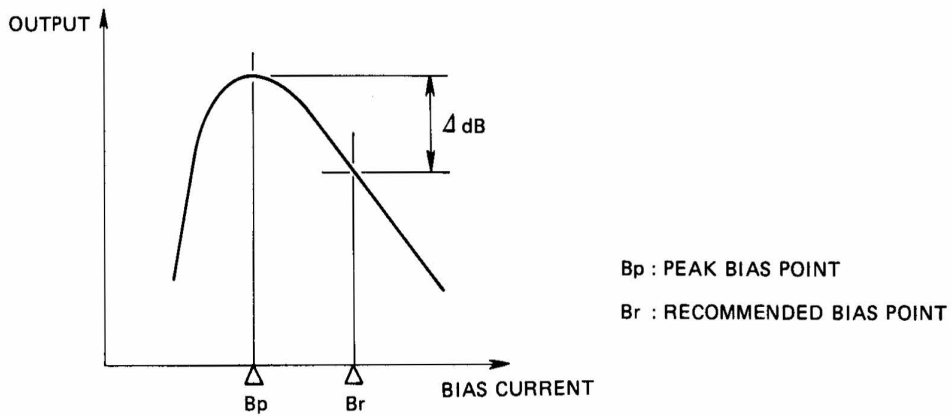

#### 4.2.14 High Speed Record Bias, Equalization, and Record Level Adjustment

- (1) Reset the BIAS SELECT switch on the Audio Control PCB to the A position, set the SPEED SELECT switch on the transport to the H position, thread the machine with a reel of the desired tape, and repeat Steps 7 through 12 of Section 4.2.13 (Low Speed Record Bias adjustment) using the HIGH SPD A trimmer on the Audio Control PCB for the desired amount of overbias.
- (2) Repeat Steps 13 through 15 of Section 4.2.13 using the RECORD GAIN HIGH SPD and RECORD EQ HIGH SPD trimmers.

To set the machine for an alternate tape type, having different bias requirements, at High speed, set the BIAS SELECT switch on the Audio Control PCB to the B position and repeat Step 2 above for all channels. Thereafter, whenever that tape type is to be used, set the BIAS SELECT switch to the B position, and the bias level for all channels is automatically adjusted for that tape type.

#### 4.2.15 Low Frequency Compensation Adjustment

- (1) Connect the test oscillator to the TEST SIGNAL input on the Audio Control PCB. Set the oscillator to produce 100 Hz at + 4 dBm.
- (2) Set the SPEED SELECT switch on the transport to the H position.
- (3) Press the ALL REPRO button on the Remote Control unit. Set the ALL SAFE switch to the Ready position.
- (4) Set the READY/SAFE switches for all channels to the Ready position.
- (5) Press the RECORD and PLAY buttons simultaneously to begin recording.
- (6) Adjust the REPRO LF COMP HI SPD trimmer for 0 VU on the MX-80 VU Meter. Repeat for each channel.
- (7) Rewind the tape to the beginning of the recorded section.
- (8) Press the ALL SEL-REP button on the Remote Control PCB.



## Section 4

- (9) Play the tape and adjust the SEL-REP LF COMP HI SPD trimmer for 0 VU on the MX-80 VU Meter. Repeat for each channel.
- (10) Set the SPEED SELECT switch on the transport to the L position.
- (11) Repeat Steps 3 through 9 using the REPRO and SEL-REP LF COMP LOW SPD trimmers.

### 4.2.16 Record Phase Compensation Adjustment

- (1) Set the SPEED SELECT switch on the transport to the H position. Press the ALL REPRO button on the Remote Control unit.
- (2) Set the test oscillator to produce a 10 kHz square wave, and connect it to the TEST SIGNAL input on the Audio Control PCB.
- (3) Connect the oscilloscope to either the CH1 OUTPUT on the rear panel, or to the 1/8" mini-jack LINE OUTPUT connector on the front of the CH1 Audio Amplifier PCB.
- (4) Press RECORD and PLAY to begin recording.

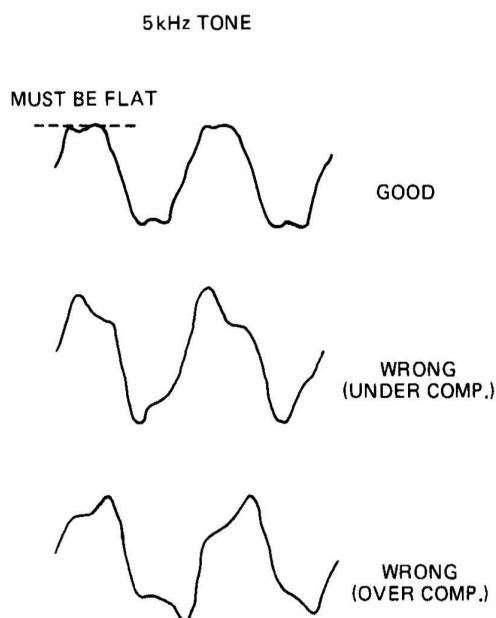

Figure 4-18 Record Phase Compensation Waveform

- (5) While recording the square wave, adjust the RECORD PHASE HI SPD trimmer for the best square wave response shown on the oscilloscope. (Refer to Figure 4-18).
- (6) Repeat for all remaining channels.
- (7) Set the SPEED SELECT switch on the transport to the L position and repeat Steps 3 through 6 using the RECORD PHASE LOW SPD trimmers. NOTE: Use 5 kHz for 7-1/2 ips adjustment.

#### 4.2.17 Erase Bias Symmetry Adjustment

NOTE: This adjustment is necessary only to minimize Punch In/Punch Out noise. It is not necessary to perform this procedure as part of normal maintenance procedures.

- (1) Clean and demagnetize the Heads and tape path.
- (2) Turn Off the power to the MX-80 and wait 30 seconds for the power supply capacitors to discharge.
- (3) Remove the Head Assembly Cover.
- (4) Unplug the Record Head connectors. The left-hand connector is for the upper tracks.
- (5) Thread the machine with a reel of the tape which is usually used for sessions. Set the SPEED SELECT switch on the transport for 15 ips operation.
- (6) Extend the CH1 Audio Amplifier PCB with the Extender PCB (PB-7JEA). Turn On the power to the machine.
- (7) Press the ALL REPRO button on the Remote Control unit, set the ALL SAFE switch to the Ready position, and set the CH1 READY/SAFE switch to the Ready position.
- (8) Connect an amplifier and monitor speaker to the CH1 OUTPUT connector on the rear panel.
- (9) Press PLAY and RECORD to begin recording.
- (10) While listening to the monitor speaker, repeatedly Punch In and Punch Out of Record. If any click or thump noise is heard, adjust VR23 (Erase Symmetry) on the Audio Amplifier PCB to minimize the noise.
- (11) Repeat Steps 6 through 10 for each remaining channel.

## Section 4

- (12) Reconnect the Record Head connectors and replace the Head Assembly Cover when the procedure is completed.

### 4.2.18 Record Bias Symmetry Adjustment

NOTE: This adjustment is necessary only to minimize Punch In/Punch Out noise. It is not necessary to perform this procedure as part of normal maintenance procedures.

- (1) Clean and demagnetize the Heads and tape path.
- (2) Turn Off the power to the MX-80 and wait 30 seconds for the power supply capacitors to discharge.
- (3) Remove the Head Assembly Cover.
- (4) Unplug the Erase Head connectors. The left-hand connector is for the upper tracks.
- (5) Thread the machine with a reel of the tape which is usually used for sessions. Set the SPEED SELECT switch on the transport for 15 ips operation.
- (6) Extend the CH1 Audio Amplifier PCB with the Extender PCB (PB-7JEA). Turn On the power to the machine.
- (7) Press the ALL REPRO button on the Remote Control unit, set the ALL SAFE switch to the Ready position, and set the CH1 READY/SAFE switch to the Ready position.
- (8) Connect an amplifier and monitor speaker to the CH1 OUTPUT connector on the rear panel.
- (9) Press PLAY and RECORD to begin recording.
- (10) While listening to the monitor speaker, repeatedly Punch In and Punch Out of Record. If any click or thump noise is heard, adjust VR22 (Record Symmetry) on the Audio Amplifier PCB to minimize the noise.
- (11) Repeat Steps 6 through 10 for each remaining channel.
- (12) Reconnect the Erase Head connectors and replace the Head Assembly Cover when the procedure is completed.

NOTE: If it is not possible to totally eliminate the thump or click noise, additional demagnetization might be necessary. Use a demagnetizer rated at 40 - 60 watts minimum.

#### 4.2.19 Gapless Punch-In/Punch-Out Test and Adjustment

NOTE: It is very important that the Erase Current and Record Bias adjustments be correctly performed prior to adjusting the Gapless timing.

- (1) Record a 1 kHz tone at 0 VU at 15 ips on all channels for 10 minutes, and Rewind to the beginning of the recorded section.
- (2) Set the GAPLESS RECORD switch (SW6) on the Audio Control PCB to the Off position.
- (3) Connect the CH8 Output to the CH1 Input. Press the INDIVIDUAL button on the Remote Control unit. Set CH8 to Sel-Rep mode. Set CH1 to Repro mode. Set the CH1 READY/SAFE switch to the Ready position, and set the ALL SAFE switch to the Ready position.
- (4) Connect the oscilloscope to the CH1 OUTPUT connector on the rear panel. Adjust the oscilloscope for a usable display (either 0.5 or 1.0 Sec/div).
- (5) Repeatedly Punch In and Out of Record on Channel 1 while observing the oscilloscope. The oscilloscope should display a 100 - 200 mSec overlap when Punching In, and a 100 - 200 mSec gap when Punching Out.
- (6) Repeat Steps 3 through 5 for all remaining channels. The results should be the same on all channels  $\pm$  20m Sec.
- (7) Set the GAPLESS RECORD switch (SW6) on the Audio Control PCB to the On position, and repeat Steps 3 through 5. Set the oscilloscope timebase for 5 or 10 m Sec/div. The oscilloscope should display a maximum overlap of 15 m Sec on Punching In, and a maximum gap of 15 m Sec on Punching Out. If correct results are not obtained, adjust the position of SW2-3, 2-4, and 2-5 on each Audio Amplifier PCB, to adjust the Punch Out gap, and adjust SW2-6, 2-7 and 2-8 to adjust the Punch In overlap. The Factory settings of SW2 are shown in Section 6.2.2.



SECTION 5:  
OPTIONAL EQUIPMENT AND FIELD UPGRADES

5.1 WIDE BAND MODIFICATION

The following modification is required for reproducing SMPTE/EBU Time Code in Fast Wind and Spooling modes.

- (1) Resolder J1 (located between IC3 and IC4) on the Audio Amplifier PCB Ass'y.
- (2) Solder a jumper wire to J2 (in the vicinity of IC1) instead.
- (3) Operate the following parts and solder them to the specified positions respectively.

|             |  |
|-------------|--|
| R501        | 1/4W, 5%, 6.2k ohm carbon resistor             |
| R502        | 1/4W, 5%, 3.6k ohm carbon resistor             |
| R503        | 1/4W, 5%, 1.2k ohm carbon resistor             |
| R504        | 1/4W, 5%, 360 ohm carbon resistor              |
| R505        | 1/4W, 5%, 1 M ohm carbon resistor              |
| R506        | 1/4W, 5%, 1 M ohm carbon resistor              |
| R507        | 1/4W, 5%, 1 M ohm carbon resistor              |
| Q501 - Q504 | 2SK336   |
| C501        | 0.1 uF Mylar film capacitor ( $\pm 5\%$ , 50V) |

When this modification is made, the MX-80 can reproduce Time Code from normal Play speed up to 25 times of Play speed, (referenced to 15 ips).

5.2 UPGRADING THE MX-80-24/32 FROM 24 TO 32 CHANNELS

The MX-80-24/32 is shipped as a 24 channel machine prewired for 32 channel operation. The parts required for this upgrade are contained in a kit with OTARI part number ZA-5BA.

Refer the exploded view drawings in Section 9.

## Section 5

- (1) Remove the head assembly cover by removing the two screws securing it to the transport.
- (2) Extract six head connectors, remove three hex socket screws retaining the head assembly to the deck plate, and remove the head assembly.
- (3) Fix the 32 channel head assembly to the deck plate using three hex socket screws which were removed in step 2.
- (4) Insert six head connectors, and return the head assembly cover to the original position.
- (5) Open the rear I/O panel by removing the two uppermost phillips head screws on each side of the panel, and hinging it down to horizontal.
- (6) Remove the blank panel covering the connector holes for 25th ch to 32nd ch attached to the I/O panel, and fix the XL-type connectors (16 pieces) by screws.
- (7) Insert connectors (4 each, 8 in total) of two cables included in the kit into the header of the mother board. (See Figure 5-1.)
- (8) Solder the cable to the pins of the XL-type connectors. (See Figure 5-1. Exercise care not to mix up hot, cold and GND.)
- (9) Return the panel to the original position after confirmation that all cable connections are correct.
- (10) Remove the Phillips type head screw locating at each of both upper ends of the panel and retaining the VU meter panel to the transport, and tilt the panel toward you.
- (11) Extract the flat cables out of three VU meter PCBs. (Exercise care not to make erroneous connection at a later step.)
- (12) Remove the inner panel to which VU meters are mounted.
- (13) Replace the Lower Angle (which masks 25ch - 32ch VU meters) with narrower width panel included in the kit.
- (14) Mount the VU meters (8 pieces) with nuts to the inner panel.  
Fix the RECORD IND PCBs and PEAK IND PCBs (8 pieces each) to the inner panel by screws.
- (15) Mount the inner panel to the VU meter panel.

- (16) Fix the VU meter PCB (contained in the kit) to the VU meters by screws. (4 screws per VU meter)
- (17) Insert the connectors of RECORD IND PCBs and PEAK IND PCBs into the headers on the VU meter PCB.
- (18) Insert the flat cable included in the kit to the connector on the VU meter PCB, and insert another end of the cable to CN38 on the mother board.
- (19) Mount the VU meter panel to the transport.
- (20) Insert eight Audio Amplifier PCBs into the card frame.  
Installation has been completed as a result. Then;
- (21) Align the Audio Amplifier PCB using the procedures described in Section 4.2.

### 5.3 INSTALLATION OF OVERBRIDGE CASE FOR DOLBY NOISE REDUCTION SYSTEM

- (1) Mount trim plates A(No.3) to the top and bottom of side trims 2. Secure each with two M3x10 hex socket head screws. Secure trim plate B(No.4) to side trims 2 using M3x10 flat countersunk head screws on each side.
- (2) Mount the parts assembled in step 1 in the overbridge case 1. Secure with four M4x10 hex socket head screws on each side.
- (3) Insert two spacers 9 and two casters 10 into the bottom support 8. Secure side panel L(No.5) and side panel R(No.6) to the bottom support 8 with two M4x10 hex socket head screws on each side.
- (4) Mount the parts assembled in step 3 to the MX-80 case frame from the rear. Secure with five M8x10 hex socket head screws. These screws should not be tightened completely at this time.
- (5) Mount the cover 7 between side panel L5 and side panel R6. Secure with M3x6 hex socket head screws from the inside of the cover. Tighten M4x10 and M8x10 hex socket head screws from steps 3 and 4 completely.
- (6) Mount the overbridge case 1 onto side panel L5 and side panel R6. Secure with two M5x8 binding head screws on each side.

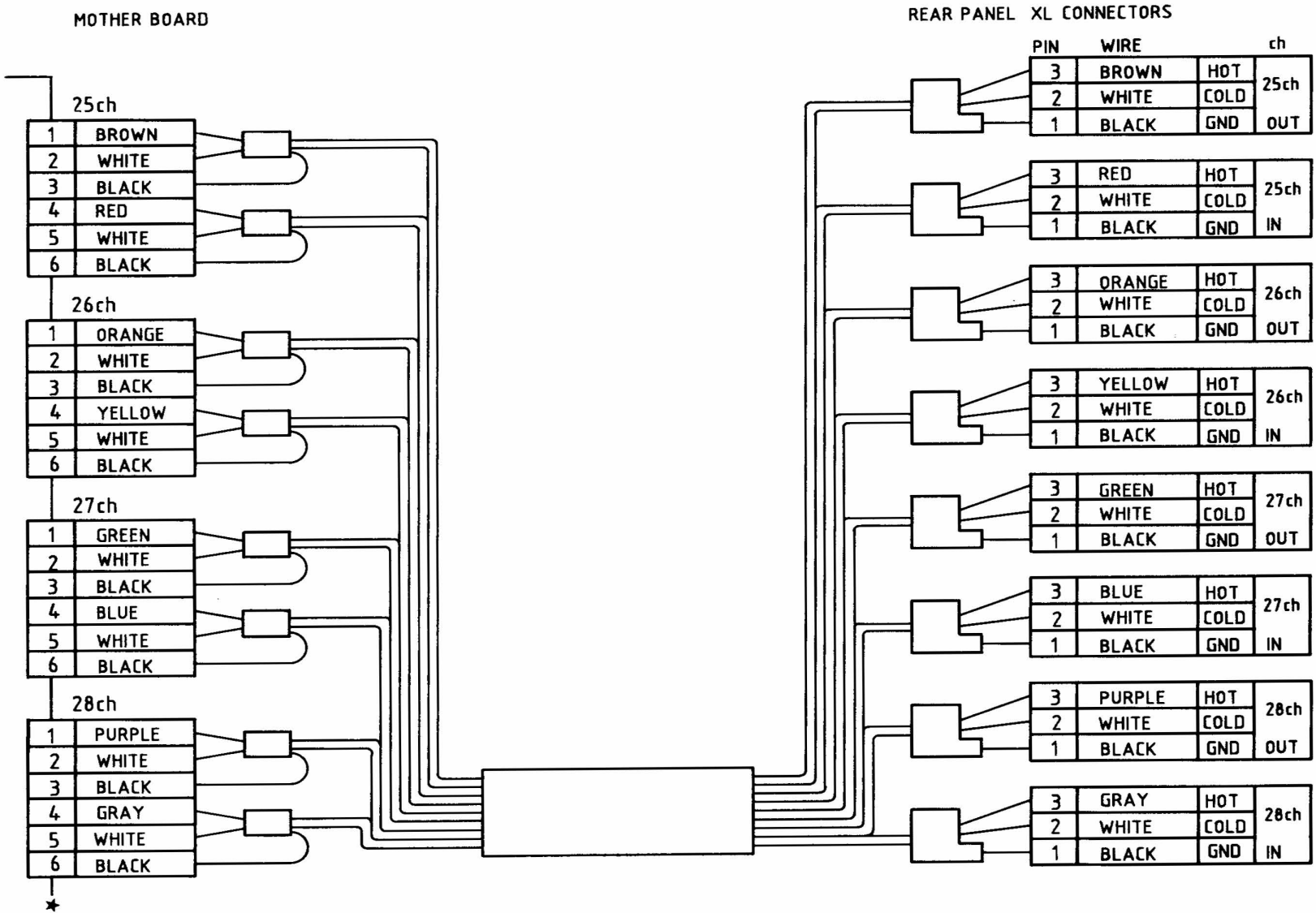

Figure 5-1a Upgrade Modification



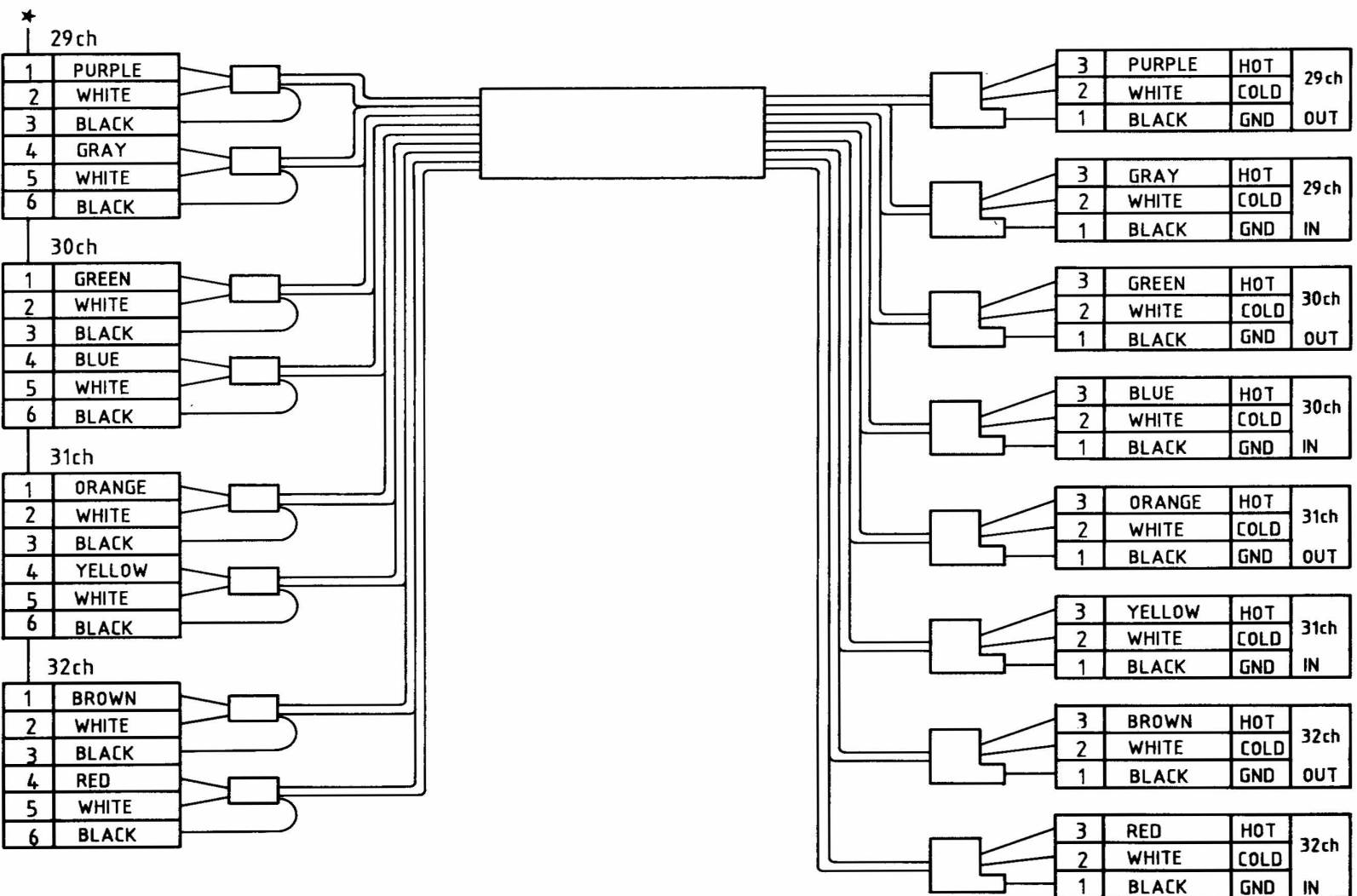

Figure 5-1b Upgrade Modification

Section 5

- (7) Attach the floating nuts from the rear of trim plates 2 as illustrated.
- (8) Mount the blank panel 11 from the front. Secure with eight M4x12 binding head screws.
- (9) Mount the noise reduction system and power supply unit from the front. Secure with four M4x12 binding head screws.
- (10) Verify that all screws have been completely tightened.

NOTE: Due to weight of this assembly, we suggest that this installation be done with the help of another person.

PARTS LIST

| Ref. No. | Description     | Quantity |
|----------|-----------------|----------|
| 1        | Overbridge Case | 1        |
| 2        | Side Trim       | 2        |
| 3        | Trim Plate A    | 2        |
| 4        | Trim Plate B    | 2        |
| 5        | Side Panel L    | 1        |
| 6        | Side Panel R    | 1        |
| 7        | Cover           | 1        |
| 8        | Bottom Support  | 1        |
| 9        | Spacer          | 2        |
| 10       | Caster          | 2        |
| 11       | Blank Panel     | 2        |

LIST OF SCREWS

| Type                              | Quantity | Code     |
|-----------------------------------|----------|----------|
| M3x 6 Hex Socket Head Screw       | 6        | C3x 6B   |
| M3x10 Hex Socket Head Screw       | 4        | C3x10B   |
| M3x10 Flat Countersunk Head Screw | 4        | F3x10N   |
| M4x10 Hex Socket Head Screw       | 12       | C4x10B   |
| M5x 8 Binding Head Screw          | 10       | B5x 8B   |
| M5x20 Binding Head Screw          | 20       | B5x20B   |
| Floating Nut                      | 20       | F951Z004 |
| M8x10 Hex Socket Head Screw       | 16       | C8x10B   |

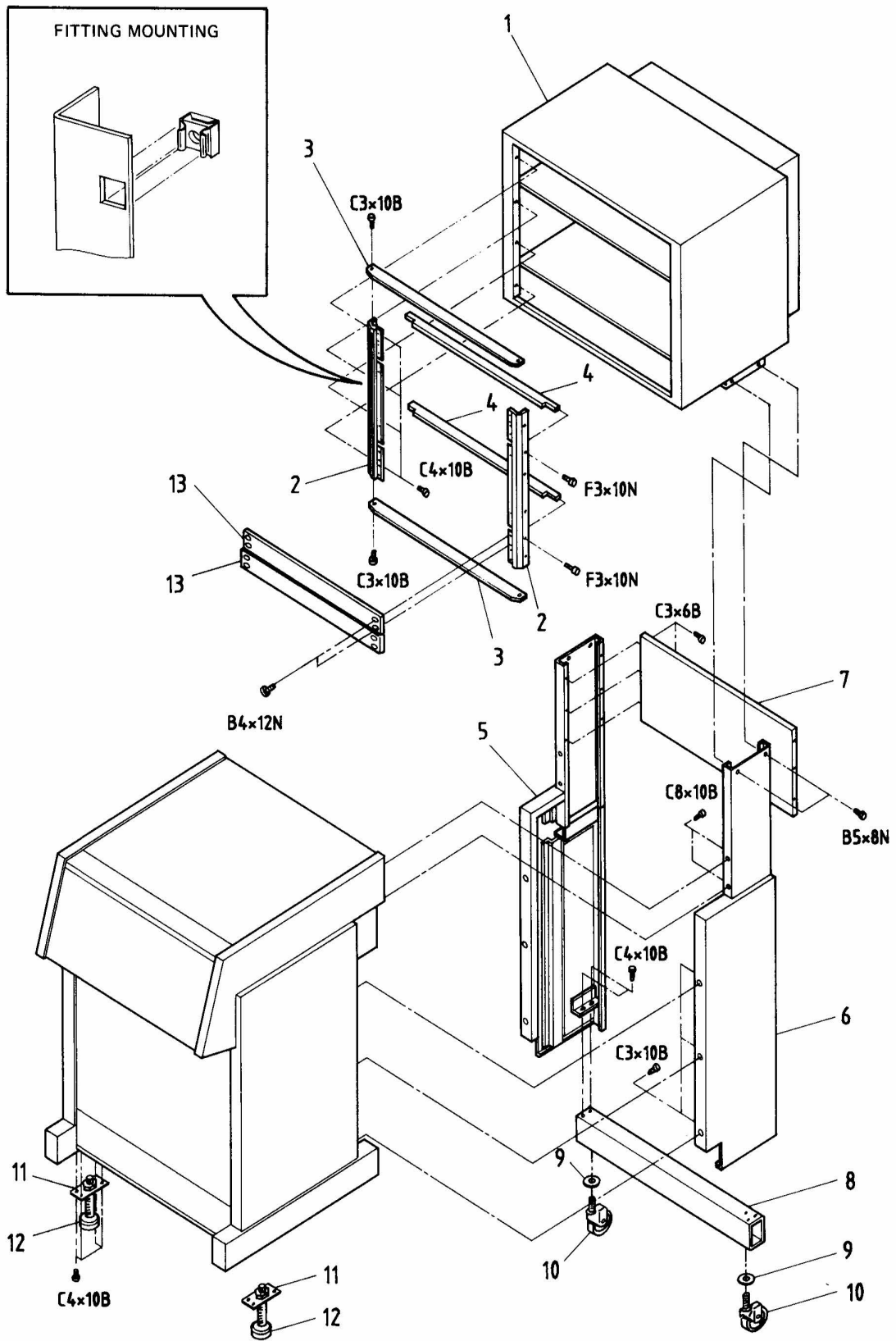

Figure 5-2 Overbridge Case Assembling

## SECTION 6: INSTALLATION INSTRUCTIONS

### 6.1 UNCRATING THE MACHINE

MX-80 Series Recorders are shipped fully assembled (including casters) on a wood pallet, with a heavy cardboard carton containing a form-fitting foam packing insert surrounding the machine, strapped to the pallet. A separate box, under the machine, contains an AC power cord, spare lamp assemblies for control buttons, and a spare fuse. We recommend that you open the carton carefully and retain the packing materials at least until proper operation of the machine has been established.

NOTE: MX-80 machines delivered in the United States have been uncrated and checked by OTARI Corporation and the dealer, making these steps necessary only if the machine has been recrated for delivery to your facility. Even so, you may wish to perform the checks and inspections in this Section to become familiar with the machine.

### 6.2 INSPECTION

Before you make any electrical connections, the MX-80 should be inspected visually. If there is any evidence of damage due to rough handling in shipping, you must notify the transportation carrier and submit a claim. Do not connect or use the MX-80 until you have successfully completed this inspection.

#### 6.2.1 Audio Control PCB

Release the six nylon latches that hold the Amplifier panel in place on the front of the machine by pulling out on the buttons. The buttons will "pop" out about 1/8" (3 mm), releasing their hold on the chassis behind the panel. The panel will then remove to reveal the Audio Control and Audio Amplifier PCBs.

Grasp the edges of the PCB front panel at the top of and bottom of the Audio Control PCB (the leftmost PCB), and pull straight out to extract the board.

NOTE: Numbers in brackets [ ] refer to callouts in Figure 6-1.



Section 6

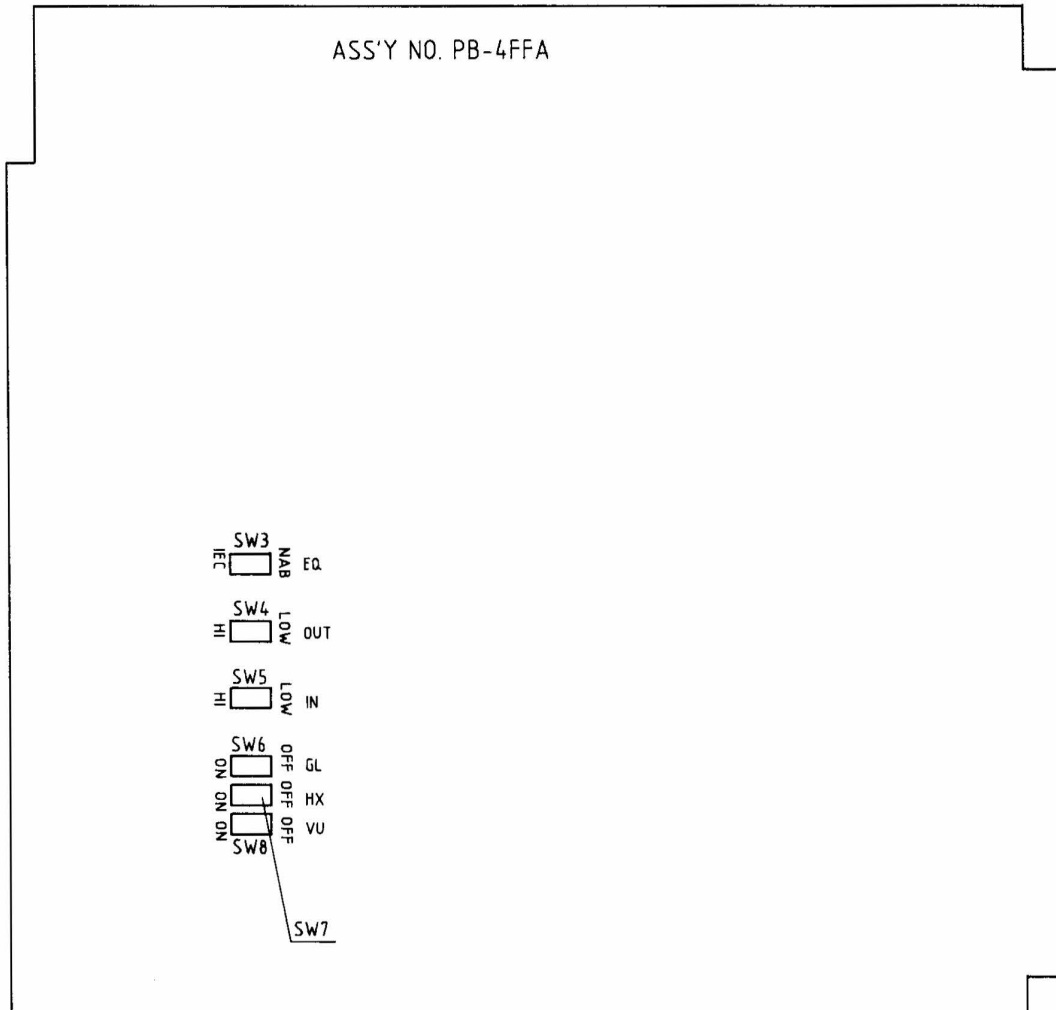

Figure 6-1 Location of Switches on Audio Control PCB

[1] SW3 EQ IEC/NAB switch

It should be set to the EQ position required for the type of machine you ordered.

[2] SW4 OUTPUT LEVEL +4dBm/-8dBm switch

It is set to +4 dBm at the time of shipment from the factory.

[3] SW5 INPUT LEVEL +4dBm/-8dBm switch

It is set to +4 dBm at the time of shipment from the factory.

[4] SW6 GAPLESS RECORD ON/OFF switch

It is set to the "ON" position at the time of shipment from the factory.

[5] SW7 DOLBY HX PRO ON/OFF switch

It is set to the "ON" position at the time of shipment from the factory.

[6] SW8 VU +10dB ON/OFF switch

It is set to the "OFF" position at the time of shipment from the factory.

### 6.2.2 Audio Amplifier PCBs

Grasp the intermost edge of the white extractor tab at the top of the Channel 1 Audio Amplifier PCB and pull outward to extract the board. Refer to Figure 6-2 for the location of the various controls on the Audio Amplifier PCB. Check the following switches on the PCB:

(1) SW1: BAL/UNBAL switch - Set to BAL at the factory.

(2) SW2: Gapless Punch-In switch

A. Erase/Record Head Distance Compensation  
SW2-1 on, SW2-2 on

B. Punch-Out Timing  
SW2-3 on, SW2-4 on, SW2-5 off

C. Punch-In Timing  
SW2-6 on, SW2-7 on, SW2-8 off

Section 6

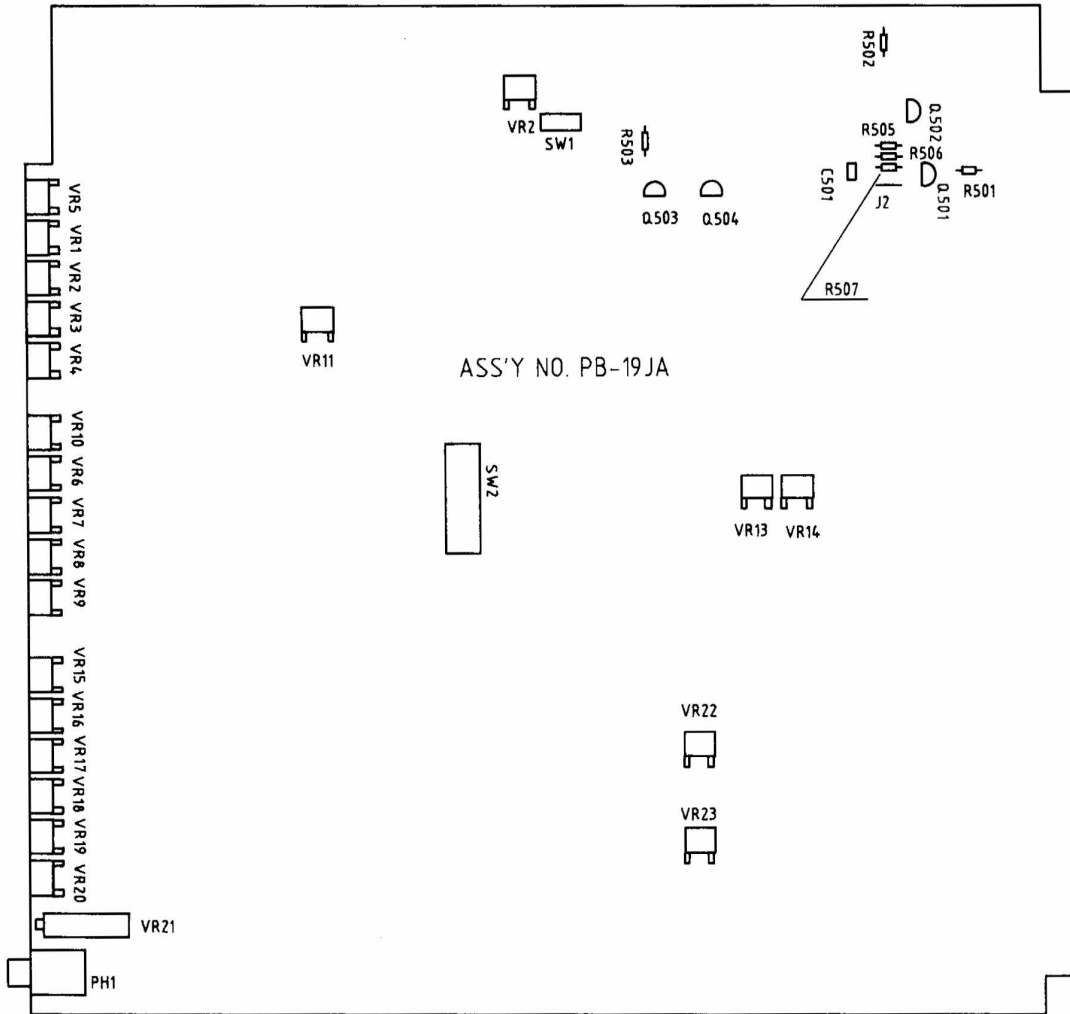

Figure 6-2 Audio Amplifier PCB

6.2.3 Serial Remote Control PCB

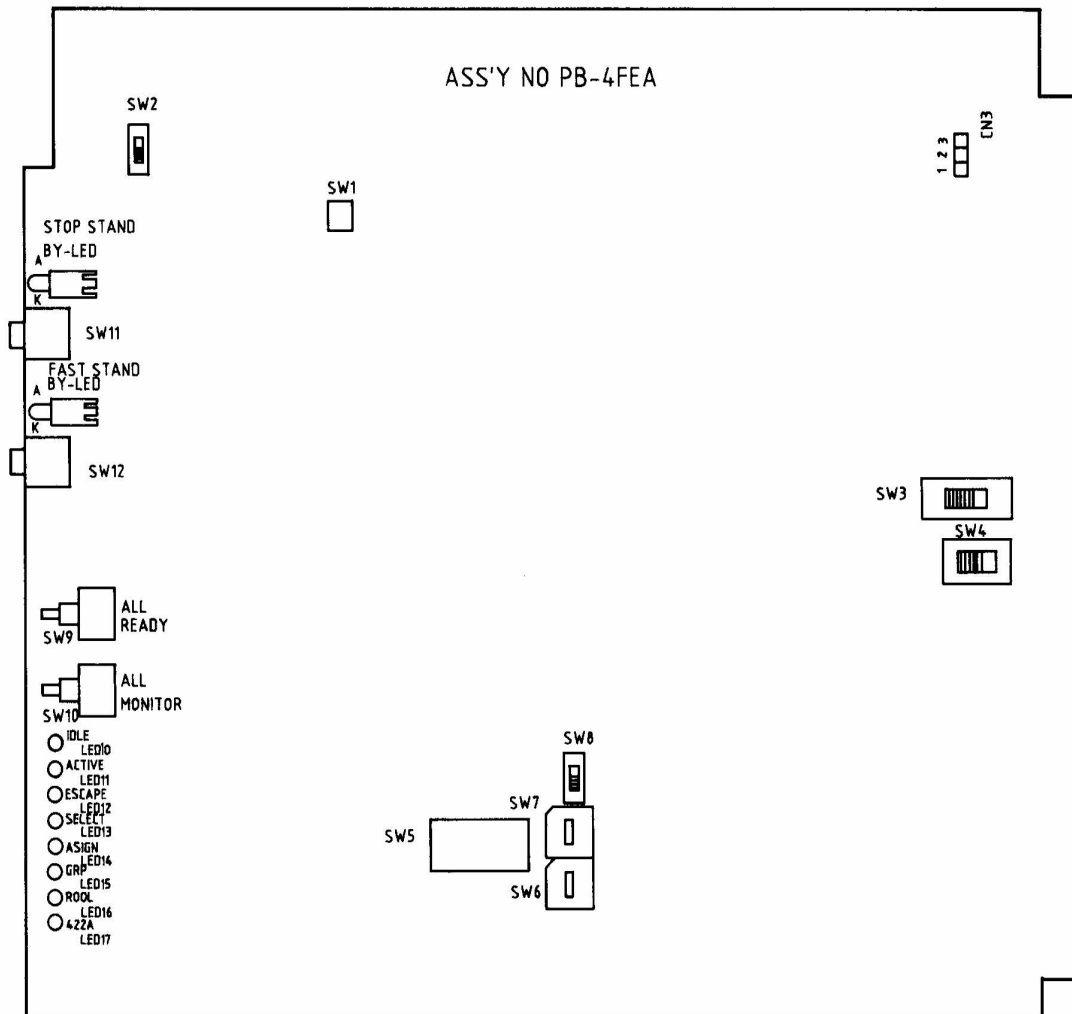

Figure 6-3 Serial Remote Control PCB



## Section 6

This PCB is located at the right-hand end of the lower card cage.

The following controls are located on this PCB.

- SW1: CPU Reset switch.
- SW2: Test switch which should be normally on.
- SW3: Switch for selection of whether MX-80 becomes the system's terminal or the host (RS-232C).
- SW4: Switch for selection of whether MX-80 becomes the system's terminal or the host (RS-422A).
- SW5: Switch for selection of whether MX-80 becomes the system's terminal or the host (RS-422A).
- SW6, 7: Switches for setting the address No. of the machine that controls with RS-422A. SW6 is for the digit of 10 and SW7 is for the digit of 1. However, the maximum setting value shall be 32.
- SW8: Not used.
- SW9: Switch for selecting whether to set all channels in the Ready mode or in the Safe mode (for test).
- SW10: Switch for selecting the monitor mode of all channels (for test).
- SW11: ON/OFF switch for the Stop Standby mode.
- SW12: ON/OFF switch for the Fast Standby mode.
- CN3: Jumper connector for setting whether to output tach pulses to the Serial I/O connector or not.

Inquire OTARI for detail information regarding external control of the recorder with RS-232C or RS-422A.

### 6.2.4 Transport Control PCB

Open the upper rear panel of the MX-80 by removing two philips head screws on each side of the panel and hinging it down to horizontal.

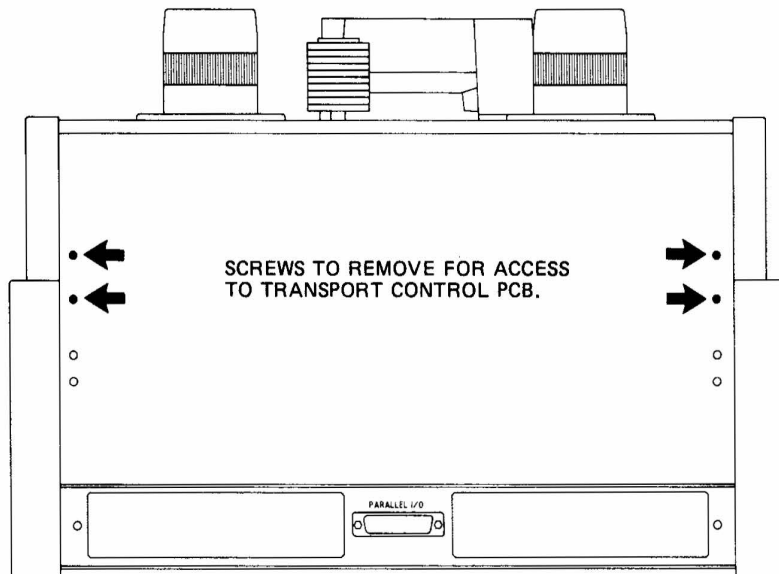

Figure 6-4 Screws to Remove for Access to Transport Control PCB

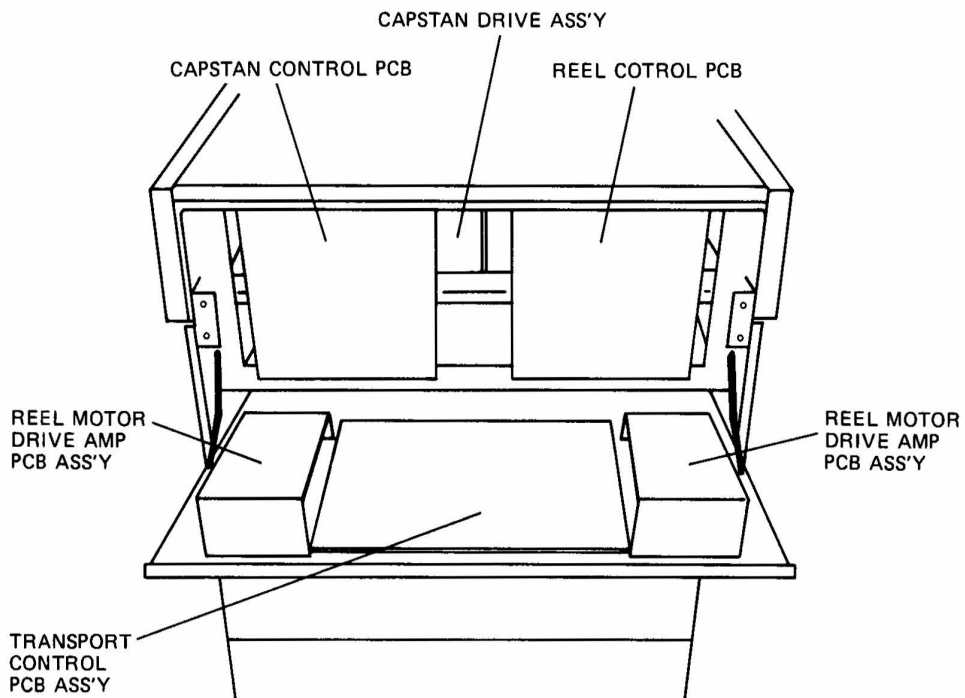

Figure 6-5 Inside View of Rear MX-80

## Section 6

Check the following PCBs for loose or damaged connectors or components:

1. Transport Control PCB
2. Reel Control PCB
3. Capstan Control PCB
4. Reel Motor Drive Amplifier PCBs

There are many function selection switches on the control PCB assembly as described on the Table 6-1. Check each switches allocation or reset them as you like.

Close the rear panel and secure it with the four screws removed earlier.

NOTE: As for function selection switches on the Control PCB assembly, some switches are provided double on the Remote Control Unit PCB assembly. So some functions can be selected differently each other.

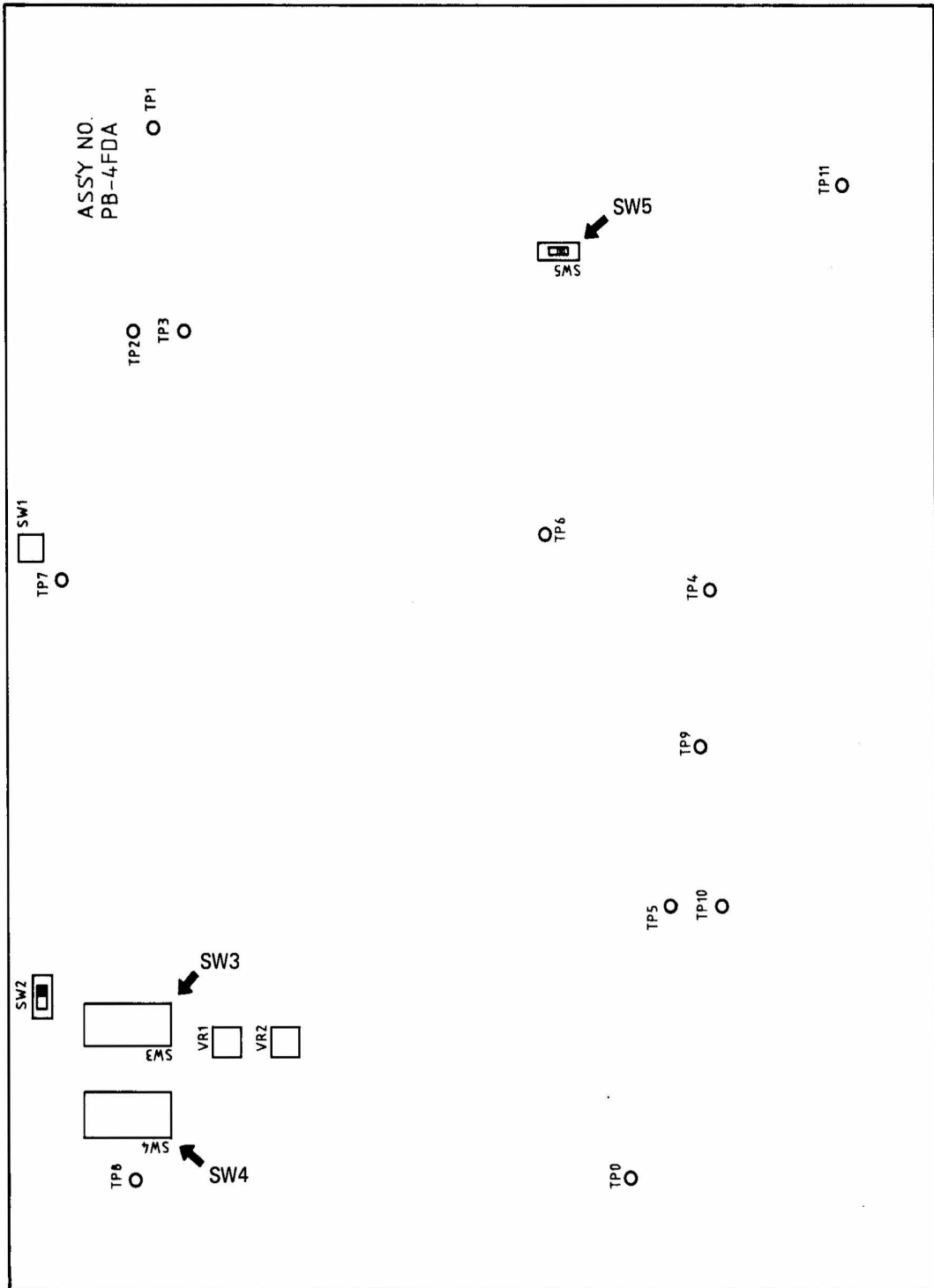

Figure 6-6 Transport Control PCB



## Section 6

Table 6-1 Switches on the Transport Control PCB

| SW No. | Function   | Initial position               |
|--------|--|--------------------------------|
| SW1    | CPU Reset  | ---                            |
| SW2    | Speed Pair Select  | H or L<br>depeding on<br>model |
| SW3-1  | Record Punch-In  | Off                            |
|        | When in the Off position, pressing the RECORD button, when in Play mode, causes the MX-80 to enter Record.                         |                                |
|        | When in the On position, pressing the RECORD and PLAY buttons simultaneously, when in Play mode, causes the MX-80 to enter Record. |                                |
| SW3-2  | Record Punch-Out   | Off                            |
|        | When in the Off position, pressing the PLAY button, when in Record mode causes the MX-80 to leave Record.                          |                                |
|        | When in the On position, holding the RECORD button pressed and pressing the STOP button causes the MX-80 to leave Record.          |                                |
| SW3-3  | Lifter Defeat  | Off                            |
|        | When in the Off position, the tape lifters do not retract when the CUE button is pressed.  |                                |
|        | When in the On position, the tape lifters retract when the CUE button is pressed.  |                                |

| SW No. | Function   | Initial position |
|--------|--|------------------|
| SW3-4  | Tach Pulse Rate Switch   | Off              |
|        | When in the Off position, the Tach Pulse rate at the Parallel I/O connector is 240 pulses per second at 30 ips (SMPTE rate). |                  |
|        | When in the On position, the Tach Pulse rate at the Parallel I/O connector is 200 pulses per second at 30 ips (EBU rate).    |                  |
| SW3-5  | Play-to-Stop Audio Mute  | Off              |
|        | When in the Off position, the audio output is briefly muted when the tape is stopped from Play mode.                         |                  |
|        | When in the On position, the audio output is not muted when the tape is stopped from Play mode.                              |                  |
| SW3-6  | Stop-to-Play Audio Mute  | Off              |
|        | When in the Off position, the audio output is muted until the tape reaches play speed when entering Play from Stop mode.     |                  |
|        | When in the On position, the audio output is not muted when entering Play from Stop mode.                                    |                  |
| SW3-7  | Auto Memory for Play Start   | Off              |
|        | When in the On position, the location at the transport was last placed in Play mode is automatically stored in Cue point 3.  |                  |
|        | When in the Off position, the location is not stored.  |                  |

Section 6

| SW No. | Function   | Initial position |
|--------|--|------------------|
| SW3-8  | Add Channel into Record  | Off              |
|        | <p>When in the Off position, you can add channels into Record by setting the channel's Ready/Safe switch to the Ready Position, when in Record mode.</p> <p>When in the On position, you must press RECORD (or RECORD and PLAY depending on the position of SW3-1) to add channels into Record.</p>                                      |                  |
| SW4-1  | Parallel I/O Rehearsal Enable  | Off              |
|        | <p>When in the Off position, the Rehearsal function cannot be accessed from the Parallel I/O connector.</p> <p>When in the On position, the Rehearsal function can be accessed from the Parallel I/O connector.</p> <p>NOTE:<br/>This switch should be in the On position to use the Rehearse function from the CB-120 Auto Locator.</p> |                  |
| SW4-2  | Automatic Memory Back-up   | Off              |
|        | <p>When in the Off position, the Cue Locations stored will be lost whenever the Power to the MX-80 is turned Off or disconnected.</p> <p>When in the On position, the Cue Locations stored will remain in memory even when the Power to the MX-80 is turned off or disconnected.</p>   |                  |

| SW No.              | Function  | Initial position |
|---------------------|---|------------------|
| SW4-3               | Head Shield   | Off              |
|                     | When in the Off position, the Head Shield plate is manually operated.   |                  |
|                     | When in the On position, the Head Shield Plate will "pop up" automatically each time the MX-80 enters Play or Record mode, if it was retracted. |                  |
| SW4-4<br> <br>SW4-8 | Not Used  |                  |

#### 6.2.5 Power Supply Panel

Open the lower rear Power Supply panel (containing the regulator heat sinks) by removing two phillips head screws on each side of the panel and hinging it down to horizontal.

Check the connectors and wiring leading to the power supply PCB located on the panel. Also check the connectors on the Voltage Select PCB.

Close the lower rear Power Supply panel and secure it with the four screws removed earlier.



## Section 6

### 6.2.6 Transport Assemblies

Remove any tape and empty reels from the machine. Open the VU Meter Panel by removing two phillips head screws located in the upper corners of the panel. Open the transport by removing the two socket head screws on the left and right sides under the deck plate, that attach the transport to the chassis. Lift the transport, and carefully check the following items:

- (1) Switch PCB Ass'y #1 (PB-7AJB)  
This PCB is connected to the Transport Control switches (PLAY, RECORD, F.FWD, REWIND, STOP).
- (2) Switch PCB Ass'y #2 (PB-7AKA)  
This PCB is connected to the 2nd FUNCTION, CUE, and EDIT/UNLOAD switches.
- (3) Tape Timer PCB Assemblies (PB-7HTA, -7HUA)  
This PCB is connected to the Tape Timer mechanism, and the SEARCH, SET, REPEAT, CLR, and TIME-IPS-% switches.
- (4) Check the connectors on the Tach PCB assemblies #1 (PB-7DRA) and #2 (PB-7DSA).
- (5) Check the connectors coming from both Tension Sensor Ass'ys (Left and Right).
- (6) Check the connectors coming from the Safety Switch Ass'ys (Left and Right) (PB-4FHA).
- (7) Check the connectors coming from each of two Reel drive PCBs (PB-4FCA) and from the Reel Control PCB (PB-4FBA).
- (8) Check the connectors coming from the Capstan Control PCB (PB-4FAA).
- (9) Check the connectors from the five solenoids; one each from Pinch Roller and Tape Lifters, one for each of the Reel Brakes, and one for the Head Shield Plate mechanism.

If all connections are correct, close the transport, re-install the four screws that hold the transport to the chassis, and close the VU Meter Panel and secure it with the two screws removed earlier.

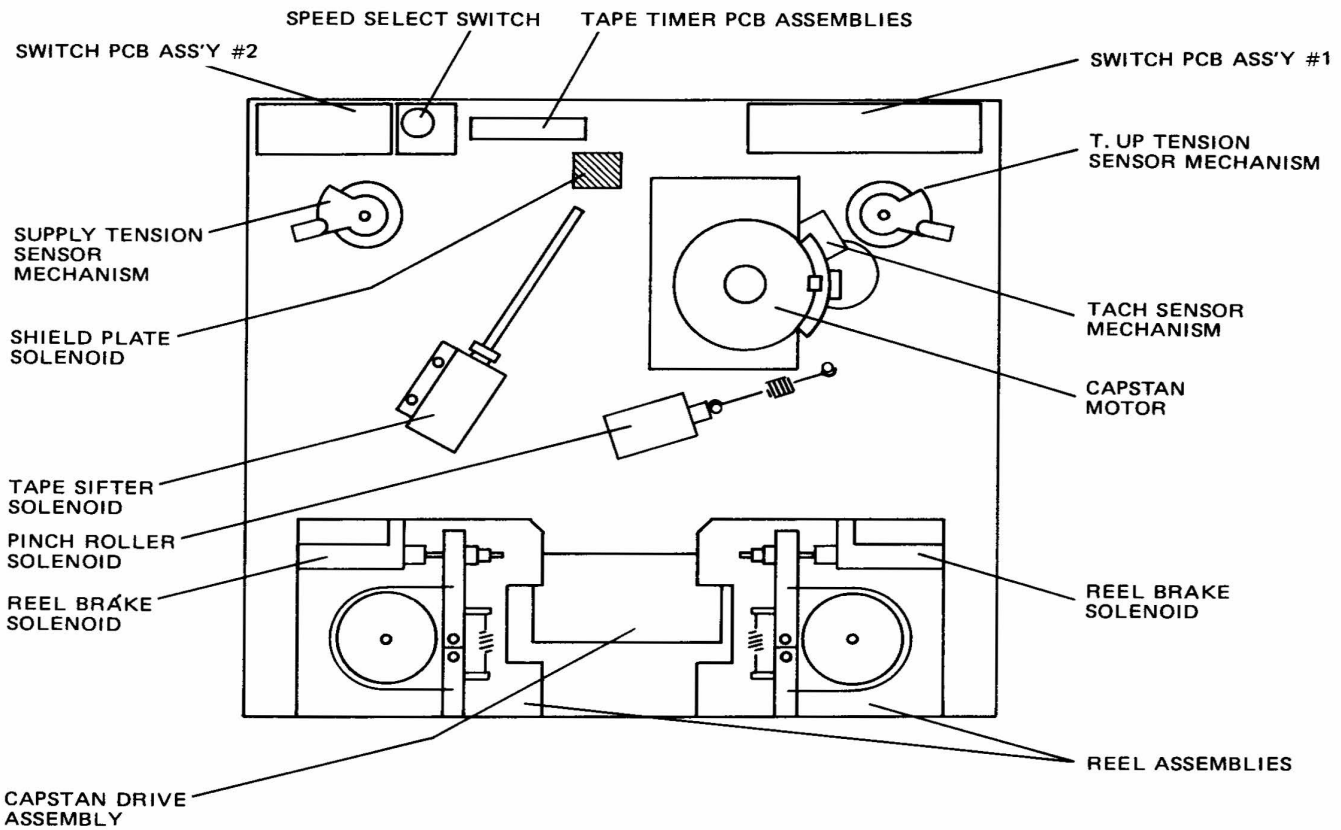

Figure 6-7 Location of Transport Assemblies

## Section 6

## 6.2.7 Remote Control Unit

There are several function selection switches and jumpers on the CPU PCA(PB-4FGA) as described on the Table 6-2. Check each switches allocation or reset them as you like.

Table 6-2 Switches and Jumpers on the CPU PCA(PB-4FGA)

| SW No. | Function  | Initial position |
|--------|---|------------------|
| SW1-1  | Record Punch-In<br><br>Same as SW3-1 on Transport Control PCB. Refer to page 6-10.  | Off              |
| SW1-2  | Record Punch Out<br><br>Same as SW3-2 on Transport Control PCB. Refer to page 6-10.   | Off              |
| SW1-3  | SW Mode Selection<br><br>When in the Off position, Amplifier Monitor mode can be changed directly when you press the button.<br><br>When in the On position, monitor mode can be only changed by pressing Reset button before pressing the button of the mode you desire. | Off              |
| SW1-4  | Auto set-up Selection<br><br>When in the Off position, channel set-up for the Audio channels is automatically stored when selection keys are controlled.<br><br>When in the On position, channel set-up is not stored automatically.                                      | On               |

| SW No.              | Function  | Initial position |
|---------------------|---|------------------|
| SW1-5               | Error Message Display   | On               |
|                     | When in the On position, Error Message will be displayed when malfunction has occurred(Refer to Table 6-3). |                  |
|                     | When in the Off position, Error Message is not displayed on malfunction.                                    |                  |
| SW1-5<br> <br>SW1-8 | Not used.   |                  |
| J1,3,4              | Not used.   |                  |
| J2,5                | Set when ROM 256 used type selection. No jumper for 24CH, jumpered for 32CH.                                |                  |
| J6,7                | Always jumpered.  |                  |
| SW2                 | CPU all reset.  |                  |



Section 6

Table 6-3 AMP Remote Control Uniot Error Message

| Error code | Message  |
|------------|--|
| 00         | ROM Check SUM Error                            |
| 01         | RAM READ/WRITE Error                           |
| 04         | Back Up Error                                  |
| 90         | Initial Commuication Error                     |
| 91         | Time-out Error in Communication with Transport |
| 92         | Undefine Error                                 |
| 93         | Check SUM Error on Receiving Command           |
| 94         | No Acknowledge Signal was received             |
| 95         | Parity Error                                   |
| 96         | Double Data Error                              |
| 97         | Framing Error                                  |
| 98         | Buffer Error                                   |
| 99         | STX Signal is not found                        |

### 6.3 HOOKING UP THE MX-80

#### 6.3.1 Hooking up the AC Power

The AC power is supplied to the MX-80 via a three-conductor IEC standard connector. Insure that voltage and frequency supplied to the MX-80 agree with the machine's power requirements printed on the serial number label on the rear panel of the machine, before applying power. Use the power cord supplied with the machine. Figure 6-8 describes the wiring of the AC input connector.

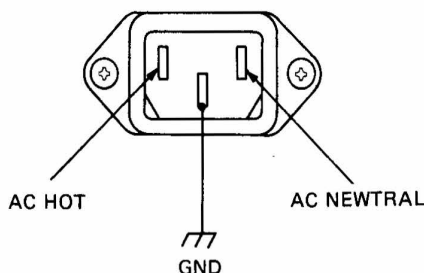

Figure 6-8 AC Power Connector

#### 6.3.2 Hooking up the Audio Inputs and Outputs

Connect the buss or track outputs from the mixing console to the Inputs of the MX-80. Connect the Outputs from the MX-80 to the monitor or tape inputs of the mixing console.

The Input to each channel of the MX-80 is transformerless balanced and has an input impedance of 10k ohm. Pin 1 of the connector is connected to the shield or drain, Pin 2 is connected to the "Cold" side of the signal, and Pin 3 is connected to the "Hot" side of the signal. If unbalanced Input wiring is desired, connect only to Pin 1 (shield) and Pin 3 (hot). Do not connect Pin 2 to either Pin 1 or Pin 3. See Figure 6-9 and 6-10 for details of input connector wiring.

Section 6

The Output from each channel is transformerless, balanced or unbalanced, and has an output impedance of less than 5 ohm. Pin 1 of the connector is connected to the shield or drain, Pin 2 is connected to the signal "cold" or "low" conductor, and Pin 3 is connected to the signal "hot" or "high" conductor. When the Unbalanced operation is required, set the BAL/UNBAL switch (SW1) on the Audio Amplifier PCB to the UNBAL position. The OUTPUT connector for Unbalanced operation is wired with Pin 1 connected to the shield, and Pin 3 connected to the signal "hot" or high side (center conductor). Do not connect Pin 2 to either Pin 1 or Pin 3. The level of the Output signal will be approximately 6 dB lower than normal if the BAL/UNBAL switch is incorrectly set to BAL.

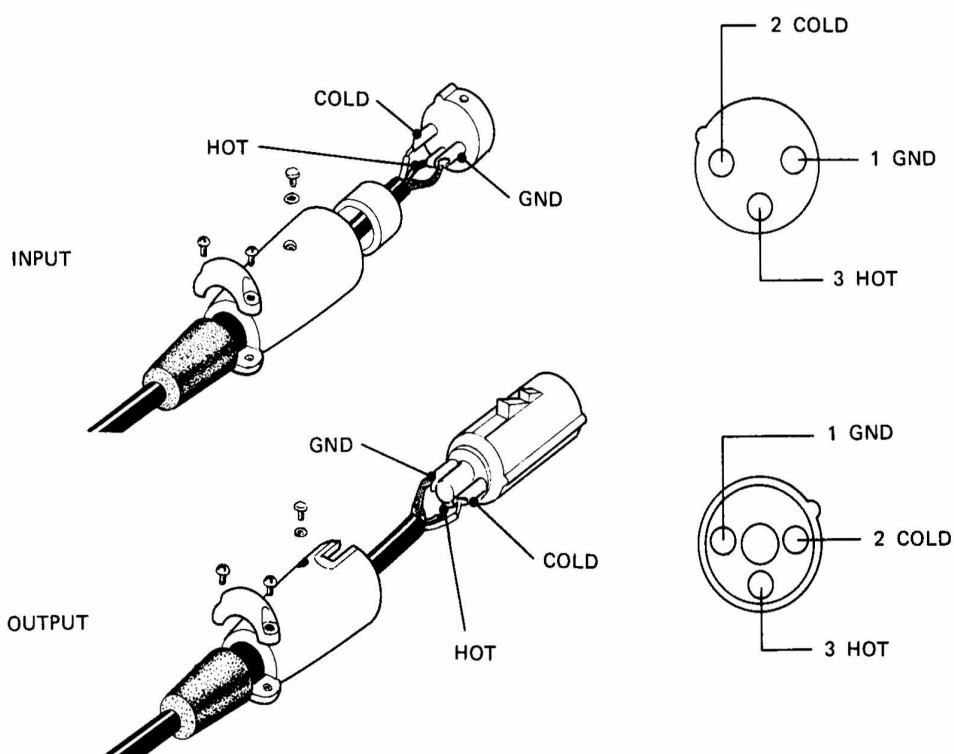

Figure 6-9 Balanced Input and Output Connector Wiring

NOTE: To avoid ground loop induced hum, it is a good practice to follow a single point grounding plan, in which the cable shields are connected only at one end (usually at the console) and a single ground or drain wire connectors the tape machine to the mixing console.

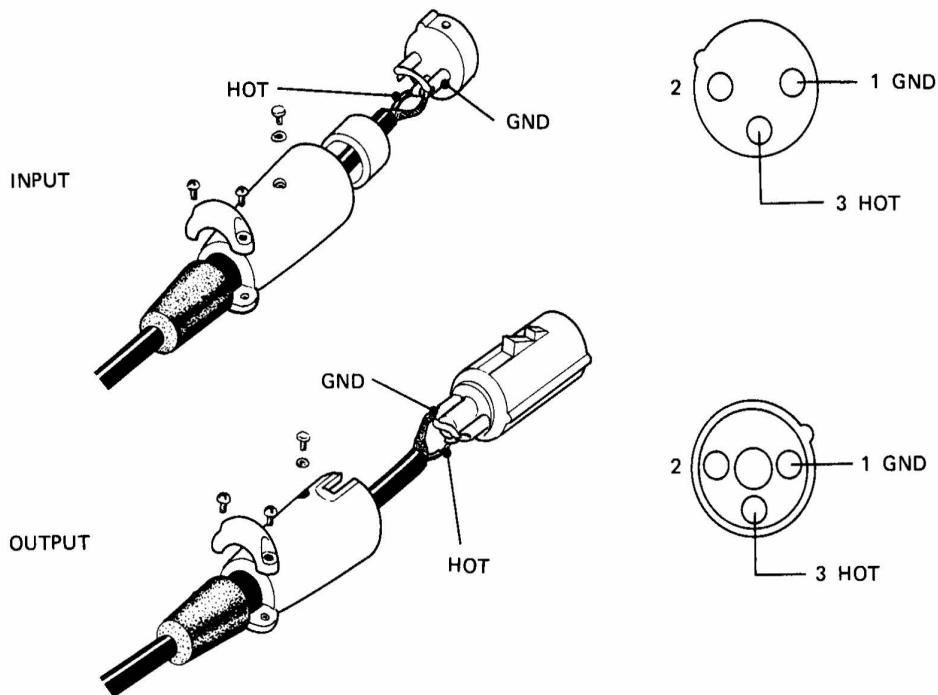

Figure 6-10 Unbalanced Input and Output Connector Wiring



## Section 6

## 6.3.3 Hooking up the Remote Control Unit (CB-123/-124)

Connect the MX-80 and the Remote Control Unit together by the cable supplied with the machine.

NOTE: Make sure the Power to the machine is turned off before connecting the Remote Control Unit to the MX-80.

Table 6-4 describes the pin assignments for the REMOTE CONTROL connector.

Table 6-4 Remote Control Connector Pin Assignments

| Pin No. | Description     | Pin No. | Description |
|---------|-----------------|---------|-------------|
| 1       | FRAME GND       | 16      | POWER       |
| 2 - 7   | N.C.            | 17      | POWER       |
| 8       | GND             | 18      | N.C.        |
| 9       | GND             | 19      | TACH PULSE  |
| 10      | TRANSMIT COMMON | 20      | N.C.        |
| 11      | TRANSMIT A      | 21      | FWD/REV     |
| 12      | RECEIVE B       | 22      | N.C.        |
| 13      | RECEIVE COMMON  | 23      | N.C.        |
| 14      | FRAME GND       | 24      | TRANSMIT B  |
| 15      | N.C.            | 25      | RECEIVE A   |

## 6.3.4 Using the Parallel I/O Connector

This 37-pin D-sub type connector is used to interface the optional CB-119 Locator, CB-120 series Locator or another synchronizer/controller to MX-80. The connector contains "tally" signals, indicating machine status, in addition to transport control, tachometer pulses, and capstan speed reference signals. Refer to Table 6-5 for a complete description of the signals and controls available at this connector.

Table 6-5 Parallel I/O Connector Pin Assignments

| Pin No. | Name           | Level | IN/OUT | Functions                   |
|---------|----------------|-------|--------|-----------------------------|
| 1       | REC SW         | Low   | ←      | RECORD SWITCH               |
| 2       | PLAY SW        | Low   | ←      | PLAY SWITCH                 |
| 3       | STOP SW        | Low   | ←      | STOP SWITCH                 |
| 4       | FF SW          | Low   | ←      | F.FWD SWITCH                |
| 5       | REW SW         | Low   | ←      | REWIND SWITCH               |
| 6       | LIFTER         | Low   | ←      | LIFTER DEFEAT<br>COMMAND    |
| 7       | 2nd FUNC SW    | Low   | ←      | 2nd FUNC SWITCH             |
| 8       |                |       |        |                             |
| 9       | SHUT OFF       | Low   | →      | SHUT OFF SWITCH             |
| 10      | REC TALLY      | Low   | →      | RECORD TALLY                |
| 11      | PLAY TALLY     | Low   | →      | PLAY TALLY                  |
| 12      | STOP TALLY     | Low   | →      | STOP TALLY                  |
| 13      | FF TALLY       | Low   | →      | F.FWD TALLY                 |
| 14      | REW TALLY      | Low   | →      | REWIND TALLY                |
| 15      | 2nd FUNC TALLY | Low   | →      | 2nd FUNC TALLY              |
| 16      | SIG-GND        | -     | -      | SIGNAL GROUND               |
| 17      | TACH           | -     | →      | TACH PULSE (Note 1)         |
| 18      | REV/FWD        | H/L   | →      | TAPE DIRECTION FWD<br>= LOW |
| 19      | 9.6K (FIX)     | -     | →      | CAPSTAN CLOCK               |
| 20      | CAPSTAN CLOCK  | -     | ←      | 9,600 Hz (Nom) In           |
| 21      | SPD-A          | H/L   | →      | TAPE SPEED A<br>(Note 2)    |

## Section 6

| Pin No. | Name                | Level | IN/OUT | Functions                        |
|---------|---------------------|-------|--------|----------------------------------|
| 22      | SPD-B               | H/L   | →      | TAPE SPEED B<br>(Note 2)         |
| 23      | PITCH ENABLE        | Low   | ←      | EXTERNAL PITCH<br>CONTROL ENABLE |
| 24      | PITCH TALLY         | Low   | →      | EXTERNAL PITCH<br>CONTROL TALLY  |
| 25      | AMP REC READY TALLY | Low   | →      | AMP REC READY TALLY              |
| 26      |                     |       |        |                                  |
| 27      |                     |       |        |                                  |
| 28      |                     |       |        |                                  |
| 29      |                     |       |        |                                  |
| 30      |                     |       |        |                                  |
| 31      |                     |       |        |                                  |
| 32      | REHEARSAL           | Low   | ←      | RECORD REHEARSAL<br>COMMAND      |
| 33      | +5V                 | ±10%  |        | REGULATED<br>(MAX 150 mA)        |
| 34      | +24V                |       |        | UNREGULATED<br>(MAX 500 mA)      |
| 35      | +24V                |       |        | "                                |
| 36      | POWER GND           |       |        | POWER GROUND                     |
| 37      | POWER GND           |       |        | "                                |

## NOTE:

## 1. Output Tach Pulse Rate

| Tape Speed (ips) | SMPTE (pulse/sec) | EBU (pulse/sec) |
|------------------|-------------------|-----------------|
| 3.75             | 30                | 25              |
| 7.5              | 60                | 50              |
| 15               | 120               | 100             |
| 30               | 240               | 200             |

## 2. Tape speed is defined as follows.

| SPD-A | SPD-B | Tape Speed (ips) |
|-------|-------|------------------|
| L     | L     | 3.75             |
| L     | H     | 7.5              |
| H     | L     | 15               |
| H     | H     | 30               |

## 3. Type of Connector

D-sub 37-pin Female (OTARI Parts No.: CN237367)

## 4. Output Signal

Output Type : Open Collector

$V_{OL}$  : 0 - 0.5 V

$I_{OL}$  : 20 mA (MAX)

$V_{IL}$  : TTL Level



## Section 6

Leak Current : 20 uA (MAX)  
Pull Up : 10k ohm (Terminated to +5 V)  
 $V_{OH}$  (High Level): +30 V (MAX)

### 5. Input Signal

Fan-in : 1/5  
 $V_{IL}$  : 0 - 0.5 V (-2.4 mA)  
 $V_{IH}$  : 2.5 - 5.25 V (60 uA)

6. Cable Length : 10 m (32 ft)

7. Input Command Pulse Width: 10 mS (MIN)

8. Duty Cycle of Tach Pulse : 20 - 80%

### 6.3.5 Noise Reduction System Control

The NOISE REDUCTION connectors provide Input/Repro switching signals to control the Encode/Decode modes of a remote noise reduction unit such as Dolby "A" or dbx 216. Simultaneous Encode/Decode systems such as dbx 180 or dbx 208 do not require connection to the MX-80 switching. Refer to Table 6-6 for pin assignments for these connectors. The MX-80 provides a "dry-contact" closure for each channel. This contact is closed when that channel is in Record or Input mode, and is open when the channel is in Sel-Rep, or Repro modes. Some noise reduction units may require logic level signals to function properly. In this case you must provide any logic voltage supply and any external connections required.

Table 6-6 Noise Reduction Control Connector  
Pin Assignments

| Channel | Pins  | Channel | Pins  |
|---------|-------|---------|-------|
| 1       | 1-2   | 17      | 1-2   |
| 2       | 3-4   | 18      | 3-4   |
| 3       | 5-6   | 19      | 5-6   |
| 4       | 7-8   | 20      | 7-8   |
| 5       | 9-10  | 21      | 9-10  |
| 6       | 11-12 | 22      | 11-12 |
| 7       | 13-14 | 23      | 13-14 |
| 8       | 15-16 | 24      | 15-16 |
| 9       | 19-20 | 25      | 19-20 |
| 10      | 21-22 | 26      | 21-22 |
| 11      | 23-24 | 27      | 23-24 |
| 12      | 25-26 | 28      | 25-26 |
| 13      | 27-28 | 29      | 27-28 |
| 14      | 29-30 | 30      | 29-30 |
| 15      | 31-32 | 31      | 31-32 |
| 16      | 33-34 | 32      | 33-34 |

Contacts are closed when channel is Input or Record mode;  
contacts are open in Repro and Sel-Rep modes.

## Section 6

## 6.3.6 Serial I/O (Optional)

A pair of optional interface PCBs are available that allow control of the MX-80 transport functions through a serial interface meeting RS-232C or RS-422 (SMPTE/EBU) interface standards. The baud rates of the serial data is selectable by switches on the PCB. The baud rates available for the RS-232C interface are 110, 1200, 2400, and 4800. The baud rates available for the RS-422 (SMPTE/EBU) interface are 9600, 19,200, and 38,400. Contact OTARI for a list of the ASCII codes used for function control.

Table 6-7 Serial I/O Connector Pin Assignments

## RS-232C SERIAL PORT

| No. | Name      | IN/OUT | Function        |
|-----|-----------|--------|-----------------|
| 1   | FRAME GND | -      | FRAME GROUND    |
| 2   | TXD       | ←      | TRANSMIT DATA   |
| 3   | RXD       | →      | RECEIVE DATA    |
| 4   | RTS       | ←      | REQUEST TO SEND |
| 5   | CTS       | →      | CLEAR TO SEND   |
| 6   | DSR       | →      | DATA SET READY  |
| 7   | SGND      | -      | SIGNAL GROUND   |
| 8   |           |        |                 |
| 9   |           |        |                 |
| 10  |           |        |                 |
| 11  |           |        |                 |
| 12  |           |        |                 |
| 13  |           |        |                 |
| 14  |           |        |                 |
| 15  |           |        |                 |
| 16  |           |        |                 |

| No. | Name | IN/OUT | Function            |
|-----|------|--------|---------------------|
| 17  |      |        |                     |
| 18  |      |        |                     |
| 19  | TACH | →      | TACH PULSE          |
| 20  | DTR  | ←      | DATA TERMINAL READY |
| 21  |      |        |                     |
| 22  |      |        |                     |
| 23  |      |        |                     |
| 24  |      |        |                     |
| 25  |      |        |                     |

NOTE 1. I/O specification conform to EIA-RS232C

NOTE 2. Baud Rate: 2.4k - 19.2k (110 - 1200 Baud is option)

NOTE 3. Type of Connector: D-sub 25 Female (System side)

#### SMPTE/EBU BUS (RS-422) SERIAL PORT

| NO. | NAME      | IN/OUT | FUNCTION        |
|-----|-----------|--------|-----------------|
| 1   | FRAME GND | -      | FRAME GROUND    |
| 2   | TXD A     | →      | TRANSMIT A      |
| 3   | TXD B     | ←      | RECEIVE B       |
| 4   | R. COM    | -      | RECEIVE COMMON  |
| 5   | TACH      | →      | TACH PULSE      |
| 6   | T. COM    | -      | TRANSMIT COMMON |
| 7   | TXD B     | →      | TRANSMIT B      |



Section 6

| NO. | NAME      | IN/OUT | FUNCTION     |
|-----|-----------|--------|--------------|
| 8   | RXD A     | ←      | RECEIVE A    |
| 9   | FRAME GND | -      | FRAME GROUND |

NOTE 1. I/O specification conform to SMPTE/EBU BUS (RS-422A)

NOTE 2. Baud Rate: 2.4k - 38.4k Baud

NOTE 3. Type of Connector: D-sub 9 Female (System side)

#### 6.4 LEVEL MATCHING

It is important that the input and output level of the mixing console match those of the tape recorder, to insure the best balance of headroom and signal-to-noise ratio. The input and output levels of the MX-80 are switch selectable to match systems using either +4 dBm or -10 dBV signal levels.

NOTE: The MX-80 reference level and VU meter calibration must be adjusted properly in accordance with the instructions in Section 4 before proceeding with level matching.

Thread the machine with a reel of the tape normally used for sessions.

- (1) Determine the nominal input and output levels of your mixing console. This can usually be found in the specifications section of the mixing console instruction manual.
- (2) Set the Input and Output Level switches (SW5 and SW4 respectively) on the Audio Control PCB to match the mixing console input and output levels.
- (3) Using the mixing console's test oscillator, or an external test oscillator connected to one of the mixing console's inputs, adjust the mixing console controls so that the console's output VU meter reads 0 VU.
- (4) Extend the MX-80's CH1 Audio Amplifier PCB.

- (5) Patch or route the test signal to the MX-80's CH1 INPUT connector.
- (6) Press the ALL INPUT button on the Remote Control Unit, and adjust the Input trimmer (VR14) on the CH1 Audio Amplifier PCB until the CH1 VU meter indicates 0 VU.
- (7) Connect the oscillator to the TEST SIGNAL input on the Audio Control PCB, press the ALL INPUT button on the Remote Control Unit, and adjust the Test Signal trimmer (VR13) on the Audio Amplifier PCB until the CH1 VU meter reads 0 VU.
- (8) Repeat Steps 4 through 7 for all remaining channels.
- (9) Press the PLAY and RECORD buttons to place the transport in Record mode.
- (10) Record several minutes of signal.
- (11) Rewind the tape, and press the ALL REPRO button.
- (12) Press the PLAY button.
- (13) Put the mixing console into "mix-down" mode or connect the CH1 OUTPUT connector to a mixing console line input.
- (14) Adjust the mixing console input trim control so that the channel fader will reach the desired position when the mixing console VU meter indicates 0 VU.

SECTION 7: SPECIFICATIONS

7.1 TAPE TRANSPORT

TRACK CONFIGURATION : MX-80-32-H, -32-L  
2" (50.8 mm) wide tape  
32 channel

MX-80-24/32-H, -24/32-L  
MX-80-24-H, -24-L  
2" (50.8 mm) wide tape  
24 channel

MX-80-16-H, -16-L  
2" (50.8 mm) wide tape  
16 channel

TAPE SPEEDS : Switchable for speed version  
change.

High speed version:  
30 ips (76.2 cm/s)  
15 ips (38.1 cm/s)

Low speed version:  
15 ips (38.1 cm/s)  
7.5ips (19.05 cm/s)

FAST WIND TIME : 80 sec for 2,500 ft

REEL SIZE : 10-1/2" diameter (26.8 cm)

HEADS : Plug-in head blocks with full  
access to independent head  
azimuth adjustment.

MOTORS : Capstan Motor:  
Servo controlled  
Quartz PLL  
Direct drive DC motor

Reel Motor:  
CPU controlled  
Tension servo DC motor

LIBRARY WIND SPEED : 120 ips

FAST WIND SPEED : 450 ips

PITCH CONTROL :  $\pm$  50% continuously variable  
control.

Section 7

EXTERNAL SPEED CONTROL RANGE : 30 ips = + 50 - -50%  
15 ips = +100 - -50%  
7.5ips = +100 - -50%

START TIME : Play

30 ips ... Less than 0.8 sec.  
15 ips ... Less than 0.6 sec.  
7.5ips ... Less than 0.5 sec.

Fast Wind  
Less than 8 sec.

STOP TIME : Play

30 ips ... Less than 0.7 sec.  
15 ips ... Less than 0.6 sec.  
7.5ips ... Less than 0.5 sec.

Fast Wind  
Less than 5 sec.

TAPE SPEED ACCURACY :  $\pm 0.1$  %

TAPE SPEED DEVIATION : Within 0.07 %

WOW & FLUTTER : CCIR (DIN) WTD. 2 $\sigma$

30 ips ... Less than  $\pm 0.04$  %  
15 ips ... Less than  $\pm 0.06$  %  
7.5ips ... Less than  $\pm 0.08$  %

SWITCHES : F.FWD, REWIND, STOP, PLAY,  
RECORD, 2nd FUNC, CUE,  
EDIT/UNLOAD, SPEED SELECT,  
SEARCH ZERO, SEARCH 1 - 3,  
SET, CLR, REPEAT, TIME-IPS-%

TAPE TIME COUNTER : Five digit LED readout from  
tachometer/logic measurement  
circuit; indicates tape time  
in hours, minutes, and  
seconds.

7.2 ELECTRONICS

NOTE: All specifications are measured with AMPEX 456.

LINE INPUT : Active balanced (transformerless),  
10k ohm impedance, Input level  
+4/-8 dBm switchable, maximum  
+30 dBm

LINE OUTPUT : Active balanced, BAL/UNBAL switch-  
able, Less than 5 ohm source  
impedance, +4 dBm output for 0 VU,  
maximum +28 dBm

LINE OUTPUT (THROUGH : BAL/UNBAL switchable  
FRONT PANEL JACK) 1k ohm source impedance

EQUALIZATION : 30 ips ... AES  
15 ips ... IEC or NAB switchable  
7.5ips ... IEC or NAB switchable

BIAS FREQUENCY : 192 kHz

ERASE FREQUENCY : 192 kHz

CALIBRATION LEVELS : Switchable, 320 nWb/m or 250 nWb/m

PEAK INDICATOR LEVEL : 1040 nWb/m adjustable

FREQUENCY RESPONSE : Overall (24ch)

|        |            |            |
|--------|------------|------------|
| 30 ips | 50 - 22kHz | $\pm 2$ dB |
| 15 ips | 30 - 20kHz | $\pm 2$ dB |
| 7.5ips | 20 - 18kHz | $\pm 2$ dB |

Overall (32ch)

|        |            |            |
|--------|------------|------------|
| 30 ips | 60 - 22kHz | $\pm 2$ dB |
| 15 ips | 35 - 20kHz | $\pm 2$ dB |
| 7.5ips | 25 - 18kHz | $\pm 2$ dB |

Rec/Sel-Rep (24/32ch)

|        |            |            |
|--------|------------|------------|
| 30 ips | 60 - 22kHz | $\pm 2$ dB |
| 15 ips | 35 - 20kHz | $\pm 2$ dB |
| 7.5ips | 25 - 18kHz | $\pm 2$ dB |

DISTORTION : Less than 0.3% at 1 kHz 320 nWb/m

CROSSTALK : More than 52 dB at 1 kHz (32ch)  
More than 55 dB at 1 kHz (24ch)



Section 7

DEPTH OF ERASURE : More than 75dB

SIGNAL-TO-NOISE RATIO : Unweighted with audio filter  
(30 Hz - 18 kHz) at 320 nWb/m

|        | 32ch  |       | 24ch  |       |
|--------|-------|-------|-------|-------|
|        | IEC   | AES   | IEC   | AES   |
| 30 ips | ---   | 56 dB | ---   | 57 dB |
| 15 ips | 56 dB | 54 dB | 57 dB | 55 dB |
| 7.5ips | 54 dB | 56 dB | 55 dB | 57 dB |

7.3 PHYSICAL

POWER REQUIREMENTS : 100, 117, 200 or 240 volts  
Single phase AC, 50 or 60 Hz  
550 VA (24ch)  
700 VA (32ch)

OPERATING ENVIRONMENT : 40° to 104°F (5° to 40°C),  
20 - 80% RH

STORAGE ENVIRONMENT : -5° to 113°F (-20° to 45°C),  
20 - 80% RH

MOUNTING : All models are in floor console.

WEIGHT : 135 kg (32ch)  
3 kg (Remote)

DIMENSIONS (W x D x H): 640 x 658 x 1080

7.4 ACCESSORIES

STANDARD : Remote Control Unit with cable ass'y  
(CB-123 or CB-124), Operating  
Manual, Fuses, Power Cable, Lamps

OPTIONAL : PB-7JEA

OTARI reserves the right to change the specifications without  
notice or obligation.

## SECTION 8: PARTS LISTS AND P.C.B. ASSEMBLIES

8.1 GENERAL

The following P.C.B. pattern layout drawings and parts lists are provided for service reference. Parts list includes only main parts or the parts difficult to obtain in the field. Also the lists include the parts which should be replaced with the exact same parts supplied by OTARI to maintain the performance. Many diodes, transistors, and ICs are well described in the schematics attached to the machine, so to find out the correct parts number of those parts you need, refer to the schematics.

NOTE: In the parts lists, descriptions for capacitors have following meanings.

|             |  |
|-------------|--|
| F-capacitor | Maylar film type capacitor             |
| B-capacitor | Bympolar chemical capacitor            |
| P-capacitor | Polypropylen film capacitor            |
| M-capacitor | Mica capacitor                         |
| L-capacitor | Low leakage current chemical capacitor |
| T-capacitor | Tantalum electrolytic capacitor        |

NOTE: Ref. No. for the parts which are many used on a PCA such as capacitor diode, transistor and IC are only few given in the lists instead of being described all.

8.2 PARTS LISTS

You will find drawings for the following P.C.B.s in this section.

## MX-80 P.C.B. ASSEMBLIES

| <u>Ref. No.</u> | <u>Description</u>                    | <u>Parts No.</u> |
|-----------------|---------------------------------------|------------------|
| 1               | Capstan Control P.C.B. Assembly       | PB-4FAA          |
| 2               | Reel Control P.C.B. Assembly          | PB-4FBA          |
| 3               | Reel Drive P.C.B. Assembly            | PB-4FCA          |
| 4               | Transport Control P.C.B. Assembly     | PB-4FDA          |
| 5               | Serial Remote Control P.C.B. Assembly | PB-4FEA          |
| 6               | Audio Control P.C.B. Assembly         | PB-4FFA          |
| 7               | Audio Amplifier P.C.B. Assembly       | PB-19JA          |
| 8               | Power Supply P.C.B. Assembly          | PB-62ZA          |
| 9               | Display P.C.B. Assembly (24CH)        | PB-7JAB          |
| 10              | CPU P.C.B. Assembly                   | PB-4FGA          |

## Section 8

[1]: PB-4FAA CAPSTAN CONTROL P.C.B. ASSEMBLY

| <u>Ref. No.</u> | <u>Description</u> | <u>Parts No.</u> | <u>Notes</u> |
|-----------------|--------------------|------------------|--------------|
| IC10,15-17      | IC                 | I-0067           |              |
| D1              | LED                | PNSLP520         | Red/Blue     |
| D3,5,7          | Diode              | PN-0230          |              |
| D4,6            | Diode              | PN-0038          | 12V          |
| D9              | Diode              | PNVD1222         |              |
| D10             | Diode              | PN-0026          | 8.2V         |
| Q6-14           | Transistor         | Q-0008           |              |
| L1,2            | Inductor           | IN19073          | 470uH        |
| VR1-6           | Potentiometer      | RV414312         | 10k          |
| VR7             | Potentiometer      | RV453206         | 5k           |
| R80             | Resistor           | R8CJ621M         | 620 ohm 2W   |
| R92             | Resistor           | R8CJ101M         | 100 ohm 2W   |
| C3              | B-Capacitor        | C11R067M         | 50V/1        |
| C4,19           | B-Capacitor        | C110062M         | 25V/10u      |
| C6              | F-Capacitor        | CFF3471          | 50V/470pF    |
| C9              | F-Capacitor        | CFF3563          | 50V/0.056uF  |
| C10             | F-Capacitor        | CFF3103          | 50V/0.1uF    |
| C12             | B-Capacitor        | C133053M         | 10V/33u      |
| C22             | F-Capacitor        | CFF3333          | 50V/0.33uF   |
| RL1             | Relay              | RY1DC081         | 24V          |
| RL2             | Relay              | RY1DC051         | DC24V        |
| CP1             | Check Pin          | CN901149         | Red          |
| CP5,6           | Check Pin          | CN901157         | Black        |
| CN1             | Connector          | CN408356         | 8P           |
| CN2             | Connector          | CN402350         | 2P           |
| CN3             | Connector          | CN411379         | 11P          |
| CN4             | Connector          | CN410358         | 10P          |
| CN5             | Connector          | CN409357         | 9P           |
| CN6             | Connector          | CN402306         |              |

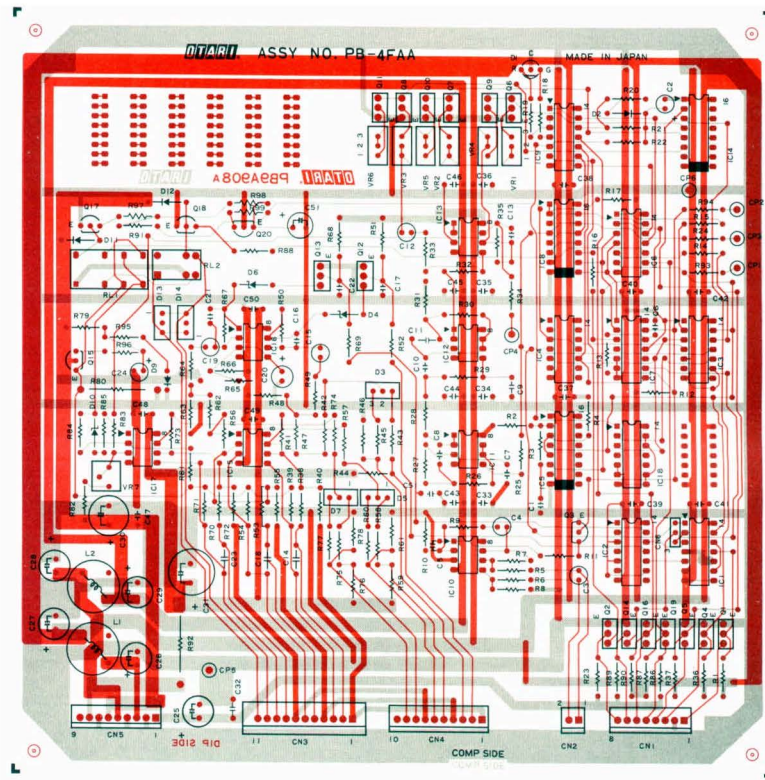



[2] : PB-4FAB REELCONTROL P.C.B. ASSEMBLY

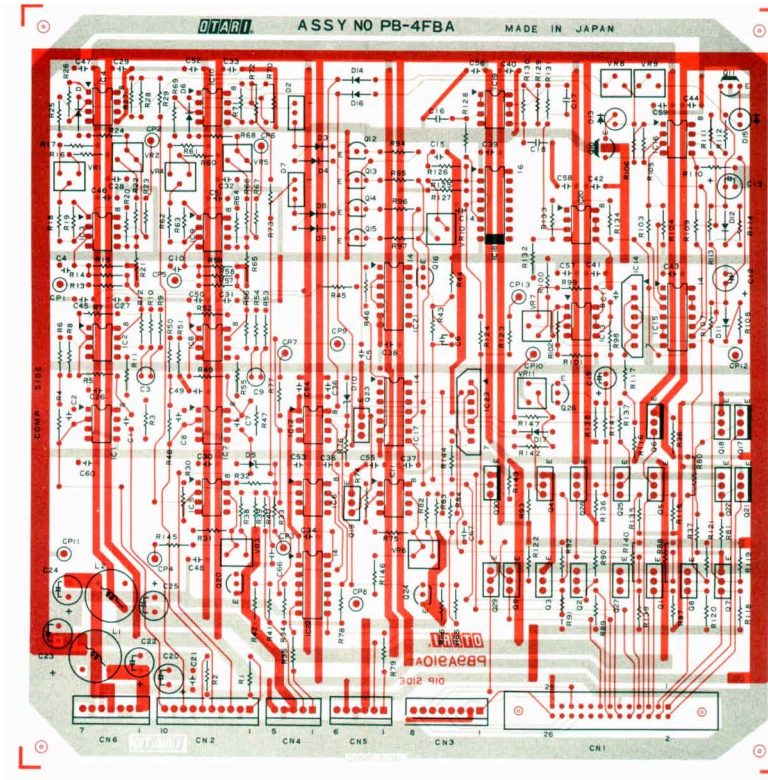



## [2]: PB-4FBA REEL CONTROL P.C.B. ASSEMBLY

| <u>Ref. No.</u> | <u>Description</u> | <u>Parts No.</u> | <u>Notes</u> |
|-----------------|--------------------|------------------|--------------|
| IC14,23         | IC                 | I-0053           |              |
| D1,3,5          | LED                | PNTLR124         | Red          |
| D2,7            | Diode              | PN-0230          |              |
| D5,18           | Diode              | PN-0035          |              |
| Q1-5            | Transistor         | Q-0008           |              |
| Q6,17           | Transistor         | Q-0004           |              |
| L1,2            | Inductor           | IN19073          | 470uH        |
| VR1,2           | Potentiometer      | RV414207         | 10k          |
| VR3,6           | Potentiometer      | RV453206         | 5k           |
| VR8,9           | Potentiometer      | RV454210         | 50k          |
| VR11            | Potentiometer      | RV415257         | 100k         |
| C1              | F-Capacitor        | CFF3102          | 50V/0.001uF  |
| C3,9            | B-Capacitor        | C110052M         | 16V/10uF     |
| C4              | F-Capacitor        | CFF3103          | 50V/0.01uF   |
| C5              | P-Capacitor        | CGI3151          | 100V/150pF   |
| C15             | F-Capacitor        | CFF3472          | 50V/0.0047uF |
| CP1             | Check Pin          | CN901149         | Red          |
| CP11,12         | Check Pin          | CN901157         | Black        |
| CN1             | Connector          | CN326220         | 26P          |
| CN2             | Connector          | CN410358         | 10P          |
| CN3             | Connector          | CN408356         | 8P           |
| CN4             | Connector          | CN405353         | 5P           |
| CN5             | Connector          | CN406254         | 6P           |
| CN6             | Connector          | CN407355         | 7P           |

Section 8

[3]: PB-4FCA REEL DRIVE P.C.B. ASSEMBLY

| <u>Ref. No.</u> | <u>Description</u>  | <u>Parts No.</u> | <u>Notes</u> |
|-----------------|---------------------|------------------|--------------|
| D3,4            | Diode, Zener        | PN1Z18           |              |
| D5              | Diode               | PNMA650          |              |
| Q3,4            | Insulator           | PZ4B068          |              |
| Q7              | Insulator           | PZ4B055          |              |
| L1,2            | Ferite Core         | PZ4Z003          |              |
| L3,4            | Inductor            | IN19080          | 140uH        |
| R12,13          | Resistor            | R4DKR22M         | 0.22 ohm 7W  |
| C2              | F-Capacitor         | CFF3102          | 50V/0.001uF  |
| CN1             | Connector           | CN405353         | 5P           |
| CN2             | Connector, Header   | CN402081         | 2P           |
| CN3             | Connector, S Header | CN404083         | 4P           |
|                 | Heat Sink           | CB73802          |              |



[4] : PB-4FDA TRANSPORT CONTROL P.C.B. ASSEMBLY

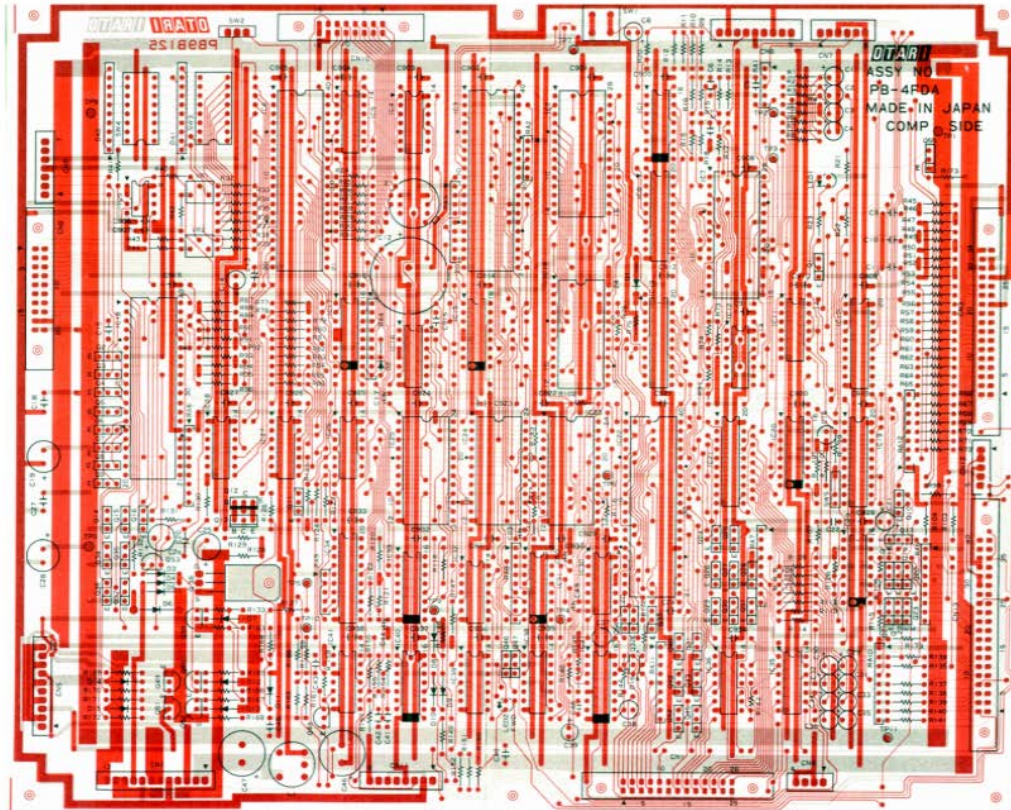

## [4]: PB-4FDA TRANSPORT CONTROL P.C.B. ASSEMBLY

| <u>Ref. No.</u> | <u>Description</u> | <u>Parts No.</u> | <u>Notes</u> |
|-----------------|--------------------|------------------|--------------|
| IC7             | IC                 | I-0112           |              |
| IC9             | IC                 | I-0002           |              |
| IC14            | IC                 | I-0075           |              |
| DA1,2           | Diode Array        | PNNAL8CS         |              |
| Q1,10           | Transistor         | Q-0008           |              |
| Q2,9            | Transistor         | Q-0011           |              |
| L1              | Inductor           | IN19069          | 470uH        |
| VR1             | Potentiometer      | RV424208         | 20k          |
| VR2             | Potentiometer      | RV414207         | 10k          |
| RA2             | Resistor Array     | R94-079          | 10k x4       |
| RA3             | Resistor Array     | R94-132          | 4.7k x8      |
| RA4             | Resistor Array     | R94-136          | 10k x8       |
| C12             | Capacitor          | C1105184         | 5V/1F        |
| C42             | F-Capacitor        | CFF3103          | 50V/0.01uF   |
| C900            | F-Capacitor        | CFF3223          | 50V/0.022uF  |
| TP5             | Check Pin          | CN901150         | Orange       |
| TP11            | Check Pin          | CN901157         | Black        |
| CN1             | Connector          | CN326220         | 26P          |
| CN2             | Connector          | CN412380         | 12P          |
| CN3             | Connector          | CN334222         | 34P          |
| CN4             | Connector          | CN404352         | 4P           |
| CN5             | Connector          | CN410358         | 10P          |
| CN7             | Connector          | CN406354         | 6P           |
| CN8             | Connector          | CN320219         | 20P          |
| CN9             | Connector          | CN407355         | 7P           |
| CN10            | Connector          | CN316218         | 16P          |
| CN11            | Connector          | CN408356         | 8P           |
| CN12            | Connector          | CN405353         | 5P           |
| CN13            | Connector          | CN340223         | 40P          |
| CN16            | Connector          | CN409357         | 9P           |
| LED1            | LED                | PNTLG124         | Green        |
| LED2            | LED                | PNLN2G           |              |
| SW1             | Switch             | WH0B104R         | Red          |
| SW1             | Switch             | WH11181          | Reset        |
| SW2             | Switch             | WH31031          | H/L          |
| SW3,4           | Switch             | WH98012          | Dip          |
| SW5             | Switch             | WH91023          |              |
| X1              | Crystal            | PZ4C021          | 6.144MHz     |



## Section 8

## [5]: PB-4FEA SERIAL REMOTE CONTROL AMPLIFIER P.C.B. ASSEMBLY

| <u>Ref. No.</u> | <u>Description</u> | <u>Parts No.</u> | <u>Notes</u> |
|-----------------|--------------------|------------------|--------------|
| IC19            | IC                 | I-0021           |              |
| Q1,15-          | Transistor         | Q-0008           |              |
| Q16,19          | Transistor         | Q-0004           |              |
| L1              | Inductor           | IN19069          | 470uH        |
| RA1             | Resistor Array     | R94-136          | 10k x8       |
| RA7             | Resistor Array     | R94-079          | 10k x4       |
| C37             | F-Capacitor        | CFF3103          | 50V/0.01uF   |
| CP0,1           | Connector          | CN901157         | Black        |
| CP2             | Connector          | CN901150         | Orange       |
|                 | Connector          | CN402328         | 2P for LED   |
| CN1             | Connector          | CN3A0305         |              |
| CN2             | Connector          | CN412409         | 12P          |
| CN              | Connector          | CN402306         | 2P           |
| CN              | Connector          | CN403310         | 3P           |
| CN26            | Connector          | CN628152         | 28P          |
| CN27            | Connector          | CN640153         | 40P          |
| LED1,10,19      | LED                | PNTLR124         | Red          |
| LED2,7,9        | LED                | PNLN2G           |              |
| LED8            | LED                | PNTLG124         | Green        |
| LED1-10         | LED                | PNTLO124         | Orange       |
| SW1             | Switch             | WH0B104R         | Red          |
| SW1             | Switch             | WH11181          |              |
| SW2,8           | Switch             | WH91023          |              |
| SW3             | Switch             | WH11253          |              |
| SW4             | Switch, Slide      | WH31032          |              |
| SW5             | Switch             | WH360441         |              |
| SW6,7           | Switch             | WH360431         |              |
| SW9,10          | Switch             | WH98012          |              |
| SW11,12         | Switch, Dip        | WH91058          |              |
| X1              | Crystal            | PZ4C033          |              |
| X2              | Crystal            | PZ4C017          |              |
|                 | Card Puller        | PZ4E068          |              |
|                 | Dress Panel        | PB4FE01          |              |
|                 | Shield Plate       | ZA-93F           |              |

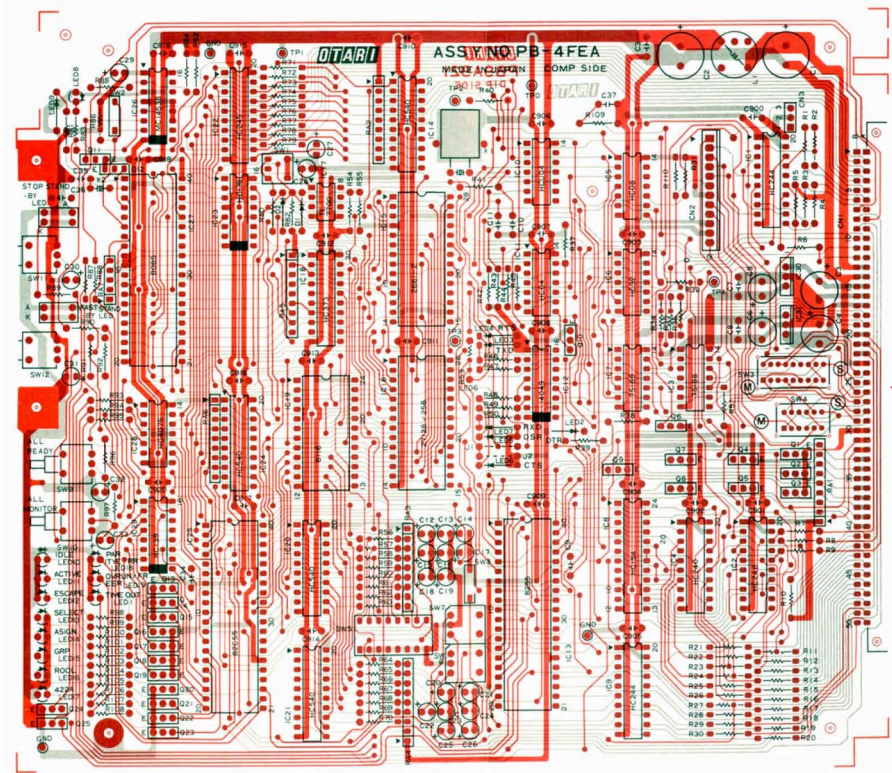

[6] : PB-4FFA AUDIO CONTROL P.C.B. ASSEMBLY

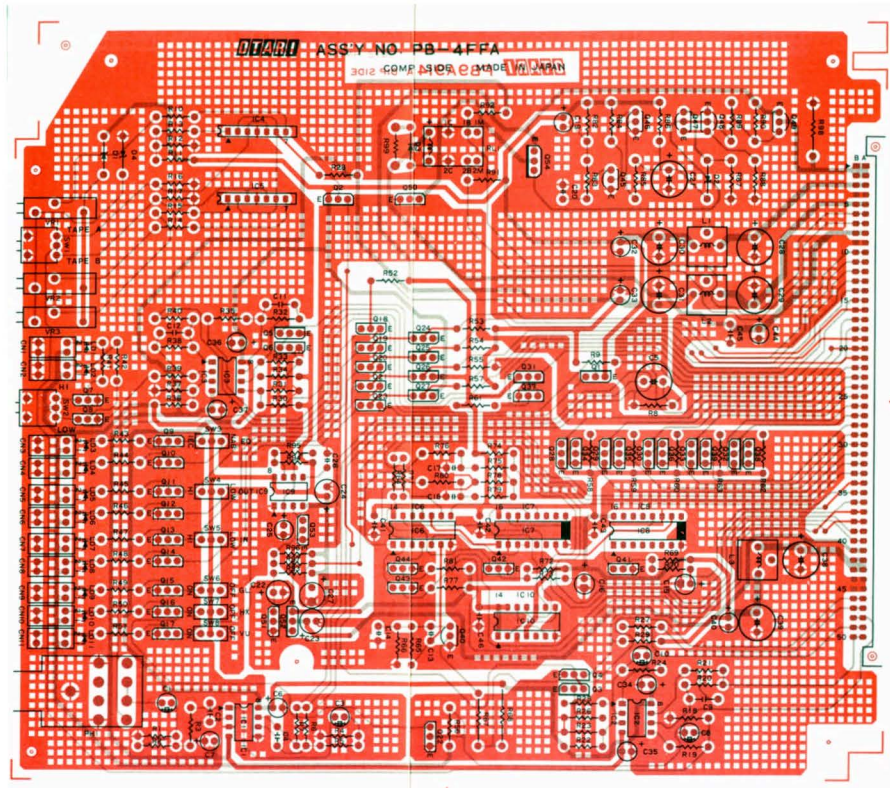

## [6]: PB-4FFA AUDIO CONTROL P.C.B. ASSEMBLY

| <u>Ref. No.</u> | <u>Description</u> | <u>Parts No.</u> | <u>Notes</u> |
|-----------------|--------------------|------------------|--------------|
| IC1-3           | IC                 | I-0067           |              |
| IC4,5           | IC                 | I-0053           |              |
| D1              | Diode              | PN-0011          |              |
| Q1-3            | Transistor         | Q-0004           |              |
| Q6-23           | Transistor         | Q-0008           |              |
| L1-3            | Inductor           | IN19078          | 470uH        |
| VR1-3           | Potentiometer      | RV454174         | 50k          |
| C1              | B-Capacitor        | C14R761M         | 25V/4.7      |
| C5              | B-Capacitor        | C110165M         | 25V/100      |
| C13             | F-Capacitor        | CFF3222          | 50V/0.0022uF |
| C14             | F-Capacitor        | CFF3822          | 50V/0.0082uF |
| RL1             | Relay              | RY2DC089         |              |
| SW1,2           | Switch, Slide      | WH31032          |              |
| SW3-8           | Switch             | WH31022          |              |
| LD1-17          | LED                | PNTL0124         | Orange       |
| CN1-10          | Connector          | CN402328         |              |
| PH1             | Connector          | CN601174         |              |
|                 | Dress Panel        | PB4FF01          |              |
|                 | Card Puller        | PZ4E068          |              |



## Section 8

## [7]: PB-19JA AUDIO AMPLIFIER P.C.B. ASSEMBLY

| <u>Ref. No.</u> | <u>Description</u> | <u>Parts No.</u> | <u>Notes</u>    | <u>Ref. No.</u> | <u>Description</u> | <u>Parts No.</u> | <u>Notes</u> |
|-----------------|--------------------|------------------|-----------------|-----------------|--------------------|------------------|--------------|
| IC1-6           | IC                 | I-0067           |                 | C104            | P-Capacitor        | CGI3621          | 100V/ 620pF  |
| IC7             | IC                 | I-0125           | Line Out Amp.   | C106            | F-Capacitor        | C3334169         | 50V/0.33u 2% |
| IC8             | IC                 | ITC9164N         |                 | C115            | P-Capacitor        | CGI3471          | 100V/ 470pF  |
| IC9             | IC                 | I-0133           |                 | C123            | P-Capacitor        | CGI3182          | 100V/1800pF  |
| IC11            | IC                 | I-0053           | Analog Switch   | C134            | B-Capacitor        | C122077M         | 25V/22uF     |
| IC21,29         | IC                 | I-0051           | Analog Switch   | C137            | P-Capacitor        | CGI3821          | 100V/ 820pF  |
| IC22            | IC                 | ITC9163N         |                 | C138            | P-Capacitor        | CGP3681S         | 630V/ 680pF  |
| IC24            | IC                 | I-0126           |                 | C169            | P-Capacitor        | CGP3332S         | 630V/3300pF  |
| IC33            | IC                 | I-0056           | Mode Controller | C175            | T-Capacitor        | C71R012M         | 35V/1        |
| D6-             | Diode              | PN-0011          |                 | RL1,3           | Relay              | RY1DC051         | DC24V        |
| D14             | Diode              | PN-0044          |                 | RL2             | Relay              | RY2DC089         |              |
| Q3              | Transistor         | Q-0008           |                 | SW1             | Switch             | WH31022          | BAL/UNBAL    |
| Q6              | Transistor         | Q-0004           |                 | SW2             | Switch             | WH98095          | DIP          |
| L1,4            | Inductor           | IN19085          | 1.8MH           | CP3             | Connector          | CN901150         | Orange       |
| L2,3            | Inductor           | IN19112          |                 | CP7,8           | Connector          | CN901157         | Black        |
| L5              | Inductor           | IN19123          | 1MH             | CN              | Connector          | CN3A0305         | 50P DIN      |
| VR1,2           | Potentiometer      | RV454285         | 50k             | LD1             | LED                | PNTLY124         | Yellow       |
| VR3-5           | Potentiometer      | RV424284         | 20k             | LD2             | LED                | PNTLG124         | Green        |
| VR11-14         | Potentiometer      | RV424297         | 20k             | LD3             | LED                | PNTLO124         | Orange       |
| VR21            | Potentiometer      | RV454174         | 50k             | TF1,2           | Transformer        | TF31022          | Bias         |
| VR22,23         | Potentiometer      | RV413293         | 1k              | J1              | Register           | PZ4E001          | 0 ohm        |
| R1              | Resistor Array     | R94-091          | 100k x4         |                 | Stud               | KZ71A101         | for LED      |
| R2              | Resistor Array     | R94-095          | 220k x4         |                 |                    |                  |              |
| R4              | Resistor Array     | R94-144          | 47k x8          |                 |                    |                  |              |
| R29             | Resistor           | R7HF1742         | 17.4k 1/4W 1%   |                 |                    |                  |              |
| R30             | Resistor           | R7HF3743         | 374k 1/4W 1%    |                 |                    |                  |              |
| R31             | Resistor           | R7HF2671         | 2.67k 1/4W 1%   |                 |                    |                  |              |
| R32             | Resistor           | R7HF6981         | 6.98k 1/4W 1%   |                 |                    |                  |              |
| R33             | Resistor           | R7HF1182         | 11.8k 1/4W 1%   |                 |                    |                  |              |
| R85             | Resistor           | R7HF752M         | 7.5k 1/4W 1%    |                 |                    |                  |              |
| R86             | Resistor           | R7HF912M         | 9.1k 1/4W 1%    |                 |                    |                  |              |
| R87             | Resistor           | R7HF203M         | 20k 1/4W 1%     |                 |                    |                  |              |
| R93             | Resistor           | R7HF182M         | 1.8k 1/4W 1%    |                 |                    |                  |              |
| R94             | Resistor           | R7HF7680         | 768 ohm 1/4W 1% |                 |                    |                  |              |
| R97             | Resistor           | R7HF392M         | 3.9k 1/4W 1%    |                 |                    |                  |              |
| R98             | Resistor           | R7HF273M         | 27k 1/4W 1%     |                 |                    |                  |              |
| R121            | Resistor           | R7HF103M         | 10k 1/4W 1%     |                 |                    |                  |              |
| R122            | Resistor           | R7HF332M         | 3.3k 1/4W 1%    |                 |                    |                  |              |
| R143            | Resistor           | R7HF104M         | 100k 1/4W 1%    |                 |                    |                  |              |
| R249            | Resistor           | R7AJ1ROM         | 1 ohm 1/2W 1%   |                 |                    |                  |              |
| C13             | L-Capacitor        | C110019M         | 25V/10uF        |                 |                    |                  |              |
| C23             | B-Capacitor        | C14R761M         | 25V/4.7         |                 |                    |                  |              |
| C26             | P-Capacitor        | CGI3271          | 100V/ 270pF     |                 |                    |                  |              |
| C33             | B-Capacitor        | C11R067M         | 50V/1           |                 |                    |                  |              |
| C38             | F-Capacitor        | C3103168         | 50V/0.01u 2%    |                 |                    |                  |              |
| C50             | B-Capacitor        | C110165M         | 25V/100uF       |                 |                    |                  |              |
| C66             | P-Capacitor        | CGI3391          | 100V/ 390pF     |                 |                    |                  |              |
| C72             | B-Capacitor        | C110062M         | 25V/10uF        |                 |                    |                  |              |



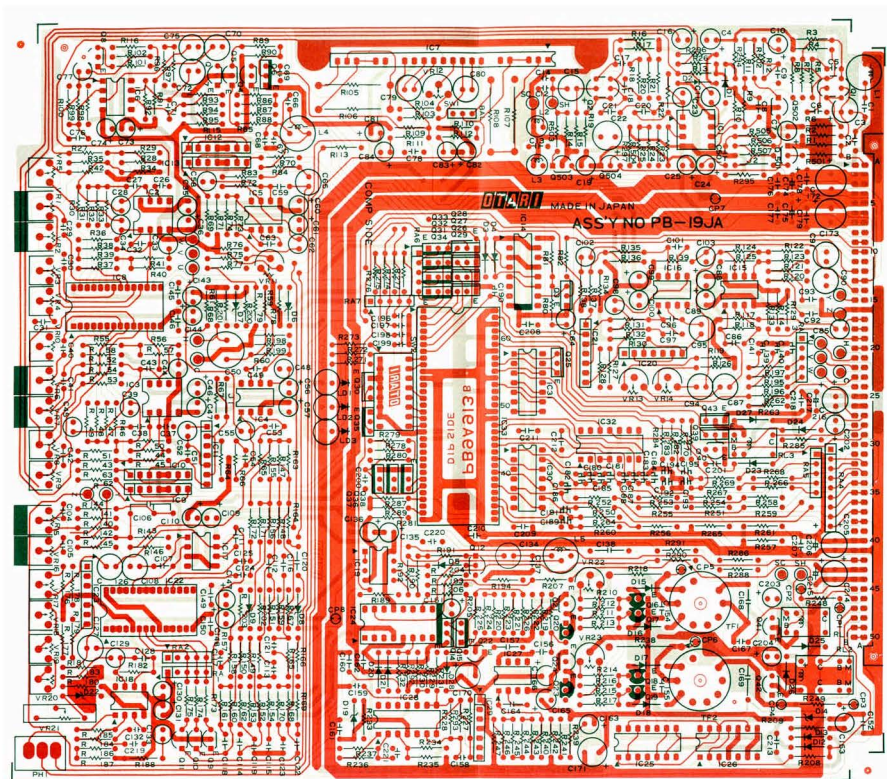

[8] : PB-62ZA POWER SUPPLY P.C.B. ASSEMBLY

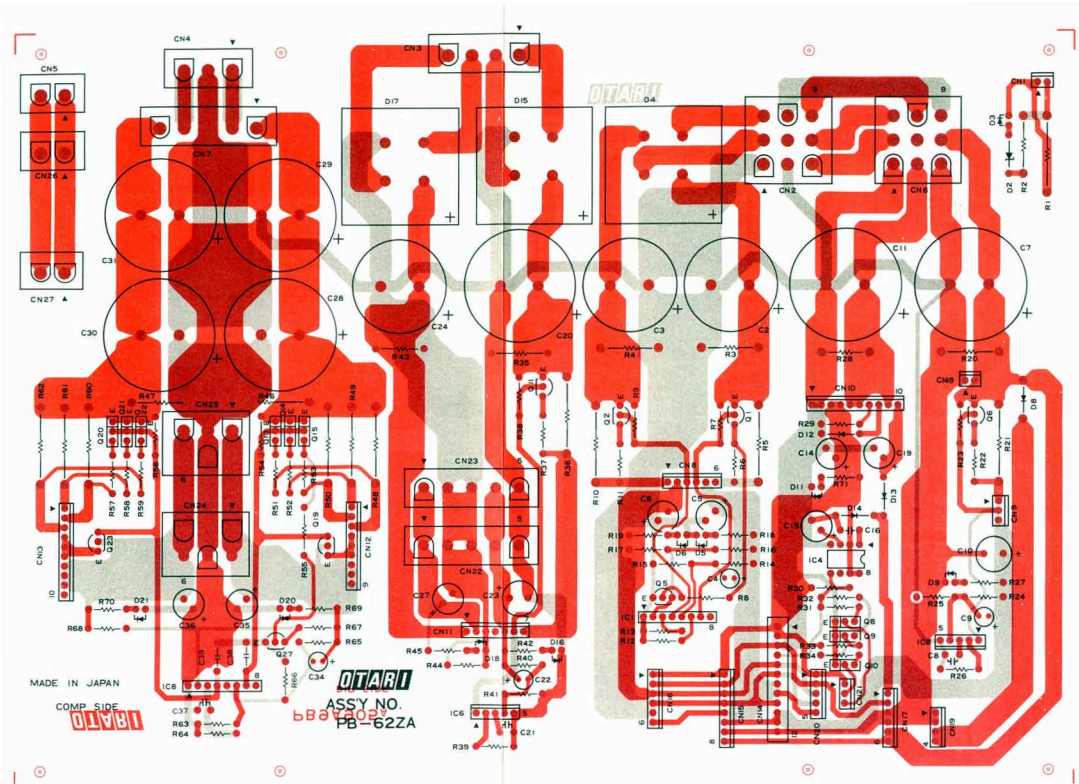

## [8]: PB-62ZA POWER SUPPLY P.C.B. ASSEMBLY

| <u>Ref. No.</u> | <u>Description</u>  | <u>Parts No.</u> | <u>Notes</u> |
|-----------------|---------------------|------------------|--------------|
| IC1,8           | IC                  | I-0062           |              |
| IC2,6           | IC                  | I-0063           |              |
| D2              | Diode               | PN-0044          |              |
| D3,5,6          | LED                 | PNTLG124         | Green        |
| D4,15,17        | Diode, Bridge       | PND5FB20         |              |
| D8              | Diode               | PNU05C           |              |
| D12-14          | Diode               | PN-0264          |              |
| R1              | Resisotr            | R8CJ242M         | 2.4k         |
| R2              | Resistor            | R8BJ512M         | 5.1k         |
| R3,4            | Resistor            | R8BJ122M         | 1.2k         |
| R5,10           | Resistor            | R7CJR33M         | 0.33 ohm     |
| R14             | Resistor            | R7HF243M         | 24k          |
| R15             | Resistor            | R7HF332M         | 1/4W 3.3k    |
| R16             | Resistor            | R7HF153M         | 15k          |
| R20,35          | Resistor            | R8BJ202M         | 2k           |
| R21             | Resistor            | R7CJR39M         | 0.39 ohm     |
| R24,40          | Resistor            | R7HF393M         | 1/4W 39k     |
| R36,48          | Resistor            | R7DJR22M         | 0.22 ohm     |
| R46,47          | Resistor            | R8BJ152M         | 1.5k         |
| R65             | Resistor            | R7HF3402         | 34k          |
| C8,21,37        | F-Capacitor         | CFF3103          | 50V/0.01uF   |
| CN1,18          | Connector           | CN402350         | 2P           |
| CN2             | Connector, Header   | CN409085         |              |
| CN3             | Connector, S Header | CN404083         |              |
| CN4             | Connector, Header   | CN403082         |              |
| CN5             | Connector, Header   | CN402081         |              |
| CN6             | Connector, Plug     | CN409078         | 1uM          |
| CN7             | Connector           | CN405295         |              |
| CN8,16,17       | Connector           | CN406354         | 6P           |
| CN9,21          | Connector           | CN403351         | 3P           |
| CN10,13         | Connector           | CN410358         | 10P          |
| CN11            | Connector           | CN407355         | 7P           |
| CN12            | Connector           | CN409357         | 9P           |
| CN14            | Connector           | CN412380         | 12P          |
| CN15            | Connector           | CN408356         | 8P           |
| CN19            | Connector           | CN404352         | 4P           |
| CN20            | Connector           | CN405353         | 5P           |
| CN22,23         | Connector           | CN405296         |              |
| CN24,25         | Connector, Header   | CN406084         |              |
| CN26,27         | Connector           | CN402074         |              |

## Section 8

## [9]: PB-7JAB DISPLAY P.C.B. ASSEMBLY

| <u>Ref. No.</u> | <u>Description</u> | <u>Parts No.</u> | <u>Notes</u> |
|-----------------|--------------------|------------------|--------------|
|                 | P.C.B., LED        | PB9A932A         |              |
| D3-10           | LED                | PNTLR124         | Red          |
| D35-42          | LED                | PNTLY124         | Yellow       |
| D67-96          | LED                | PNTLG124         | Green        |
| D99-128         | LED                | PNTLO124         | Orange       |
| SW3-10          | Lever, Switch      | KN3002           | Vermilion    |
| SW3-10          | Switch             | WH42057          |              |
| SW35-42         | Lever, Switch      | KN3004           | Light Gray   |
| SW65            | Switch             | WH340463         |              |
| SW66            | Switch             | WH340433         |              |
| SW67            | Stopper, Switch    | PB7JA02          |              |
| CN3             | Connector          | CN403351         | 3P           |
| RE1             | Encoder            | SR3Z030          | 50 Pulse     |
|                 | Spacer             | KZ71A110         |              |
|                 | Angle              | PB7JA01          |              |
|                 | Plate, Shield      | PB7JA03          |              |



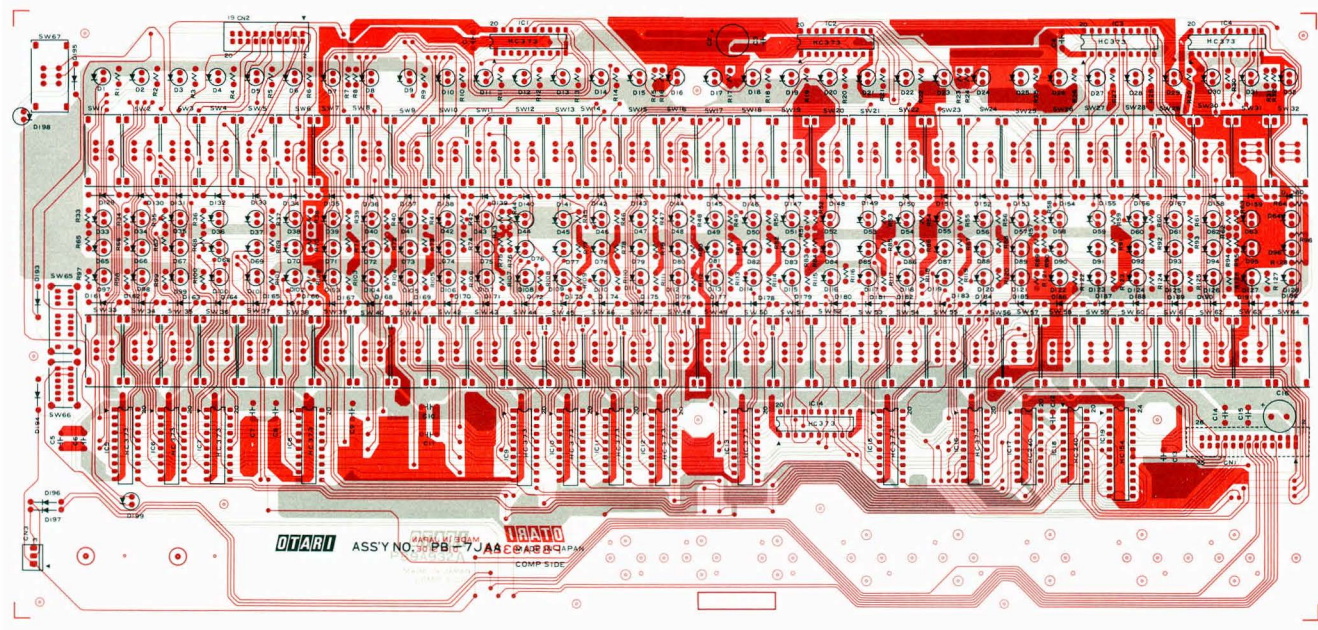

[10] : PB-4FGA CPU P.C.B. ASSEMBLY

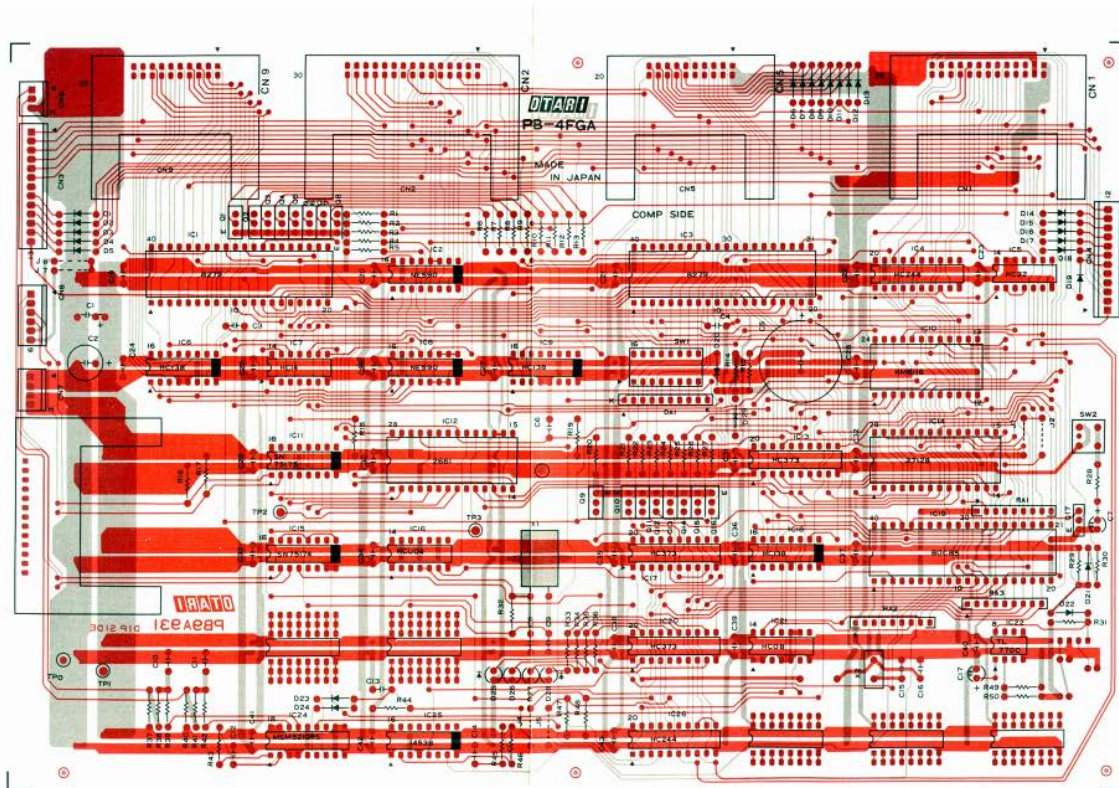

## [10]: PB-4FGA CPU P.C.B. ASSEMBLY

| <u>Ref. No.</u> | <u>Description</u> | <u>Parts No.</u> | <u>Notes</u> |
|-----------------|--------------------|------------------|--------------|
|                 | P.C.B., CPU        | PB9A931          |              |
|                 | ROM Assembly       | PG-0841          |              |
| IC10            | IC                 | IC-0075          |              |
| Q1-8            | Transistor         | Q-0004           |              |
| Q9-16           | Transistor         | Q-0011           |              |
| Q17             | Transistor         | Q-0008           |              |
| RA1             | Resistor           | R94-136          | 10k          |
| RA2,3           | Resistor Array     | R94-132          |              |
| C1,19-43        | Capacitor          | C622307M         | 50V/0.022uF  |
| C3,4,6          | F-Capacitor        | CFF3103          | 50V/0.01uF   |
| C5              | Capacitor          | C1105184         | 5V/1F        |
| C10,11          | Capacitor          | C656142M         | 50V/560pF    |
| C12,13          | Capacitor          | C622134M         | 50V/220pF    |
| SW1             | Switch, Dip        | WH98137          |              |
| SW2             | Switch             | WH11181          |              |
| TP0             | Connector          | CN901157         | Black        |
| TP1             | Connector          | CN901149         | Red          |
| CN1             | Connector          | CN326220         | 26P          |
| CN2             | Connector          | CN330221         |              |
| CN3             | Connector          | CN413381         | 13P          |
| CN4             | Connector          | CN412380         |              |
| CN5,9           | Connector          | CN320219         | 20P          |
| CN6             | Connector          | CN403351         | 3P           |
| CN7             | Connector          | CN404352         | 4P           |
| CN8             | Connector          | CN406354         |              |
| X1              | Crystal            | PZ4C033          |              |
| X2              | Crystal            | PZ4C017          |              |



SECTION 9:  
EXPLODED VIEW DRAWINGS AND PARTS LISTS

9.1 GENERAL

The following exploded view drawings and parts lists are provided for service reference. Each drawing has own parts list followed with a same key number and title.

When ordering parts, give a full description, using both the part number and the name of the part. If there seems to be a discrepancy between the drawings herein and your MX-80, contact OTARI; we assume no liability for improper servicing due to changes and improvements which we make that subsequently render certain of those documents obsolete. Most all of exploded view drawings are not prepared for the parts which differ from those for the MX-80, please refer to the parts list in which you will find the proper information. Following are the lists of the exploded view drawings edited here.

9.2 PARTS LISTS

| <u>Ref. No.</u> | <u>Description</u>              | <u>Parts No.</u> | <u>Notes</u> |
|-----------------|---------------------------------|------------------|--------------|
| 1               | Reel Assembly                   | KW-6E            |              |
| 2               | Capstan Assembly                | KC-6C            |              |
|                 | Pinch Roller Assembly           | KP-6A            |              |
| 3               | Tachometer Roller Assembly      | KI-6B            |              |
|                 | Impedance Roller Assembly       | KI-6C            |              |
|                 | Tension Arm Assembly            | KA-6D            |              |
| 4               | Shield Door Assembly            | ZA-73Z           |              |
|                 | Tape Shifter Assembly           | KR-6C            |              |
| 5               | Head Assembly (32ch)            | KH-6C            |              |
|                 | (24ch)                          | KH-6D            |              |
| 6               | Control Panel Assembly          | CB-20W           |              |
| 7               | VU Meter Assembly (32ch)        | CB-735           |              |
|                 | (24ch)                          | CB-736           |              |
| 8               | Amplifier Assembly (32ch)       | A1110            |              |
|                 | (24ch)                          | A1111            |              |
| 9               | Power Supply Assembly (32ch)    | DS-3J            |              |
|                 | (24ch)                          | DS-3K            |              |
| 10              | Rear Panel Assembly             | CB-738           |              |
|                 | Ext. Panel Assembly             | CB-749           |              |
| 11              | Audio I/O Panel Assembly (32ch) | CB-732           |              |
|                 | (24ch)                          | CB-733           |              |
| 12              | Remote Control Assembly (32ch)  | CB-123           |              |
|                 | (24ch)                          | CB-124           |              |



## Section 9

## [1]: REEL ASSEMBLY KW-6E

| <u>Ref. No.</u> | <u>Description</u>           | <u>Parts No.</u> | <u>Notes</u> |
|-----------------|------------------------------|------------------|--------------|
| 1- 1            | Reel Table Assembly          | KW0HGA           |              |
| 2               | Screw, Reel Location         | KW0E042          |              |
| 3               | Moter, DC Reel               | MR5A040          |              |
| 4               | Base, Brake Assembly         | KW1F001          |              |
| 5               | Brake Drum                   | KW0A056          |              |
| 6               | Brake Band                   | KW-6B-A          |              |
| 7               | Stand off                    | KZ9H140B         |              |
| 8               | Guide, Brake Band            | KW-6E-A          |              |
| 9               | Tach Disk                    | SR3Z024          |              |
| 10              | Bracket, Tach Sensor PCB     | KW6E001          |              |
| 11              | PCB Assembly, Tach Sensor    | PB-7BTA          |              |
| 12              | Solenoid, Brake              | GP1B02           |              |
| 13              | Stopper, Solenoid Plunger    | KZ2A015          |              |
| 14              | Link, Brake Adjustment       | KZ6A063          |              |
| 15              | Pin, Solenoid Plunger        | KZ5A003          |              |
| 16              | Bracket, Brake Band Mounting | KW6B004          |              |
| 17              | Lever, Brake                 | KW6B005          |              |
| 18              | Shaft, Brake Lever           | KW6B009          |              |
| 19              | Stopper, Brake Lever         | KW6B008          |              |
| 20              | Post, Spring Anchor          | KZ5B010          |              |
| 21              | Spring                       | GS1088           |              |
| 22              | Spring                       | GS1089           |              |
| 23              | Post, Adjustment             | KW6B007          |              |
| 24              | Link, Adjustment             | KW6B006          |              |
| 25              | Retaining Ring, E-Type       | F7502            |              |
| 26              | Retaining Ring, E-Type       | F74TE18          |              |
| 27              | Nut, Adjustment              | F517-4           |              |
| 28              | Connector, Plug Housing      | CN402030         |              |
| 29              | Connector, Plug Contact      | CN7B-041         |              |
| 30              | Connector, Plug Housing      | CN402260         |              |
| 31              | Connector, Pin Housing       | CN7B-206         |              |

[1]: REEL ASSEMBLY KW-6E

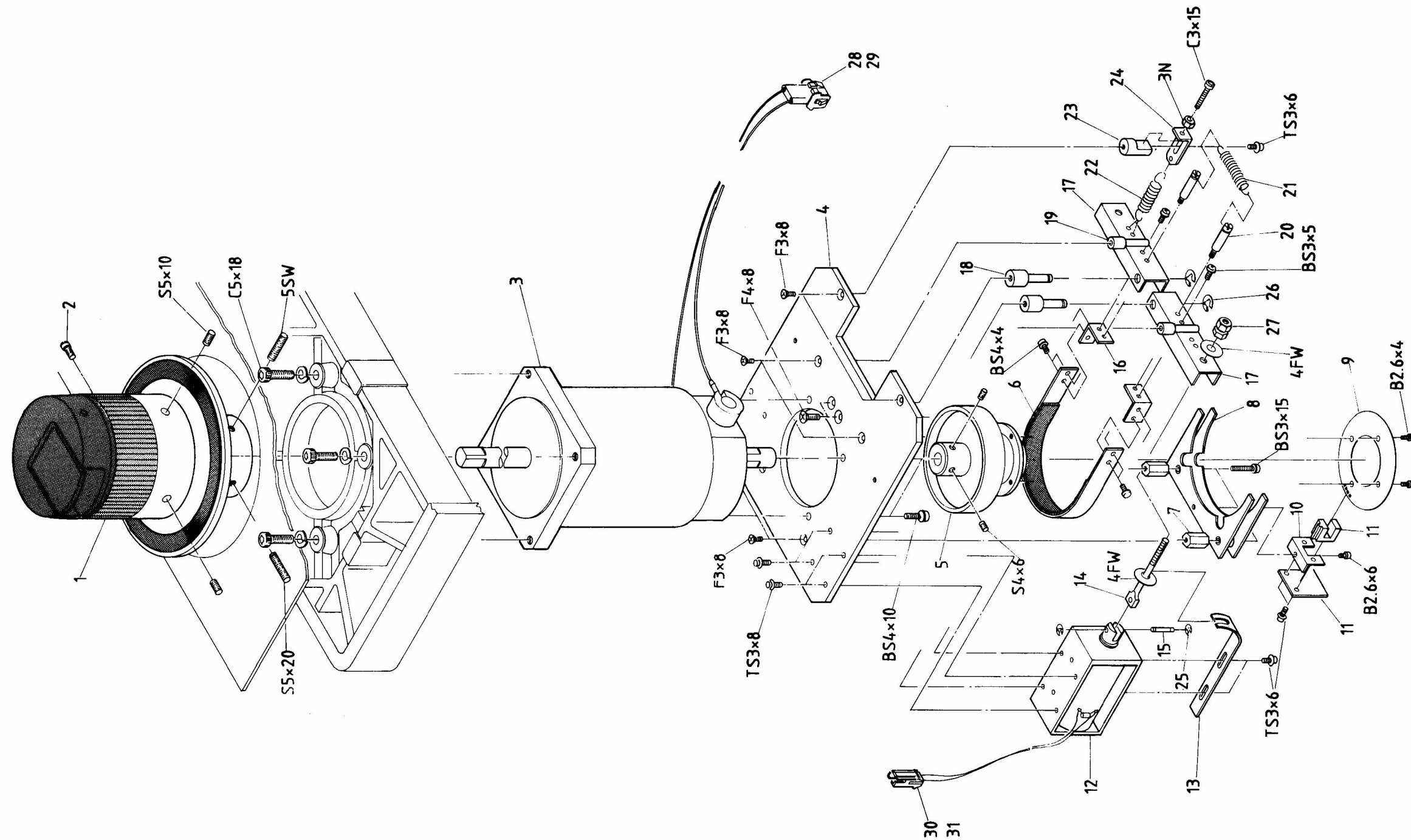

Section 9

[2]: CAPSTAN ASSEMBLY RC-6C  
PINCH ROLLER ASSEMBLY KP-6A

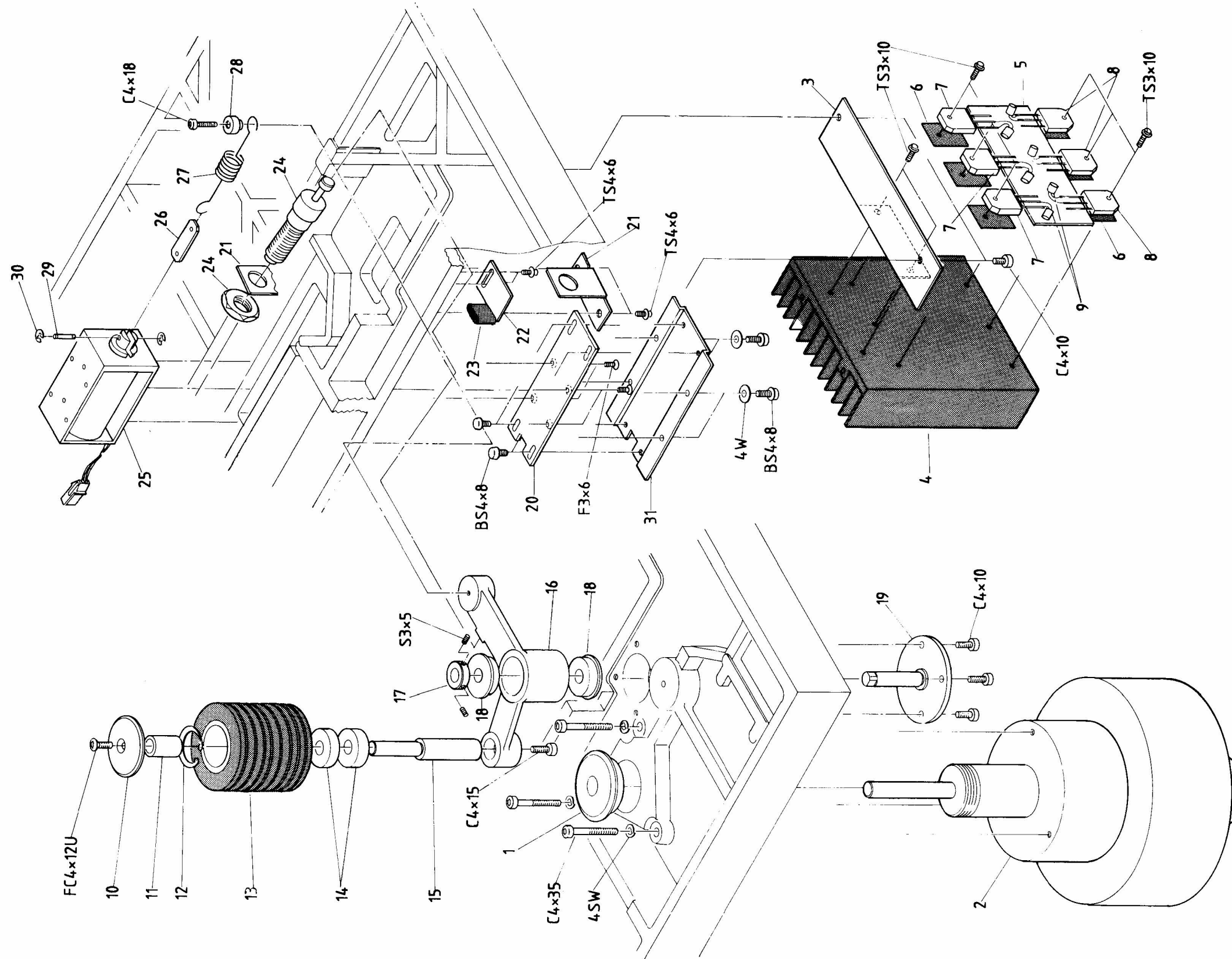



[2]: CAPSTAN ASSEMBLY KC-6C  
PINCH ROLLER ASSEMBLY KP-6A

| <u>Ref. No.</u> | <u>Description</u>           | <u>Parts No.</u> | <u>Notes</u> |
|-----------------|------------------------------|------------------|--------------|
| 2-              | 1 Cap, Capstan Dust          | KC6C001          |              |
|                 | 2 Motor, DC Capstan          | MR-1B            |              |
|                 | 3 Bracket, Heat Sink         | ZA93G01          |              |
|                 | 4 Heat Sink                  | KZ1A071          |              |
|                 | 5 PCB, Transistor            | PB9A906          |              |
|                 | 6 Insulator, Transistor      | PZ4B068          |              |
|                 | 7 Transistor                 | QD1436K          |              |
|                 | 8 Transistor                 | QB1032K          |              |
|                 | 9 Capacitor                  | CFF3102          |              |
|                 | 10 Cap, Pinch Roller         | KP0C023          |              |
|                 | 11 Spacer                    | KP6A008          |              |
|                 | 12 Retaining Ring, C-Type    | F712207          |              |
|                 | 13 Roller Assembly, Pinch    | KP0A037          |              |
|                 | 14 Bearing                   | BA1Z028          |              |
|                 | 15 Shaft, Pinch Roller       | KP0B050          |              |
|                 | 16 Arm, Pinch Roller         | KP6A005          |              |
|                 | 17 Boss                      | KP6A006          |              |
|                 | 18 Bearing                   | BAZ-608A         |              |
|                 | 19 Shaft, Pinch Roller Arm   | KP6A004          |              |
|                 | 20 Base, Solenoid            | KP6A009          |              |
|                 | 21 Bracket, Damper           | KP6A001          |              |
|                 | 22 Stopper, Solenoid Plunger | KP6A002          |              |
|                 | 23 Tube, Rubber              | KR6B011          |              |
|                 | 24 Damper, Pinch Roller      | AS5096           |              |
|                 | 25 Solenoid                  | GP1B12           |              |
|                 | 26 Link, Solenoid            | KP1D007          |              |
|                 | 27 Spring                    | GS1141           |              |
|                 | 28 Post, Spring Anchor       | KP6A007          |              |
|                 | 29 Pin, Solenoid Plunger     | KZ5A003          |              |
|                 | 30 Retaining Ring, E-Type    | F7502            |              |
|                 | 31 Bracket, Solenoid         | KP6A010          |              |



## Section 9

[3]: TACHOMETER ROLLER ASSEMBLY KI-6B  
 IMPEDANCE ROLLER ASSEMBLY KI-6C  
 TENSION ARM ASSEMBLY KA-6D

| <u>Ref. No.</u> | <u>Description</u>       | <u>Parts No.</u> | <u>Notes</u> |
|-----------------|--------------------------|------------------|--------------|
| 3- 1            | Cap, Roller              | KP0C023          |              |
| 2               | Retaining Ring, C-Type   | F7208.0          |              |
| 3               | Bearing                  | BA1Z028          |              |
| 4               | Washer, Cup Type         | F953A00          |              |
| 5               | Retaining Ring, C-Type   | F7022.0          |              |
| 6               | Roller Assembly, Counter | KI0A059          |              |
| 7               | Tack Disk                | SR3Z024          |              |
| 8               | Shaft, Counter Roller    | KI0A060          |              |
| 9               | Bracket, Tach Sensor PCB | KI6B001          |              |
| 10              | PCB, Tach Sensor         | PB-7LAA          |              |
| 11              | PCB, Tach Sensor         | PB-7DSA          |              |
| 12              | Retaining Ring, C-Type   | F7212.0          |              |
| 13              | Bearing                  | BA1Z011W         |              |
| 14              | Washer, Cup Type         | F953A005         |              |
| 15              | Retaining Ring, C-Type   | F7028.0          |              |
| 16              | Roller, Impedance        | KI0A061          |              |
| 17              | Shaft, Impedance Roller  | KI0A062          |              |
| 18              | Roller Assembly, Tension | GR-6R            |              |
|                 | Roller, Tension          | GR6R002          |              |
|                 | Cap, Roller              | KP0C023          |              |
|                 | Shaft, Tension Roller    | GR6R001          |              |
|                 | Spring                   | GS2115           |              |
|                 | Bearing                  | BA1Z028          |              |
|                 | Washer                   | KZ60055          |              |
|                 | Collar                   | KZ7C087          |              |
|                 | Retaining Ring C-Type    | F7208.0          |              |
| 19              | Shield, Tension Arm      | KA6D006          |              |
| 20              | Arm, Tension Roller      | KA6D001          |              |
| 21              | Shaft, Tension Arm       | KA6D002          |              |
| 22              | Bearing                  | BA2F608A         |              |
| 23              | Housing, Tension Arm     | KA1E003          |              |
| 24              | Collar, Tension Vane     | KA1E004          |              |
| 25              | Vane, Tension            | SR3Z028A         |              |
| 26              | Post, Spring Anchor      | KA6D004          |              |
| 27              | Spring                   | GS1142           |              |
| 28              | Screw, Tension Adjusting | KZ6A003          |              |
| 29              | Bracket, Spring          | KA6D005          |              |
| 30              | Post, Cushion            | KA6D003          |              |
| 31              | Cushion                  | CY5006           |              |
| 32              | Bracket, Damper          | KP6A001          |              |
| 33              | Damper, Tension Arm      | AS5096           |              |
| 34              | Holder, Tension Sensor   | SR1W001          |              |
| 35              | PCB, Tension Sensor      | PB-7AVA          |              |
| 36              | PCB, Safety Switch       | PB-4FHA          |              |

[3]: TACHOMETER ROLLER ASSEMBLY KI-6B  
IMPEDANCE ROLLER ASSEMBLY KI-6C  
TENSION ARM ASSEMBLY KA-6D

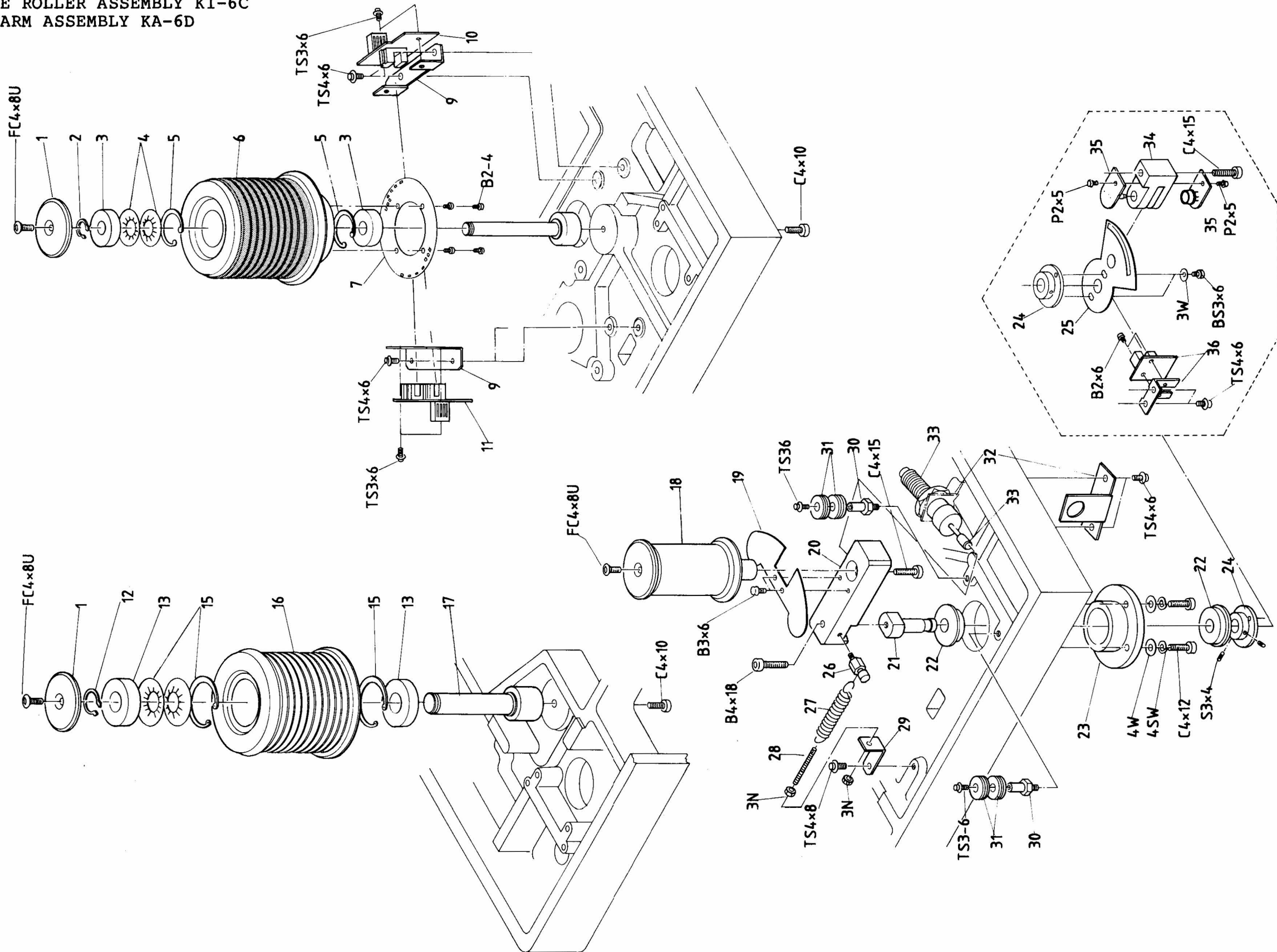





[4]: SHIELD DOOR ASSEMBLY ZA-73Z  
TAPE SHIFTER ASSEMBLY KR-6C

| <u>Ref. No.</u> | <u>Description</u>          | <u>Parts No.</u> | <u>Notes</u> |
|-----------------|-----------------------------|------------------|--------------|
| 4- 1            | Base, Shield Plate Assembly | ZA73Z18          |              |
| 2               | Shaft                       | ZA73Z02          |              |
| 3               | Bracket, Shield Plate       | ZA73Z19          |              |
| 4               | Spring                      | GS2116           |              |
| 5               | Damper, Shield Plate        | PZ1Z011          |              |
| 6               | Bracket, Damper             | ZA73Z17          |              |
| 7               | Hook                        | ZA73Z07          |              |
| 8               | Cover, Shield               | ZA73Z01          |              |
| 9               | Plate, Shield               | ZA73Z10          |              |
| 10              | Arm Assembly, Lock          | ZA-73ZA          |              |
| 11              | Washer                      | ZA73Z06          |              |
| 12              | Collar                      | ZA73Z05          |              |
| 13              | Spring                      | GS2117           |              |
| 14              | Nut, Adjustment             | F517-3           |              |
| 15              | Stopper, Solenoid Plunger   | ZA73Z03          |              |
| 16              | Solenoid                    | GP1M04           |              |
| 17              | Bracket, Solenoid           | ZA73Z08          |              |
| 18              | Link, Solenoid              | ZA73Z04          |              |
| 19              | Pin, Solenoid Plunger       | F62208           |              |
| 20              | Tapping Screw               | F322.606         |              |
| 21              | Shifter                     | KR6C002          |              |
| 22              | Arm, Shifter                | KR6C001          |              |
| 23              | Stopper, Bearing            | KR6C004          |              |
| 24              | Bearing                     | BA11260L         |              |
| 25              | Shaft, Shifter Arm          | KR6C003          |              |
| 26              | Screw                       | KR6C005          |              |
| 27              | Link, Solenoid              | KR6C008          |              |
| 28              | Solenoid, Shifter           | GP1B12           |              |
| 29              | Pin, Solenoid Plunger       | KZ5A003          |              |
| 30              | Bracket, Solenoid           | KP6A003          |              |
| 31              | Stopper, Solenoid Plunger   | KP6A002          |              |
| 32              | Tube, Rubber                | KR6B011          |              |
| 33              | Stopper                     | KR6C009          |              |
| 34              | Link, Shifter               | KR6C010          |              |
| 35              | Collar                      | KR6C006          |              |
| 36              | Nut, Adjustment             | KR1C003          |              |
| 37              | Link, Shifter               | KR6C011          |              |
| 38              | Spring                      | GS1144           |              |
| 39              | Bracket, Spring             | CN7D-003         |              |
| 40              | Retaining Ring, E-Type      | F75020           |              |
| 41              | Switch                      | WH51002          |              |
| 42              | Stopper                     | KR-6C-C          |              |
| 43              | Spark Killer                | CZ20001W         |              |



## Section 9

[5]: HEAD ASSEMBLY (32ch) KH-6C  
(24ch) KH-6D

| <u>Ref. No.</u> | <u>Description</u>           | <u>Parts No.</u> | <u>Notes</u> |
|-----------------|------------------------------|------------------|--------------|
| 5- 1            | Cover, Head                  | T003702          |              |
| 2               | Guide, Tape                  | KG6A001          |              |
| 3               | Head, 2" 32ch Erace          | GH6E013A         |              |
| 4               | Head, 2" 24ch Erace          | GH6E014A         |              |
| 5               | Head, 2" 32ch Record         | GH6R016A         |              |
| 6               | Head, 2" 24ch Record         | GH6R017A         |              |
| 7               | Head, 2" 32ch Reproduce      | GH6P015A         |              |
| 8               | Head, 2" 24ch Reproduce      | GH6R009A         |              |
| 9               | Roller Ass'y, Flutter Filter | GR-6J            |              |
| 10              | Base, Head Assembly          | KH0C066          |              |
| 11              | Shield, Head Base            | T003709          |              |
| 12              | Bracket, Head Connector      | KH6C001          |              |
| 13              | Clamp, Cable (32ch)          | KH6C002          |              |
| 14              | Clamp, Cable (24ch)          | KH6C003          |              |
| 15              | Clamp, Cable (32ch)          | KH6C004          |              |
| 16              | Clamp, Cable (24ch)          | KH6C005          |              |
| 17              | Connector, MR-Type           | CN234130         |              |
| 18              | Connector, MR-Type           | CN234129         |              |
| 19              | Pin, Head Base Location      | F63312           |              |

[5]: HEAD ASSEMBLY (32ch) KH-6C  
(24ch) KH-6D

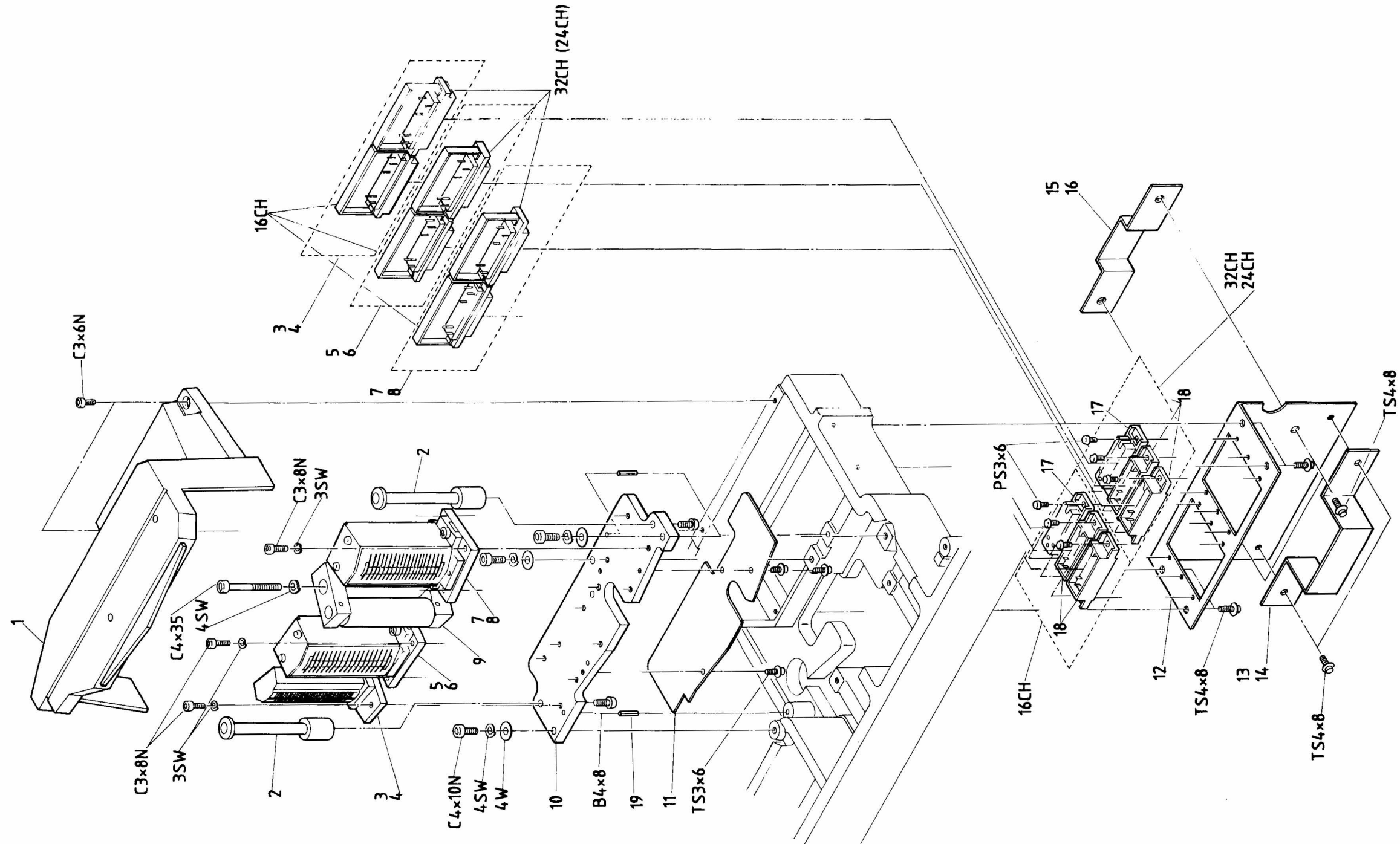

Section 9

[6]: CONTROL PANEL ASSEMBLY CB-20W

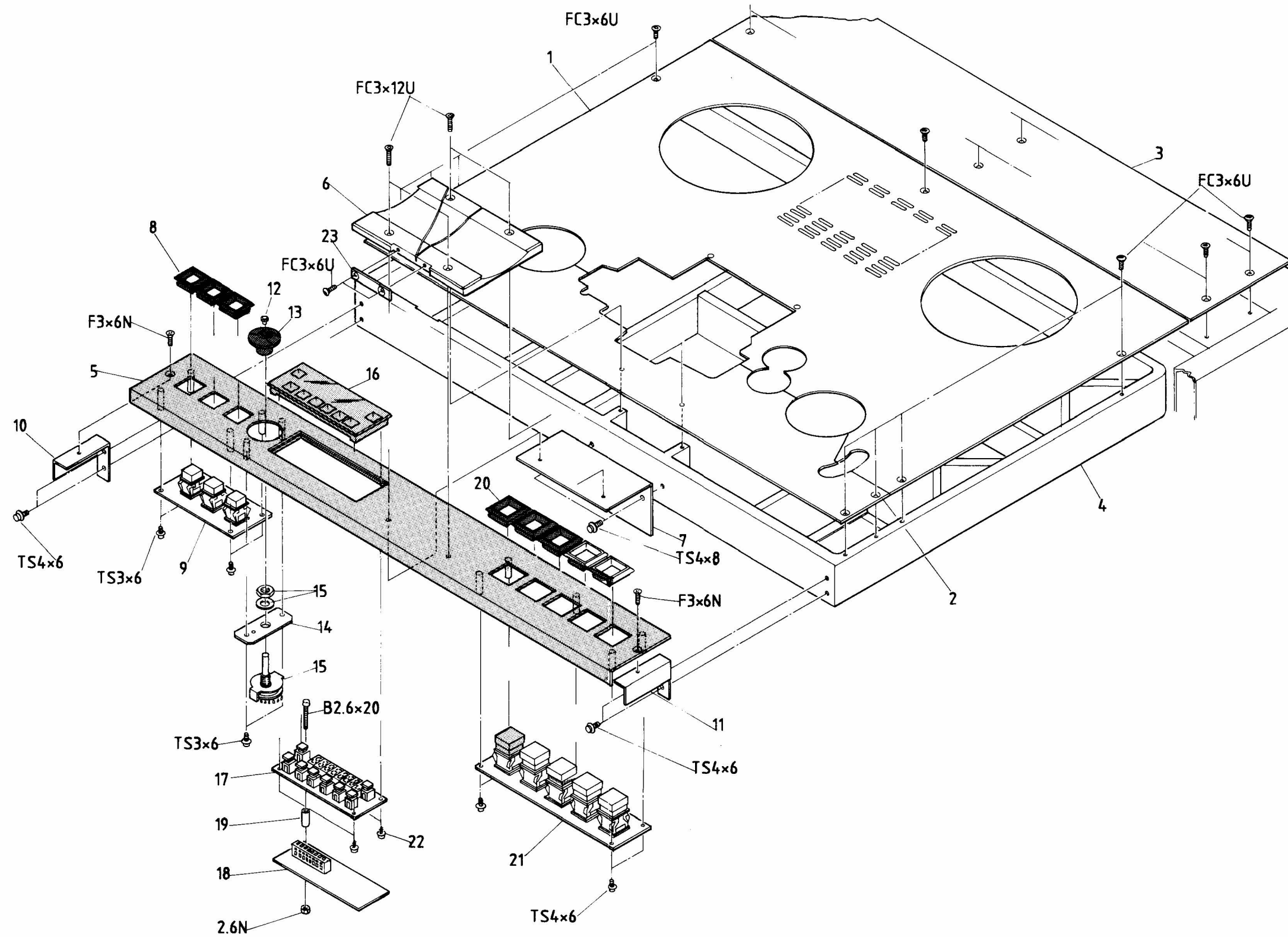

## [6]: CONTROL PANEL ASSEMBLY CB-20W

| <u>Ref. No.</u> | <u>Description</u>       | <u>Parts No.</u> | <u>Notes</u> |
|-----------------|--------------------------|------------------|--------------|
| 6- 1            | Deck Skin                | T003704          |              |
| 2               | Deck Skin, Front         | T003705          |              |
| 3               | Deck Skin, Rear          | T003706          |              |
| 4               | Deck Plate               | T003701          |              |
| 5               | Panel, Transport Control | CB20W01          |              |
| 6               | Splicing Block, 2"       | T003707          |              |
| 7               | Bracket, Splicing Block  | CB20W06          |              |
| 8               | Escutcheon, Switch       | PZ4A014          |              |
| 9               | PCB, Switch              | PB-7AKA          |              |
| 10              | Bracket, Control Panel   | CB20W02          |              |
| 11              | Bracket, Control Panel   | CB20W03          |              |
| 12              | Cap, Knob                | KN1058           |              |
| 13              | Knob                     | KN1059B          |              |
| 14              | Bracket, Switch          | CB20W04          |              |
| 15              | Switch, Rotary           | WH66067          |              |
| 16              | Lens, Tape Timer         | KN5011           |              |
| 17              | PCB, Switch/Timer        | PB-7HTA          |              |
| 18              | PCB, Timer Drive         | PB-7HUA          |              |
| 19              | Spacer                   | KZ71A109         |              |
| 20              | Escutcheon, Switch       | PZ4A013          |              |
| 21              | PCB, Switch              | PB-7AJB          |              |
| 22              | Tapping Screw            | F322.606         |              |
| 23              | Stopper, Blade           | T003708          |              |



Section 9

[7]: VU METER ASSEMBLY (32ch) CB-735  
 (24ch) CB-736

| <u>Ref. No.</u> | <u>Description</u>             | <u>Parts No.</u>  | <u>Notes</u> |
|-----------------|--------------------------------|-------------------|--------------|
| 7- 1            | Panel, VU Meter (32ch)         | CB73502           |              |
| 2               | Panel, VU Meter (24ch)         | CB73602           |              |
| 3               | VU Meter<br>Lamp, Meter        | ME11016<br>LU2065 |              |
| 4               | Cover, VU Meter Panel (32ch)   | CB73505           |              |
| 5               | Cover, VU Meter Panel (24ch)   | CB73605           |              |
| 6               | Holder, Panel Cover            | CB73507           |              |
| 7               | Holder, Panel Cover            | CB73609           |              |
| 8               | Bracket, VU Meter Panel        | K108906           |              |
| 9               | Collar, VU Meter Panel         | K108935           |              |
| 10              | Stud                           | KZ9F100A          |              |
| 11              | Tube, Rubber                   | KR6B001           |              |
| 12              | PCB Assembly, LED, Record      | PB-7ABA           |              |
| 13              | PCB Assembly, LED, Peak        | PB-7AAA           |              |
| 14              | PCB Assembly, VU Meter         | PB-7HXA           |              |
| 15              | Harness Assembly, VU Meter     | PZ9D137           |              |
| 16              | Harness Assembly, VU Meter     | PZ9D138           |              |
| 17              | Base, VU Meter Mounting (32ch) | CB73503           |              |
| 18              | Base, VU Meter Mounting (24ch) | CB73603           |              |

[7]: VU METER ASSEMBLY (32ch) CB-735  
(24ch) CB-736

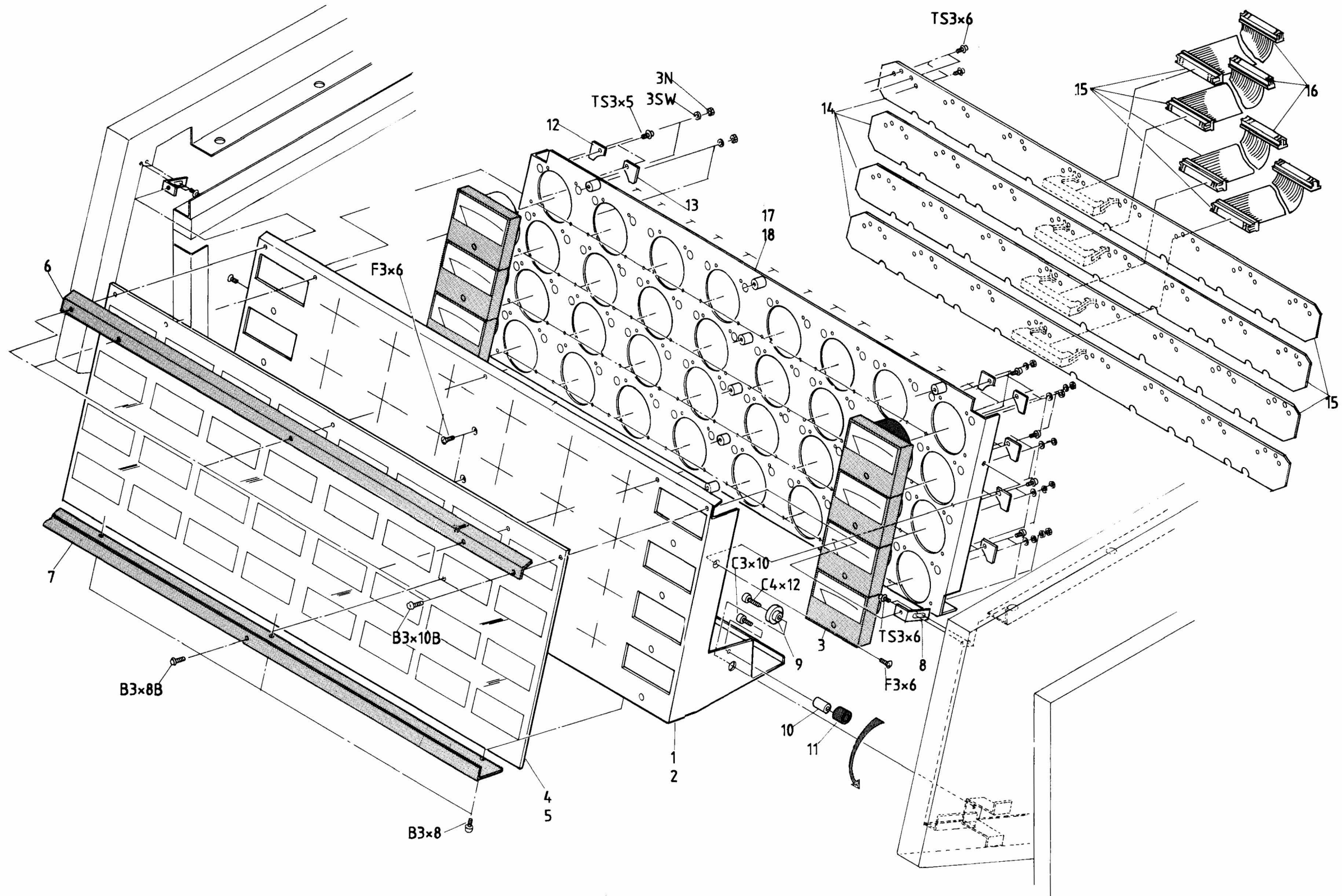



Section 9

[8]: AMPLIFIER ASSEMBLY (32ch) A1110  
(24ch) A1111

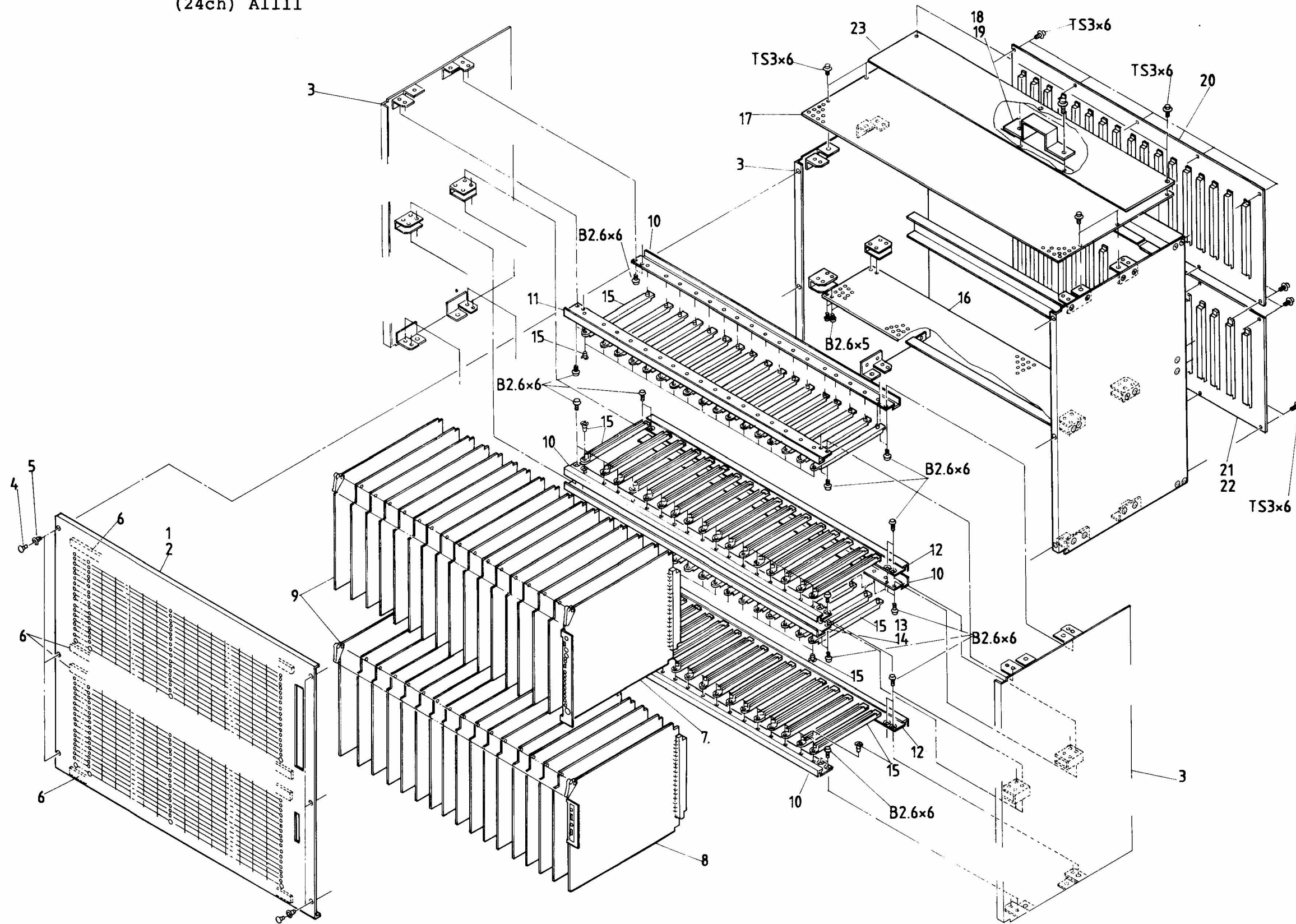

[8]: AMPLIFIER ASSEMBLY (32ch) A1110  
(24ch) A1111

| <u>Ref. No.</u> | <u>Description</u>                     | <u>Parts No.</u> | <u>Notes</u> |
|-----------------|--|------------------|--------------|
| 8- 1            | Panel, Amp Ass'y Front (32ch)          | A111006          |              |
| 2               | Panel, Amp Ass'y Front (24ch)          | A111102          |              |
| 3               | Cord Cage Assembly                     | A1110-A          |              |
| 4               | Fastener, Quick Release                | CY3036           |              |
| 5               | Collar, Fastener                       | CY3035           |              |
| 6               | Cushion                                | K109012          |              |
| 7               | PCB Assembly, Audio Control            | PB-4FFA          |              |
| 8               | PCB Assembly,<br>Serial Remote Control | PB-4EFA          |              |
| 9               | PCB Assembly, Audio Amplifier          | PB-19SA          |              |
| 10              | Angle, PCB Guide                       | A111004          |              |
| 11              | Angle, PCB Guide                       | A111001          |              |
| 12              | Angle, PCB Guide                       | A111003          |              |
| 13              | Angle, PCB Guide                       | A111002          |              |
| 14              | Angle, PCB Guide                       | A111101          |              |
| 15              | Guide, PCB                             | CN7B-014         |              |
| 16              | Plate                                  | A111008          |              |
| 17              | Cover, Card Cage Top                   | A111005          |              |
| 18              | Clamp, Cable                           | A111019          |              |
| 19              | Clamp, Cable                           | A111104          |              |
| 20              | PCB Assembly Mother A                  | PB-7HVA          |              |
| 21              | PCB Assembly Mother B1                 | PB-7HWA          |              |
| 22              | PCB Assembly Mother B2                 | PB-7HWA          |              |
| 23              | Plate, Shield                          | A111020          |              |



## Section 9

[9]: POWER SUPPLY ASSEMBLY (32ch) DS-3J  
(24ch) DS-3K

| <u>Ref. No.</u> | <u>Description</u>           | <u>Parts No.</u> | <u>Notes</u> |
|-----------------|------------------------------|------------------|--------------|
| 9- 1            | Heat Sink                    | KZ1A070          |              |
| 2               | Diode, Bridge                | PN-0190          |              |
| 3               | Transistor                   | ISTR900          |              |
| 4               | PCB, Transistor              | PB9A622          |              |
| 5               | Transistor                   | QB8630           |              |
| 6               | Transistor                   | QD11480          |              |
| 7               | Transistor                   | IHC7805H         |              |
| 8               | PCB, Transistor (L)          | PB9A393          |              |
| 9               | PCB, Transistor (S)          | PB9A385          |              |
| 10              | Collar, Transistor           | PZ4B036          |              |
| 11              | Insulator, Transistor        | PZ4B068          |              |
| 12              | Insulator, Transistor        | PZ4B055          |              |
| 13              | Insulator, Transistor        | PZ4B054          |              |
| 14              | Diode, Bridge                | PN0005           |              |
| 15              | Transistor                   | QB8630           |              |
| 16              | Insulator, Transistor        | ISTR9005         |              |
| 17              | Insulator, Transistor        | CN603221         |              |
| 18              | Fuse Holder                  | FH1-034          |              |
| 19              | Fuse 15A (32ch)              | FH9-019          |              |
| 20              | Fuse 10A (24ch)              | FH9-011          |              |
| 21              | Terminal, Ground             | CN901040         |              |
| 22              | Panel, Power Supply, Rear    | DS3J003          |              |
| 23              | Stand off                    | KZ9L200A         |              |
| 24              | PCB Assembly, Power Supply   | PB-622A          |              |
| 25              | Hinge, Front Panel (L)       | CY2015           |              |
| 26              | Hinge, Front Panel (R)       | CY2016           |              |
| 27              | Noise Filter                 | SF5009           |              |
| 28              | Transformer, Power           | TF11107          |              |
| 29              | Transformer, Power (32ch)    | TF11108          |              |
| 30              | Transformer, Power (24ch)    | TF11109          |              |
| 31              | Capacitor                    | C1223180         |              |
| 32              | PCB Assembly, Voltage Select | PB-7HYA          |              |
| 33              | Stand Off                    | KZ9L100A         |              |
| 34              | Cap, Leg                     | CY5007           |              |
| 35              | Panel, Power Supply, Front   | DS3J001          |              |
| 36              | Spacer                       | DS3J005          |              |
| 37              | Escutcheon                   | KN5007           |              |
| 38              | Switch, Power                | WH92101          |              |
| 39              | Capacitor, Spark Arrestor    | CZ20001W         |              |
| 40              | PCB Assembly, LED, Power     | PB-7MZA          |              |
| 41              | Spacer                       | KZ7A183          |              |
| 42              | Spacer                       | KZ9A075B         |              |
| 43              | Circuit Braker 10A (32ch)    | WH91092          |              |
| 44              | Circuit Braker 8A (32ch)     | WH91091          |              |
| 45              | Circuit Braker 2.5A (32ch)   | WH91086          |              |
| 46              | Circuit Braker 6.3A (32ch)   | WH91090          |              |
| 47              | Circuit Braker 4A (32ch)     | WH91088          |              |

| <u>Ref. No.</u> | <u>Description</u>          | <u>Parts No.</u> | <u>Notes</u> |
|-----------------|-----------------------------|------------------|--------------|
| 9-48            | Circuit Braker 15A (32ch)   | WH91093          |              |
| 49              | Circuit Braker 5A (32ch)    | WH91089          |              |
| 50              | Circuit Braker 3.15A (24ch) | WH91087          |              |
| 51              | Circuit Braker 4A (24ch)    | WH91088          |              |
| 52              | Caster, with Brake          | CY4082           |              |
| 53              | Caster, without Brake       | CY4081           |              |
| 54              | Collar                      | K108904          |              |
| 55              | Connector, Cap Housing      | CN412040         |              |
| 56              | Connector, Cap housing      | CN409038         |              |
| 57              | Connector, Pin Contact      | CN7B-043         |              |
| 58              | Connector, Socket Contact   | CN7B-041         |              |

[9]: POWER SUPPLY ASSEMBLY (32ch) DS-3J  
(24ch) DS-3K

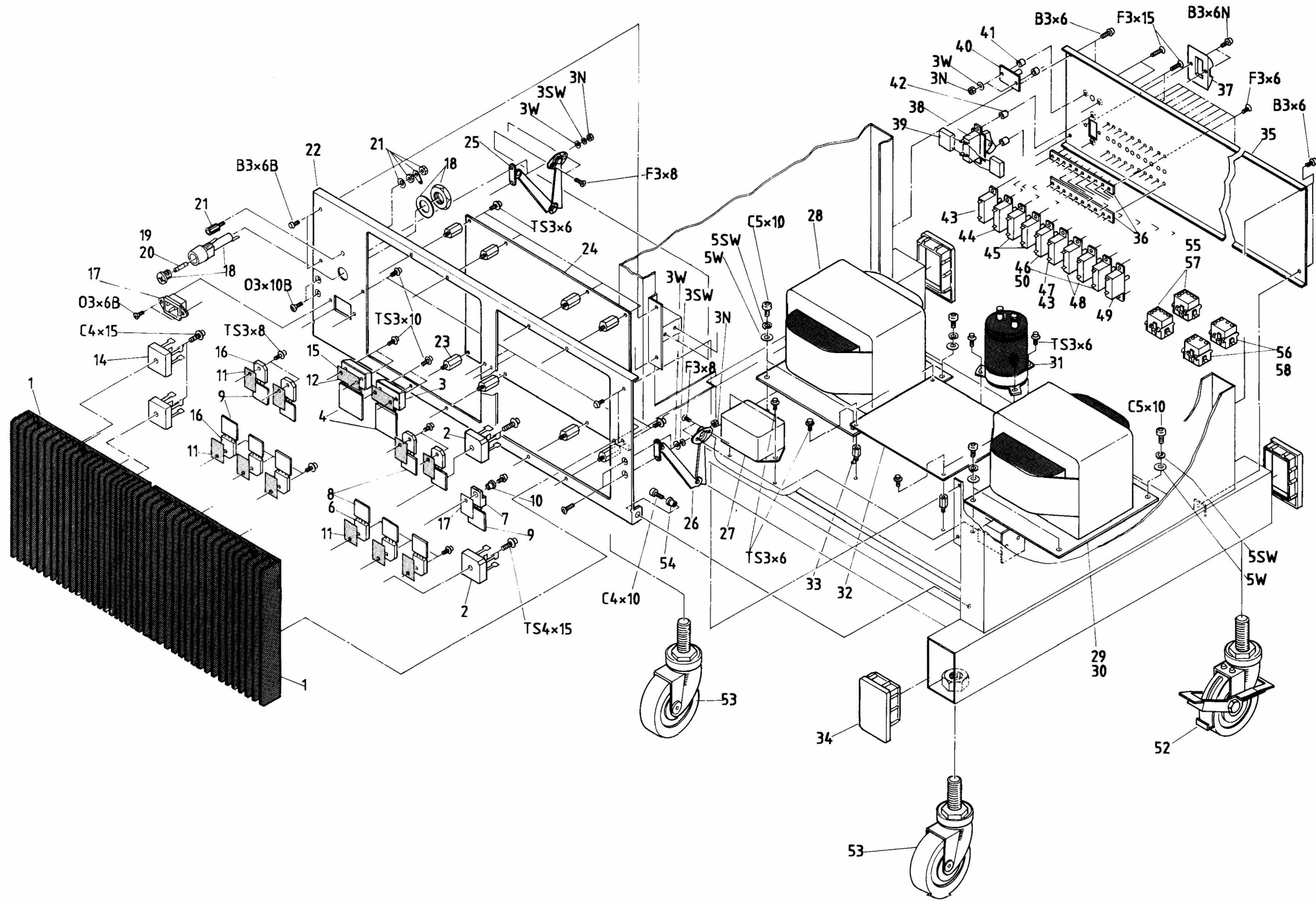



Section 9

[10]: REAR PANEL ASSEMBLY CB-738  
EXT. PANEL ASSEMBLY CB-749

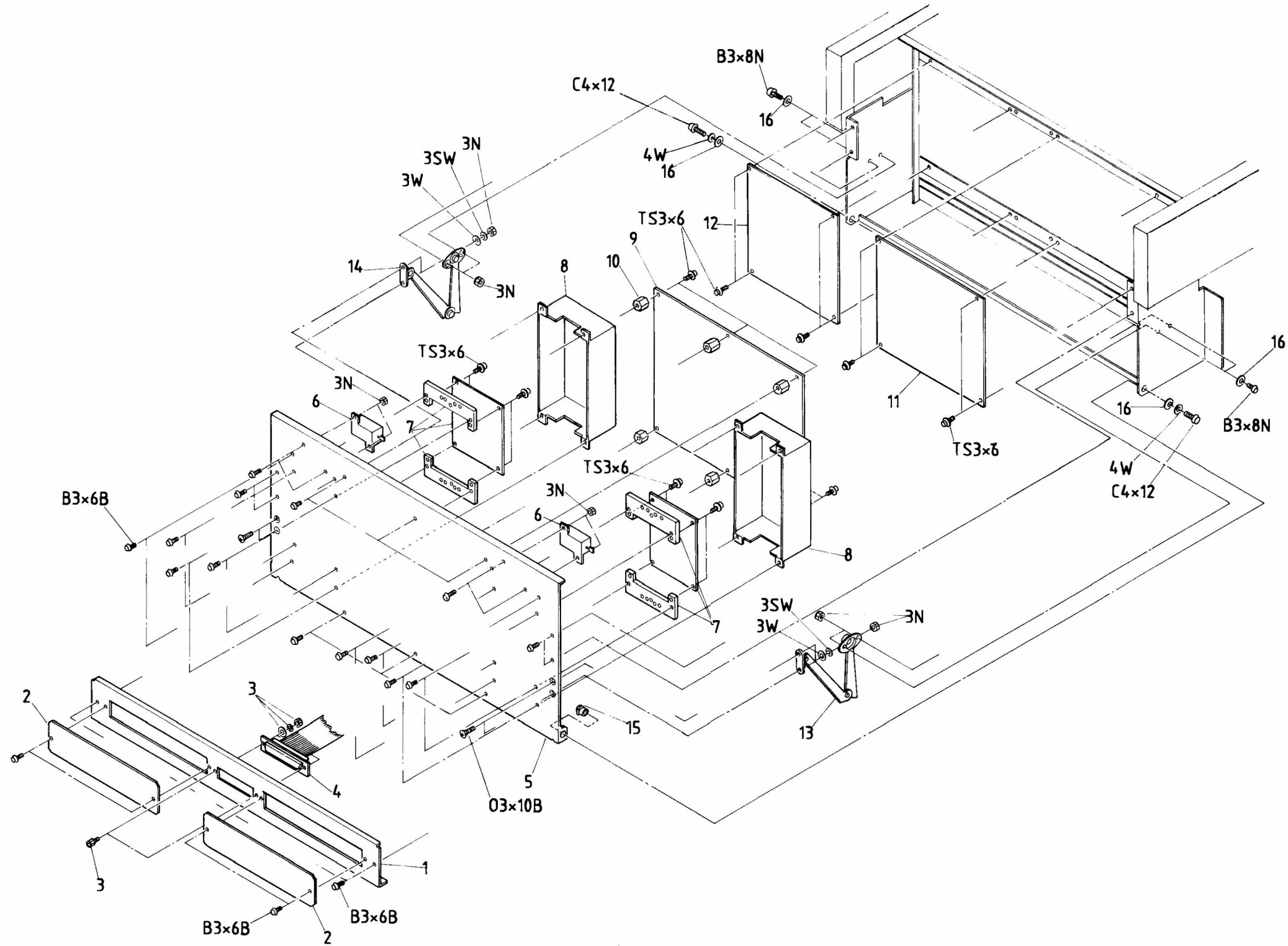

[10]: REAR PANEL ASSEMBLY CB-738  
EXT. PANEL ASSEMBLY CB-749

| <u>Ref. No.</u> | <u>Description</u>            | <u>Parts No.</u> | <u>Notes</u> |
|-----------------|-------------------------------|------------------|--------------|
| 10- 1           | Panel, I/O                    | CB74901          |              |
| 2               | Panel, Blank                  | CB74903          |              |
| 3               | Lock, Connector               | CN7B-212         |              |
| 4               | Connector Ass'y, Parallel I/O | PZ9D164          |              |
| 5               | Panel, Rear                   | CB73801          |              |
| 6               | Resistor 150 ohm              | R97-002          |              |
| 7               | PCB Assembly, Reel Drive      | PB-4FCA          |              |
| 8               | Shield Plate                  | CB73803          |              |
| 9               | PCB Ass'y, Transport Control  | PB-4FDA          |              |
| 10              | Stand off                     | KZ9H100A         |              |
| 11              | PCB Ass'y, Capstan Control    | PB-4FAA          |              |
| 12              | PCB Ass'y, Reel Control       | PB-4FBA          |              |
| 13              | Hinge, Front Door (R)         | CY2015           |              |
| 14              | Hinge, Front Door (L)         | CY2016           |              |
| 15              | Collar                        | K108904          |              |
| 16              | Washer, Nylon                 | KZ6C043          |              |



Section 9

[11]: AUDIO I/O PANEL ASSEMBLY (32ch) CB-732  
 (24ch) CB-733

| <u>Ref. No.</u> | <u>Description</u>            | <u>Parts No.</u> | <u>Notes</u> |
|-----------------|-------------------------------|------------------|--------------|
| 11- 1           | Panel, Audio I/O (32ch)       | CB73201          |              |
| 2               | Panel, Audio I/O (24ch)       | CB73301          |              |
| 3               | Connector, XL-Type Receptacle | CN103046         |              |
| 4               | Connector, XL-Type Plug       | CN103045         |              |
| 5               | Panel, Blank                  | CB74903          |              |
| 6               | Cable Assembly, NR            | ZA-6EF           |              |
| 7               | Cable Assembly, NR            | ZA-6EG           |              |
| 8               | Lock, Connector               | CN7B-061         |              |
| 9               | Hinge, Front Panel (R)        | CY2016           |              |
| 10              | Hinge, Front Panel (L)        | CY2015           |              |
| 11              | Collar                        | K108904          |              |

[11]: AUDIO I/O PANEL ASSEMBLY (32ch) CB-732  
(24ch) CB-733

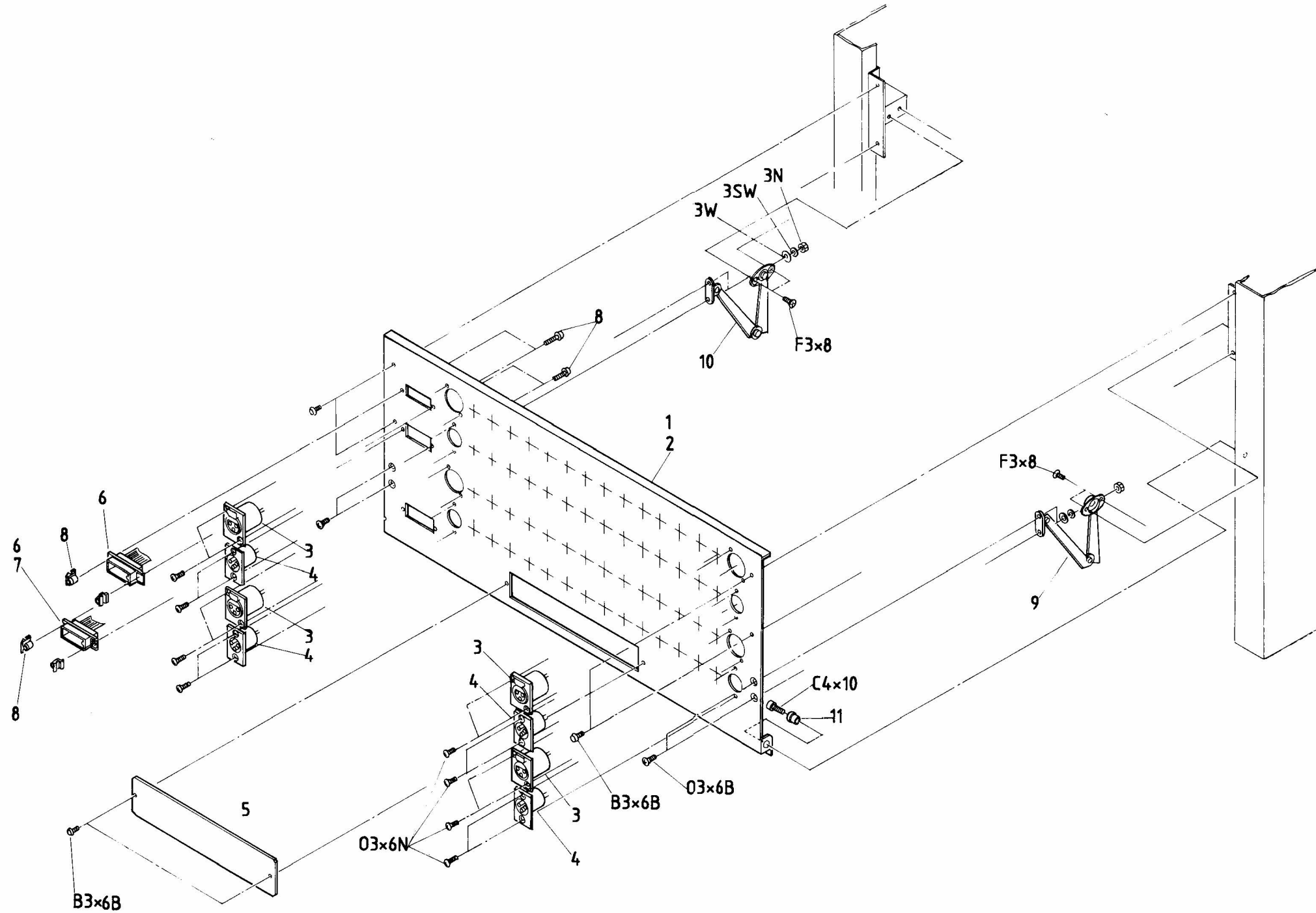

Section 9

[12]: REMOTE CONTROL ASSEMBLY (32ch) CB-123  
(24ch) CB-124

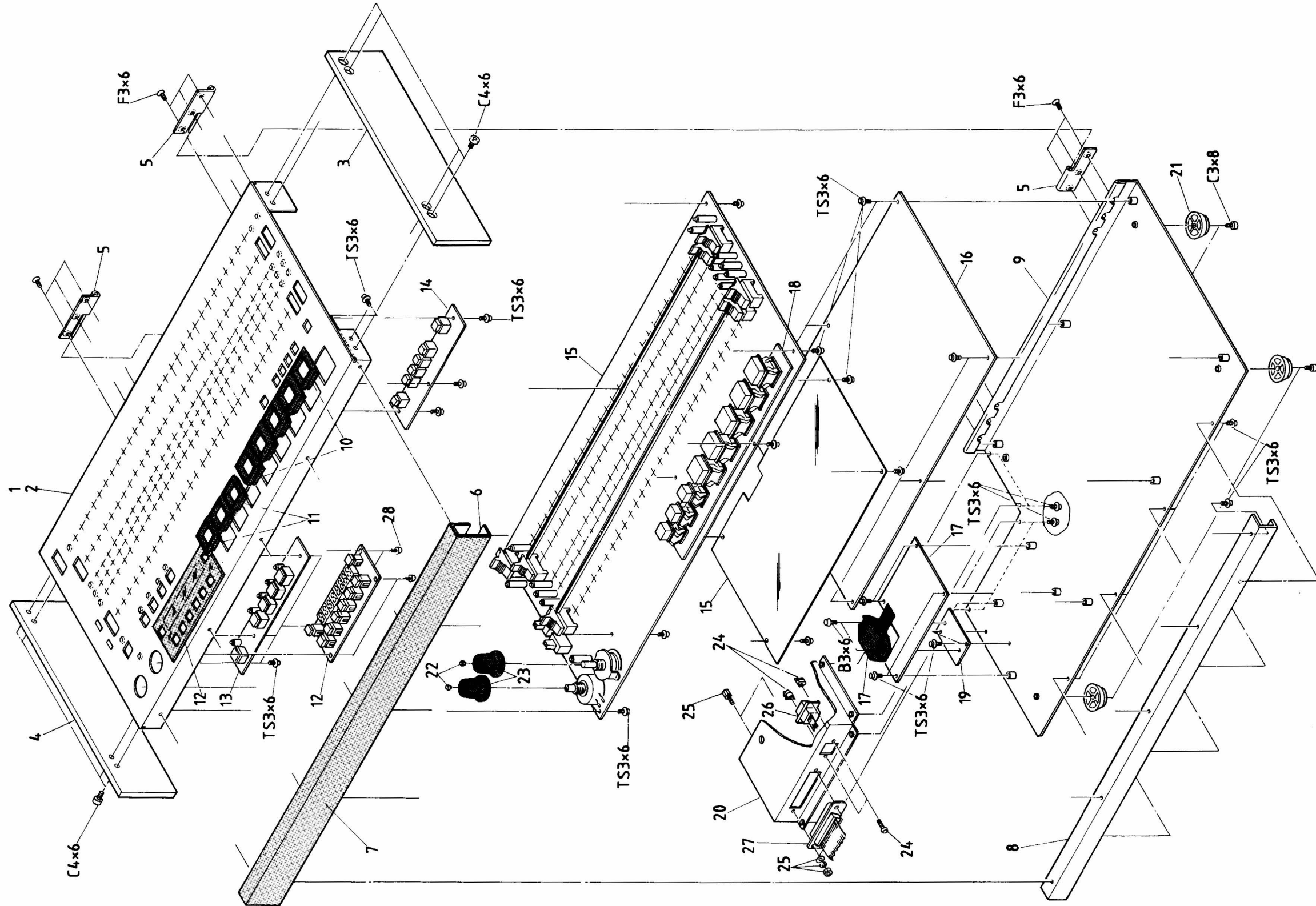

[12]: REMOTE CONTROL ASSEMBLY (32ch) CB-123  
(24ch) CB-124

| <u>Ref. No.</u> | <u>Description</u>             | <u>Parts No.</u> | <u>Notes</u> |
|-----------------|--------------------------------|------------------|--------------|
| 12- 1           | Panel, Top (32ch)              | CB-123A          |              |
| 2               | Panel, Top (24ch)              | CB-124A          |              |
| 3               | Plate, Side (R)                | CB12302          |              |
| 4               | Plate, Side (L)                | CB12303          |              |
| 5               | Hinge                          | CY2023           |              |
| 6               | Protector                      | CB12304          |              |
| 7               | Sheet, Leather                 | CB12310          |              |
| 8               | Protector                      | CB12309          |              |
| 9               | Panel, Bottom                  | CB12311          |              |
| 10              | Escutcheon                     | PZ4A013          |              |
| 11              | Escutcheon                     | PZ4A014          |              |
| 12              | PCB Ass'y, Timer/Switch        | PB-7JGA          |              |
| 13              | PCB Ass'y, Master Switch       | PB-7JCA          |              |
| 14              | PCB Ass'y, Channel Set Up      | PB-7JDA          |              |
| 15              | PCB Ass'y, Display (32ch)      | PB-7JAA          |              |
|                 | PCB Ass'y, Display (24ch)      | PB-7JAB          |              |
| 16              | PCB Ass'y, CPU                 | PB-4FGA          |              |
| 17              | PCB Ass'y, Power Supply        | PB-63AA          |              |
| 18              | PCB Ass'y, Transport Switch    | PB-7JCA          |              |
| 19              | Heat Sink                      | CB12305          |              |
| 20              | Panel, Connector               | CB12314          |              |
| 21              | Foot, Case                     | CY4063           |              |
| 22              | Cap, Knob                      | KN1048           |              |
| 23              | Knob                           | KN1046           |              |
| 24              | Lock, Connector                | CN7B-061         |              |
| 25              | Lock, connector                | CN7B-212         |              |
| 26              | Cable Assembly, Aux. Power     | ZA-6EM           |              |
| 27              | Cable Assembly, Remote Control | ZA-6EL           |              |
| 28              | Tapping Screw                  | F32C06SZ         |              |



**MX-80 SERIES TAPE RECORDER**

SCHMATIC DIAGRAMS (1/2)

TYPE C~

| PART No. | DESCRIPTION                              | DWG No. |
|----------|--|---------|
| T00370B  | Wiring Diagram (32ch)                    | 3-12538 |
| T00370C  | Wiring Diagram (24ch)                    | 3-12539 |
| T00370D  | Wiring Diagram (16ch)                    | 3-12540 |
| KH6C00B  | Head Wiring Diagram (32ch)               | 3-12541 |
| KH6D00B  | Head Wiring Diagram (24ch)               | 3-12542 |
| KH6E00B  | Head Wiring Diagram (16ch)               | 3-12543 |
| T00370E  | Transport Wiring Diagram                 | 3-12544 |
| CB20W0B  | Control Panel Assembly                   | 3-12635 |
| CB20W0C  | Control Panel Assembly                   | 3-12637 |
| PB7AJ0A  | Switch PCB Assembly ( I )                | 3-12641 |
| PB7AK0A  | Switch PCB Assembly ( II )               | 4-37429 |
| ZA93E0A  | Timer Display Assembly                   | 3-12645 |
| PB7HT0A  | Timer Indicator PCB Assembly             | 3-12639 |
| PB7HU0A  | Timer Drive PCB Assembly                 | 3-12643 |
| SR1W00A  | Tension Detect Assembly                  | 4-37460 |
| PB7LA0A  | Tach ( I ) PCB Assembly                  | 4-42942 |
| PB7DS0A  | Tach ( II ) PCB Assembly                 | 4-42330 |
| PB4FH0A  | Safety PCB Assembly                      | 4-42934 |
| PB7MV0A  | Reel Tach PCB Assembly                   | 4-43028 |
| PB4FD0B  | Transport Control Brock Diagram          | 3-12633 |
| PB4FD0A  | Transport Control PCB Assembly (1/2)     | 3-12691 |
|          | Transport Control PCB Assembly (2/2)     | 3-12692 |
| PB4HJ0A  | Pinch ADJ PCB Assembly                   | 3-12654 |
| PB4FC0A  | Reel Drive PCB Assembly                  | 3-12617 |
| PB4FB0A  | Reel Control PCB Assembly                | 3-12608 |
| ZA93G0A  | Capstan Drive Assembly                   | 4-42937 |
| PB4FA0A  | Capstan Control PCB Assembly             | 3-12607 |
| PB4FE0A  | Serial Remote Control PCB Assembly (1/2) | 3-12651 |
|          | Serial Remote Control PCB Assembly (2/2) | 3-12652 |
| PB4EZ0A  | 422 DRV/RCV PCB Assembly                 | 4-42796 |
| PB7HX0A  | VU Meter PCB Assembly                    | 3-12519 |
| PB7AA0A  | Record Indicator PCB Assembly            | 4-36987 |
| PB7AB0A  | Peak Indicator PCB Assembly              | 4-36989 |

CONTINUED ON NEXT PAGE

**MX-80 SERIES TAPE RECORDER**

**SCHEMATIC DIAGRAMS (2/2)**

TYPE C~

| PART No. | DESCRIPTION                             | DWG No. |
|----------|---|---------|
| A11100B  | Audio Wiring Diagram (32ch)             | 3-12545 |
| A11110B  | Audio Wiring Diagram (24ch)             | 3-12546 |
| A11220B  | Audio Wiring Diagram (16ch)             | 3-12547 |
| PB4FF0A  | Audio Control PCB Assembly (Command)    | 3-12548 |
|          | Audio Control PCB Assembly (Clock)      | 3-12549 |
| PB19J0A  | Audio Amplifier PCB Assembly (Playback) | 3-12735 |
|          | Audio Amplifier PCB Assembly (Record)   | 3-12736 |
|          | Audio Amplifier PCB Assembly (Bias)     | 3-12739 |
|          | Audio Amplifier PCB Assembly (Control)  | 3-12738 |
| PB7HVOA  | Mother A PCB Assembly                   | 3-12554 |
| PB7HW0A  | Mother B PCB Assembly                   | 3-12555 |
| PB7KG0A  | Mother C PCB Assembly                   | 3-12556 |
| DS3J00B  | Power Supply Assembly Wiring            | 3-12557 |
| DS3J00A  | Power Supply Assembly                   | 3-12610 |
| DS3J00C  | Circuit Protector Assembly              | 4-42936 |
| PB7HY0A  | Voltage Select PCB Assembly             | 3-12609 |
| PB7HZ0A  | Power Indicator PCB Assembly            | 4-42935 |
| CB1230B  | Remote Controller Wiring Diagram        | 3-12630 |
| PB4FG0A  | CPU PCB Assembly                        | 3-12619 |
| PB63A0A  | Power PCB Assembly                      | 3-12622 |
| PB7JA0A  | Display PCB Assembly                    | 3-12620 |
| PB7JB0A  | Transport Switch PCB Assembly           | 3-12625 |
| PB7JCOA  | Master Switch PCB Assembly              | 4-42946 |
| PB7JDOA  | Channel Set Up PCB Assembly             | 4-42943 |
| PB7JGOA  | Timer Indicator PCB Assembly            | 3-12624 |

| Model         | Note  |
|---------------|---|
| MX-80-32-H    | 2" 32ch, High Speed Version                   |
| MX-80-32-L    | 2" 32ch, Low Speed Version                    |
| MX-80-24/32-H | 2" 24ch Prewired for 32ch, High Speed Version |
| MX-80-24/32-L | 2" 24ch Prewired for 32ch, Low Speed Version  |
| MX-80-24-H    | 2" 24ch, High Speed Version                   |
| MX-80-24-L    | 2" 24ch, Low Speed Version                    |
| MX-80-16-H    | 2" 16ch, High Speed Version                   |
| MX-80-16-L    | 2" 16ch, Low Speed Version                    |

High Speed :  
30ips/15ips

Low Speed :  
15ips/7.5ips

REVISED 2 MAR. 1987



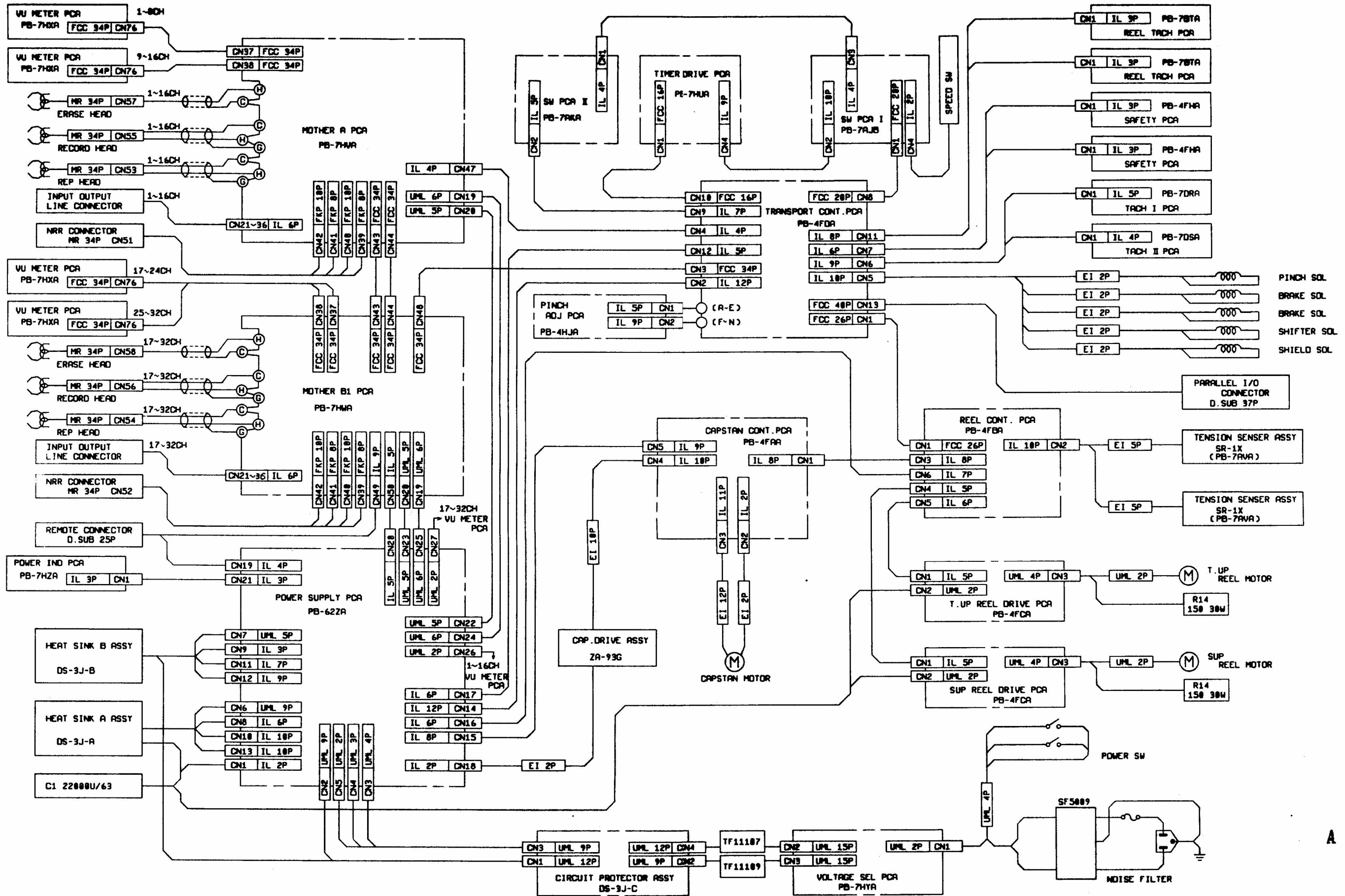

|          |                       |          |
|----------|-----------------------|----------|
| NAME     | WIRING DIAGRAM (32CH) | SHEET OF |
| PART NO. | T00370B               | 2538     |
| APPLIED  | MX-80-32              |          |

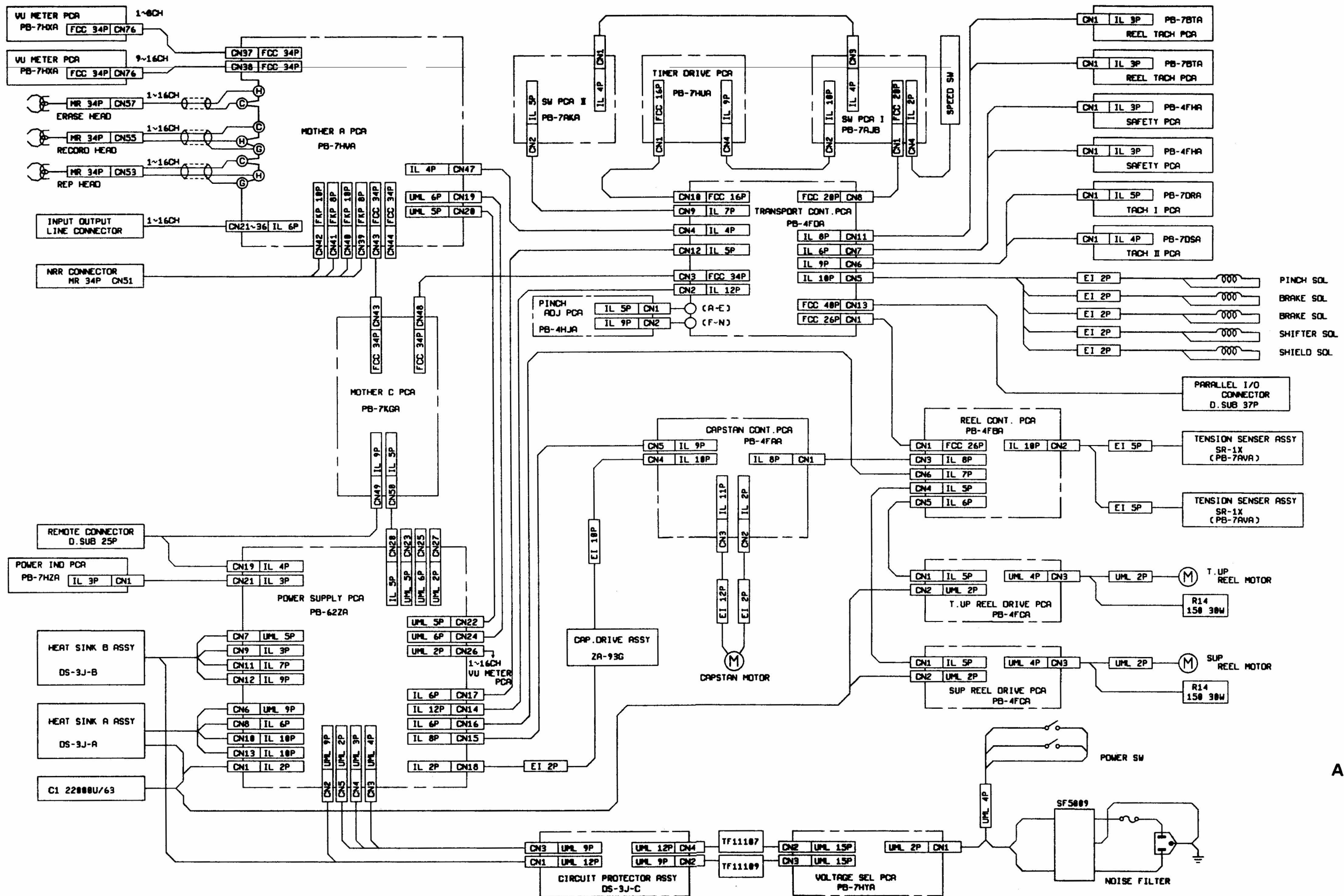

A

|          |                       |          |
|----------|-----------------------|----------|
| NAME     | WIRING DIAGRAM (16CH) | SHEET OF |
| PART NO. | T00370D               | 12540    |
| APPLIED  | MX-80-16              |          |



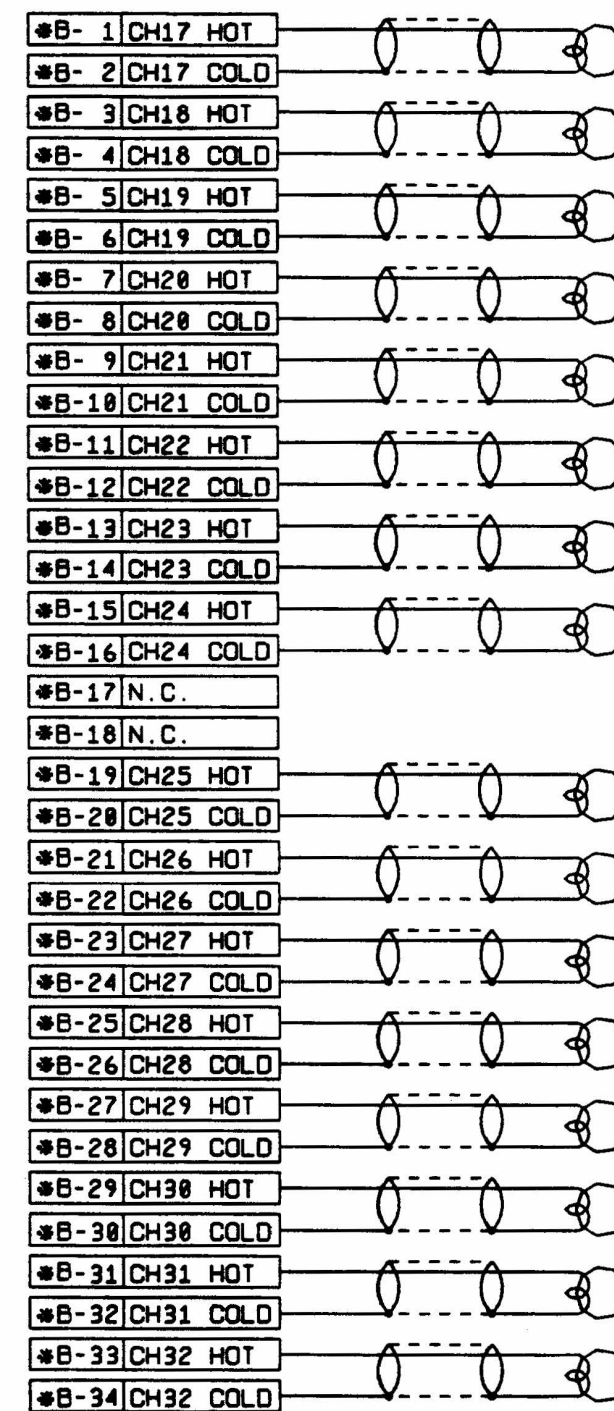
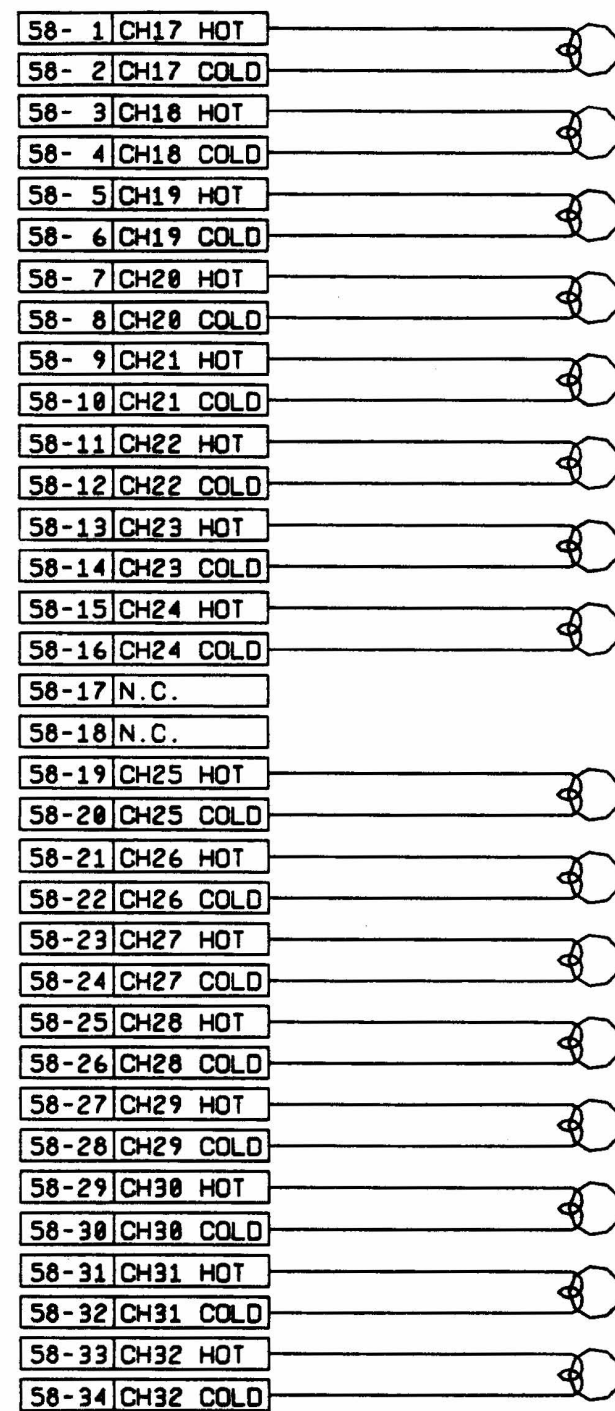
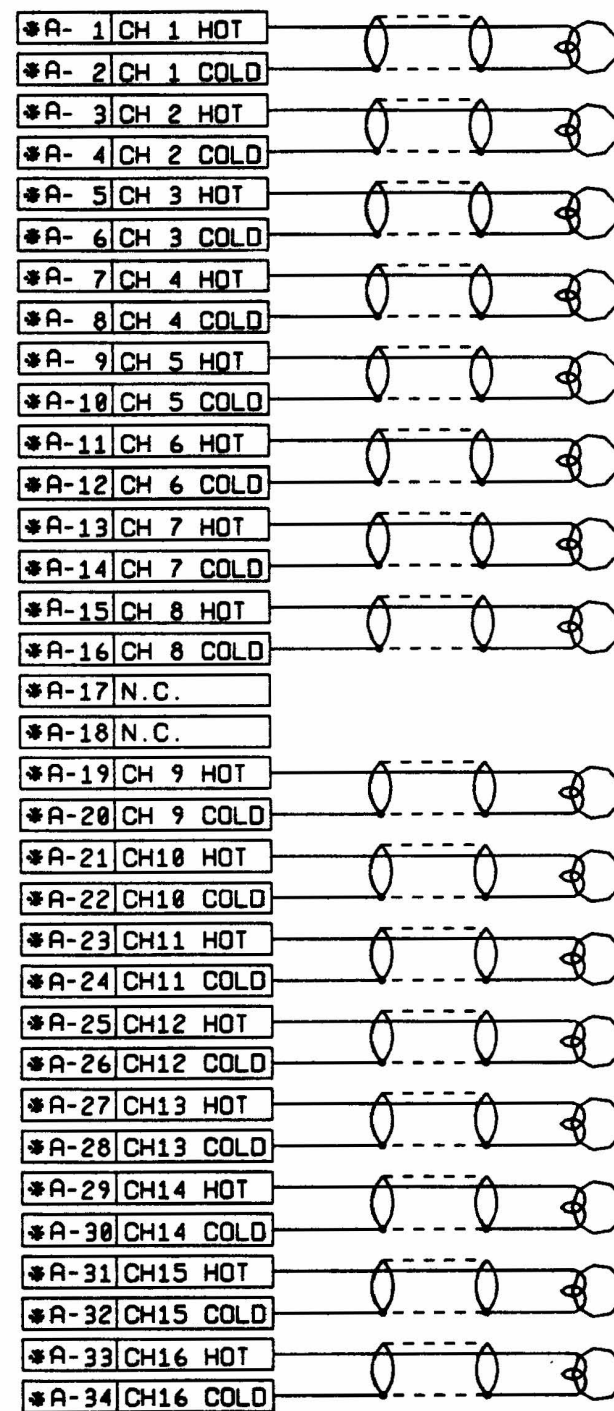
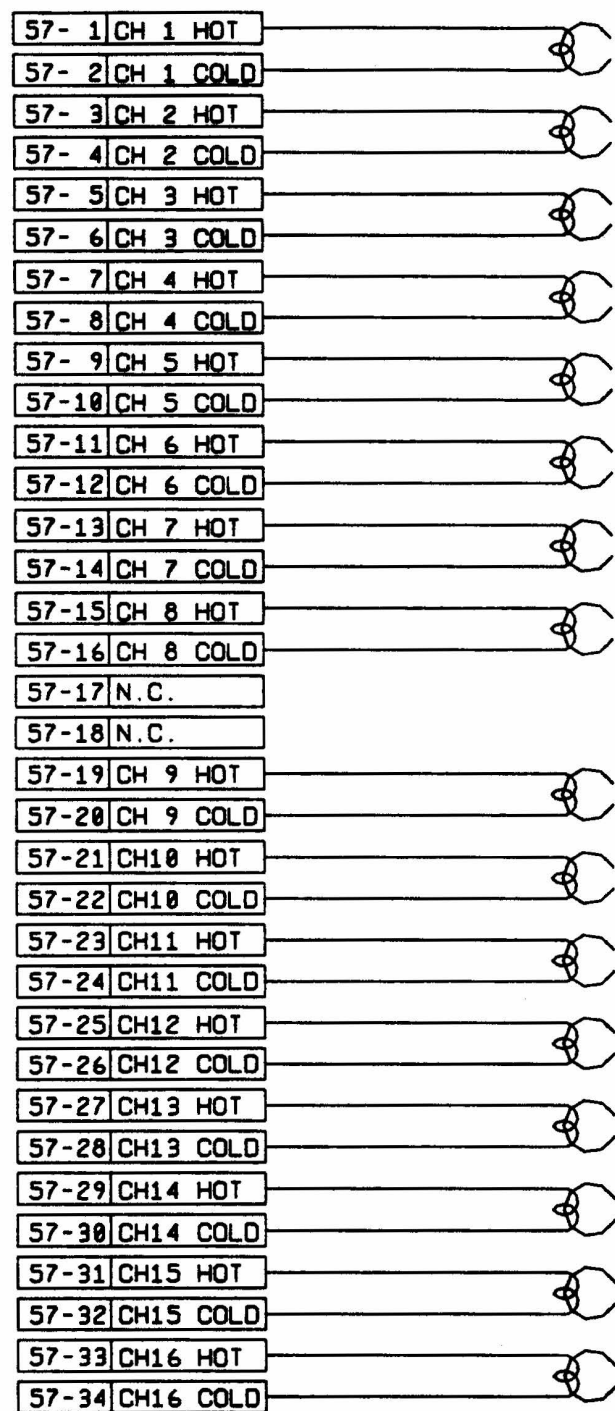

| *A   | *B   | HEAD   |
|------|------|--------|
| CN53 | CN54 | REPRO  |
| CN55 | CN56 | RECORD |

| CN    | TO HEAD | OTARI PART NO. | DESCRIPTION |
|-------|---------|----------------|-------------|
| 53,54 | REPRO   | CN234130       | MR-34F      |
| 55,56 | RECORD  | CN234130       | MR-34F      |
| 57,58 | ERASE   | CN234129       | MR-34M      |

A

|          |  |
|----------|--|
| NAME     | HEAD WIRING DIAGRAM SHEET<br>(32CH) 1 OF 1 |
| PART NO. | KH6C00B                                    |
| APPLIED  | KH-6C                                      |

Dwg. No. 12541



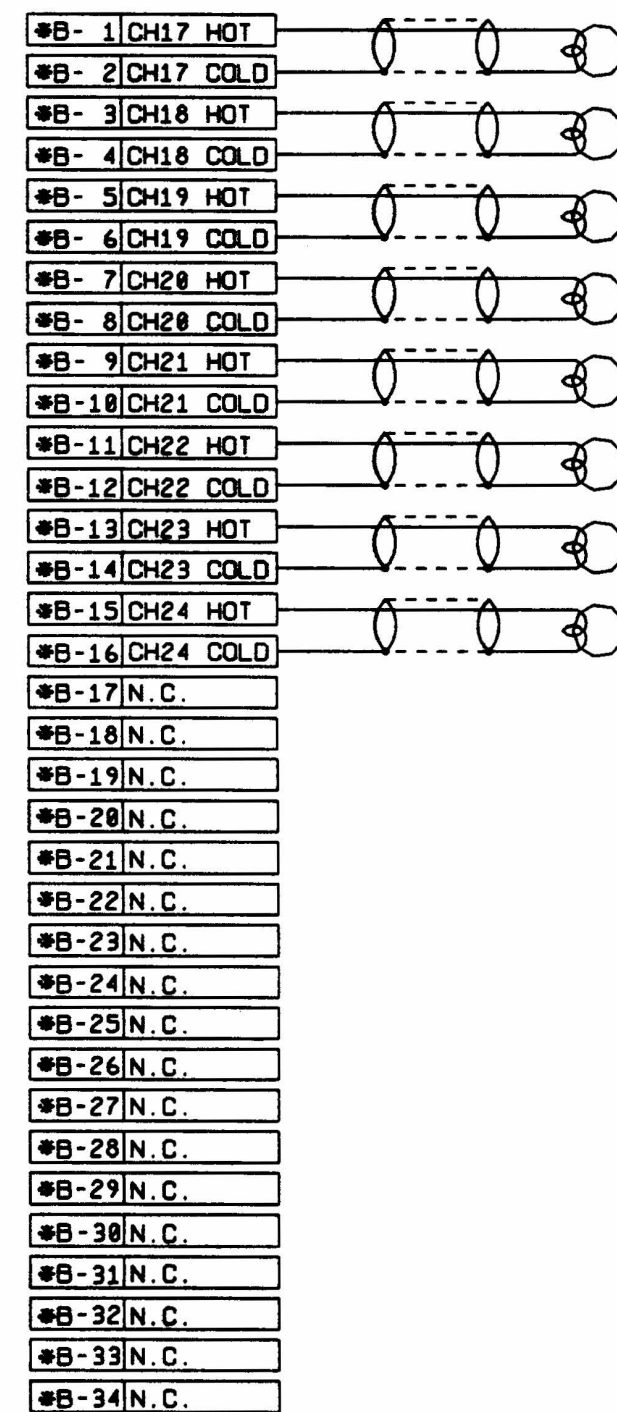
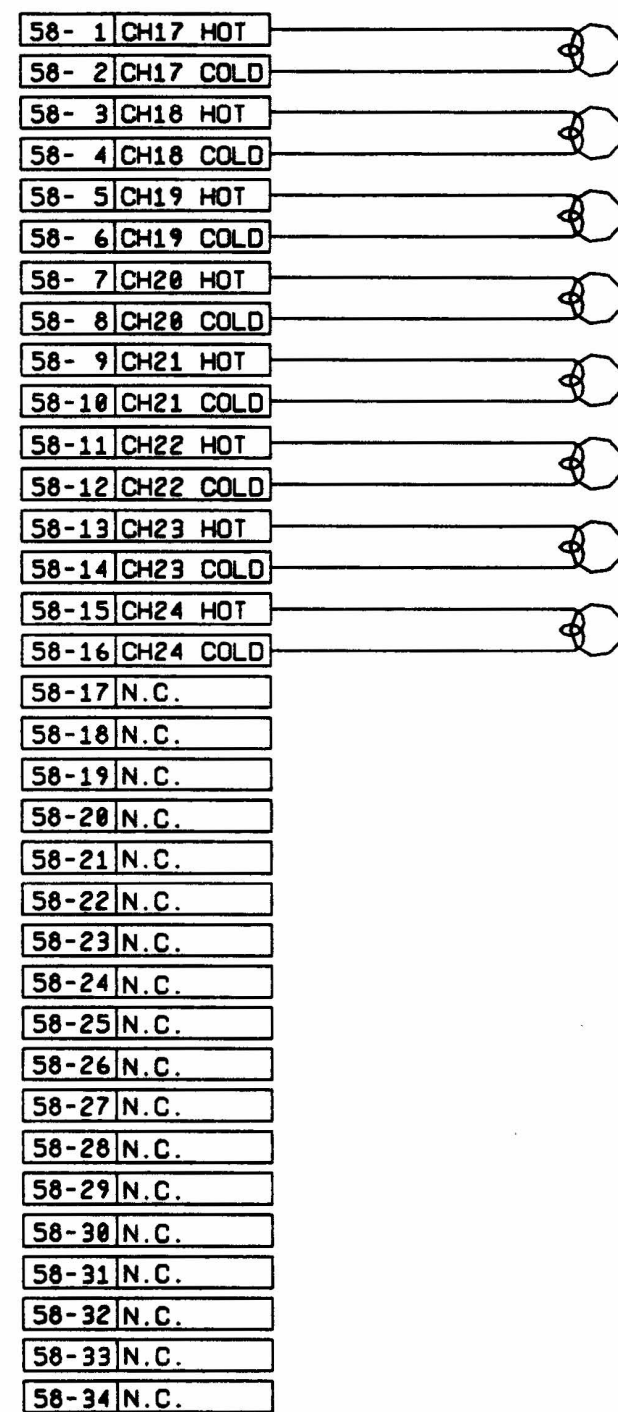
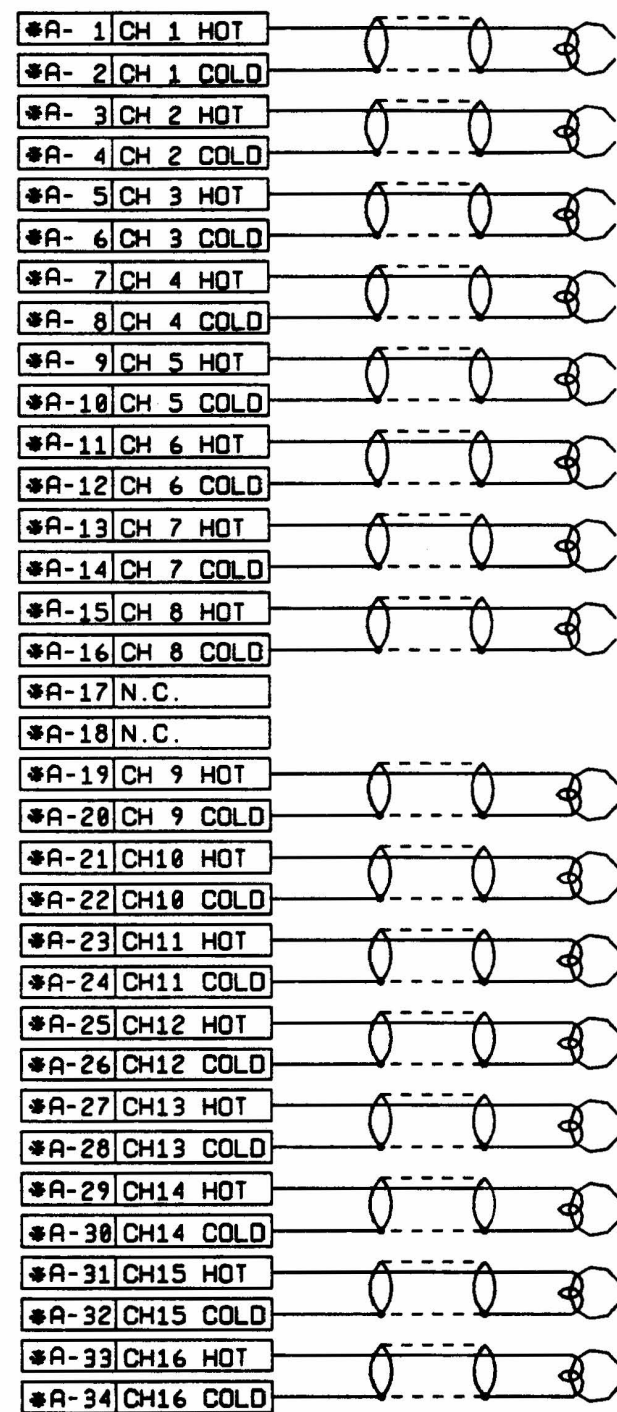
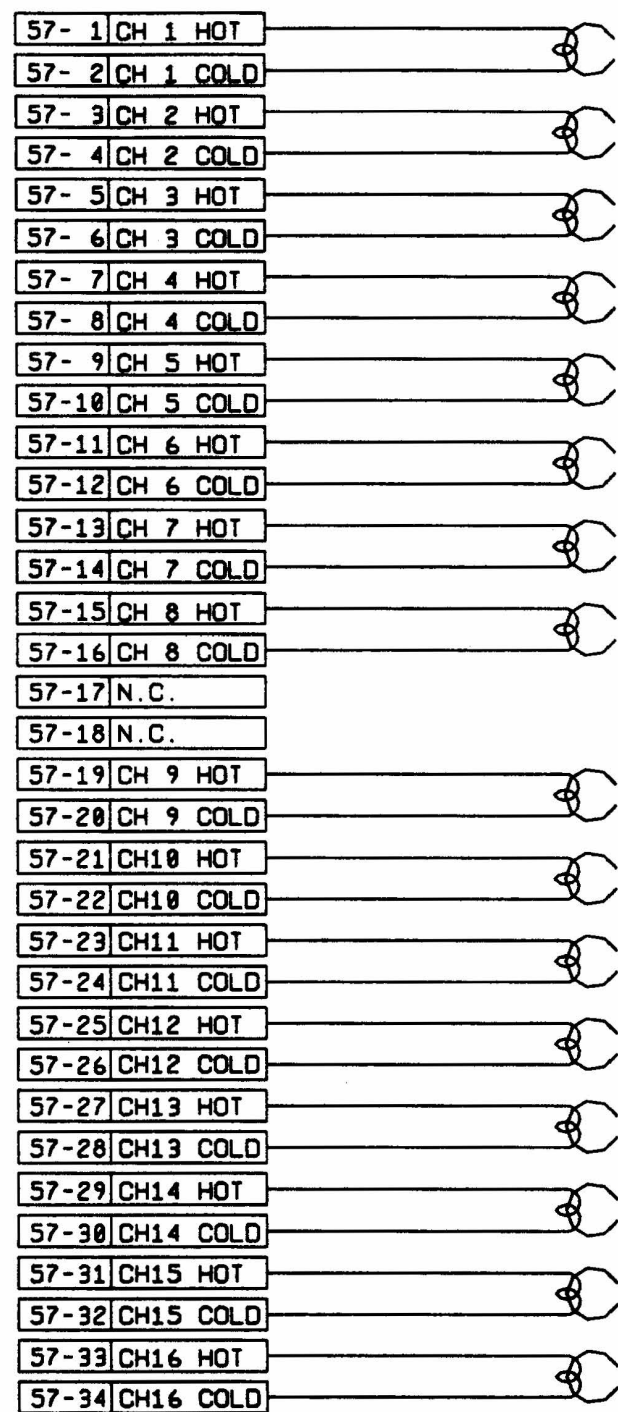

|      |      |        |
|------|------|--------|
| *A   | *B   | HEAD   |
| CN53 | CN54 | REPRO  |
| CN55 | CN56 | RECORD |

| CN     | TO HEAD | OTARI PART NO. | DESCRIPTION |
|--------|---------|----------------|-------------|
| 53, 54 | REPRO   | CN234130       | MR-34F      |
| 55, 56 | RECORD  | CN234130       | MR-34F      |
| 57, 58 | ERASE   | CN234129       | MR-34M      |

|          |         |                           |
|----------|---------|---------------------------|
| NAME     |         | HEAD WIRING DIAGRAM SHEET |
|          |         | (24CH) 1 OF 1             |
| PART NO. | KH6D00B |                           |
| APPLIED  | KH-60   |                           |

12542

A



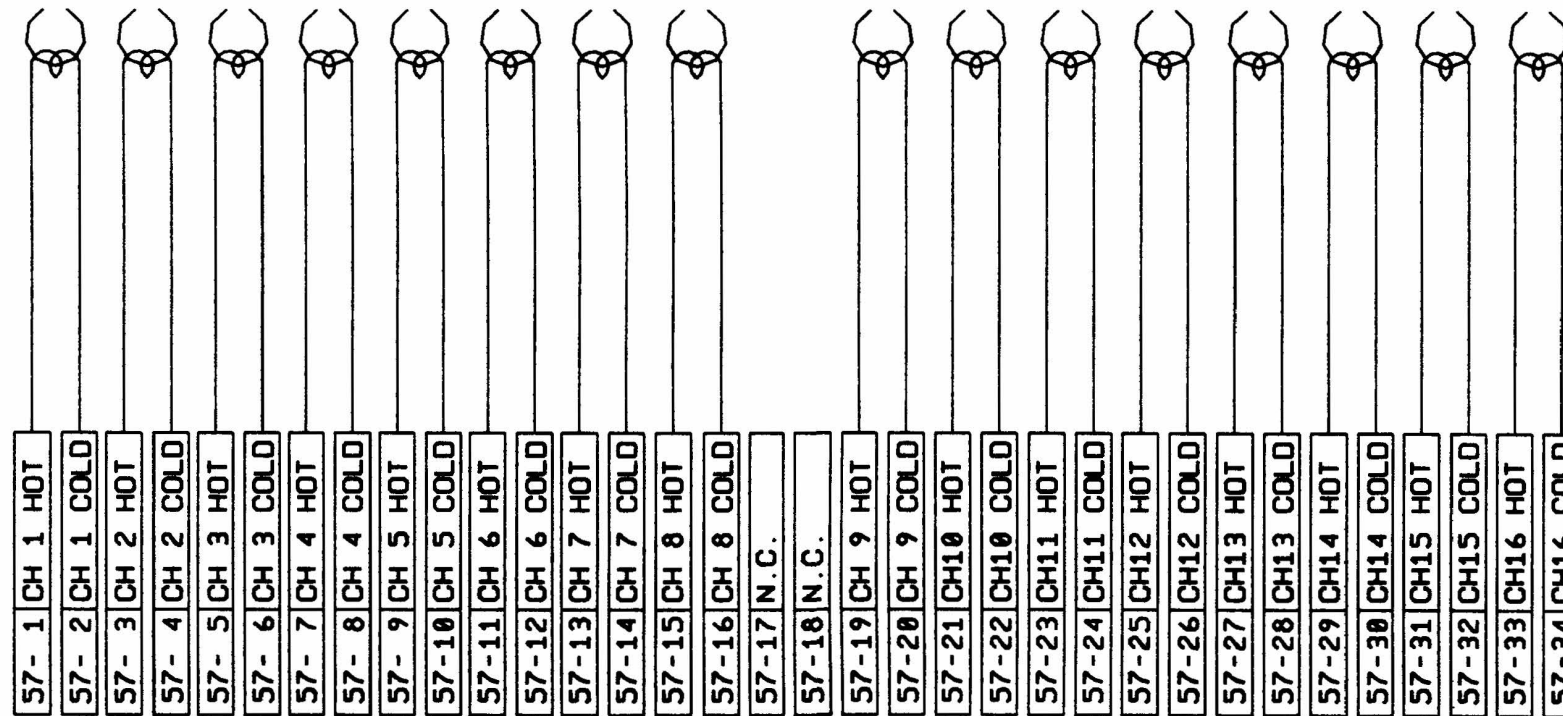
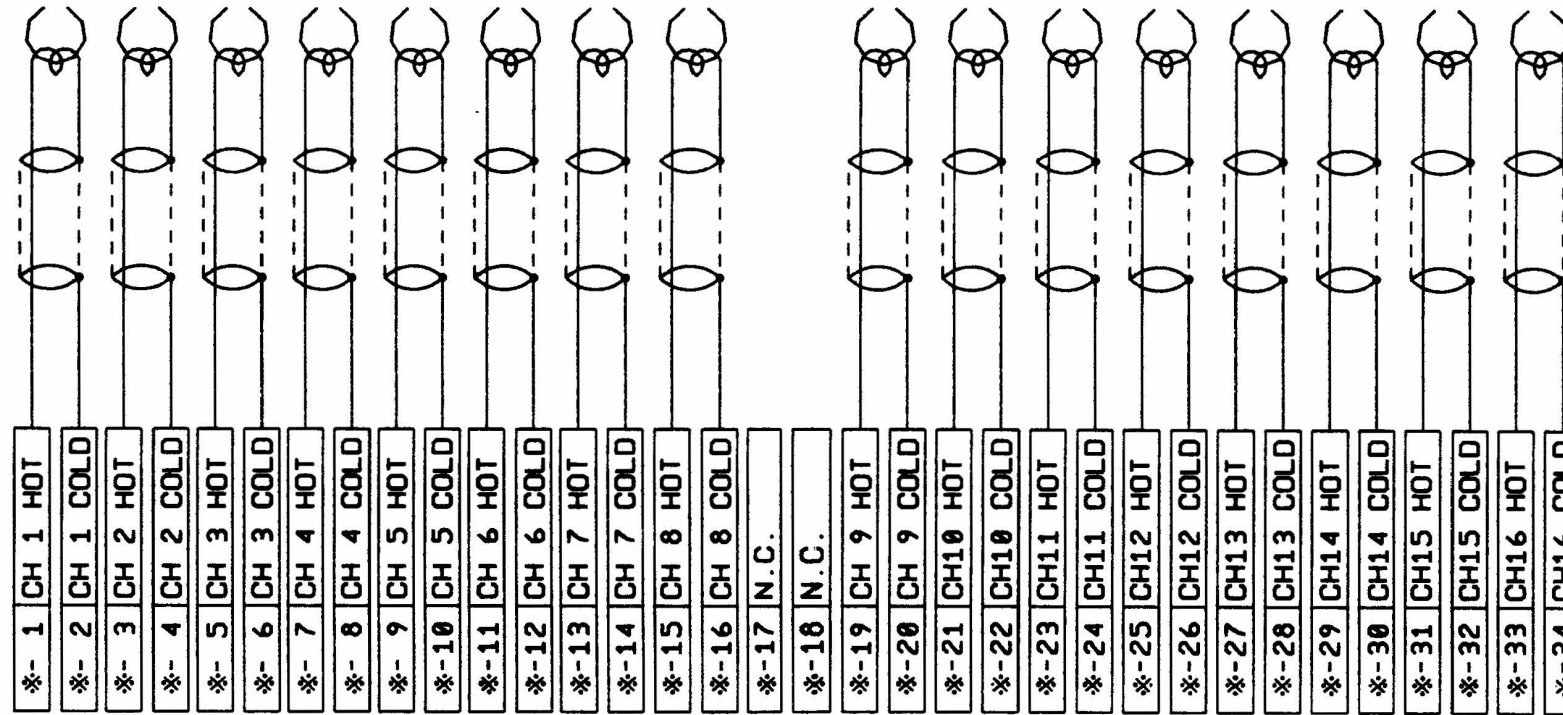

|      |        |
|------|--------|
| *    | HEAD   |
| CN53 | REPRO  |
| CN55 | RECORD |

| CN | TO HEAD | OTARI PART NO. | DESCRIPTION |
|----|---------|----------------|-------------|
| 53 | REPRO   | CN234130       | MR-34F      |
| 55 | RECORD  | CN234130       | MR-34F      |
| 57 | ERASE   | CN234129       | MR-34M      |

|          |                            |              |
|----------|----------------------------|--------------|
| NAME     | HEAD WIRING DIAGRAM (16CH) | SHEET 1 OF 1 |
| PART NO. | KH6E00B                    |              |
| APPLIED  | KH-6E                      |              |

12543  
 No. 340

A



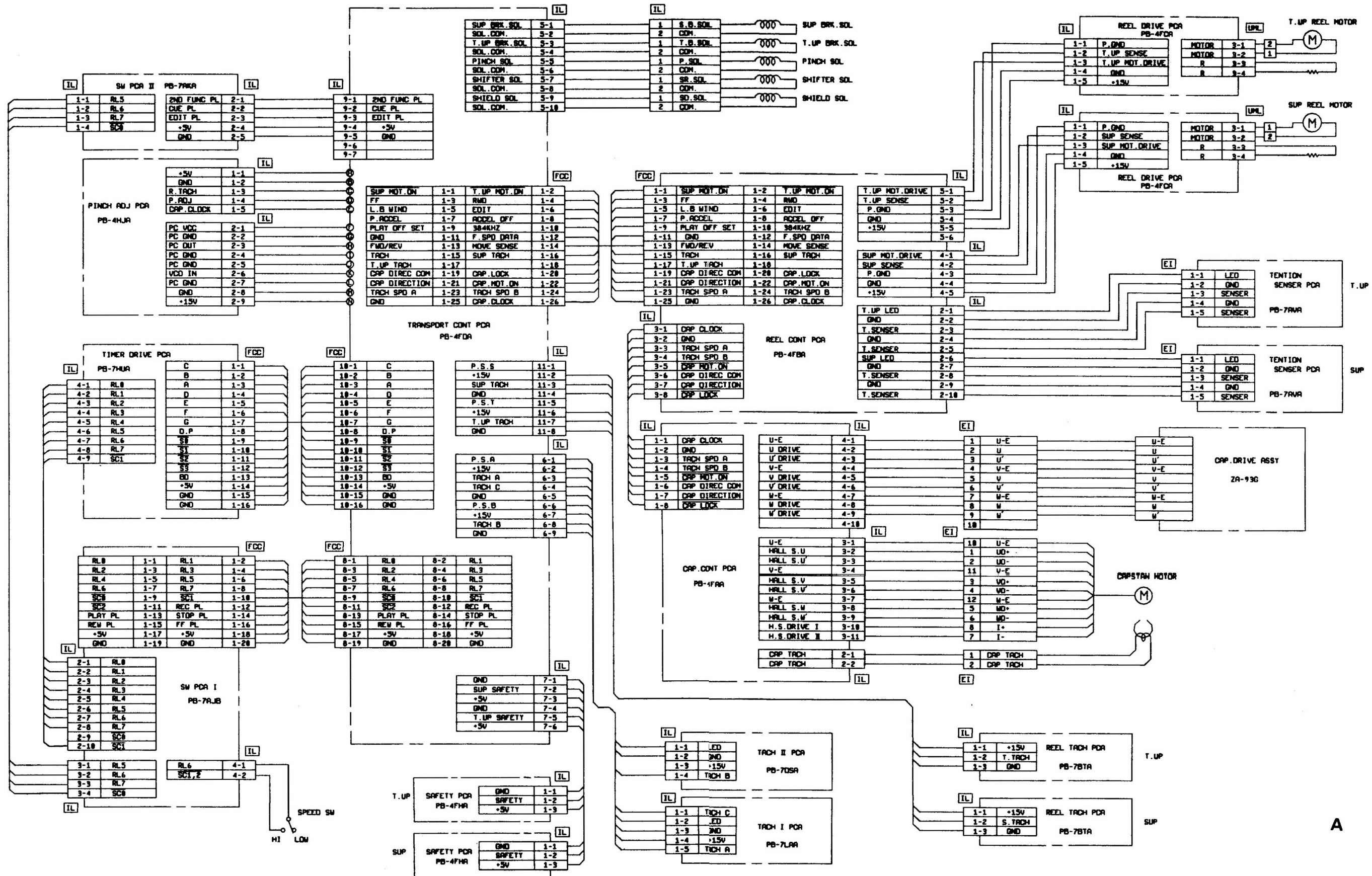

|          |                          |          |
|----------|--------------------------|----------|
| NAME     | TRANSPORT WIRING DIAGRAM | SHEET OF |
| PART NO. | T00370E                  |          |
| APPLIED  | T0037                    |          |

12544  
 12544



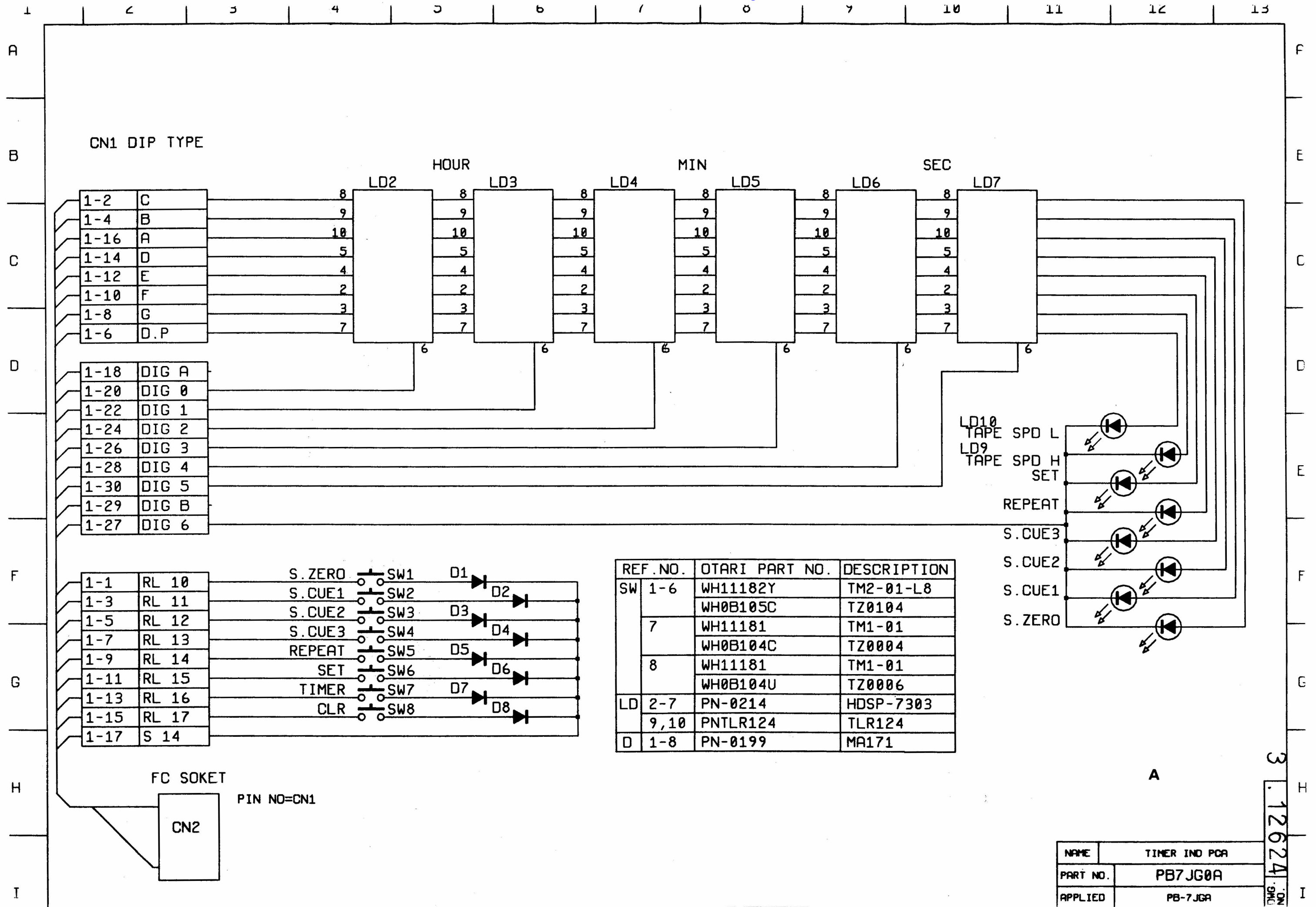

| REF. NO. | OTARI PART NO. | DESCRIPTION |           |
|----------|----------------|-------------|-----------|
| SW       | 1-6            | WH11182Y    | TM2-01-L8 |
|          |                | WH0B105C    | TZ0104    |
|          | 7              | WH11181     | TM1-01    |
|          |                | WH0B104C    | TZ0004    |
| LD       | 2-7            | PN-0214     | HDSP-7303 |
|          |                | 9,10        | PNTLR124  |
| D        | 1-8            | PN-0199     | MA171     |

|          |               |
|----------|---------------|
| NAME     | TIMER IND PCB |
| PART NO. | PB7JG0A       |
| APPLIED  | PB-7JGA       |

3. 12624

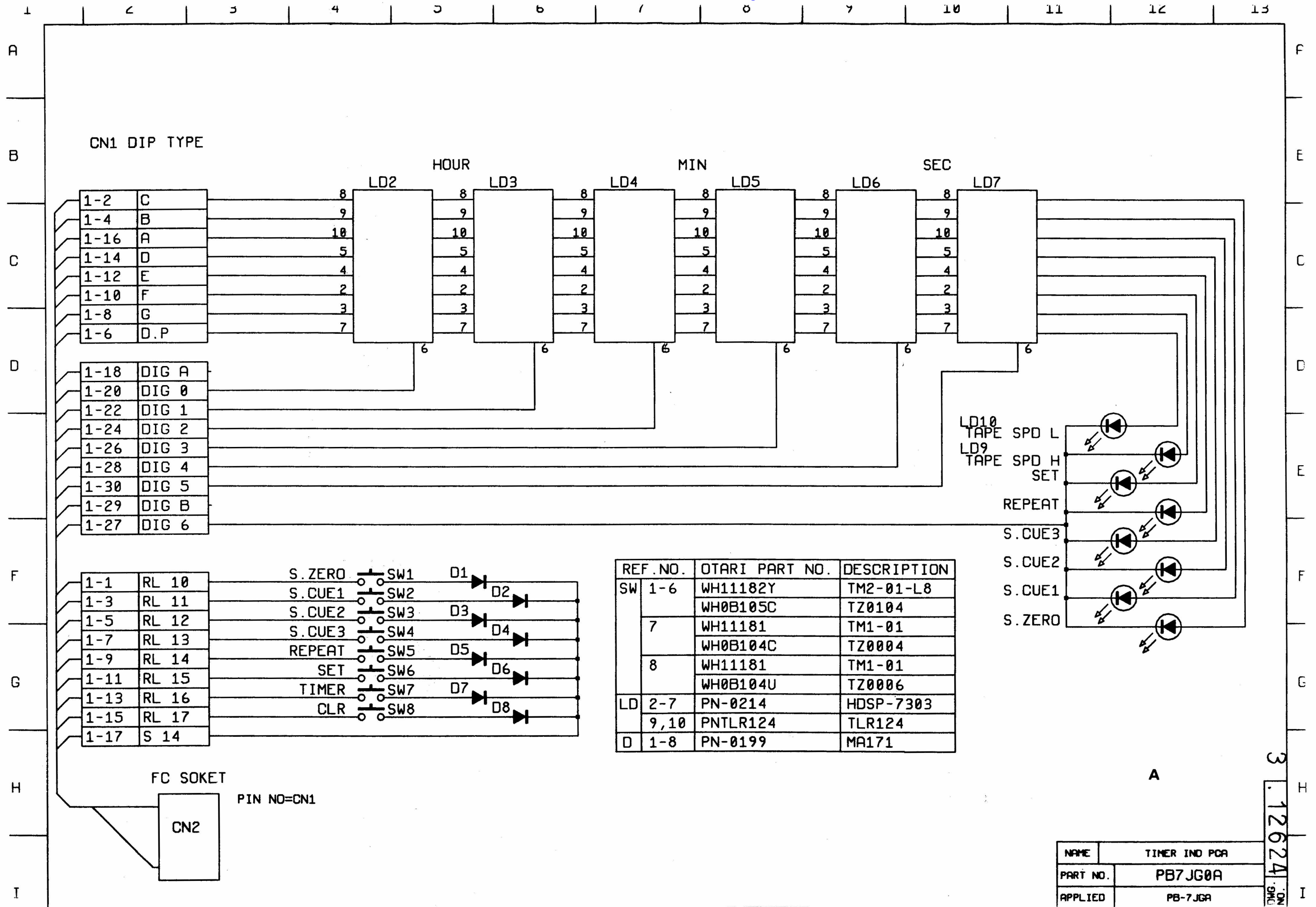

| REF. NO. | OTARI PART NO. | DESCRIPTION |           |
|----------|----------------|-------------|-----------|
| SW       | 1-6            | WH11182Y    | TM2-01-L8 |
|          |                | WH0B105C    | TZ0104    |
|          | 7              | WH11181     | TM1-01    |
|          |                | WH0B104C    | TZ0004    |
| LD       | 2-7            | PN-0214     | HDSP-7303 |
|          |                | 9,10        | PNTLR124  |
| D        | 1-8            | PN-0199     | MA171     |

|          |               |
|----------|---------------|
| NAME     | TIMER IND PCB |
| PART NO. | PB7JG0A       |
| APPLIED  | PB-7JGA       |

3. 12624



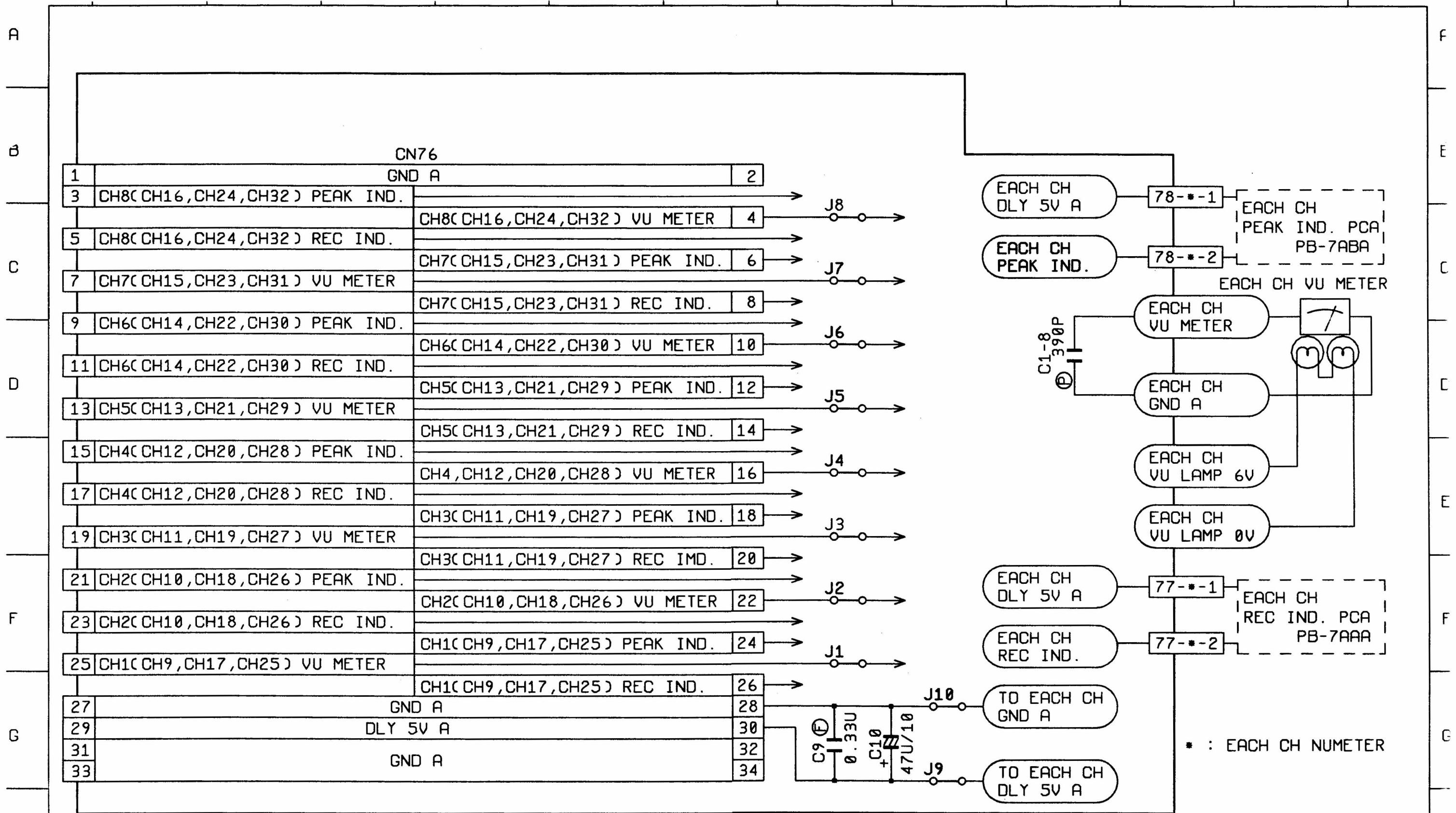

NOTES : UNLESS OTHERWISE SPECIFIED

- RESISTANCE VALUES ARE IN OHMS, ±W, 5%.
- CAPACITANCE VALUES ARE IN FARADS, 50V.
- CAPACITOR SYMBOL MARKS ARE AS FOLLOWS.

- ⊖ : ALUMINUM ELECTROLYTIC CAPACITOR.
- ⊕ : BIPOLAR ALUMINUM ELECTROLYTIC CAPACITOR.
- Ⓜ : MYLAR FILM CAPACITOR(±5%, 50V)
- Ⓢ : POLYSTYRENE FILM CAPACITOR(±5%, 50V)
- ⓐ : CERAMIC CAPACITOR.
- Ⓜ : MICA CAPACITOR(±5%)

- Ⓣ : TANTALUM ELECTROLYTIC CAPACITOR.
- Ⓟ : POLYPROPYLENE FILM CAPACITOR(±5%)
- Ⓛ : LOW LEAKAGE CURRENT ELECTROLYTIC CAPACITOR.
- Ⓞ : METALLIZED PAPER CAPACITOR(±10%)
- Ⓢ : SPARK KILLER.
- Ⓛ : SAFETY COMPONENT : REPLACE ONLY WITH THE SPECIFIED COMPONENT FOR SAFETY REASON.

|          |              |
|----------|--------------|
| NAME     | VU METER PCA |
| PART NO. | PB7HX0A      |
| APPLIED  | PB-7HXA      |

3.12519 ON

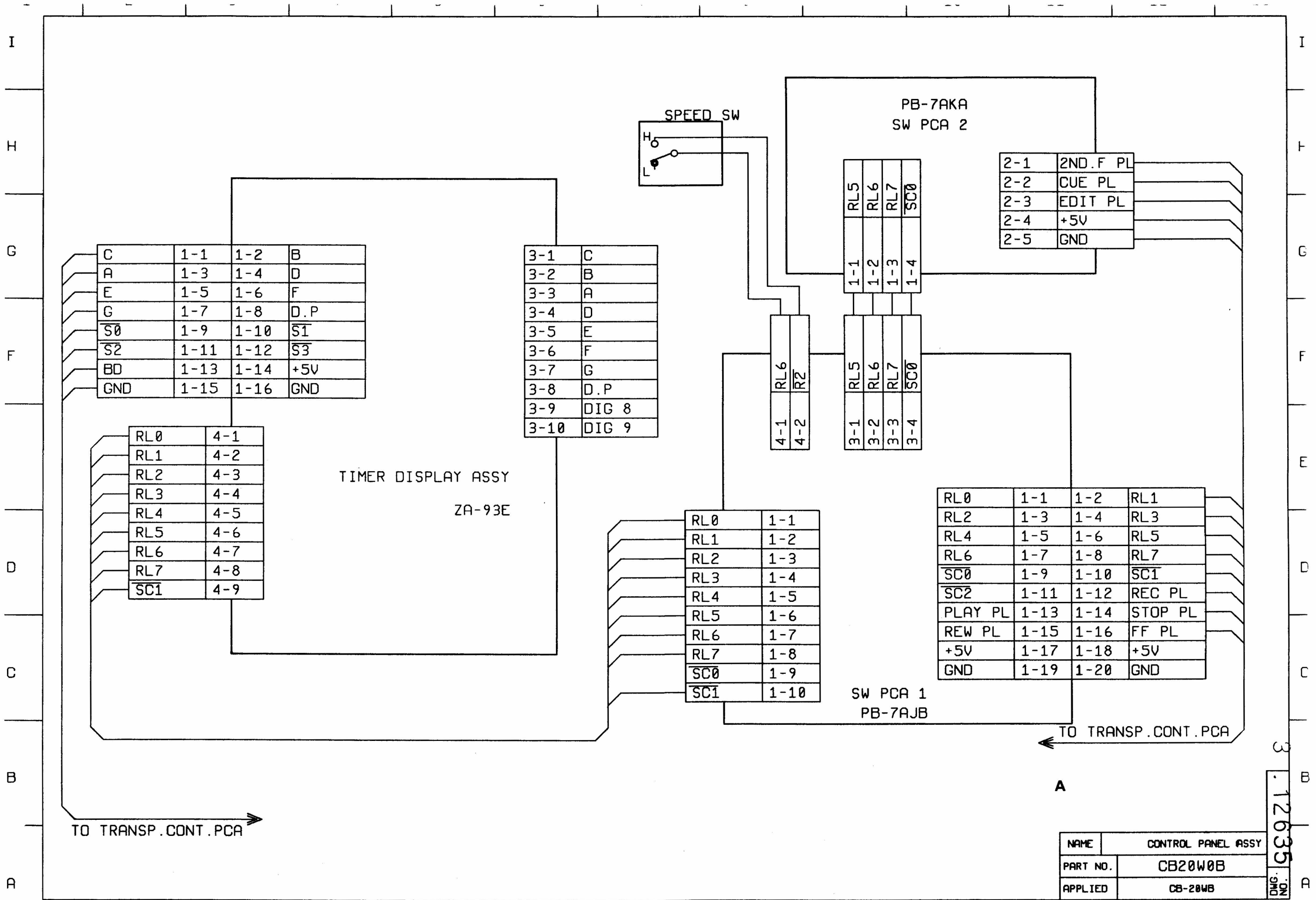

|          |                    |
|----------|--------------------|
| NAME     | CONTROL PANEL ASSY |
| PART NO. | CB20W0B            |
| APPLIED  | CB-20WB            |

DWG. NO. 12635



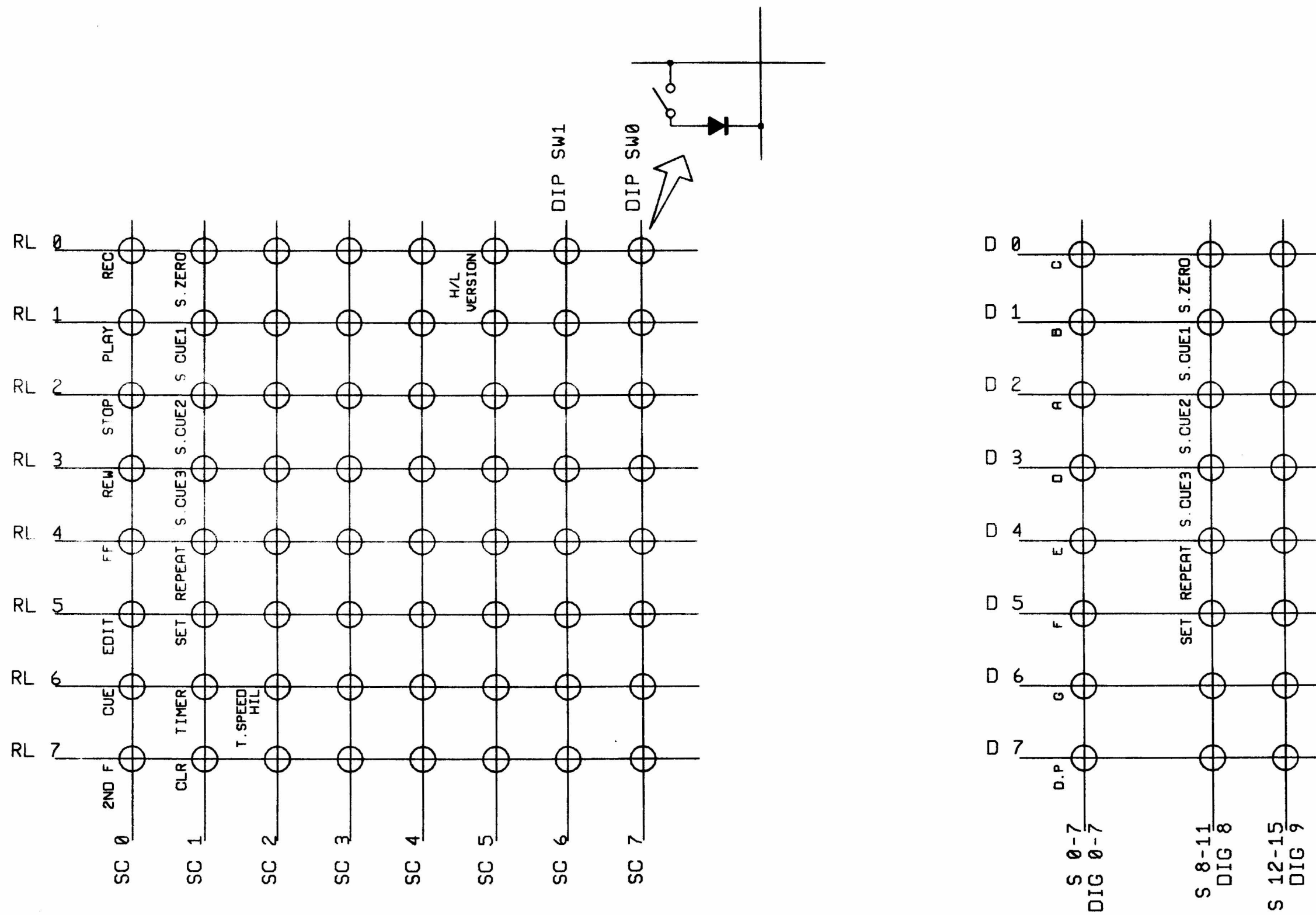

|          |                    |
|----------|--------------------|
| NAME     | CONTROL PANEL ASSY |
| PART NO. | CB20W0C            |
| APPLIED  | CB-20WC            |

3  
126371  
DWG NO.

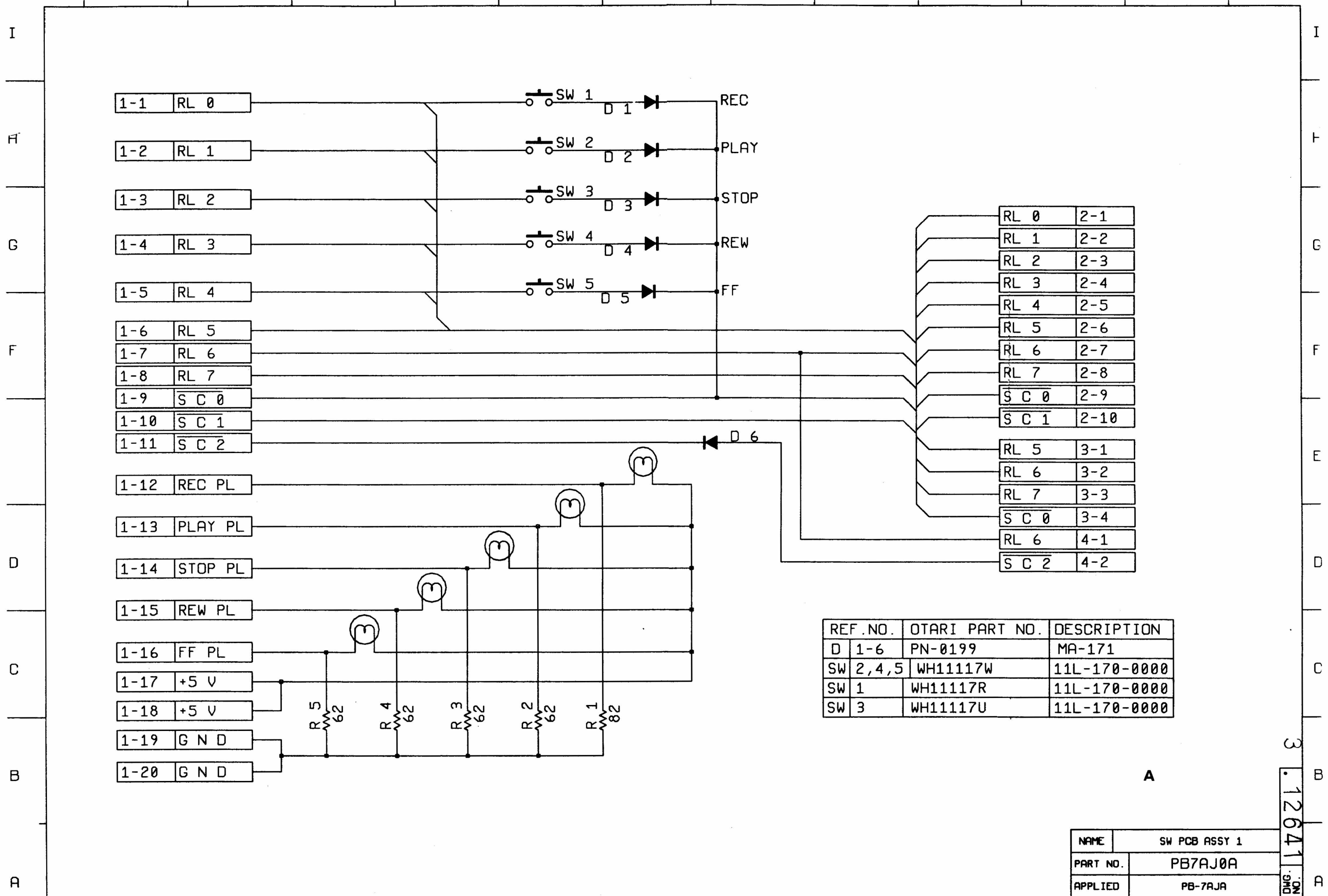

|          |               |
|----------|---------------|
| NAME     | SW PCB ASSY 1 |
| PART NO. | PB7AJ0A       |
| APPLIED  | PB-7AJA       |

3  
 .12641  
 DWG. NO.

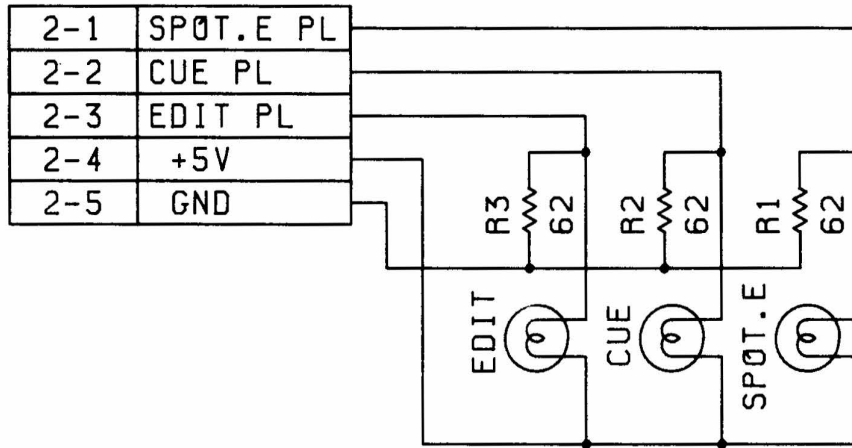
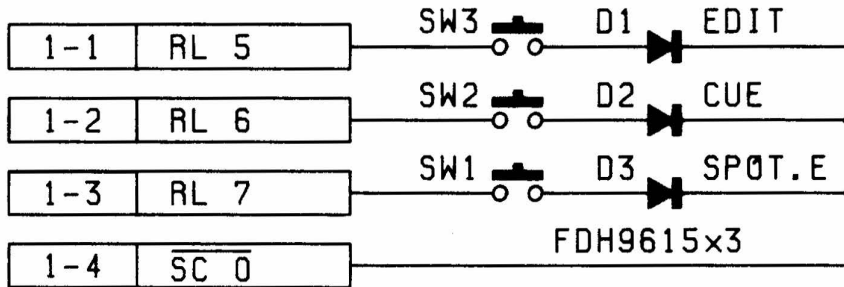

A

|          |                      |                       |
|----------|----------------------|-----------------------|
| NAME     | SW P.C.B. ASS'Y (II) | Dwg.<br>NO. 4 . 37429 |
| PART NO. | PB7AK0A              |                       |
| APPLIED  |                      |                       |

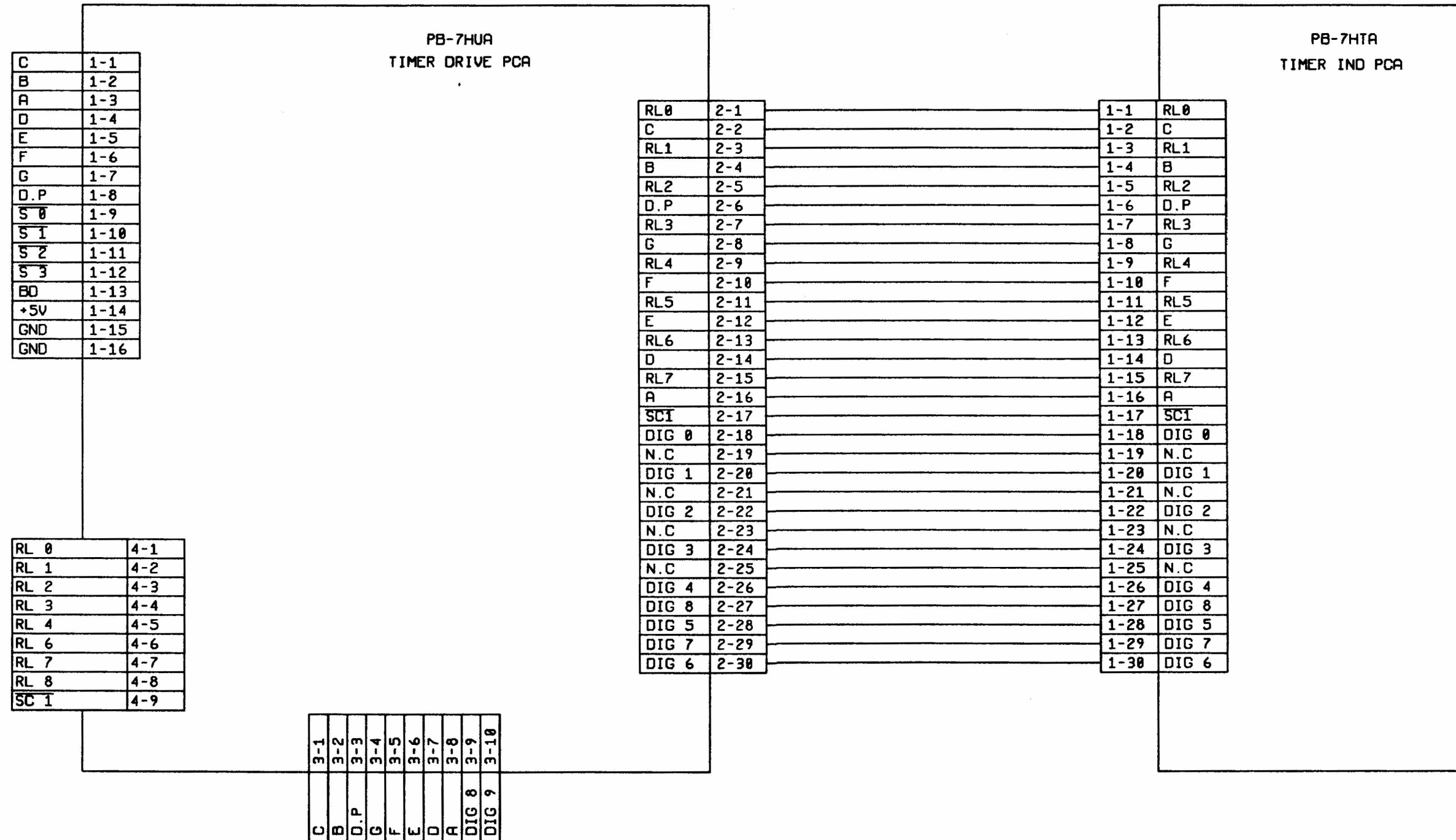

REV. C

|          |                 |                 |
|----------|-----------------|-----------------|
| NAME     | TIMER DISP ASSY | SHEET<br>1 OF 1 |
| PART NO. | ZA93E0A         |                 |
| APPLIED  | ZA-93EA         |                 |

DWG. NO. 3-12645



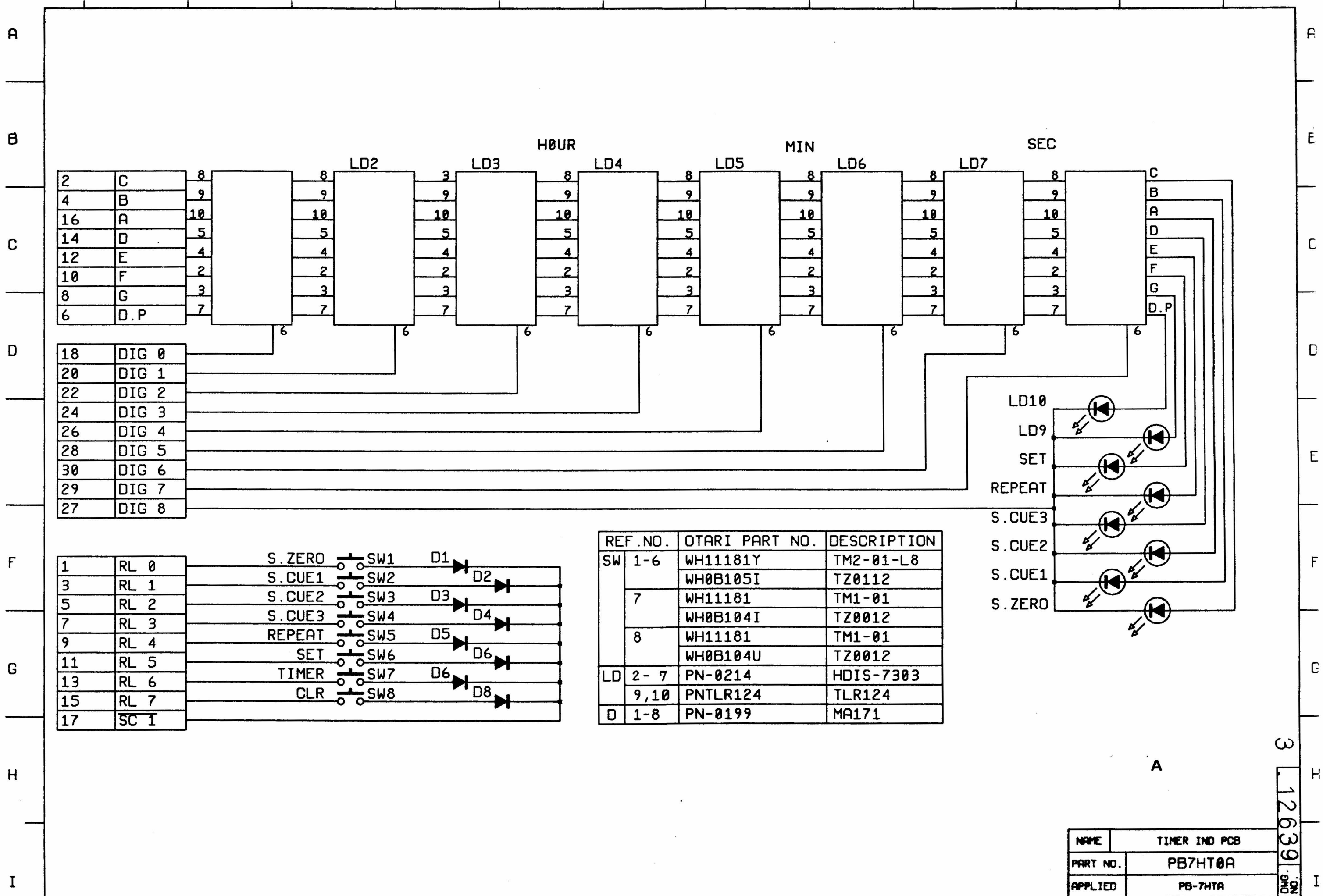

|    |     |    |
|----|-----|----|
| 2  | C   | 8  |
| 4  | B   | 9  |
| 16 | A   | 10 |
| 14 | D   | 5  |
| 12 | E   | 4  |
| 10 | F   | 2  |
| 8  | G   | 3  |
| 6  | D.P | 7  |

|    |       |
|----|-------|
| 18 | DIG 0 |
| 20 | DIG 1 |
| 22 | DIG 2 |
| 24 | DIG 3 |
| 26 | DIG 4 |
| 28 | DIG 5 |
| 30 | DIG 6 |
| 29 | DIG 7 |
| 27 | DIG 8 |

|    |      |
|----|------|
| 1  | RL 0 |
| 3  | RL 1 |
| 5  | RL 2 |
| 7  | RL 3 |
| 9  | RL 4 |
| 11 | RL 5 |
| 13 | RL 6 |
| 15 | RL 7 |
| 17 | SC 1 |

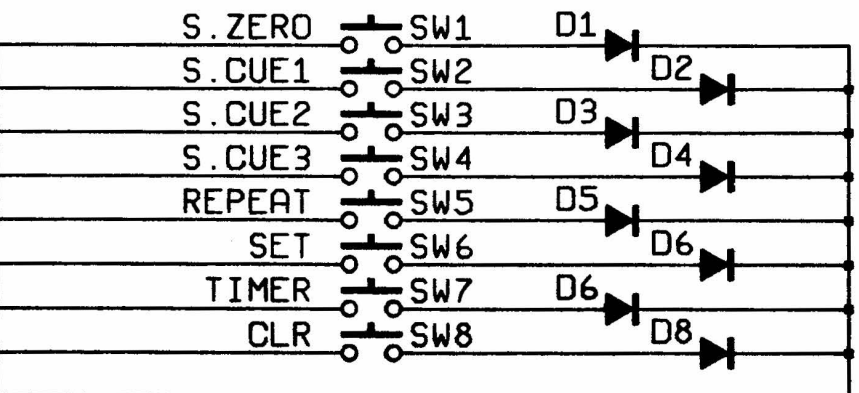

| REF. NO. | QTARI PART NO. | DESCRIPTION |
|----------|----------------|-------------|
| SW 1-6   | WH11181Y       | TM2-01-L8   |
|          | WH0B105I       | TZ0112      |
| 7        | WH11181        | TM1-01      |
|          | WH0B104I       | TZ0012      |
| 8        | WH11181        | TM1-01      |
|          | WH0B104U       | TZ0012      |
| LD 2-7   | PN-0214        | HDIS-7303   |
|          | 9,10           | PNTLR124    |
| D 1-8    | PN-0199        | MA171       |

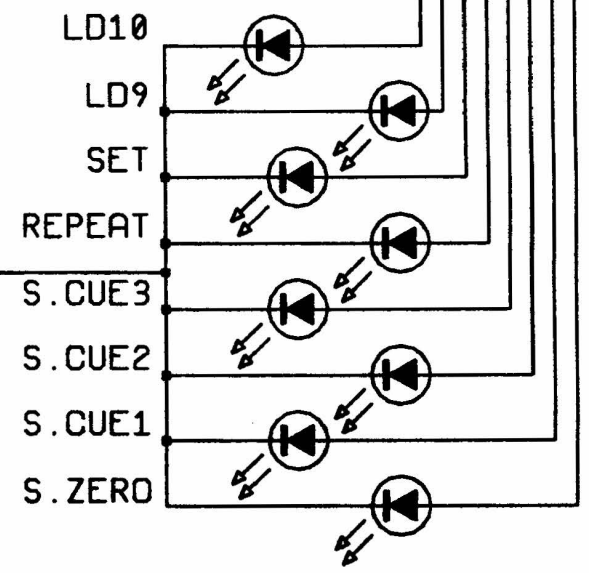

|          |               |
|----------|---------------|
| NAME     | TIMER IND PCB |
| PART NO. | PB7HT0A       |
| APPLIED  | PB-7HTA       |

3 12639 .001



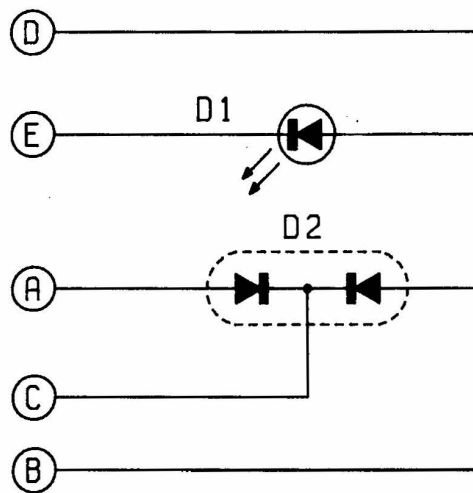

| REF. NO. | QTARI PART NO. | DESCRIPTION       |
|----------|----------------|-------------------|
| D        | 1              | PNLN62S LN62S     |
|          | 2              | PN-0213 MI-33H-2D |

**A**

|          |                   |                    |
|----------|-------------------|--------------------|
| NAME     | TENSION DET ASS'Y | Dwg. No. 4 . 37460 |
| PART NO. | SR1W00A           |                    |
| APPLIED  | SR-1W             |                    |



A  
B  
C  
D  
E  
F  
G  
H  
I

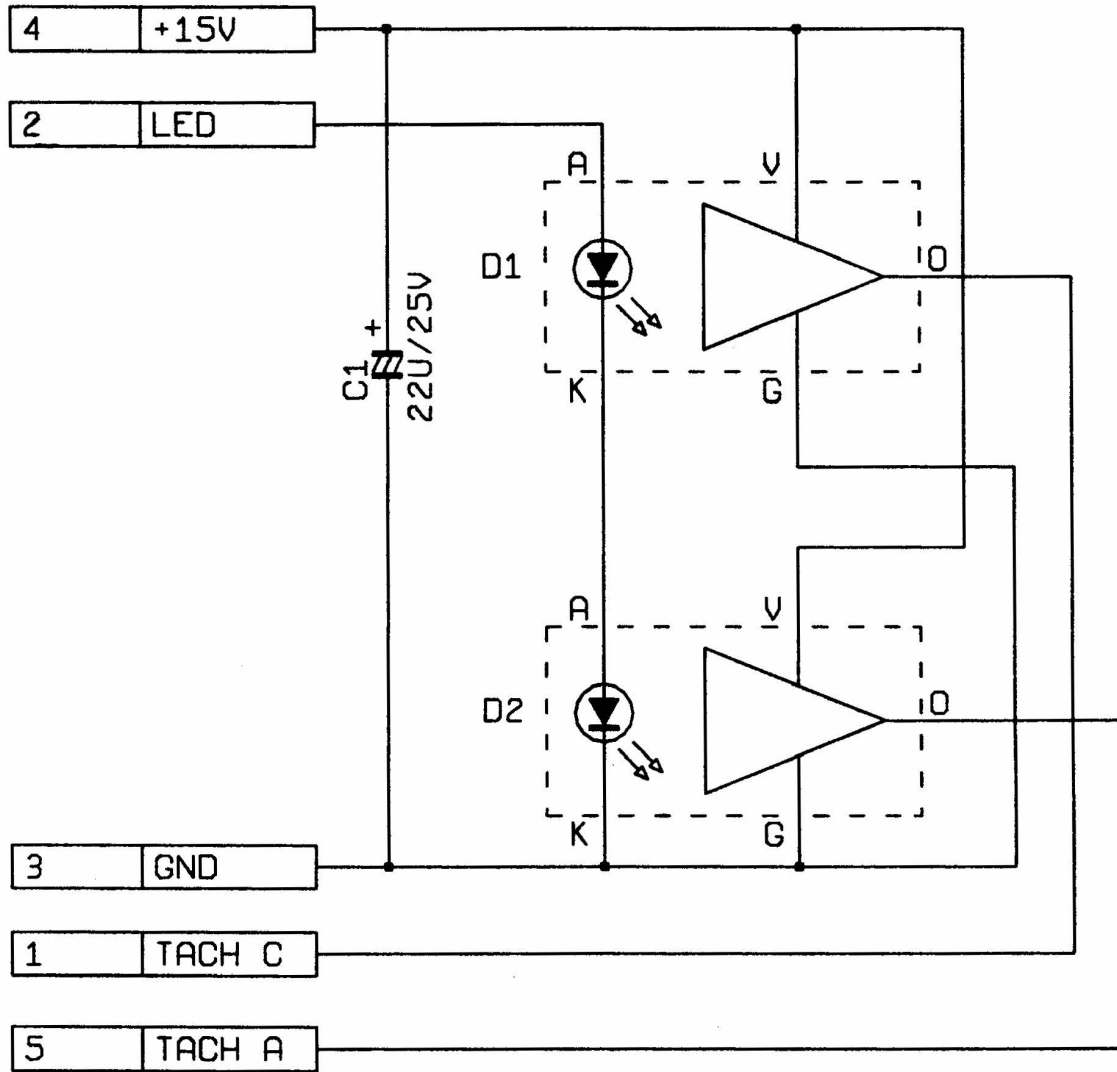

| REF. NO. | OTARI PART NO. | DESCRIPTION |
|----------|----------------|-------------|
| D 1.2    | PN-0212        | EE-SX401    |

|          |                   |
|----------|-------------------|
| NAME     | ROLLER TACH I PCB |
| PART NO. | PB7LA0A           |
| APPLIED  | PB-7LAA           |

4  
42942  
20



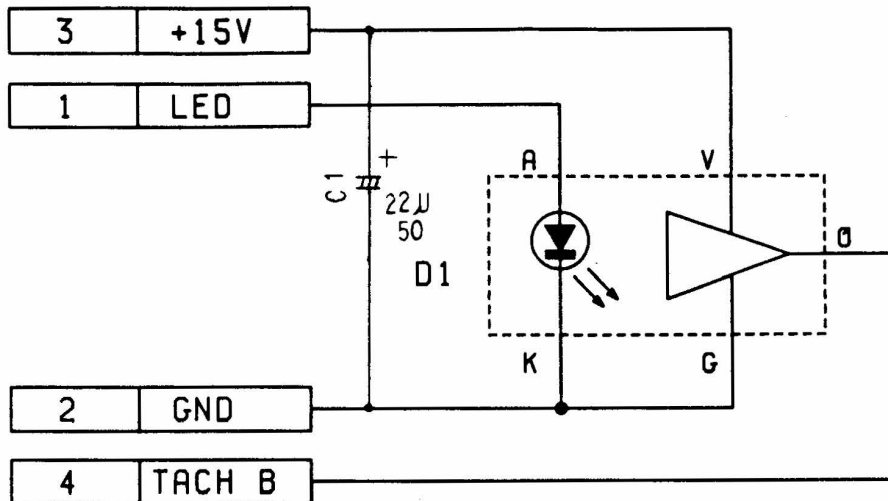

| REF. NO. | OTARI PART NO. | DESCRIPTION |
|----------|----------------|-------------|
| D 1      | PN-0212        | EE-SX401    |

TYPE NO. (A) (1)  
( ) AT THE END

|          |                    |                    |
|----------|--------------------|--------------------|
| NAME     | ROLLER TACH II PCA | Dwg. No. 4 . 42330 |
| PART NO. | PB7DS0A            |                    |
| APPLIED  | PB-70SA            |                    |

A  
B  
C  
D  
E  
F  
G  
H  
I

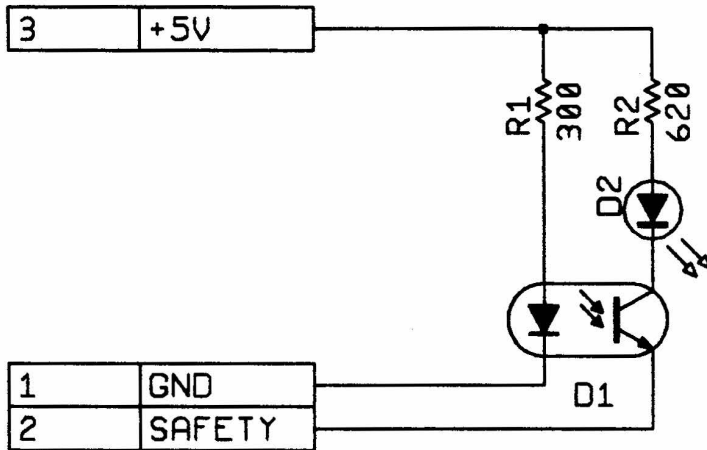

| REF. NO | OTARI | PART NO  | DESCRIPTION |
|---------|-------|----------|-------------|
| D       | 1     | PN-0227  | EE-SJ3W-B   |
|         | 2     | PNTLG124 | TLG124      |

|          |            |
|----------|------------|
| NAME     | SAFETY PCA |
| PART NO. | PB4FH0A    |
| APPLIED  | PB-4FHA    |

4  
42934  
DWG. NO.

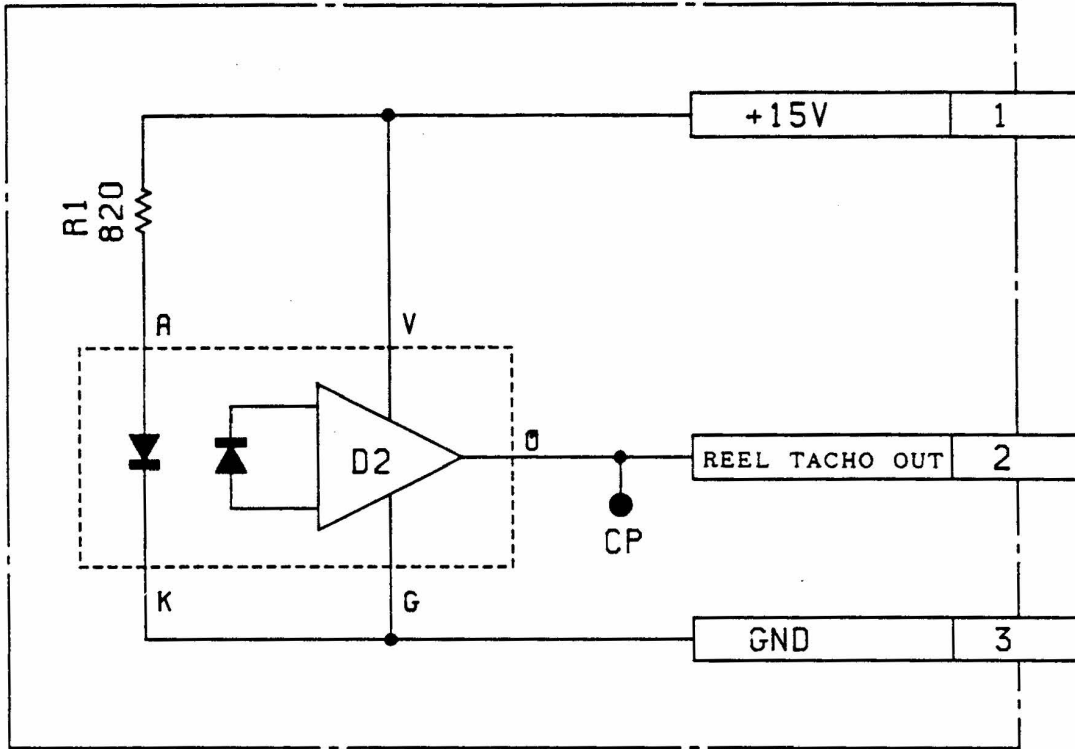

| REF. NO. | OTARI PART NO. | DESCRIPTION      |
|----------|----------------|------------------|
| D        |                |                  |
|          | 2              | PN-0211 EE-SX301 |

TYPE NO. (A) TO  
( ) AT THE END

|          |               |
|----------|---------------|
| NAME     | REEL TACH PCA |
| PART NO. | PB7MVOA       |
| APPLIED  | PB-7MVA       |

Dwg. No. 4-43028

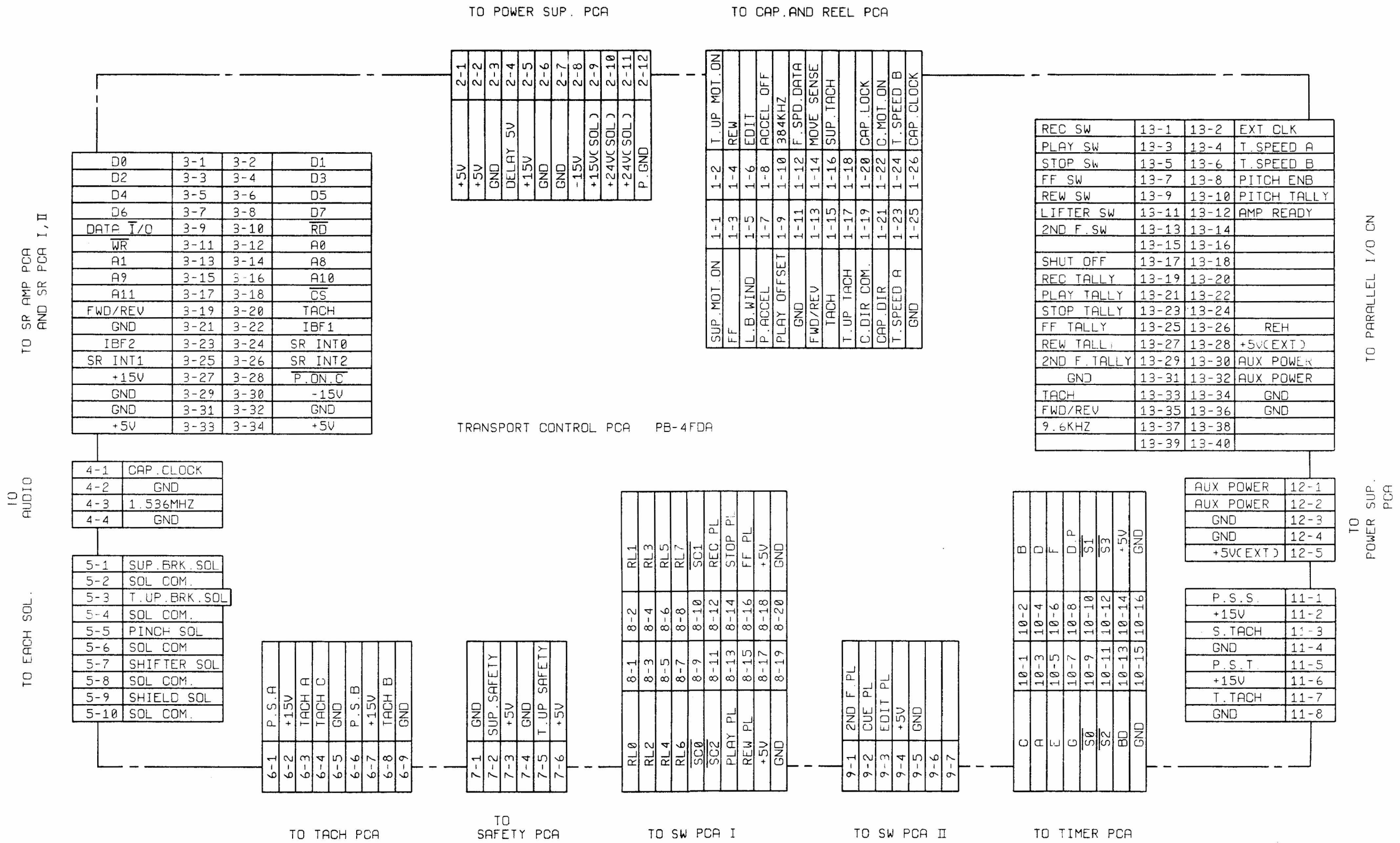

A

|          |                              |          |
|----------|------------------------------|----------|
| NAME     | TRANSPORT CONNECTION DIAGRAM | SHEET OF |
| PART NO. | PB4FD0B                      |          |
| APPLIED  | PB-4FDB                      |          |

3 . 12633



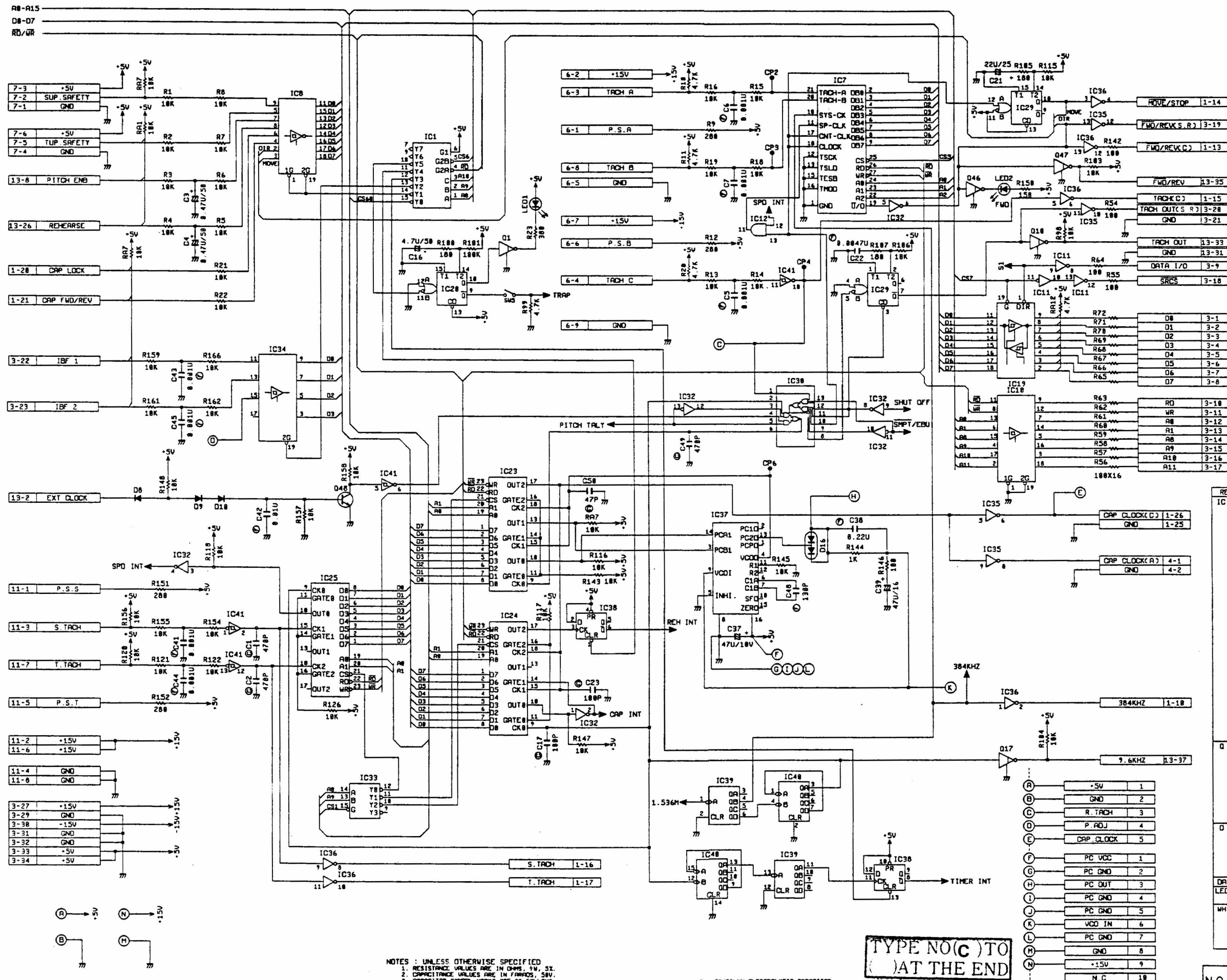

NOTES : UNLESS OTHERWISE SPECIFIED  
 1. RESISTANCE VALUES ARE IN OHMS,  $\text{K}$ ,  $\text{M}$ .  
 2. CAPACITANCE VALUES ARE IN FARADS,  $\text{M}$ ,  $\text{N}$ .  
 3. CAPACITOR SYMBOL MARKS ARE AS FOLLOWS:  
 - ALUMINUM ELECTROLYTIC CAPACITOR.  
 - BIPOLAR ALUMINUM ELECTROLYTIC CAPACITOR.  
 - NYLON FILM CAPACITOR (5%  $\pm$  50V).  
 - POLYESTER FILM CAPACITOR (5%  $\pm$  50V).  
 - CERAMIC CAPACITOR.  
 - MICR CAPACITOR (5%)  
 - TANTALUM ELECTROLYTIC CAPACITOR.  
 - POLYPROPYLENE FILM CAPACITOR (5%)  
 - LOW LEAKAGE CURRENT ELECTROLYTIC CAPACITOR.  
 - METALLIZED PAPER CAPACITOR (5%)  
 - SAFETY KILLER.  
 - SAFETY COMPONENT: REPLACE ONLY WITH THE SPECIFIED COMPONENT FOR SAFETY REASON.

TYPE NO(C) TO  
 AT THE END

| REFERENCE NO.                                  | OTARI PART NO. | DESCRIPTION  |
|--|----------------|--------------|
| IC 1, 15, 17                                   | IC136          | TC74HC138    |
| 2  | I-0093         | D27256       |
| 3  | IMS18085       | MSH80C85ARS  |
| 4  | IC084P         | TC74HC84P    |
| 5, 11, 35, 36                                  | IC084          | TC74HC84P    |
| 6  | IMS18279       | MSL8279P-5   |
| 7  | I-0112         | I-0112       |
| 8, 21  | IC548          | TC74HC548P   |
| 9  | I-0002         | NJM4558D-0   |
| 10, 34   | IC244          | TC74HC244    |
| 12   | IC088          | TC74HC08P    |
| 13   | IC373          | TC74HC373P   |
| 14   | I-0075         | MM6116LP-4   |
| 16   | IC32           | TC74HC32     |
| 18, 22   | IMS18255       | MSH82C55AP-5 |
| 19   | IC245          | TC74HC245P   |
| 20, 29   | IMC14538       | MC14538B     |
| 23, 24, 25                                     | IMS18254       | MSH82C54P    |
| 27, 28, 32                                     | IMC14067       | MC14067B     |
| 30   | IC51P          | TC74HC51P    |
| 31   | IC148          | TC74HC148P   |
| 33   | IC139          | TC74HC139    |
| 37   | IC046          | TC74HC046P   |
| 26, 30   | IC074          | TC74HC74P    |
| 39   | IC393          | TC74HC393P   |
| 40   | IC390          | TC74HC390    |
| 41   | IMC14584       | MC14584      |
| Q 1, 10, 11, 14, 15, 34-37, 40, 47, 54, 55, 17 | Q-0008         | UN1211       |
| 2-9  | Q-0011         | RN1205       |
| 12   | QA1110R        | 2SA1108R     |
| 13   | QC2590R        | 2SC2590R     |
| 30   | Q25J122        | 2SJ122       |
| 39, 49, 53                                     | QA1820Y        | 2SA1820Y     |
| 40   | QC1815BL       | 2SC1815BL    |
| D 1  | PN-0264        | ERA02-004    |
| 2, 8, 10, 11                                   | PN-0199        | HA171(TP)    |
| 3, 5, 4  | PN-0257        | SM1-XN02     |
| 6  | PN05B15        | DSB15        |
| 16   | PN-0230        | MC931        |
| DA 1, 2  | PNAL8CS        | NAL8CS       |
| LED 1  | PNTL124        | TL124        |
| 2  | PNTL124        | TL124        |
| WH 1   | WH1101         | TM102        |
| 2  | WH0104R        | TZ-0002      |
| 3, 4   | WH31031        | RS10-2M      |
|  | WH90012        | R60-0102     |
|  | WH91023        | OSS-101      |

|          |                    |              |
|----------|--------------------|--------------|
| NAME     | TRANSPORT CONT PCA | SHEET 1 OF 2 |
| PART NO. | PB4FD0A            |              |
| APPLIED  | PB-4F0A            |              |

DWG. NO. 3-12691



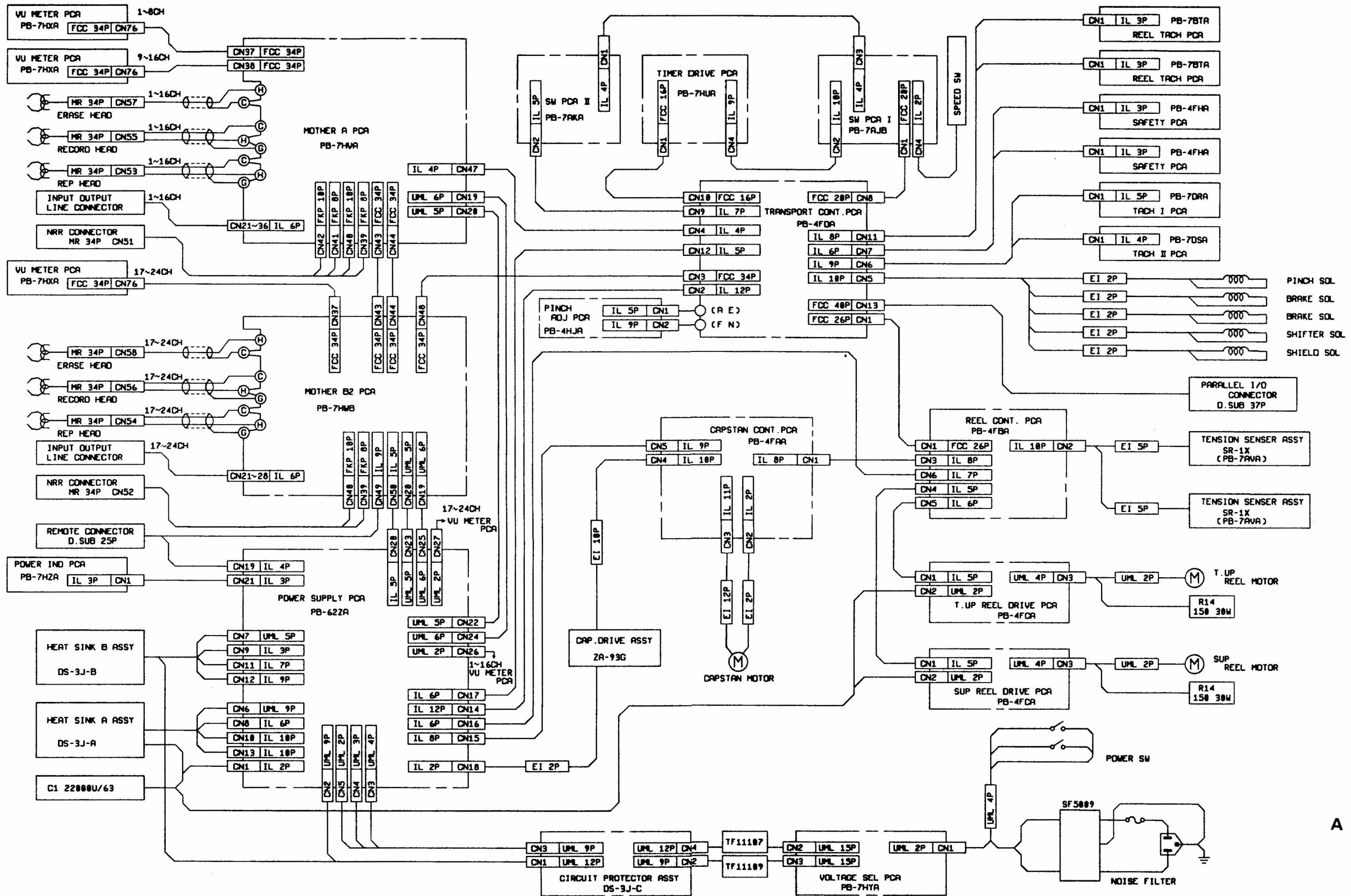

|          |                          |             |
|----------|--------------------------|-------------|
| NAME     | WIRING DIAGRAM<br>(24CH) | SHEET<br>OF |
| PART NO. | T00370C                  |             |
| APPLIED  | MX-80-24                 |             |

12539  
 12539







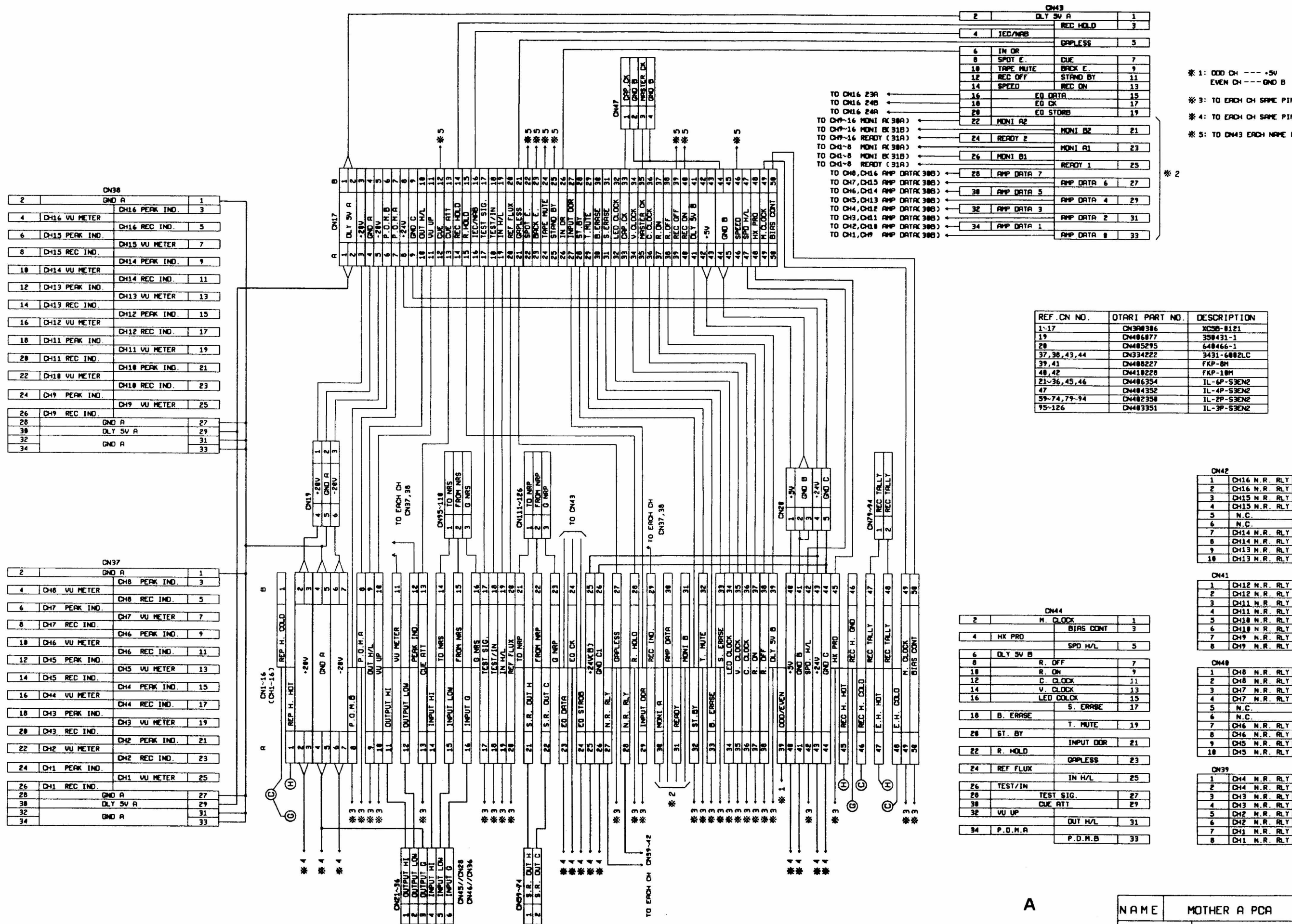

| REF. CN NO.    | OTARI PART NO. | DESCRIPTION |
|----------------|----------------|-------------|
| 1-17           | CN300306       | XC50-8121   |
| 19             | CN406077       | 350431-1    |
| 20             | CN405295       | 640466-1    |
| 37, 38, 43, 44 | CN334222       | 3431-600ZLC |
| 39, 41         | CN406227       | FKP-8H      |
| 40, 42         | CN410228       | FKP-10H     |
| 21-36, 45, 46  | CN406354       | 1L-6P-S3CN2 |
| 47             | CN404352       | 1L-4P-S3CN2 |
| 59-74, 79-94   | CN402350       | 1L-2P-S3CN2 |
| 95-126         | CN403351       | 1L-3P-S3CN2 |

\* 1: ODD CH --- +5V  
EVEN CH --- GND B

\* 3: TO EACH CH SAME PIN NO. AND CN44

\* 4: TO EACH CH SAME PIN NO.

\* 5: TO CN43 EACH NAME PIN NO.

| CN42 |               |  |
|------|---------------|--|
| 1    | CH16 N.R. RLY |  |
| 2    | CH16 N.R. RLY |  |
| 3    | CH15 N.R. RLY |  |
| 4    | CH15 N.R. RLY |  |
| 5    | N.C.          |  |
| 6    | N.C.          |  |
| 7    | CH14 N.R. RLY |  |
| 8    | CH14 N.R. RLY |  |
| 9    | CH13 N.R. RLY |  |
| 10   | CH13 N.R. RLY |  |

| CN41 |               |  |
|------|---------------|--|
| 1    | CH12 N.R. RLY |  |
| 2    | CH12 N.R. RLY |  |
| 3    | CH11 N.R. RLY |  |
| 4    | CH11 N.R. RLY |  |
| 5    | CH10 N.R. RLY |  |
| 6    | CH10 N.R. RLY |  |
| 7    | CH9 N.R. RLY  |  |
| 8    | CH9 N.R. RLY  |  |

| CN40 |              |  |
|------|--------------|--|
| 1    | CH8 N.R. RLY |  |
| 2    | CH8 N.R. RLY |  |
| 3    | CH7 N.R. RLY |  |
| 4    | CH7 N.R. RLY |  |
| 5    | N.C.         |  |
| 6    | N.C.         |  |
| 7    | CH6 N.R. RLY |  |
| 8    | CH6 N.R. RLY |  |
| 9    | CH5 N.R. RLY |  |
| 10   | CH5 N.R. RLY |  |

| CN39 |              |  |
|------|--------------|--|
| 1    | CH4 N.R. RLY |  |
| 2    | CH4 N.R. RLY |  |
| 3    | CH3 N.R. RLY |  |
| 4    | CH3 N.R. RLY |  |
| 5    | CH2 N.R. RLY |  |
| 6    | CH2 N.R. RLY |  |
| 7    | CH1 N.R. RLY |  |
| 8    | CH1 N.R. RLY |  |

| CN44 |           |    |
|------|-----------|----|
| 2    | M. CLOCK  | 1  |
| 3    | BIAS CONT | 3  |
| 4    | HX PRO    | 5  |
| 5    | SPD H/L   | 5  |
| 6    | DLY SV B  | 7  |
| 7    | R. OFF    | 7  |
| 8    | R. ON     | 9  |
| 9    | C. CLOCK  | 11 |
| 10   | V. CLOCK  | 13 |
| 11   | LED CLOCK | 15 |
| 12   | S. ERASE  | 17 |
| 13   | T. MUTE   | 19 |
| 14   | INPUT DOR | 21 |
| 15   | AMP DATA  | 23 |
| 16   | MONI B    | 25 |
| 17   | TEST/IN   | 27 |
| 18   | CUE ATT   | 29 |
| 19   | OUT H/L   | 31 |
| 20   | P.D.M.A   | 33 |

A

|          |              |          |
|----------|--------------|----------|
| NAME     | MOTHER A PCA | SHEET OF |
| PART NO. | PB7HV0A      | 3        |
| APPLIED  | PB-7HVA      | 12554    |



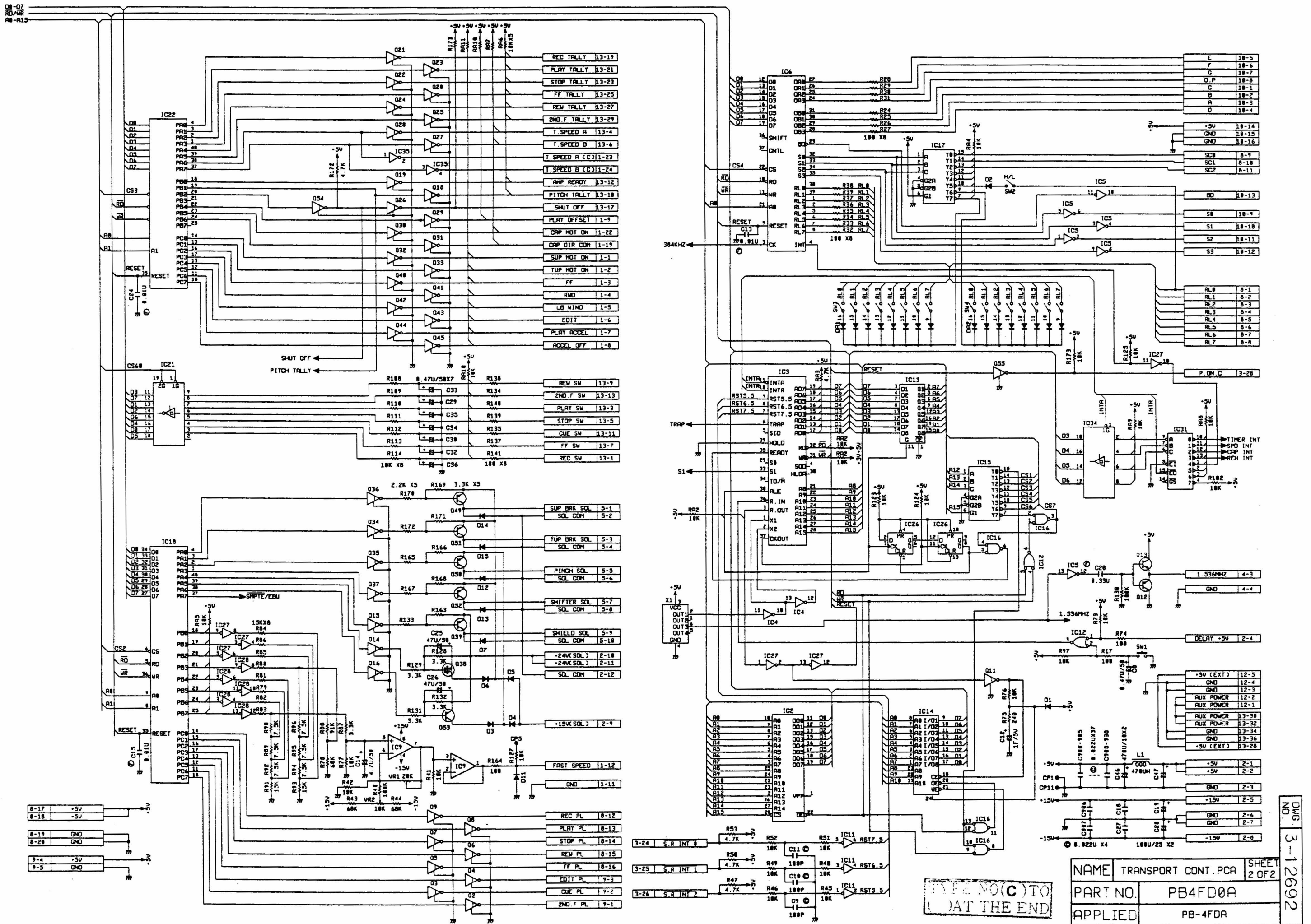



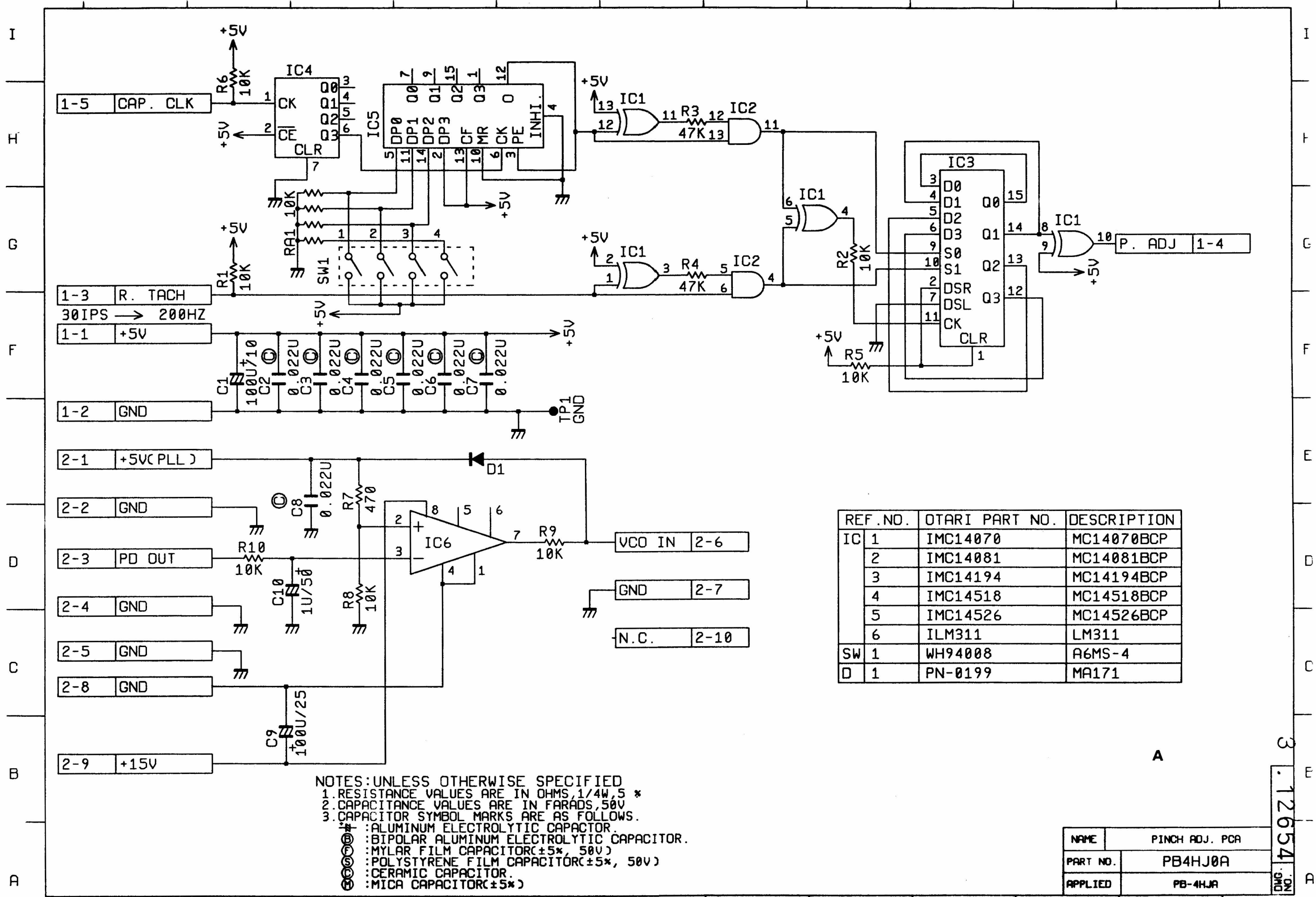

|          |                |
|----------|----------------|
| NAME     | PINCH ADJ. PCA |
| PART NO. | PB4HJ0A        |
| APPLIED  | PB-4HJA        |

3  
12654  
NO.

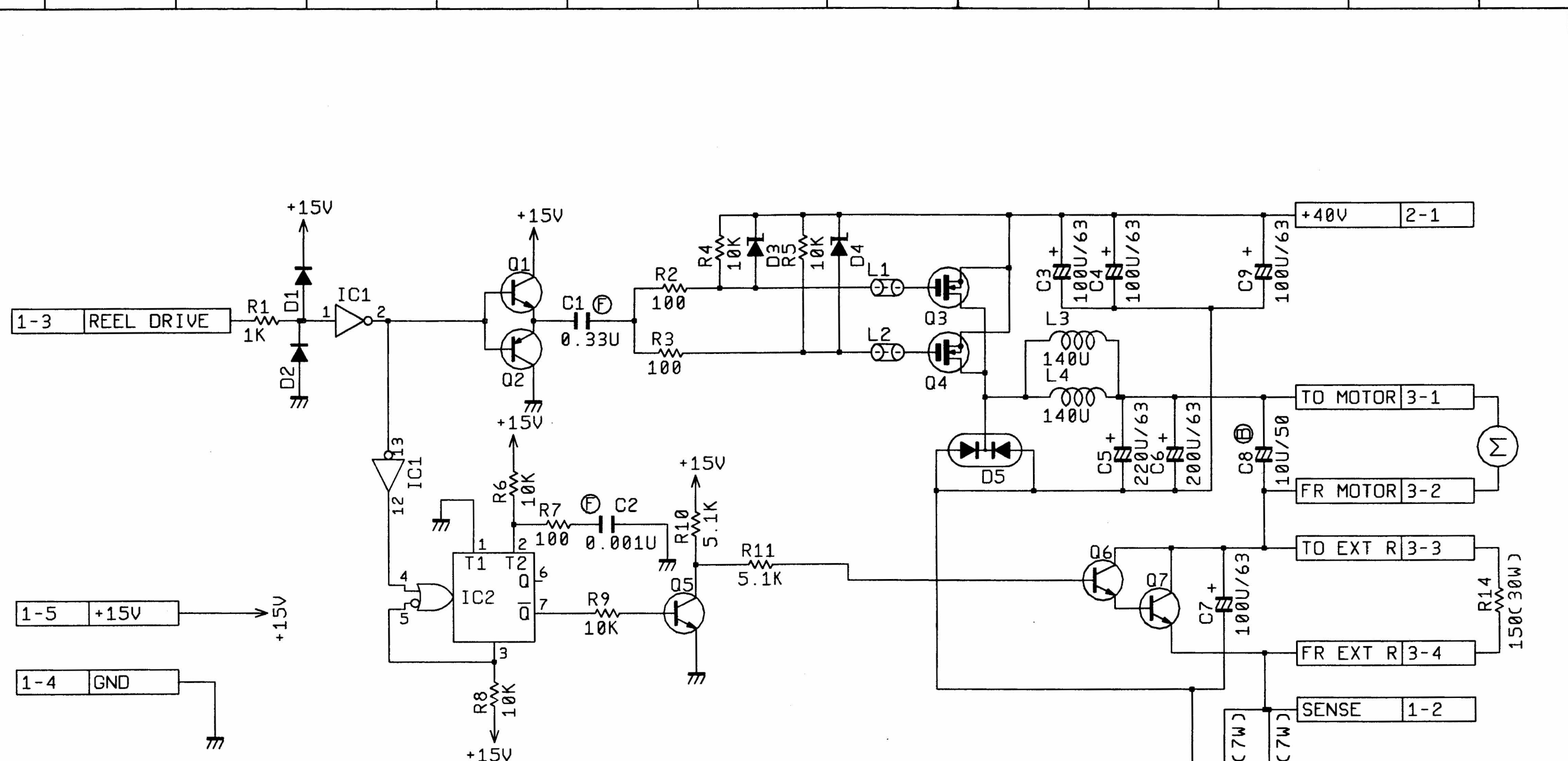

| REF. NO. | OTARI PART NO. | DESCRIPTION        |
|----------|----------------|--------------------|
| IC       | 1              | IMC14069 MC14069   |
|          | 2              | IMC14538 MC14538   |
| Q        | 1              | QC2590R 2SC2590R   |
|          | 2              | QA1110R 2SA1110R   |
|          | 3,4            | Q2SJ115Y 2SJ115Y   |
|          | 5              | QC1815BL 2SC1815BL |
|          | 6              | QC2655Y 2SC2655Y   |
|          | 7              | QC2565Y 2SC2565Y   |
|          | D              | 1,2                |
| 3,4      |                | PN1Z18 1Z18        |
| 5        |                | PNMA650 MA650      |
| L        | 1,2            | PZ4Z003 B-20L-48B  |
|          | 3,4            | IN19080 HP-054S    |

NOTES: UNLESS OTHERWISE SPECIFIED  
 1. RESISTANCE VALUES ARE IN OHMS, 1/4W, 5%.  
 2. CAPACITANCE VALUES ARE IN FARADS, 50V.  
 3. CAPACITOR SYMBOL MARKS ARE AS FOLLOWS.  
 # : ALUMINUM ELECTROLYTIC CAPACITOR.  
 @ : BIPOLAR ALUMINUM ELECTROLYTIC CAPACITOR.  
 F : MYLAR FILM CAPACITOR(±5%, 50V)  
 S : POLYSTYRENE FILM CAPACITOR(±5%, 50V)  
 C : CERAMIC CAPACITOR.  
 M : MICA CAPACITOR(±5%)

|          |                |
|----------|----------------|
| NAME     | REEL DRIVE PCB |
| PART NO. | PB4FC0A        |
| APPLIED  | PB-4FCA        |

3.12617



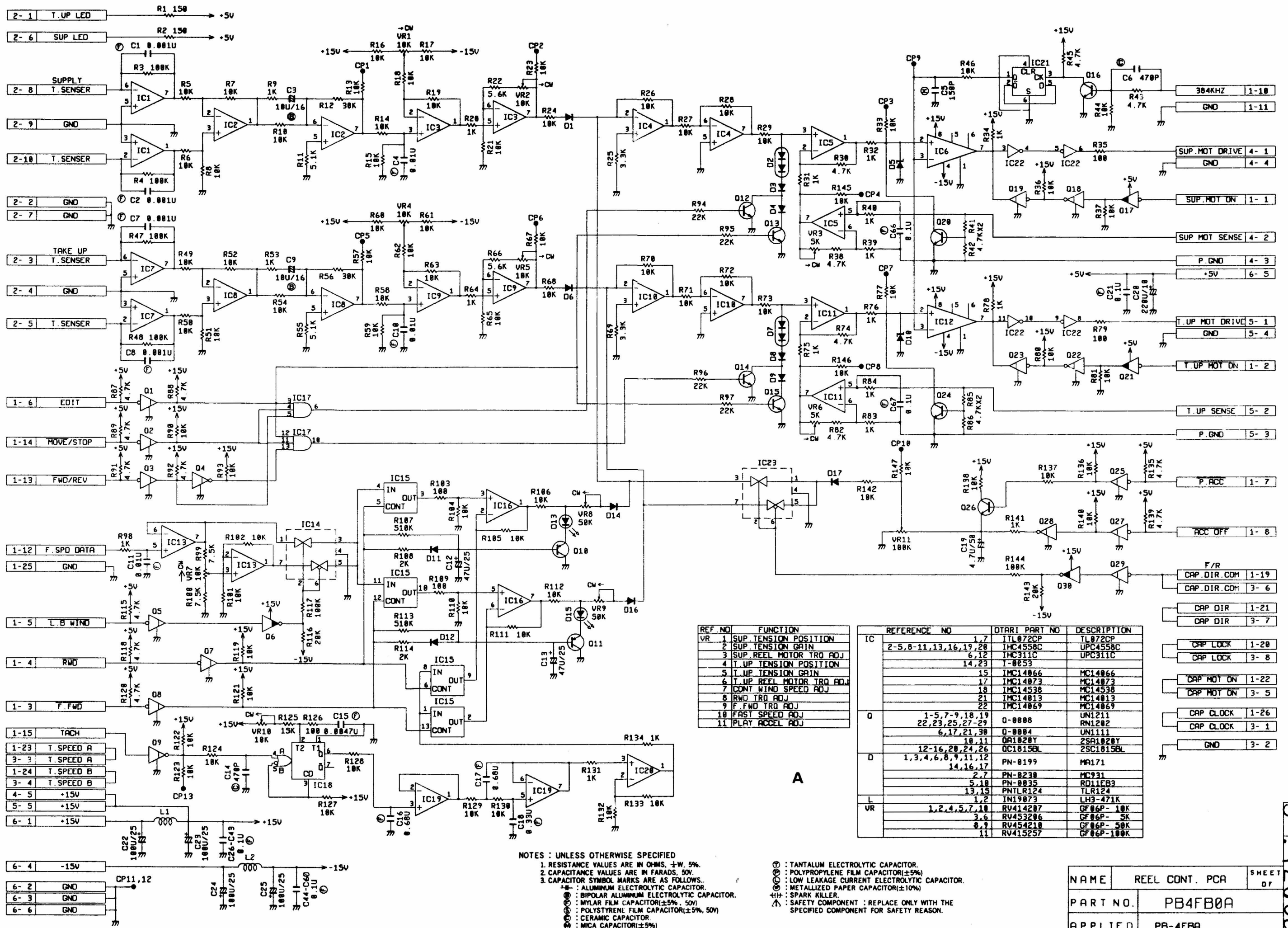

| REF. NO | FUNCTION                 |
|---------|--------------------------|
| VR 1    | SUP. TENSION POSITION    |
| 2       | SUP. TENSION GAIN        |
| 3       | SUP. REEL MOTOR TRQ ADJ  |
| 4       | T. UP TENSION POSITION   |
| 5       | T. UP TENSION GAIN       |
| 6       | T. UP REEL MOTOR TRQ ADJ |
| 7       | CONT WIND SPEED ADJ      |
| 8       | RWD TRQ ADJ              |
| 9       | F. FWD TRQ ADJ           |
| 10      | FAST SPEED ADJ           |
| 11      | PLAY ACCEL ADJ           |

| REFERENCE NO                   | OTARI PART NO | DESCRIPTION |
|--------------------------------|---------------|-------------|
| IC 1,7                         | TL072CP       | TL072CP     |
| 2-5,8-11,13,16,19,20           | IMC4558C      | UPC4558C    |
| 6,12                           | IMC311C       | UPC311C     |
| 14,23                          | T-0053        |             |
| 15                             | IMC14066      | MC14066     |
| 17                             | IMC14073      | MC14073     |
| 18                             | IMC14538      | MC14538     |
| 21                             | IMC14013      | MC14013     |
| 22                             | IMC14069      | MC14069     |
| 0 1-5,7-9,18,19,22,23,25,27-29 | 0-0008        | UN1211      |
| 6,17,21,30                     | 0-0004        | RN1202      |
| 10,11                          | QRI020Y       | UN1111      |
| 12-16,20,24,26                 | OC1015BL      | 2SA1020Y    |
| 1,3,4,6,8,9,11,12,14,16,17     | PN-0199       | 2SC1015BL   |
| 2,7                            | PN-0230       | MA171       |
| 5,10                           | PN-0035       | MC931       |
| 13,15                          | PNLR124       | RD11EB3     |
| 1,2                            | IN19073       | TLR124      |
| 1,2                            | IN19073       | LH3-471K    |
| 1,2,4,5,7,10                   | RV414207      |             |
| 3,6                            | RV453206      | GF06P-10K   |
| 8,9                            | RV454210      | GF06P-50K   |
| 11                             | RV415257      | GF06P-100K  |

NOTES : UNLESS OTHERWISE SPECIFIED  
 1. RESISTANCE VALUES ARE IN OHMS, ± 5%  
 2. CAPACITANCE VALUES ARE IN FARADS, 50V.  
 3. CAPACITOR SYMBOL MARKS ARE AS FOLLOWS:  
 ⊕ : ALUMINUM ELECTROLYTIC CAPACITOR.  
 ⊖ : BIPOLAR ALUMINUM ELECTROLYTIC CAPACITOR.  
 ⊕ : MYLAR FILM CAPACITOR(±5%, 50V)  
 ⊖ : POLYSTYRENE FILM CAPACITOR(±5%, 50V)  
 ⊕ : CERAMIC CAPACITOR.  
 ⊖ : MICA CAPACITOR(±5%)

⊕ : TANTALUM ELECTROLYTIC CAPACITOR.  
 ⊖ : POLYPROPYLENE FILM CAPACITOR(±5%)  
 ⊕ : LOW LEAKAGE CURRENT ELECTROLYTIC CAPACITOR.  
 ⊖ : METALLIZED PAPER CAPACITOR(±10%)  
 ⊕ : SPARK KILLER.  
 ⊖ : SAFETY COMPONENT : REPLACE ONLY WITH THE SPECIFIED COMPONENT FOR SAFETY REASON.

| NAME     | REEL CONT. PCA | SHEET OF |
|----------|----------------|----------|
| PART NO. | PB4FB0A        |          |
| APPLIED  | PB-4FBA        |          |

3. 12608



R  
B  
C  
D  
F  
G  
H  
I

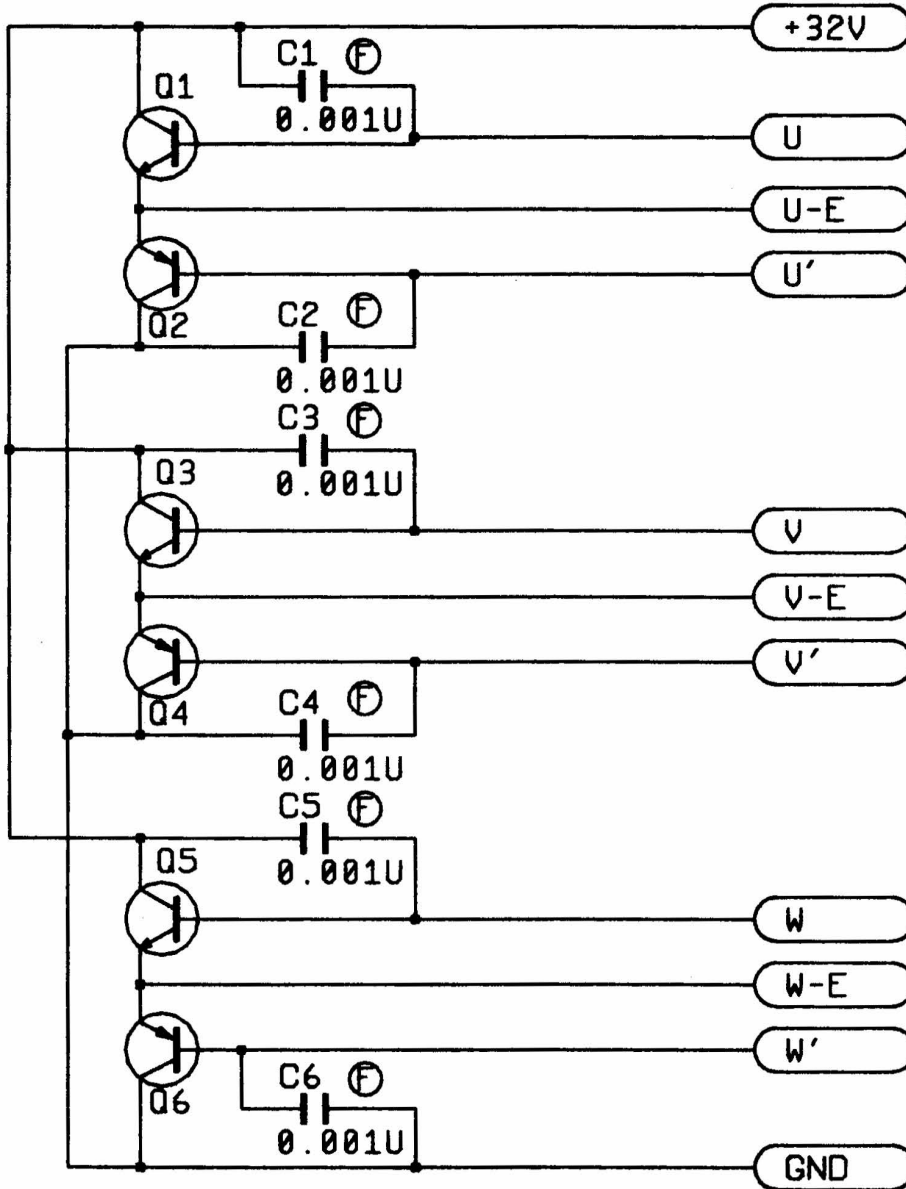

| REF. NO.  | OTARI PART NO. | DESCRIPTION |
|-----------|----------------|-------------|
| Q 1, 3, 5 | QD1436K        | 2SD1436K    |
| 2, 4, 6   | QB1032K        | 2SB1032K    |

|          |                |
|----------|----------------|
| NAME     | CAP DRIVE ASSY |
| PART NO. | ZA93G0A        |
| APPLIED  | ZA-93GA        |

4  
42937  
DWG. NO.

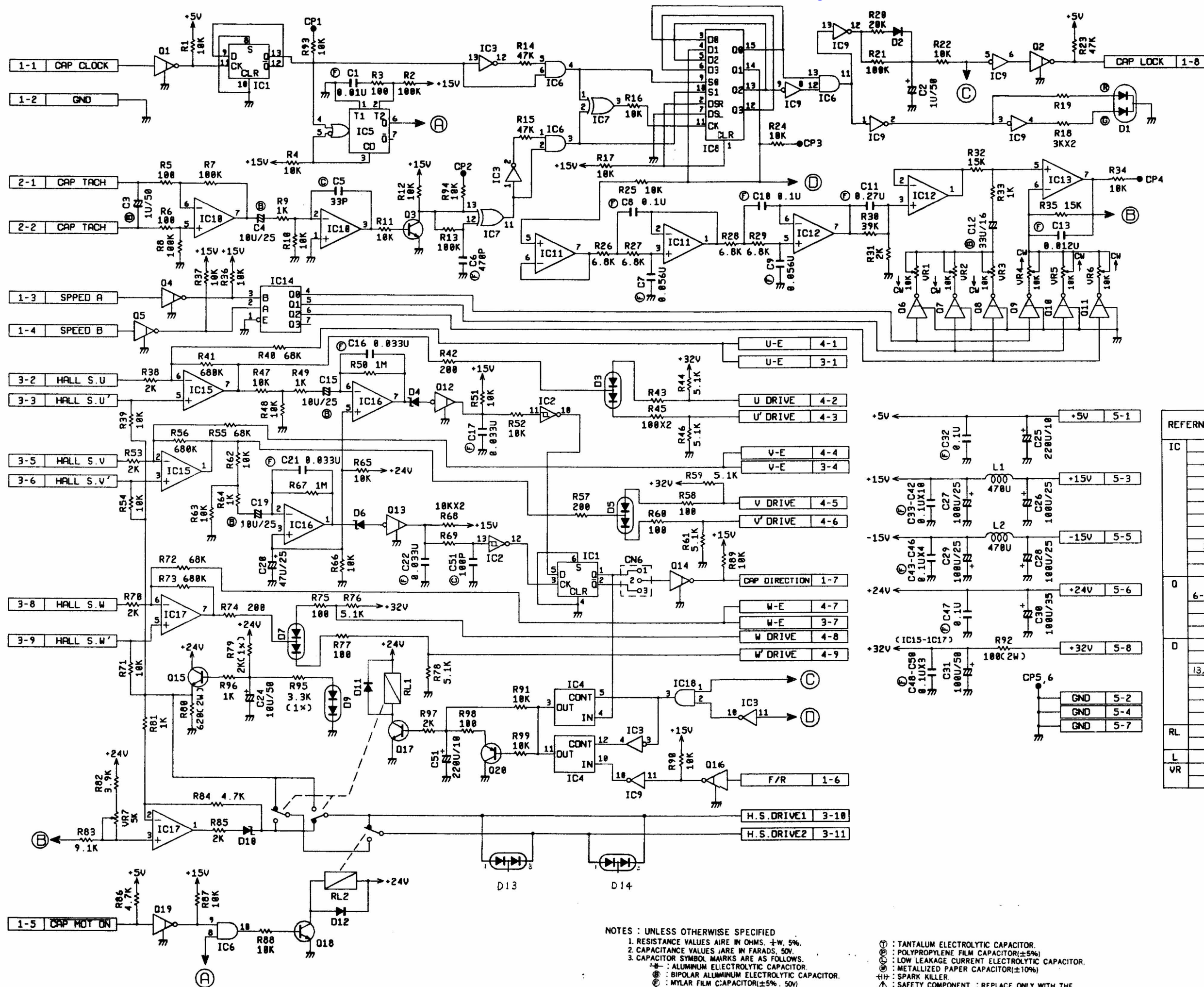

- NOTES : UNLESS OTHERWISE SPECIFIED
1. RESISTANCE VALUES ARE IN OHMS. ±W. 5%.
  2. CAPACITANCE VALUES ARE IN FARADS. 50V.
  3. CAPACITOR SYMBOL MARKS ARE AS FOLLOWS.
- ⊕ : TANTALUM ELECTROLYTIC CAPACITOR.
  - ⊖ : POLYPROPYLENE FILM CAPACITOR(±5%)
  - ⊙ : LOW LEAKAGE CURRENT ELECTROLYTIC CAPACITOR.
  - ⊗ : ALUMINUM ELECTROLYTIC CAPACITOR.
  - ⊘ : BIPOLAR ALUMINUM ELECTROLYTIC CAPACITOR.
  - ⊙ : MYLAR FILM CAPACITOR(±5% . 50V)
  - ⊙ : POLYSTYRENE FILM CAPACITOR(±5% . 50V)
  - ⊙ : CERAMIC CAPACITOR.
  - ⊙ : MICA CAPACITOR(±5%)
  - ⊕ : SPARK KILLER.
  - ⊕ : SAFETY COMPONENT : REPLACE ONLY WITH THE SPECIFIED COMPONENT FOR SAFETY REASON.

| REFERENCE NO. | OTARI PART NO. | DESCRIPTION           |                       |
|---------------|----------------|-----------------------|-----------------------|
| IC            | 1              | IMC14813 MC14813      |                       |
|               | 2              | IMC14584 MC14584      |                       |
|               | 3,9            | IMC14869 MC14869      |                       |
|               | 4              | IMC14866 MC14866      |                       |
|               | 5              | IMC14538 MC14538      |                       |
|               | 6,18           | IMC14881 MC14881      |                       |
|               | 7              | IMC14870 MC14870      |                       |
|               | 8              | IMC14194 MC14194      |                       |
|               | 10,15-17       | I-8067 MS219P         |                       |
|               | 11-13          | IHC4558C UPC4558C     |                       |
|               | 14             | IMC14555 MC14555      |                       |
|               | Q              | 1,2,4,5,6-14,16,19    | Q-8088 UN1211, RN1282 |
|               |                | 3                     | QC2878 2SC2878        |
|               |                | 15,17,18              | QC2655Y 2SC2655Y      |
| 20            |                | QA1015GR 2SA1015GR    |                       |
| D             |                | 1                     | PNSLP520 SLP-520      |
|               |                | 2                     | PN-0199 MA171         |
|               |                | 13,14,3,5,7           | PN-0238 MC931         |
|               |                | 4,6                   | PN-0038 RD12EB3       |
|               | 9              | PNVD1222 VD1222       |                       |
|               | 10             | PN-0026 RD8-2EB3      |                       |
| RL            | 1              | RY2DC890 G6A-274P/24V |                       |
|               | 2              | RY1DC851 G20-1014B    |                       |
| L             | 1,2            | IN19073 LH3-471K      |                       |
|               | 1-6            | RV414312 3296W-1-103  |                       |
| VR            | 1-6            | RV414312 3296W-1-103  |                       |
|               | 7              | RV453206 GF06P-5K     |                       |

| NAME     | CAP. COND. PCA | SHEET OF |
|----------|----------------|----------|
| PART NO. | PB4FA0A        |          |
| APPLIED  | PB-4FAA        |          |

A

3-12607





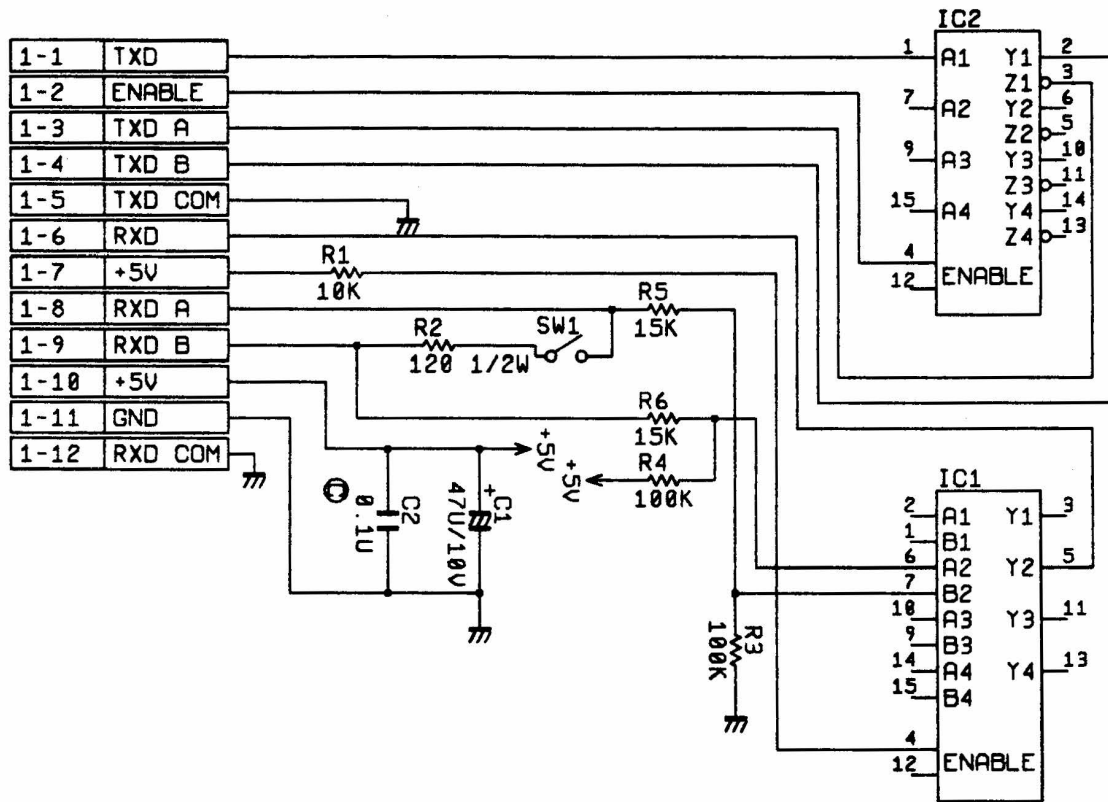

| REF. NO. | OTARI PART NO. | DESCRIPTION         |
|----------|----------------|---------------------|
| IC       | 1              | IG175N SN75175N     |
|          | 2              | IG174N SN75174N     |
| SW       | 1              | WH31056 SSS1X2NB2X2 |
|          |                |                     |
|          |                |                     |
|          |                |                     |
|          |                |                     |

NOTES: UNLESS OTHERWISE SPECIFIED  
 1. RESISTANCE VALUES ARE IN OHMS, 1/4W, 5%  
 2. CAPACITANCE VALUES ARE IN FARADS, 50V  
 3. CAPACITOR SYMBOL MARKS ARE AS FOLLOWS.  
 ⊕ : ALUMINUM ELECTROLYTIC CAPACITOR.  
 ⊖ : BIPOLAR ALUMINUM ELECTROLYTIC CAPACITOR.  
 ○ : MYLAR FILM CAPACITOR (±5%, 50V)  
 ⊙ : POLYSTYRENE FILM CAPACITOR (±5%, 50V)  
 ⊗ : CERAMIC CAPACITOR.  
 ⊕ : MICA CAPACITOR (±5%)

|          |                 |                 |
|----------|-----------------|-----------------|
| NAME     | 422 DRV/RCV PCA | SHEET<br>1 OF 1 |
| PART NO. | PB4EZ0A         |                 |
| APPLIED  | PB-4EZA         |                 |

4 . 42796  
 DWG.  
 NO.



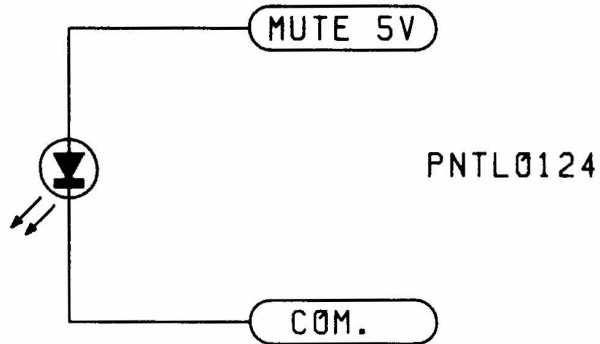

MUTE 5V FROM

|          |          |
|----------|----------|
| CH1 (9 ) | CN77-1-1 |
| CH2 (10) | CN77-2-1 |
| CH3 (11) | CN77-3-1 |
| CH4 (12) | CN77-4-1 |
| CH5 (13) | CN77-5-1 |
| CH6 (14) | CN77-6-1 |
| CH7 (15) | CN77-7-1 |
| CH8 (16) | CN77-8-1 |

COM. FROM

|          |          |
|----------|----------|
| CH1 (9 ) | CN77-1-2 |
| CH2 (10) | CN77-2-2 |
| CH3 (11) | CN77-3-2 |
| CH4 (12) | CN77-4-2 |
| CH5 (13) | CN77-5-2 |
| CH6 (14) | CN77-6-2 |
| CH7 (15) | CN77-7-2 |
| CH8 (16) | CN77-8-2 |

A

|          |                                  |                       |
|----------|----------------------------------|-----------------------|
|          |                                  | Dwg.<br>NO. 4 . 36987 |
| NAME     | RECORD INDICATOR<br>P.C.B. ASS'Y |                       |
| PART NO. | PB7A0A                           |                       |
| APPLIED  | PB-7AAA                          |                       |

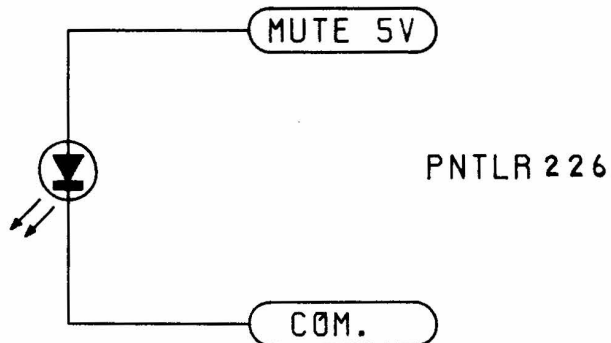

MUTE 5V FROM

|          |          |
|----------|----------|
| CH1 (9 ) | CN78-1-1 |
| CH2 (10) | CN78-2-1 |
| CH3 (11) | CN78-3-1 |
| CH4 (12) | CN78-4-1 |
| CH5 (13) | CN78-5-1 |
| CH6 (14) | CN78-6-1 |
| CH7 (15) | CN78-7-1 |
| CH8 (16) | CN78-8-1 |

COM. FROM

|          |          |
|----------|----------|
| CH1 (9 ) | CN78-1-2 |
| CH2 (10) | CN78-2-2 |
| CH3 (11) | CN78-3-2 |
| CH4 (12) | CN78-4-2 |
| CH5 (13) | CN78-5-2 |
| CH6 (14) | CN78-6-2 |
| CH7 (15) | CN78-7-2 |
| CH8 (16) | CN78-8-2 |

A

|          |                                |
|----------|--------------------------------|
| NAME     | PEAK INDICATOR<br>P.C.B. ASS'Y |
| PART NO. | PB7AB0A                        |
| APPLIED  | PB-7ABA                        |

Dwg. No. 4 . 36989

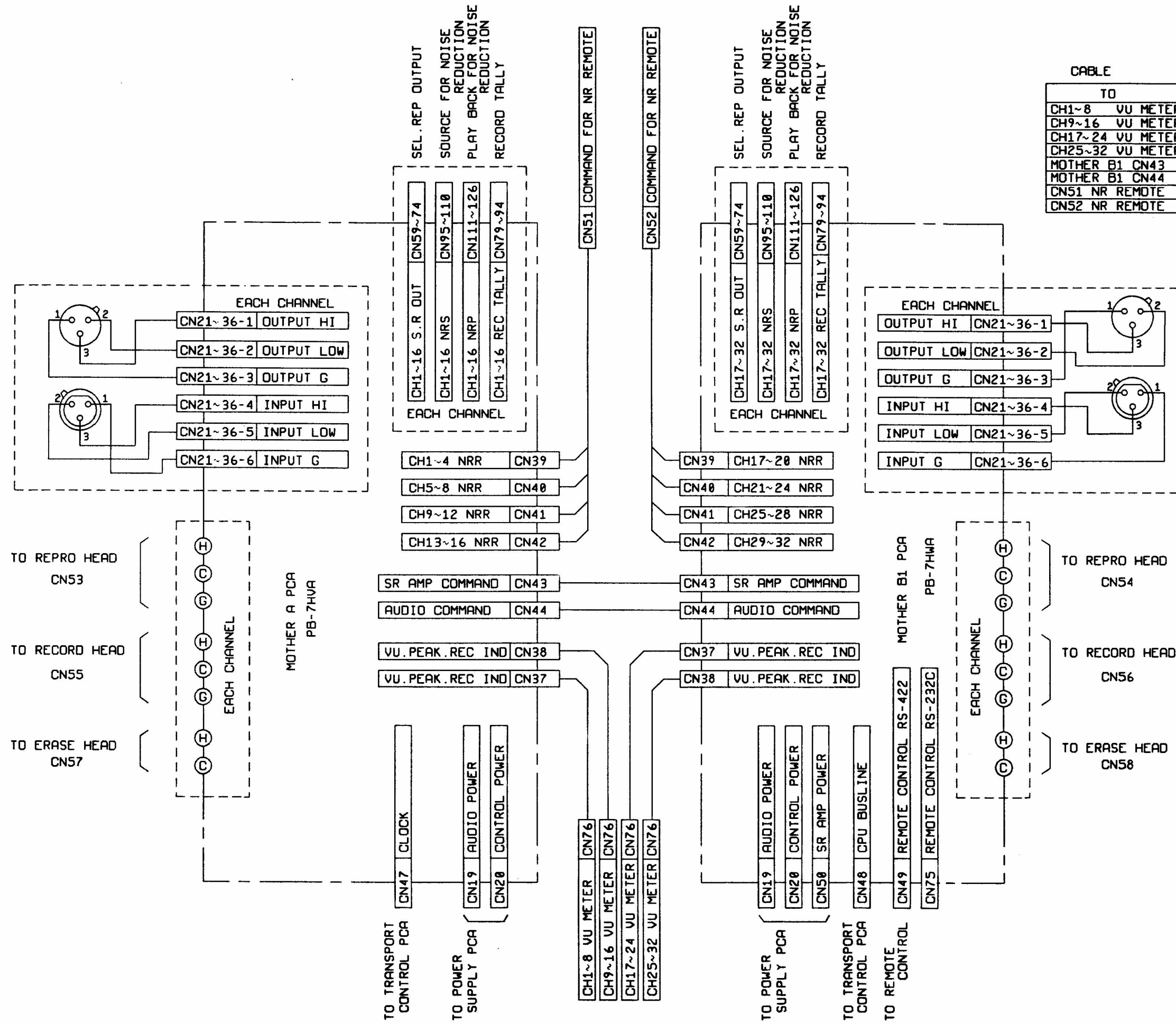

CABLE

| TO               | FROM              | DESCRIPTION |
|------------------|-------------------|-------------|
| CH1~8 VU METER   | MOTHER A CN37     | PZ9D137     |
| CH9~16 VU METER  | MOTHER A CN38     | PZ9D137     |
| CH17~24 VU METER | MOTHER B1 CN37    | PZ9D138     |
| CH25~32 VU METER | MOTHER B1 CN38    | PZ9D138     |
| MOTHER B1 CN43   | MOTHER A CN43     | PZ9D139     |
| MOTHER B1 CN44   | MOTHER A CN43     | PZ9D139     |
| CN51 NR REMOTE   | MOTHER A CN39~42  | ZA-6EF      |
| CN52 NR REMOTE   | MOTHER B1 CN39~42 | ZA-6EF      |

CN NUMBER OF EACH CHANNEL

| CH | CONNECTOR NUMBER |    |    |     |     |
|----|------------------|----|----|-----|-----|
|    | 21               | 59 | 79 | 95  | 111 |
| 1  | 21               | 59 | 79 | 95  | 111 |
| 2  | 22               | 60 | 80 | 96  | 112 |
| 3  | 23               | 61 | 81 | 97  | 113 |
| 4  | 24               | 62 | 82 | 98  | 114 |
| 5  | 25               | 63 | 83 | 99  | 115 |
| 6  | 26               | 64 | 84 | 100 | 116 |
| 7  | 27               | 65 | 85 | 101 | 117 |
| 8  | 28               | 66 | 86 | 102 | 118 |
| 9  | 29               | 67 | 87 | 103 | 119 |
| 10 | 30               | 68 | 88 | 104 | 120 |
| 11 | 31               | 69 | 89 | 105 | 121 |
| 12 | 32               | 70 | 90 | 106 | 122 |
| 13 | 33               | 71 | 91 | 107 | 123 |
| 14 | 34               | 72 | 92 | 108 | 124 |
| 15 | 35               | 73 | 93 | 109 | 125 |
| 16 | 36               | 74 | 94 | 110 | 126 |
| 17 | 21               | 59 | 79 | 95  | 111 |
| 18 | 22               | 60 | 80 | 96  | 112 |
| 19 | 23               | 61 | 81 | 97  | 113 |
| 20 | 24               | 62 | 82 | 98  | 114 |
| 21 | 25               | 63 | 83 | 99  | 115 |
| 22 | 26               | 64 | 84 | 100 | 116 |
| 23 | 27               | 65 | 85 | 101 | 117 |
| 24 | 28               | 66 | 86 | 102 | 118 |
| 25 | 29               | 67 | 87 | 103 | 119 |
| 26 | 30               | 68 | 88 | 104 | 120 |
| 27 | 31               | 69 | 89 | 105 | 121 |
| 28 | 32               | 70 | 90 | 106 | 122 |
| 29 | 33               | 71 | 91 | 107 | 123 |
| 30 | 34               | 72 | 92 | 108 | 124 |
| 31 | 35               | 73 | 93 | 109 | 125 |
| 32 | 36               | 74 | 94 | 110 | 126 |

|          |                             |          |
|----------|-----------------------------|----------|
| NAME     | AUDIO WIRING DIAGRAM (32CH) | SHEET OF |
| PART NO. | A11100B                     |          |
| APPLIED  |                             |          |

3.12545



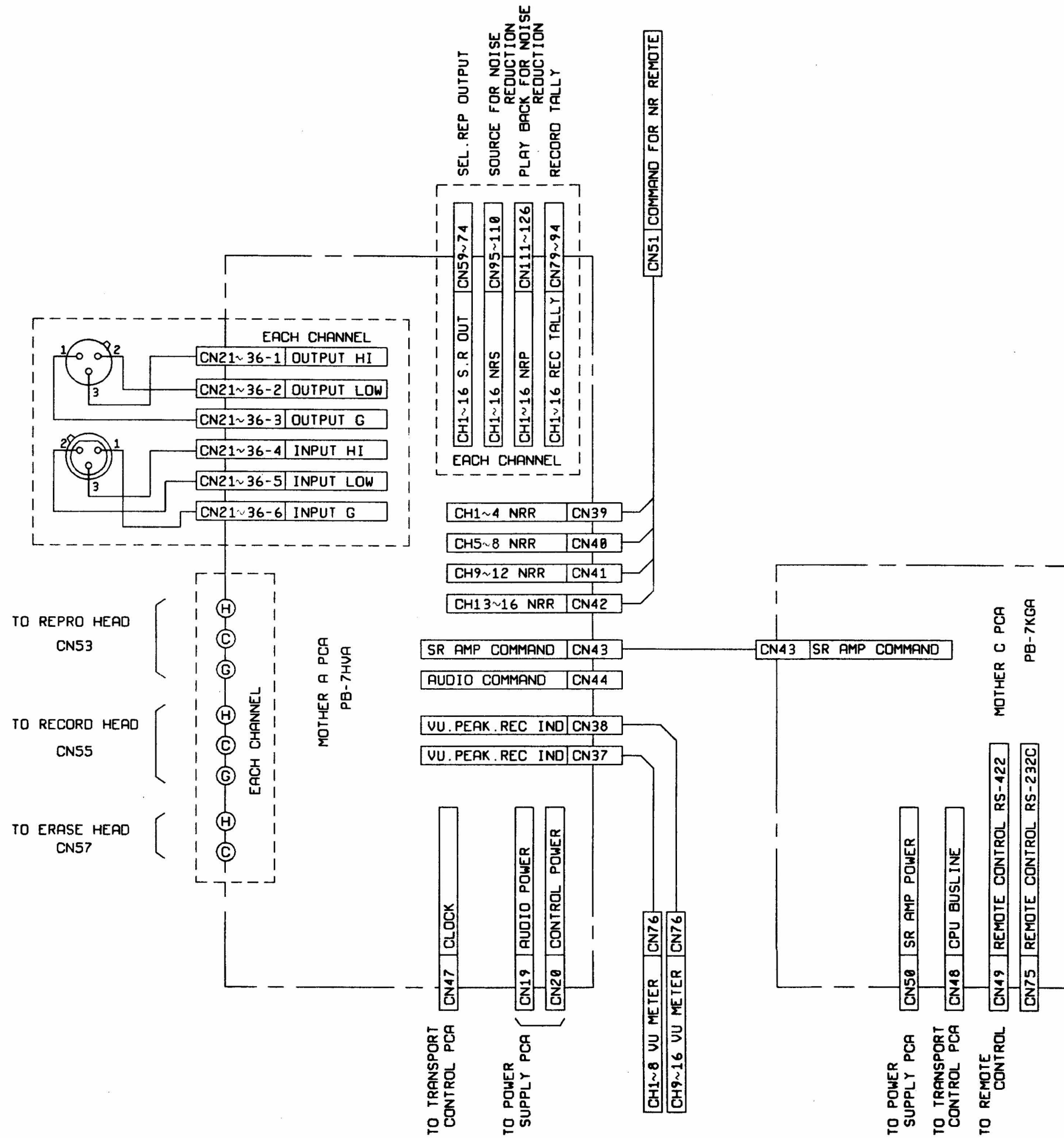

CABLE

| TO              | FROM             | DESCRIPTION |
|-----------------|------------------|-------------|
| CH1~8 VU METER  | MOTHER A CN37    | PZ9D137     |
| CH9~16 VU METER | MOTHER A CN38    | PZ9D137     |
| MOTHER C CN43   | MOTHER A CN43    | PZ9D139     |
| CN51 NR REMOTE  | MOTHER A CN39~42 | ZA-6EF      |

CN NUMBER OF EACH CHANNEL

| CH | CONNECTOR NUMBER |    |    |     |     |     |
|----|------------------|----|----|-----|-----|-----|
|    | 21               | 59 | 79 | 95  | 111 | 111 |
| 1  | 21               | 59 | 79 | 95  | 111 | 111 |
| 2  | 22               | 60 | 80 | 96  | 112 | 112 |
| 3  | 23               | 61 | 81 | 97  | 113 | 113 |
| 4  | 24               | 62 | 82 | 98  | 114 | 114 |
| 5  | 25               | 63 | 83 | 99  | 115 | 115 |
| 6  | 26               | 64 | 84 | 100 | 116 | 116 |
| 7  | 27               | 65 | 85 | 101 | 117 | 117 |
| 8  | 28               | 66 | 86 | 102 | 118 | 118 |
| 9  | 29               | 67 | 87 | 103 | 119 | 119 |
| 10 | 30               | 68 | 88 | 104 | 120 | 120 |
| 11 | 31               | 69 | 89 | 105 | 121 | 121 |
| 12 | 32               | 70 | 90 | 106 | 122 | 122 |
| 13 | 33               | 71 | 91 | 107 | 123 | 123 |
| 14 | 34               | 72 | 92 | 108 | 124 | 124 |
| 15 | 35               | 73 | 93 | 109 | 125 | 125 |
| 16 | 36               | 74 | 94 | 110 | 126 | 126 |

|          |                             |          |
|----------|-----------------------------|----------|
| NAME     | AUDIO WIRING DIAGRAM (16CH) | SHEET OF |
| PART NO. | A11220B                     |          |
| APPLIED  |                             |          |

3.12547



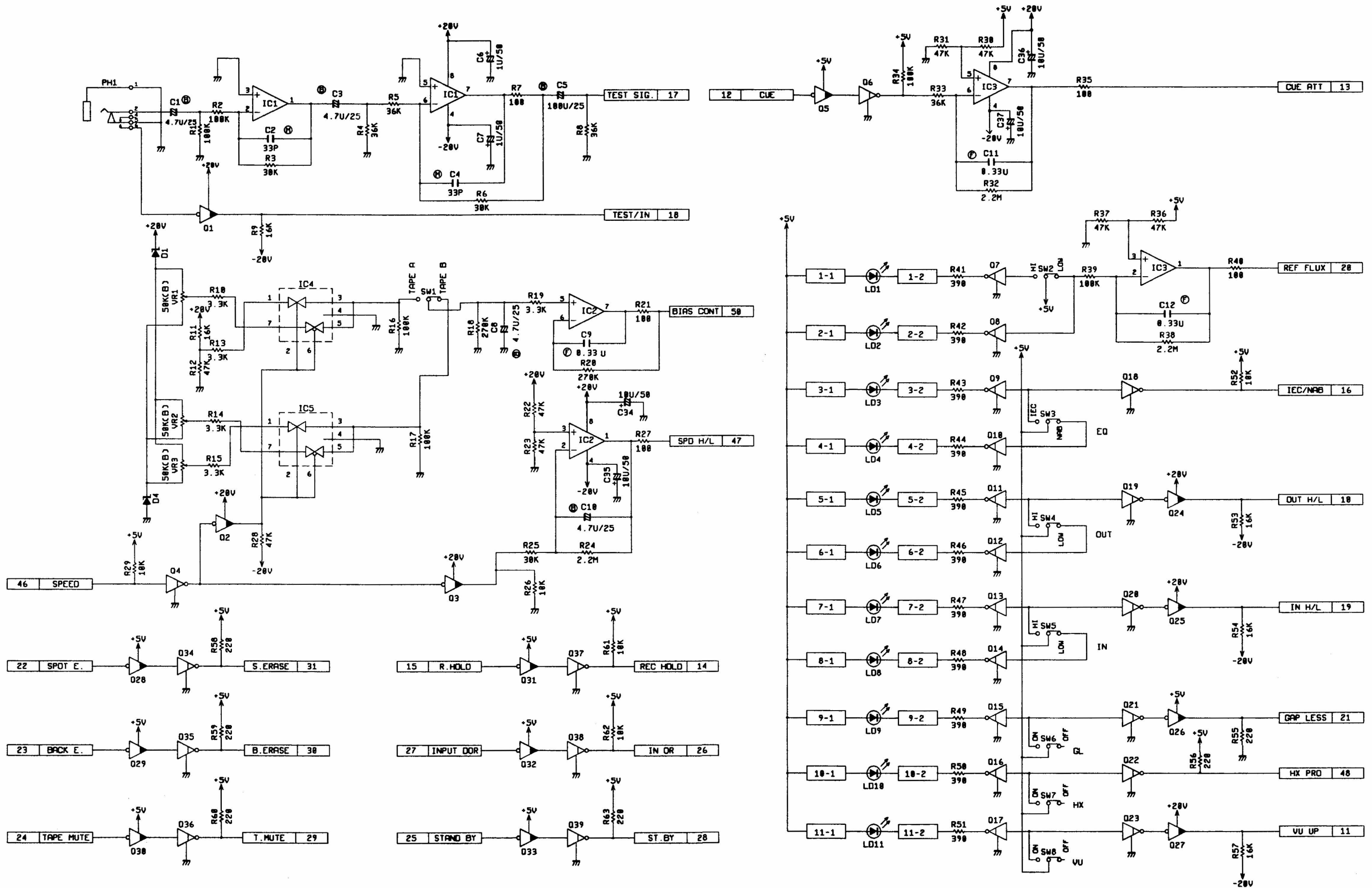

NOTES : UNLESS OTHERWISE SPECIFIED

1. RESISTANCE VALUES ARE IN OHMS, ±W. 5%.
  2. CAPACITANCE VALUES ARE IN FARADS, 50V.
  3. CAPACITOR SYMBOL MARKS ARE AS FOLLOWS.
- ⊖ : ALUMINUM ELECTROLYTIC CAPACITOR.
  - ⊕ : BIPOLAR ALUMINUM ELECTROLYTIC CAPACITOR.
  - ⊙ : MYLAR FILM CAPACITOR(±5%, 50V)
  - ⊚ : POLYSTYRENE FILM CAPACITOR(±5%, 50V)
  - ⊛ : CERAMIC CAPACITOR.
  - ⊜ : MICA CAPACITOR(±5%)

- Ⓣ : TANTALUM ELECTROLYTIC CAPACITOR.
- Ⓢ : POLYPROPYLENE FILM CAPACITOR(±5%)
- Ⓡ : LOW LEAKAGE CURRENT ELECTROLYTIC CAPACITOR.
- Ⓜ : METALLIZED PAPER CAPACITOR(±10%)
- Ⓚ : SPARK KILLER.
- Ⓛ : SAFETY COMPONENT : REPLACE ONLY WITH THE SPECIFIED COMPONENT FOR SAFETY REASON.

A

|          |                              |                 |
|----------|------------------------------|-----------------|
| NAME     | AUDIO CONT. PCA<br>(COMMAND) | SHEET<br>1 OF 2 |
| PART NO. | PB4FF0A                      |                 |
| APPLIED  | PB-4FFA                      |                 |

3.12548

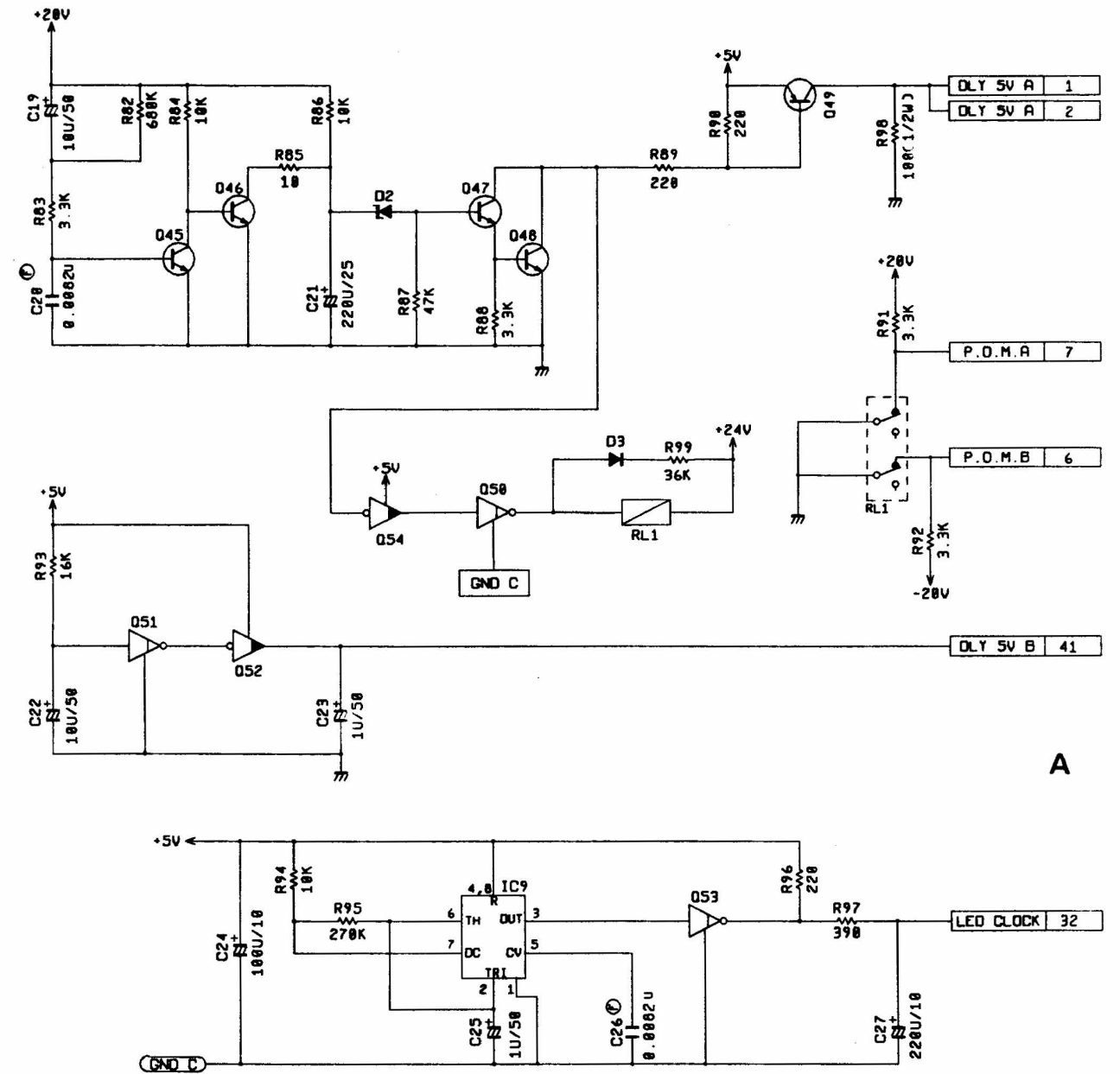
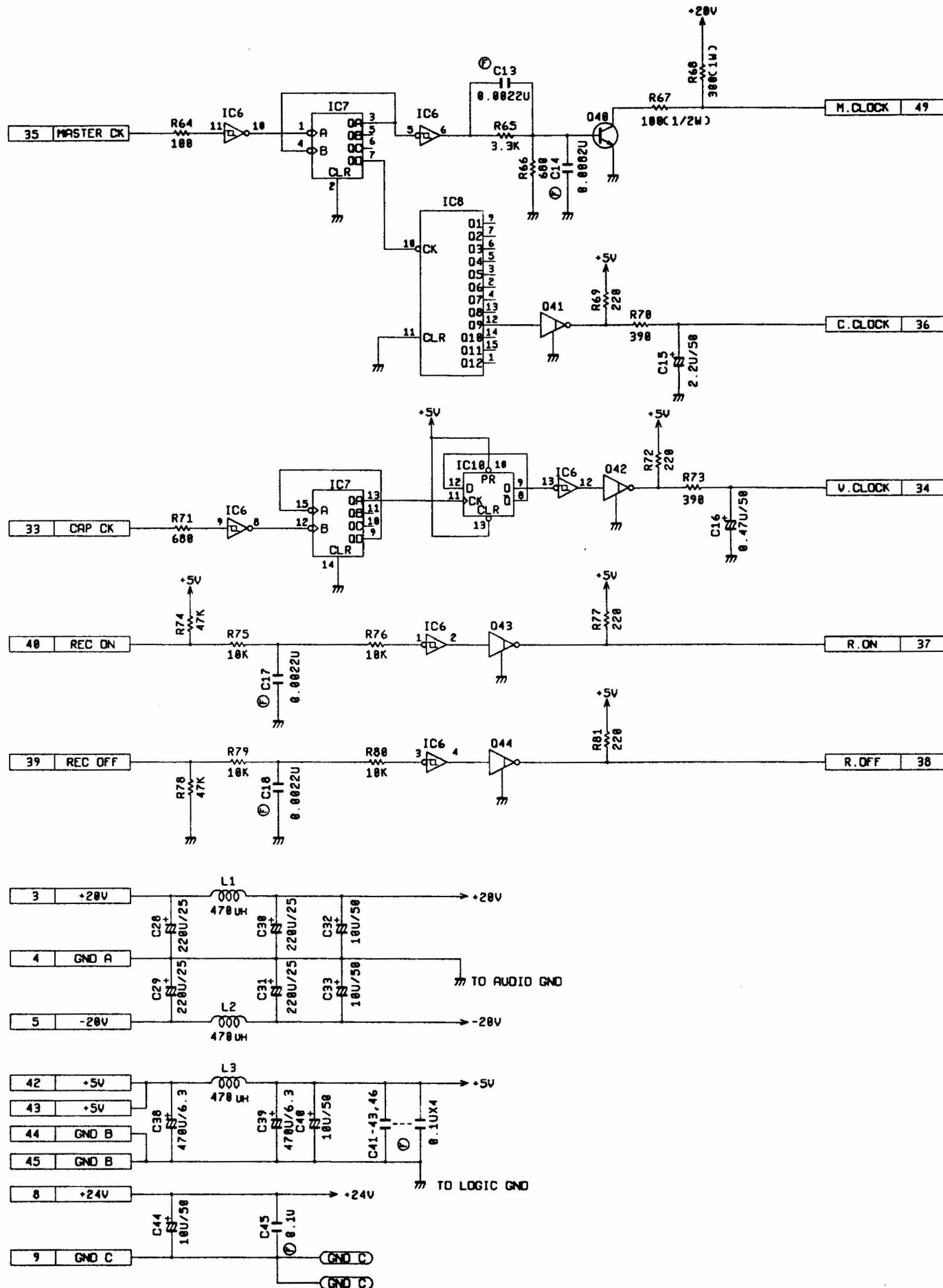

| REFERENCE NO. | OTARI PART NO. | DESCRIPTION                   |
|---------------|----------------|-------------------------------|
| IC            | 1-3            | I-8847 OR MS219P OR NLM45480X |
|               | 4,5            | I-8853 FET SW NP              |
|               | 6              | IQ14 TC74HC14P                |
|               | 7              | IQ39 TC74HC39P                |
|               | 8              | IQ48 TC74HC48P                |
|               | 9              | I-NE555V NE555V               |
|               | 10             | IQ74 TC74HC74P                |
| O             | 1-3,5          | 0-8884 UN1111 OR UN4111       |
|               | 24-33,52,54    | 0-8884 UN1211 OR UN4211       |
|               | 4,6-23,34-39   | 0-8888                        |
|               | 41-44,58,51,53 | 0-8888                        |
|               | 48,45-48       | QC1815RL 2SC1815RL            |
|               | 49             | Q51828Y 2SA1828Y              |
| D             | 1              | PN-8811 RDS-1CB3              |
|               | 2              | PN-8844 R013CB3               |
|               | 3              | PN-8257 SP1-XNO2              |
|               | 4              | PN-8832 R018CB3               |
| L             | 1-3            | IN19876 LHL-471K              |

| REF. NO. | OTARI PART NO. | DESCRIPTION   |
|----------|----------------|---|
| UR       | 1              | RV454174 EVMIC0801B54 MASTER BIAS LVL TAPE A HI SPD               |
|          | 2              | RV454174 EVMIC0801B54 MASTER BIAS SELECT TAPE B HI SPD            |
|          | 3              | RV454174 EVMIC0801B54 MASTER BIAS SELECT TAPE B LOW SPD           |
| RL       | 1              | RY2DC889 GSA-1003F POWER ON MUTE RELAY                            |
| SW       | 1              | WH31832 AS10-6M MASTER BIAS SELECT TAPE A/B REFERENCE FLUX HI/LOW |
|          | 2              | WH31832 AS10-6M ED IEC/NRB  |
|          | 3              | WH31822 FA02-A OUTPUT LEVEL +4DBM / -8DBM                         |
|          | 4              | WH31822 FA02-A INPUT LEVEL +4DBM / -8DBM                          |
|          | 5              | WH31822 FA02-A GAP LESS RECORD ON/OFF                             |
|          | 6              | WH31822 FA02-A DOLBY HX PRO ON/OFF                                |
|          | 7              | WH31822 FA02-A VU +100B ON/OFF                                    |
| PH       | 1              | DN601174 HLJ0306-01-030 EXTERNAL TEST OSCILLATOR JACK             |
| LD       | 1              | PNTL0124 TL0124 REFERENCE FLUX HI                                 |
|          | 2              | PNTL0124 TL0124 REFERENCE FLUX LOW                                |
|          | 3              | PNTL0124 TL0124 ED  |
|          | 4              | PNTL0124 TL0124 IEC   |
|          | 5              | PNTL0124 TL0124 NRB   |
|          | 6              | PNTL0124 TL0124 OUTPUT LEVEL +4DBM                                |
|          | 7              | PNTL0124 TL0124 OUTPUT LEVEL -8DBM                                |
|          | 8              | PNTL0124 TL0124 INPUT LEVEL +4DBM                                 |
|          | 9              | PNTL0124 TL0124 INPUT LEVEL -8DBM                                 |
|          | 10             | PNTL0124 TL0124 GAP LESS RECORD ON                                |
|          | 11             | PNTL0124 TL0124 DOLBY HX PRO ON                                   |
|          | 12             | PNTL0124 TL0124 VU +100B ON                                       |

NOTES : UNLESS OTHERWISE SPECIFIED

- RESISTANCE VALUES ARE IN OHMS, ±W. 5%.
- CAPACITANCE VALUES ARE IN FARADS, 50V.
- CAPACITOR SYMBOL MARKS ARE AS FOLLOWS.

- ⊖ : ALUMINUM ELECTROLYTIC CAPACITOR.
- ⊕ : BIPOLAR ALUMINUM ELECTROLYTIC CAPACITOR.
- ⊙ : MYLAR FILM CAPACITOR(±5%, 50V)
- ⊚ : POLYSTYRENE FILM CAPACITOR(±5%, 50V)
- ⊛ : CERAMIC CAPACITOR.
- ⊜ : MICA CAPACITOR(±5%)

- ⊕ : TANTALUM ELECTROLYTIC CAPACITOR.
- ⊖ : POLYPROPYLENE FILM CAPACITOR(±5%)
- ⊙ : LOW LEAKAGE CURRENT ELECTROLYTIC CAPACITOR.
- ⊚ : METALLIZED PAPER CAPACITOR(±10%)
- ⊛ : SPARK KILLER.
- ⊜ : SAFETY COMPONENT : REPLACE ONLY WITH THE SPECIFIED COMPONENT FOR SAFETY REASON.

|          |                         |              |
|----------|-------------------------|--------------|
| NAME     | AUDIO CONT. PCA (CLOCK) | SHEET 2 OF 2 |
| PART NO. | PB4FF0A                 |              |
| APPLIED  | PB-4FFA                 |              |

3.12549



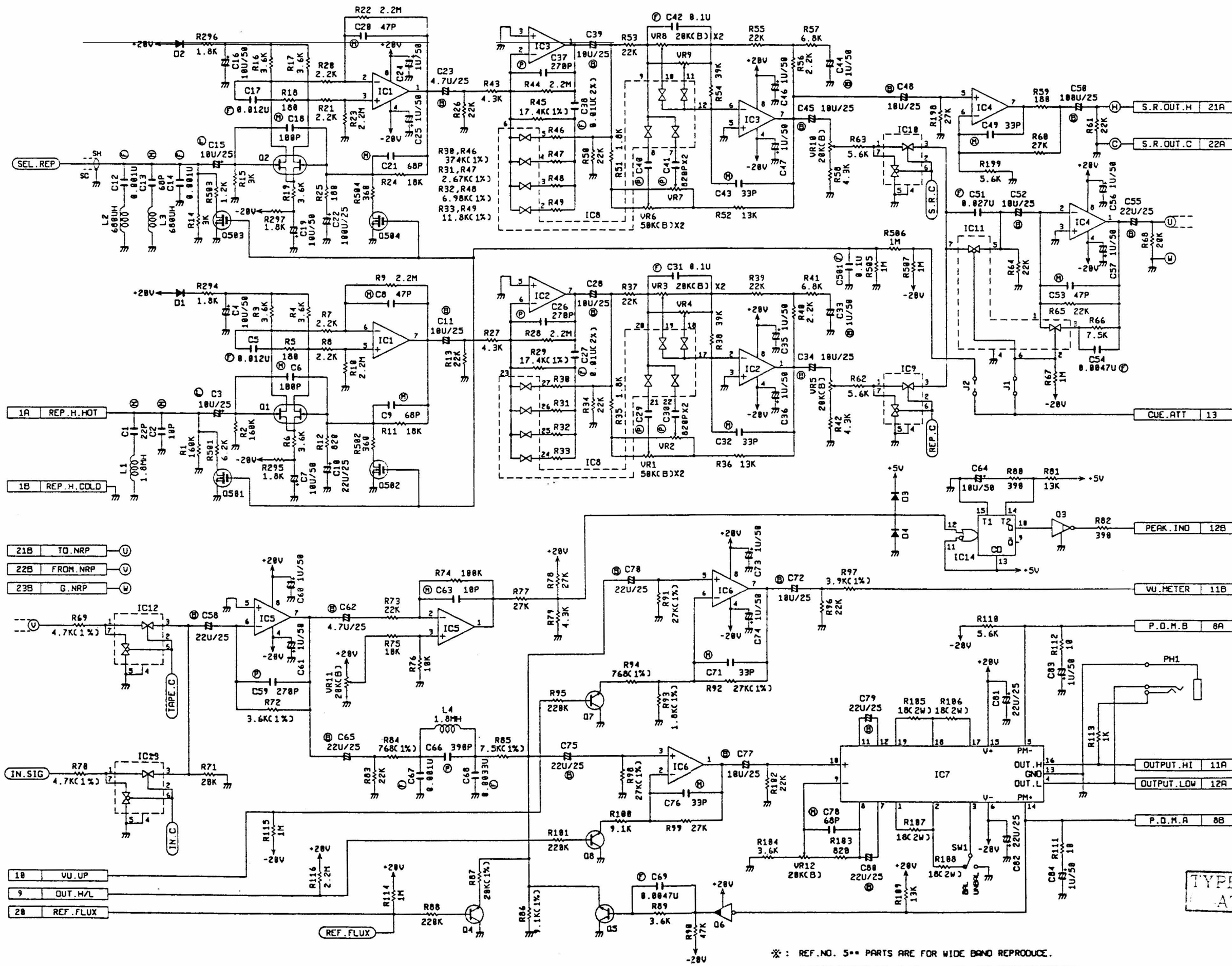

\*: REF.NO. 5\*\* PARTS ARE FOR WIDE BAND REPRODUCE.  
PLEASE CHANGE TO J2 FROM J1 AT WIDE BAND REPRODUCE.

| REF. NO. | OTARI PART NO. | DESCRIPTION |
|----------|----------------|-------------|
| Q501 4   | Q2SK336        | 2SK336      |

| NAME     | AUDIO AMP PCB<br>(PLAY BACK) | SHEET<br>1 OF 4 |
|----------|------------------------------|-----------------|
| PART NO. | PB19J0A                      |                 |
| APPLIED  | PB-19VA                      |                 |

Dwg. NO. 3 . 12735



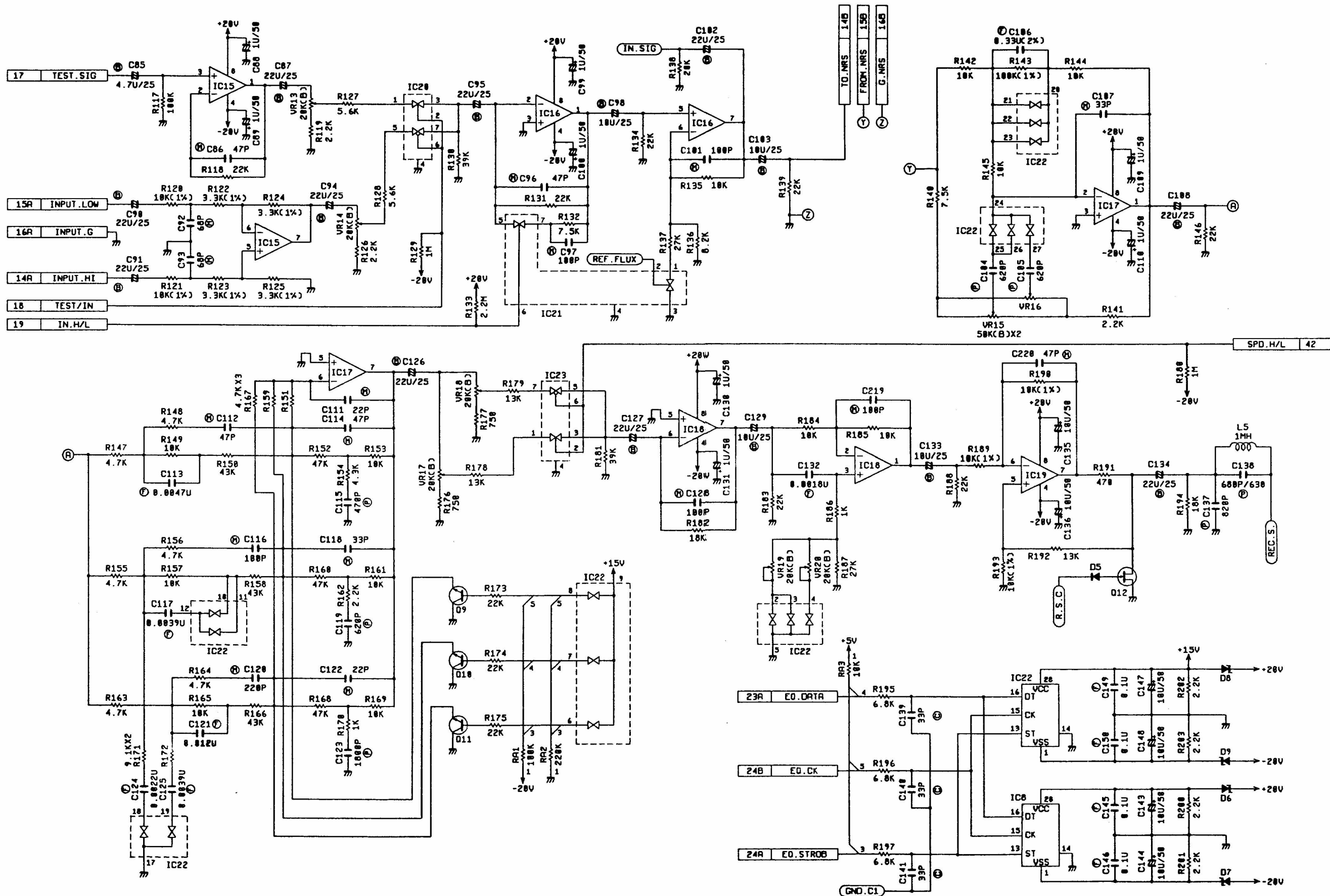

REPRODUCED FROM THE ORIGINAL

|          |                        |       |        |
|----------|------------------------|-------|--------|
| NAME     | AUDIO AMP PCA (RECORD) | SHEET | 2 of 4 |
| PART NO. | PB19J0A                |       |        |
| APPLIED  | PB-19JA                |       |        |

DWG. NO. 3 12736



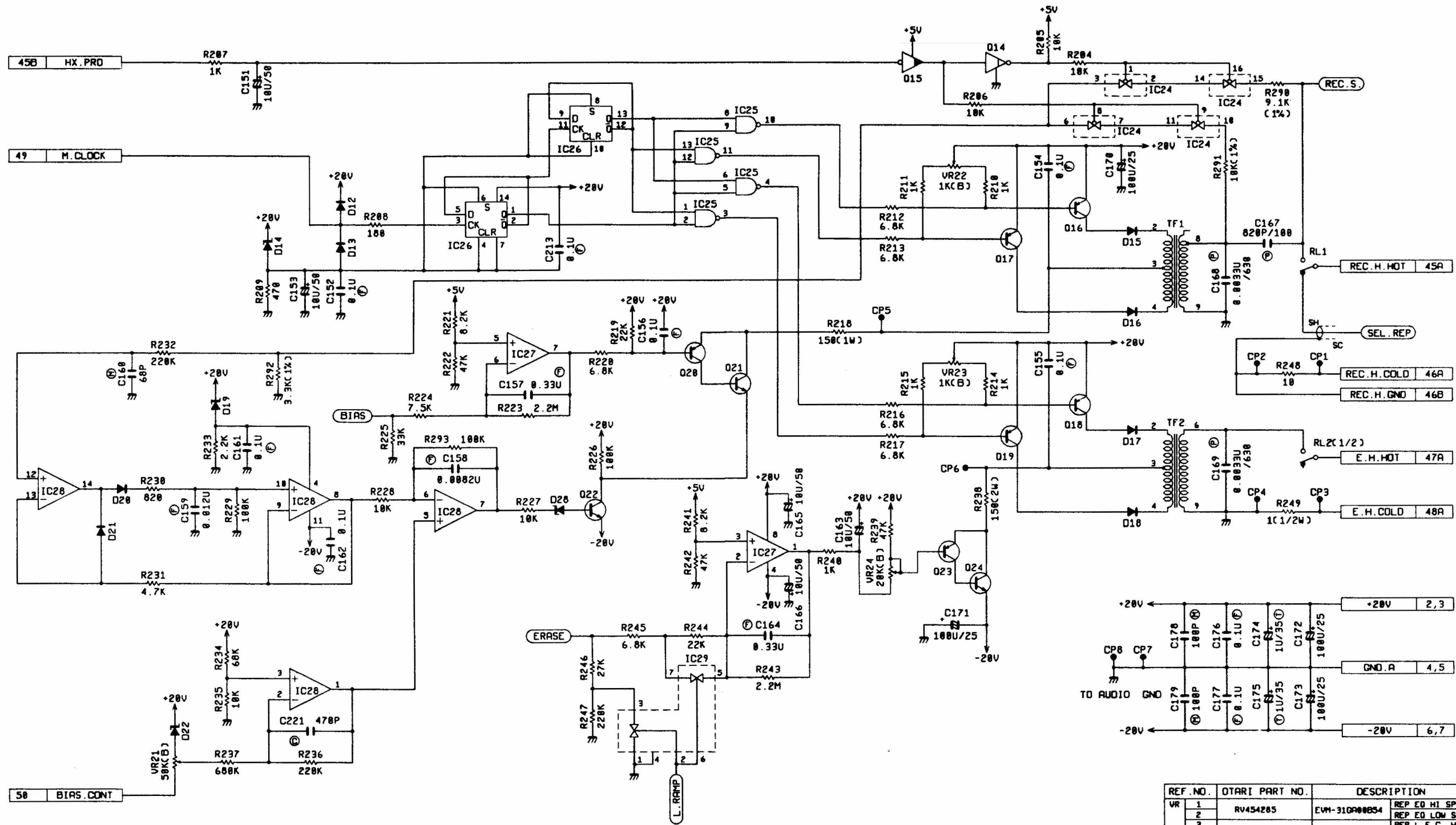

| REFERENCE NO.   | OTARI PART NO. | DESCRIPTION |
|-----------------|----------------|-------------|
| IC 1, 6, 15, 19 | 1-0067         | MS219P      |
| 27              | 1-0017         | NJM568DX    |
| 7               | 1-0125         | LINE OUTPUT |
|                 | 1-0058         | AMPLIFIER   |
| 8               | 1TC9164N       | TC9164N     |
| 9, 10, 12, 13   | 1-0133         | FET SW NP   |
| 11, 20, 23      | 1-0053         | FET SW NP   |
| 14              | 1MC14538       | MC14538B    |
| 21, 29          | 1-0051         | FET SW NN   |
| 22              | 1TC9163N       | TC9163N     |
| 24              | 1-0126         | NJU7301     |
| 25              | 1MC14011       | MC14011B    |
| 26, 31, 32      | 1MC14013       | MC14013B    |
| 28              | 1TL064DN       | TL064DN     |

| REFERENCE NO.  | OTARI PART NO. | DESCRIPTION |
|----------------|----------------|-------------|
| IC 30          | 1MC14584       | MC14584B    |
| 33             | 1-0056         | MODE CONT.  |
| 0 1, 2         | Q2K240BL       | ZSK240BL    |
| 3, 14          | 0-0008         | UM1211      |
| 25, 30, 39, 43 | 0-0008         | UM1211      |
| 4, 5, 7, 11    | OC3327B        | ZSC3327B    |
| 6, 15, 31, 30  | 0-0004         | UM1111      |
|                | 0-0004         | UM1111      |
| 12             | Q2K372BL       | ZSK372BL    |
| 16, 19         | QA720R         | PSA720R     |
| 20, 23         | QA1015GR       | PSA1015GR   |
| 21, 22, 24     | OC2653Y        | ZSC2653Y    |
| 40, 42         | OC1813BL       | ZSC1813BL   |

| REFERENCE NO.    | OTARI PART NO. | DESCRIPTION  |
|------------------|----------------|--------------|
| D 1, 2, 25, 27   | PN-0257        | SM1-X082     |
| 3, 5, 12, 13     | PN151588       | 1S1588       |
| 20, 21, 23, 24   | PN-0011        | RD5-1EB3     |
| 6, 9, 19, 22, 20 | PN-0044        | RD15EB3      |
| 14               | PN-0044        | RD15EB3      |
| 15, 10           | PN-0199        | MA171C TR    |
| L 1, 4           | IM19005        | 3500-182     |
| 2, 3             | IM19112        | 3640-601     |
| 5                | IM19123        | 3500-182     |
| RR 1, 5, 6       | R94-091        | MRNSR05P184J |
| 2, 7             | R94-095        | MRNSR05P24J  |
| 3                | R94-079        | MRNSR05P183J |
| 4                | R94-144        | MRNSR07P473J |

| REF. NO. | OTARI PART NO. | DESCRIPTION          |
|----------|----------------|----------------------|
| VR 1     | RV454285       | EVM-310A00854        |
| 2        |                | REP EQ HI SPD        |
| 3        |                | REP EQ LOW SPD       |
| 4        | RV424284       | EVM-310A00824        |
| 5        |                | REP L.F.C. HI SPD    |
| 6        |                | REP L.F.C. LOW SPD   |
| 7        |                | REP LEVEL            |
| 8        | RV454285       | EVM-310A00854        |
| 9        |                | S.REP EQ HI SPD      |
| 10       |                | S.REP EQ LOW SPD     |
| 11       |                | S.REP L.F.C. HI SPD  |
| 12       |                | S.REP L.F.C. LOW SPD |
| 13       | RV424297       | EVM-360A00824        |
| 14       |                | S.REP LEVEL          |
| 15       |                | PEAK IND. LEVEL      |
| 16       |                | OUTPUT LEVEL         |
| 17       |                | TEST SIG. LEVEL      |
| 18       | RV454285       | EVM-310A00854        |
| 19       |                | REC EQ HI SPD        |
| 20       |                | REC EQ LOW SPD       |
| 21       | RV424284       | EVM-310A00824        |
| 22       |                | REC LEVEL HI SPD     |
| 23       |                | REC LEVEL LOW SPD    |
| 24       |                | PHASE COMP HI SPD    |
| 25       |                | PHASE COMP LOW SPD   |
| 26       | RV454174       | EVM10A01054          |
| 27       |                | BIAS LEVEL           |
| 28       | RV413293       | EVM-360A00813        |
| 29       |                | BIAS SYMMETRY        |
| 30       |                | ERASE SYMMETRY       |
| 31       | RV424277       | EVM-360A00824        |
| 32       |                | ERASE CURRENT        |

TYPE NO(B) TO  
( ) AT THE END

|          |                      |              |
|----------|----------------------|--------------|
| NAME     | AUDIO AMP PCB (BIAS) | SHEET 3 OF 4 |
| PART NO. | PB19J0A              |              |
| APPLIED  | PB-19JA              |              |

Dwg. NO. 3 12739



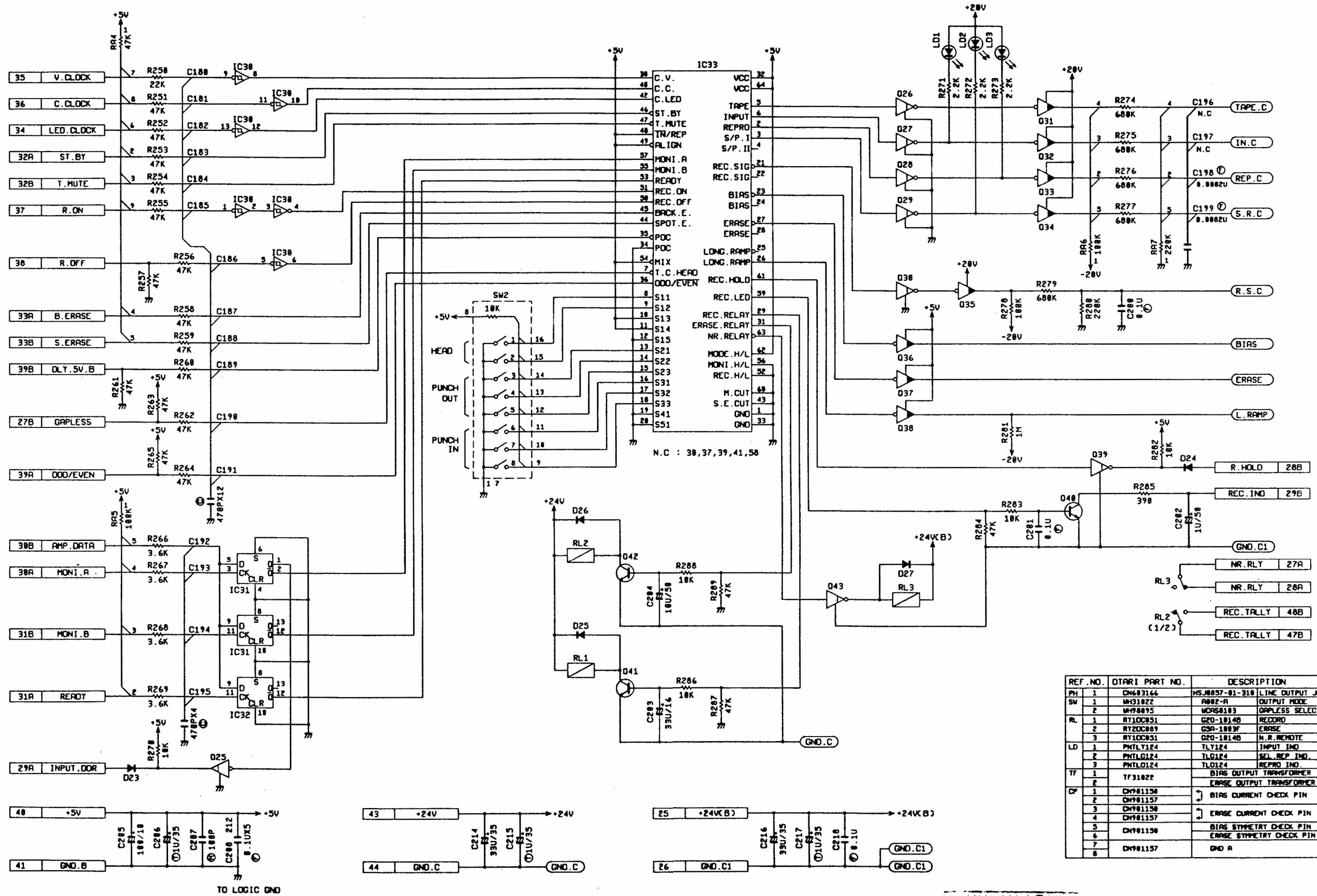

| REF. NO. | OTARI PART NO. | DESCRIPTION                     |
|----------|----------------|---------------------------------|
| PH 1     | CN683166       | HSJ8857-81-318 LINE OUTPUT JACK |
| SW 1     | W431822        | A882-A OUTPUT MODE              |
| 2        | W498895        | W498895 GAPLESS SELECT          |
| RL 1     | RY10C851       | G20-1814B RECORD                |
| 2        | RY20C889       | G3A-1883F ERASE                 |
| 3        | RY10C851       | G20-1814B N.R.REMOTE            |
| LD 1     | PH1L124        | TL124 INPUT IND.                |
| 2        | PH1L124        | TLG124 SEL.REP.IND.             |
| 3        | PH1L0124       | TL0124 REPRO IND.               |
| TF 1     | TF31822        | BIAS OUTPUT TRANSFORMER         |
| 2        |                | ERASE OUTPUT TRANSFORMER        |
| CP 1     | CN981158       | BIAS CURRENT CHECK PIN          |
| 2        | CN981157       | ERASE CURRENT CHECK PIN         |
| 3        | CN981158       | BIAS SYMMETRY CHECK PIN         |
| 4        | CN981157       | ERASE SYMMETRY CHECK PIN        |
| 5        | CN981158       | BIAS SYMMETRY CHECK PIN         |
| 6        |                | ERASE SYMMETRY CHECK PIN        |
| 7        |                | GND A                           |
| 8        | CN981157       | GND A                           |

|          |                         |              |
|----------|-------------------------|--------------|
| NAME     | AUDIO AMP PCA (CONTROL) | SHEET 4 OF 4 |
| PART NO. | PB19J0A                 |              |
| APPLIED  | PB-19JA                 |              |

DRG. NO. 3 12738



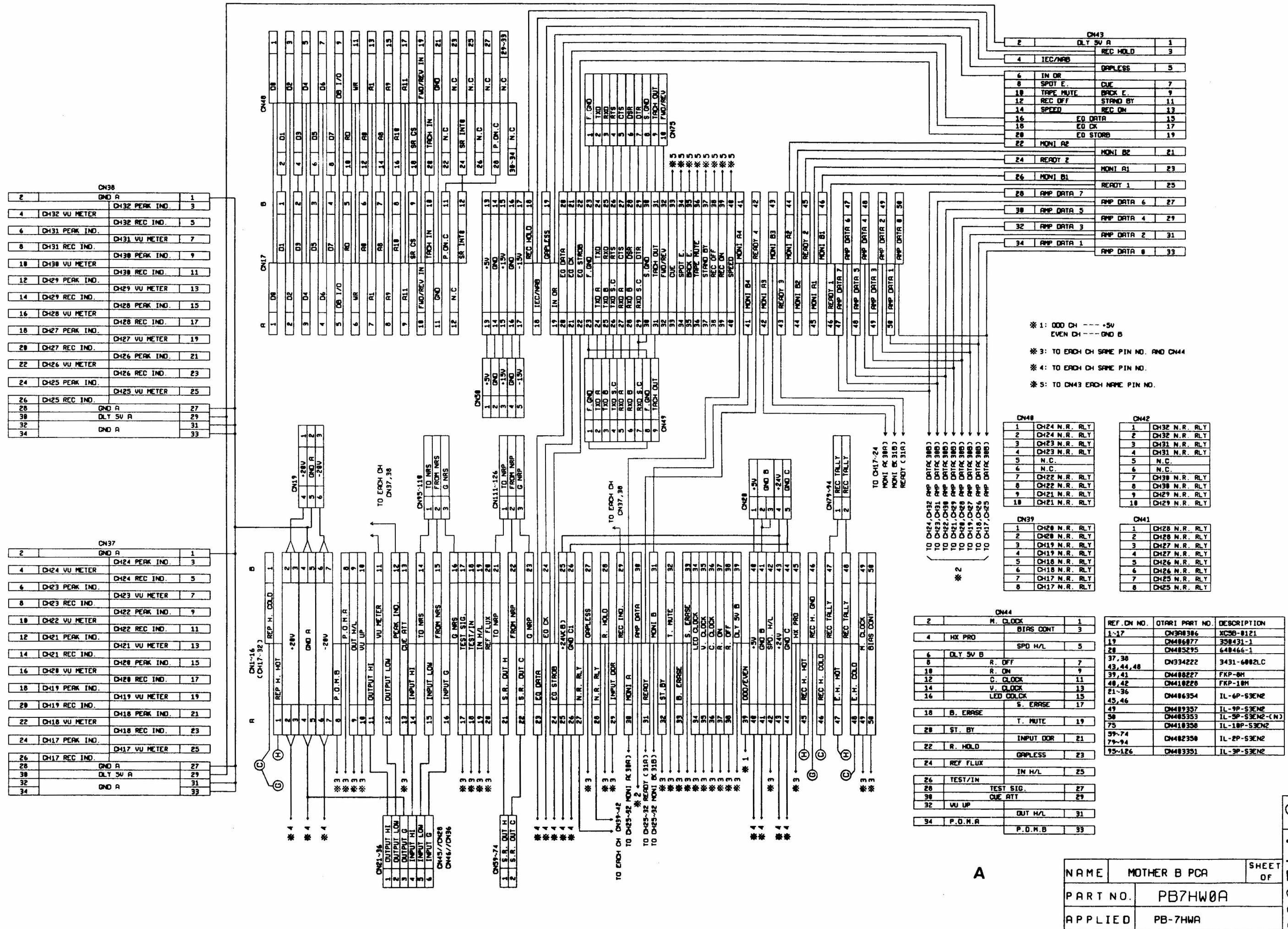

|          |              |          |
|----------|--------------|----------|
| NAME     | MOTHER B PCA | SHEET OF |
| PART NO. | PB7HW0A      |          |
| APPLIED  | PB-7HWA      |          |

3.12555



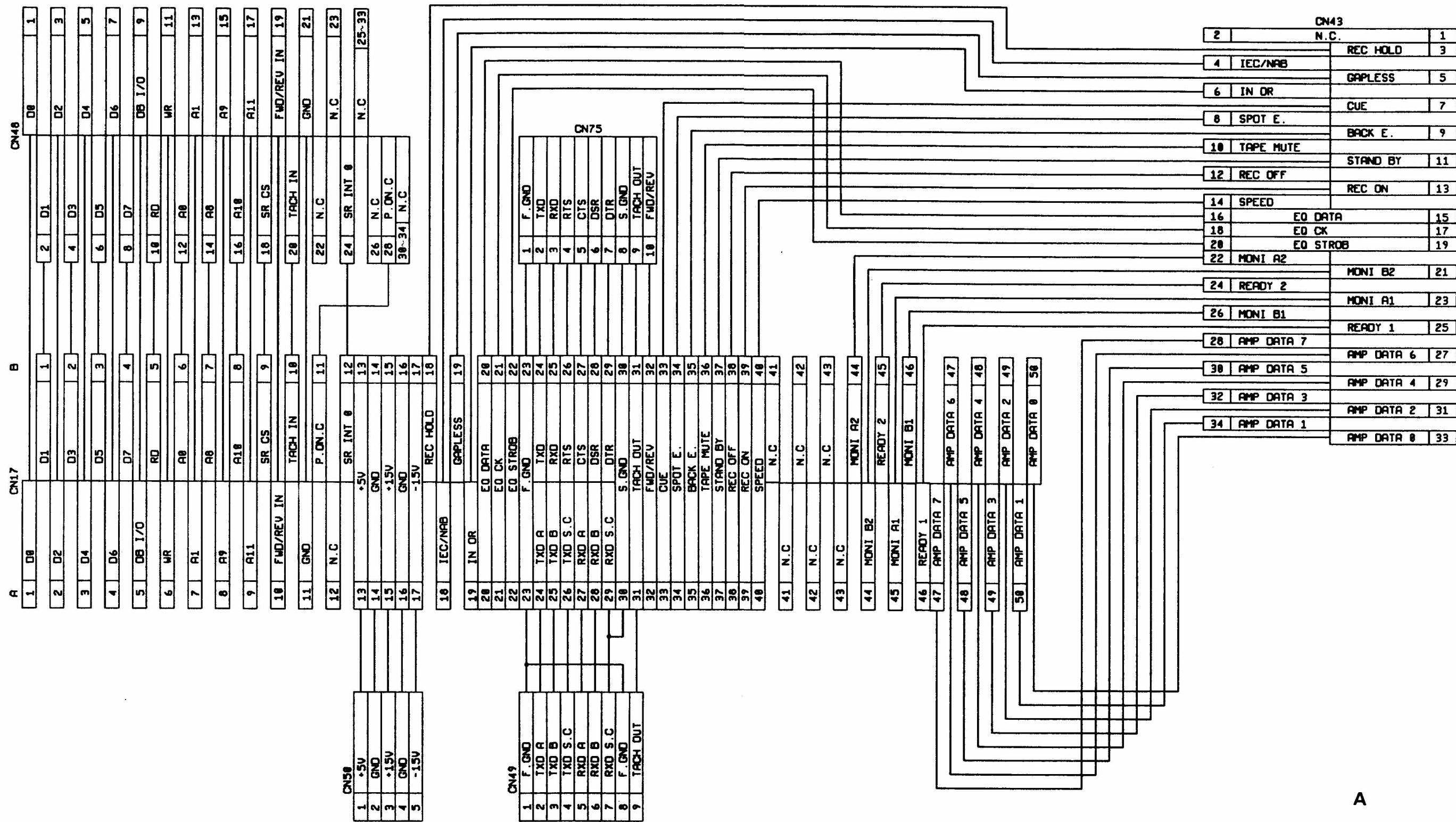

A

| REF. CN NO. | OTARI PART NO. | DESCRIPTION      |
|-------------|----------------|------------------|
| 17          | CN3A0306       | XC5B-0121        |
| 43,48       | CN334222       | 3431-6002LC      |
| 49          | CN409357       | IL-9P-S3EN2      |
| 50          | CN405353       | IL-5P-S3EN2-(CN) |
| 75          | CN410358       | IL-10P-S3EN2     |

|          |              |          |
|----------|--------------|----------|
| NAME     | MOTHER C PCA | SHEET OF |
| PART NO. | PB7KG0A      |          |
| APPLIED  | PB-7KGA      |          |

3. 12556



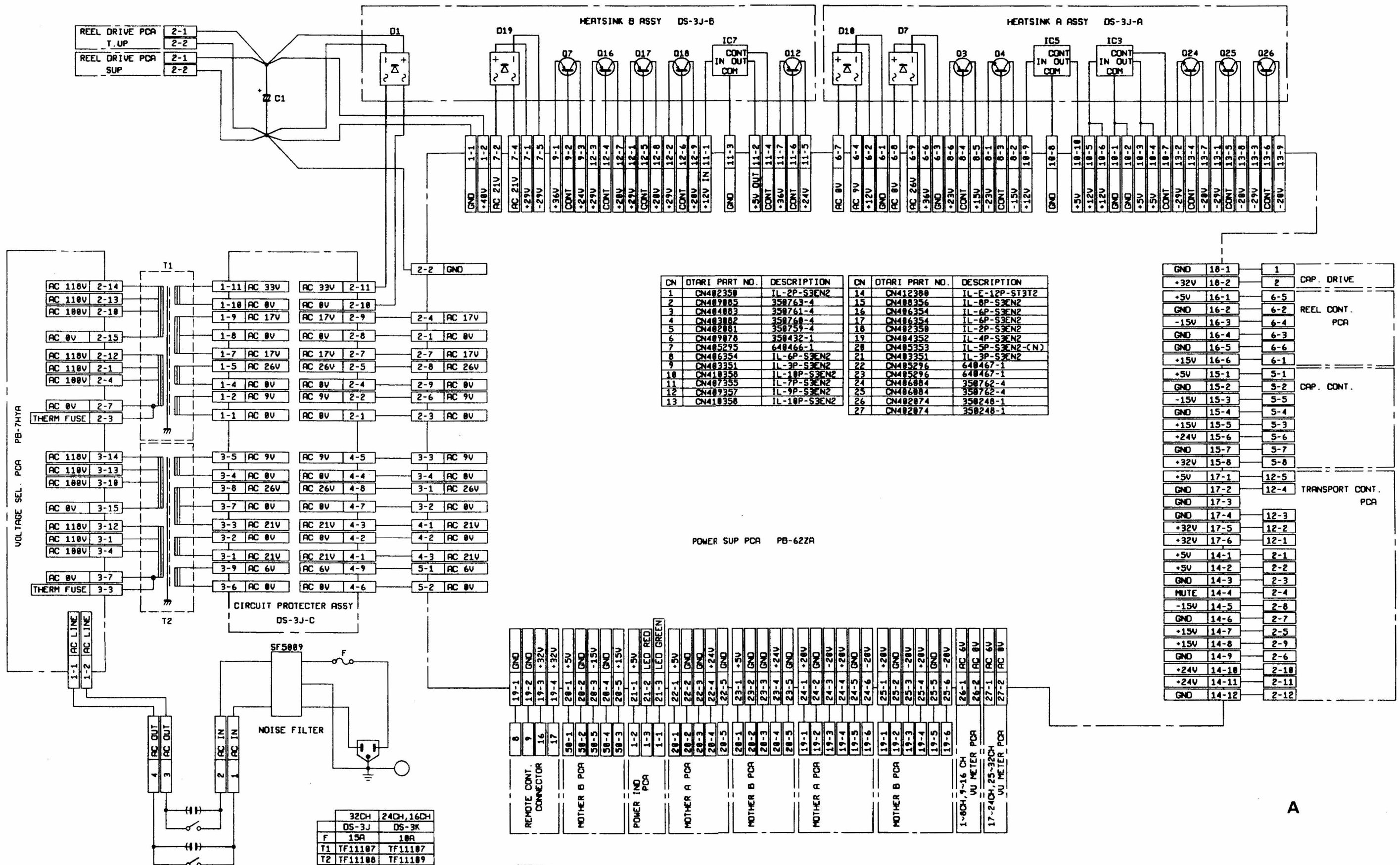

NOTES : UNLESS OTHERWISE SPECIFIED  
 1. RESISTANCE VALUES ARE IN OHMS. ±W. 5%.  
 2. CAPACITANCE VALUES ARE IN FARADS. 50V.  
 3. CAPACITOR SYMBOL MARKS ARE AS FOLLOWS.  
 \* : ALUMINUM ELECTROLYTIC CAPACITOR.  
 ⊕ : BIPOLAR ALUMINUM ELECTROLYTIC CAPACITOR.  
 ⊖ : MYLAR FILM CAPACITOR(±5%, 50V)  
 ⊙ : POLYSTYRENE FILM CAPACITOR(±5%, 50V)  
 ⊕ : CERAMIC CAPACITOR.  
 ⊙ : MICA CAPACITOR(±5%)  
 ⊕ : TANTALUM ELECTROLYTIC CAPACITOR.  
 ⊖ : POLYPROPYLENE FILM CAPACITOR(±5%)  
 ⊙ : LOW LEAKAGE CURRENT ELECTROLYTIC CAPACITOR.  
 ⊕ : METALLIZED PAPER CAPACITOR(±10%)  
 ⊖ : SPARK KILLER.  
 ⊕ : SAFETY COMPONENT : REPLACE ONLY WITH THE SPECIFIED COMPONENT FOR SAFETY REASON.

|          |                        |          |
|----------|------------------------|----------|
| NAME     | POWER SUP. ASSY WIRING | SHEET OF |
| PART NO. | DS3J00B                |          |
| APPLIED  | DS3J, DS3K             |          |

3. 12557



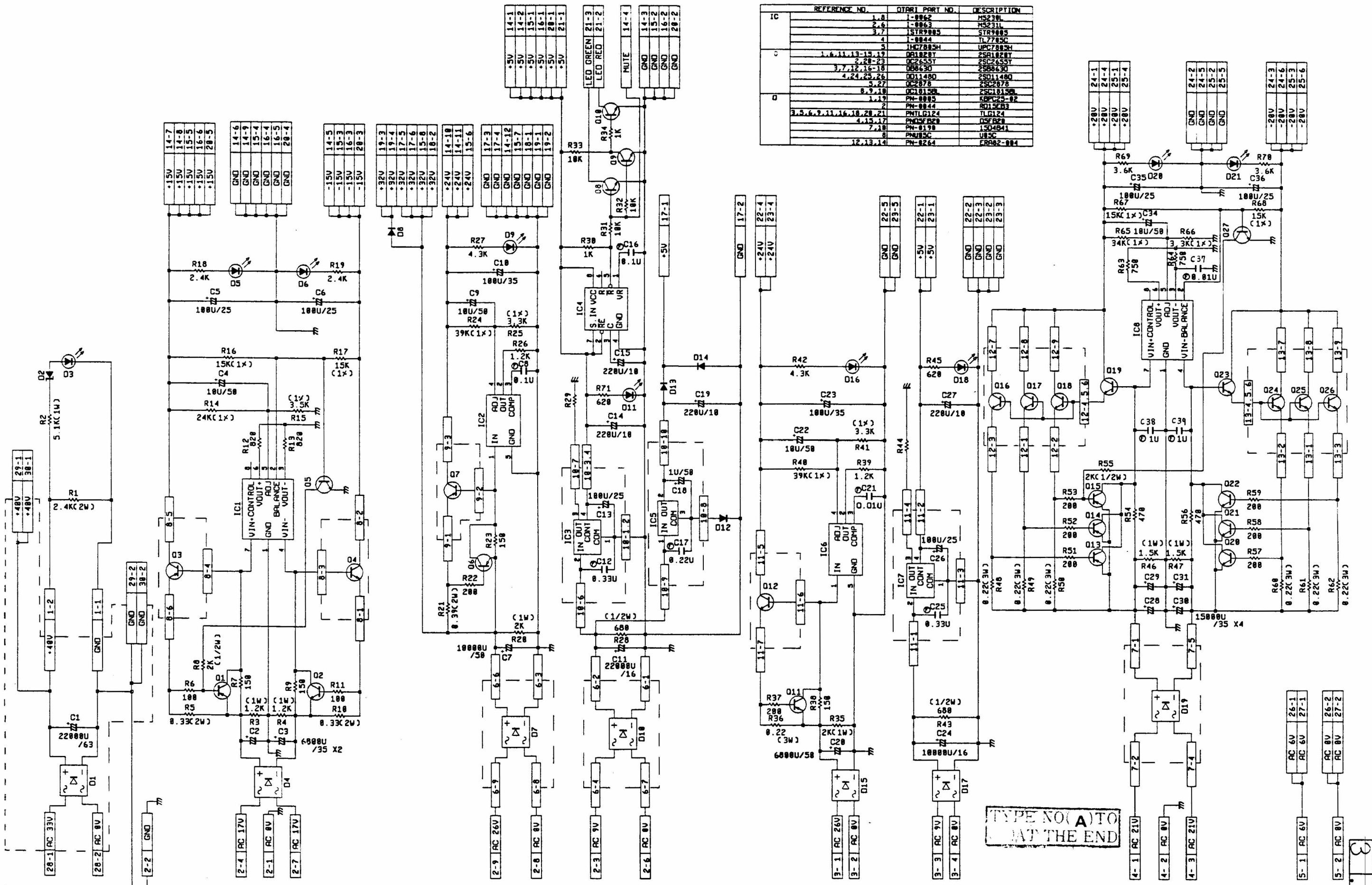

| IC | REFERENCE NO.          | QTY | PART NO. | DESCRIPTION |
|----|------------------------|-----|----------|-------------|
|    | 1,8                    | 1   | IC-0862  | MS231L      |
|    | 2,6                    | 1   | IC-0863  | MS231L      |
|    | 3,7                    | 1   | STR9005  | STR9005     |
|    | 4                      | 1   | IC-0844  | TL7785C     |
|    | 5                      | 1   | IC-0844  | TL7785C     |
|    | 1,6,11,13-15,19        | 1   | OP182BY  | 25S182BY    |
|    | 2,28-29                | 1   | OC2655Y  | 25C2655Y    |
|    | 3,7,12,16-18           | 1   | OC8630   | 25S8630     |
|    | 4,24,25,26             | 1   | OC11480  | 25S11480    |
|    | 5,27                   | 1   | OC11480  | 25S11480    |
|    | 8,9,10                 | 1   | OC11480  | 25S11480    |
|    | 1,19                   | 1   | PN-0885  | KPC25-02    |
|    | 2                      | 1   | PN-0844  | AD152B3     |
|    | 3,5,6,7,11,16,18,28,29 | 1   | PMTL124  | TL124       |
|    | 4,15,17                | 1   | PN0CFR28 | DSFR28      |
|    | 7,18                   | 1   | PN-0198  | LS04841     |
|    | 8                      | 1   | PN085C   | UE5C        |
|    | 12,13,14               | 1   | PN-0264  | CR02-004    |

NOTES: UNLESS OTHERWISE SPECIFIED  
 1. RESISTANCE VALUES ARE IN OHMS. ±W. 5%.  
 2. CAPACITANCE VALUES ARE IN FARADS. 50V.  
 3. CAPACITOR SYMBOL MARKS ARE AS FOLLOWS:  
 ⊕: ALUMINUM ELECTROLYTIC CAPACITOR.  
 ⊕⊕: BIPOLAR ALUMINUM ELECTROLYTIC CAPACITOR.  
 ⊕: MYLAR FILM CAPACITOR(±5%, 50V)  
 ⊕: POLYSTYRENE FILM CAPACITOR(±5%, 50V)  
 ⊕: CERAMIC CAPACITOR.  
 M: MICA CAPACITOR(±5%)

⊕: TANTALUM ELECTROLYTIC CAPACITOR.  
 ⊕⊕: POLYPROPYLENE FILM CAPACITOR(±5%)  
 ⊕: LOW LEAKAGE CURRENT ELECTROLYTIC CAPACITOR.  
 ⊕: METALLIZED PAPER CAPACITOR(±10%)  
 ⊕: SPARK KILLER.  
 ⊕: SAFETY COMPONENT: REPLACE ONLY WITH THE SPECIFIED COMPONENT FOR SAFETY REASON.

|          |                 |        |
|----------|-----------------|--------|
| NAME     | POWER SUP. ASSY | SHEET  |
| PART NO. | DS3J00A         | 1 OF 1 |
| APPLIED  | DS-3J DS-3K     |        |

3.12610



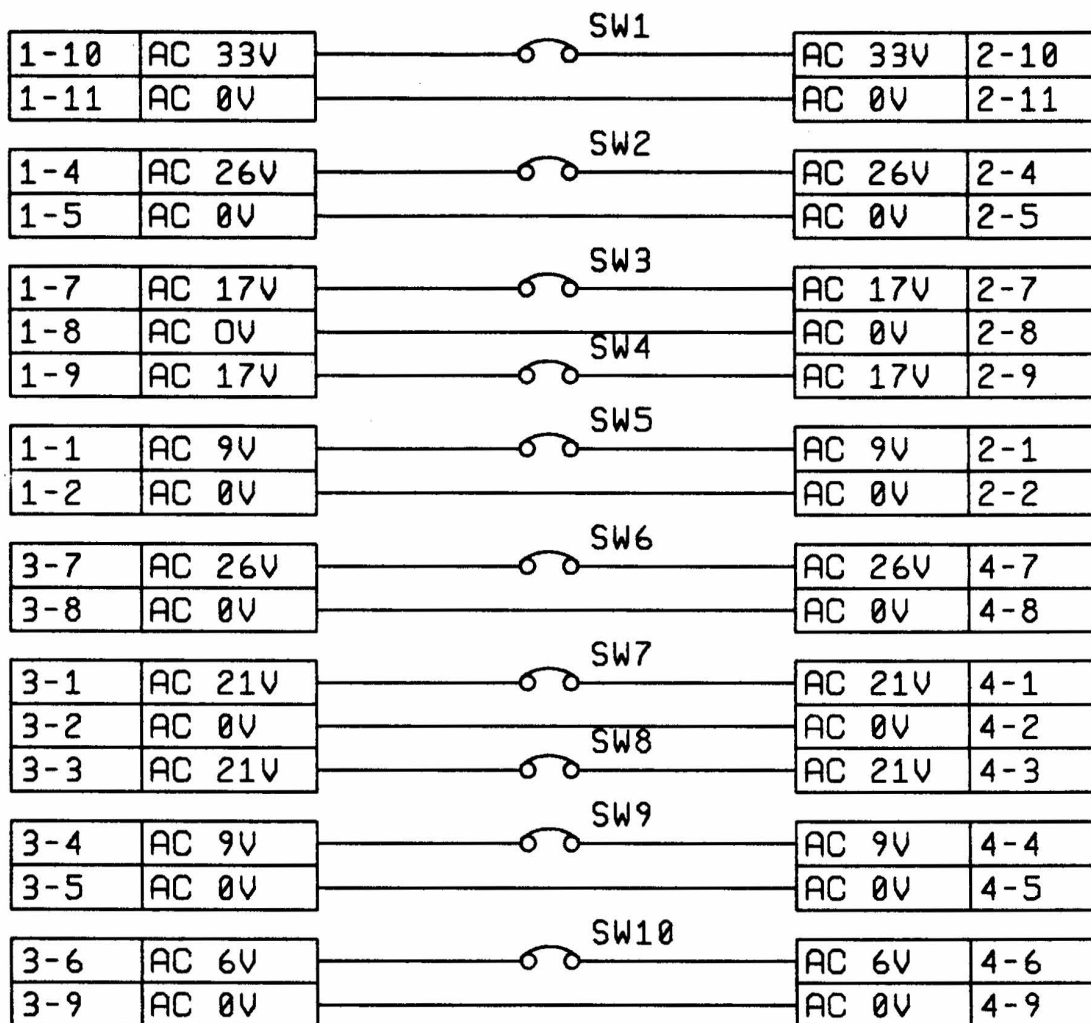

| REFERENCE NO |         | OTARI PART NO | DESCRIPTION | I[A]            |       |
|--------------|---------|---------------|-------------|-----------------|-------|
| DS-3K-A      | DS-3J-C |               |             |                 |       |
| SW           | 1,7,8   | 1             | WH91092     | TBC5001-01-1410 | 10A   |
|              | 2       | 2             | WH91091     | TBC5001-01-1310 | 8A    |
|              | 3,4     | 3,4           | WH91086     | TBC5001-01-0810 | 2.5A  |
|              | 5       | 5             | WH91090     | TBC5001-01-1210 | 6.3A  |
|              | 6,9     |               | WH91087     | TBC5001-01-0910 | 3.15A |
|              | 10      | 6,9           | WH91088     | TBC5001-01-1010 | 4A    |
|              |         | 10            | WH91089     | TBC5001-01-1110 | 5A    |
|              |         | 7,8           | WH91093     | TBC5001-01-1510 | 15A   |

|          |                        |
|----------|------------------------|
| NAME     | CIRCUIT PROTECTOR ASSY |
| PART NO. | DS3J00C                |
| APPLIED  | DS-3J-C                |

42936  
DWG. NO.

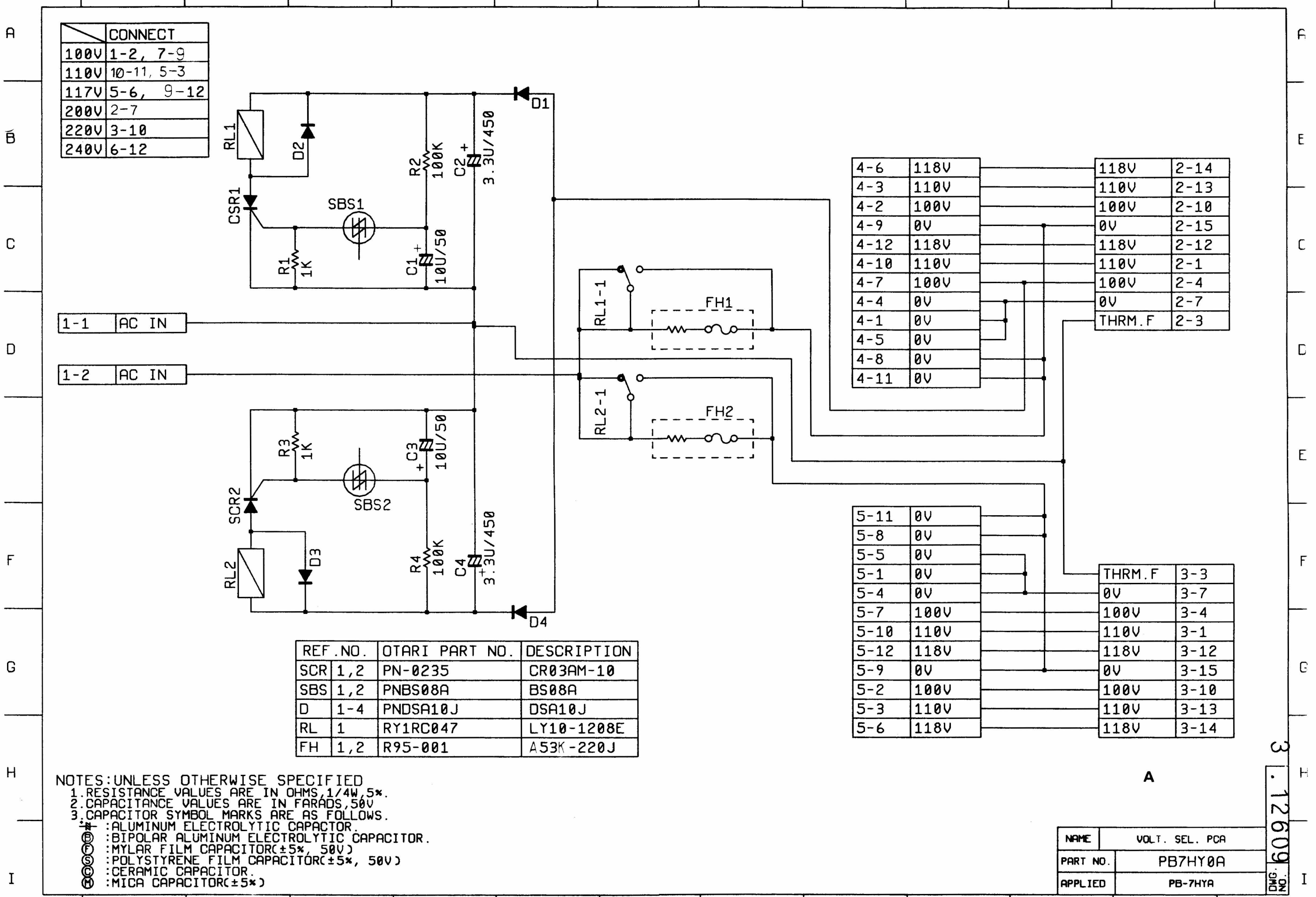

| CONNECT |            |
|---------|------------|
| 100V    | 1-2, 7-9   |
| 110V    | 10-11, 5-3 |
| 117V    | 5-6, 9-12  |
| 200V    | 2-7        |
| 220V    | 3-10       |
| 240V    | 6-12       |

|      |      |
|------|------|
| 4-6  | 118V |
| 4-3  | 110V |
| 4-2  | 100V |
| 4-9  | 0V   |
| 4-12 | 118V |
| 4-10 | 110V |
| 4-7  | 100V |
| 4-4  | 0V   |
| 4-1  | 0V   |
| 4-5  | 0V   |
| 4-8  | 0V   |
| 4-11 | 0V   |

|         |      |
|---------|------|
| 118V    | 2-14 |
| 110V    | 2-13 |
| 100V    | 2-10 |
| 0V      | 2-15 |
| 118V    | 2-12 |
| 110V    | 2-1  |
| 100V    | 2-4  |
| 0V      | 2-7  |
| THRM. F | 2-3  |

|      |      |
|------|------|
| 5-11 | 0V   |
| 5-8  | 0V   |
| 5-5  | 0V   |
| 5-1  | 0V   |
| 5-4  | 0V   |
| 5-7  | 100V |
| 5-10 | 110V |
| 5-12 | 118V |
| 5-9  | 0V   |
| 5-2  | 100V |
| 5-3  | 110V |
| 5-6  | 118V |

|         |      |
|---------|------|
| THRM. F | 3-3  |
| 0V      | 3-7  |
| 100V    | 3-4  |
| 110V    | 3-1  |
| 118V    | 3-12 |
| 0V      | 3-15 |
| 100V    | 3-10 |
| 110V    | 3-13 |
| 118V    | 3-14 |

| REF. NO. | OTARI PART NO. | DESCRIPTION |
|----------|----------------|-------------|
| SCR 1,2  | PN-0235        | CR03AM-10   |
| SBS 1,2  | PNBS08A        | BS08A       |
| D 1-4    | PNDSA10J       | DSA10J      |
| RL 1     | RY1RC047       | LY10-1208E  |
| FH 1,2   | R95-001        | A53K-220J   |

NOTES: UNLESS OTHERWISE SPECIFIED  
 1. RESISTANCE VALUES ARE IN OHMS, 1/4W, 5%.  
 2. CAPACITANCE VALUES ARE IN FARADS, 50V.  
 3. CAPACITOR SYMBOL MARKS ARE AS FOLLOWS.  
 \* : ALUMINUM ELECTROLYTIC CAPACITOR.  
 @ : BIPOLAR ALUMINUM ELECTROLYTIC CAPACITOR.  
 F : MYLAR FILM CAPACITOR (±5%, 50V)  
 S : POLYSTYRENE FILM CAPACITOR (±5%, 50V)  
 C : CERAMIC CAPACITOR.  
 M : MICA CAPACITOR (±5%)

| NAME     | VOLT. SEL. PCA |
|----------|----------------|
| PART NO. | PB7HY0A        |
| APPLIED  | PB-7HYA        |

3. 12609  
DWG. NO.

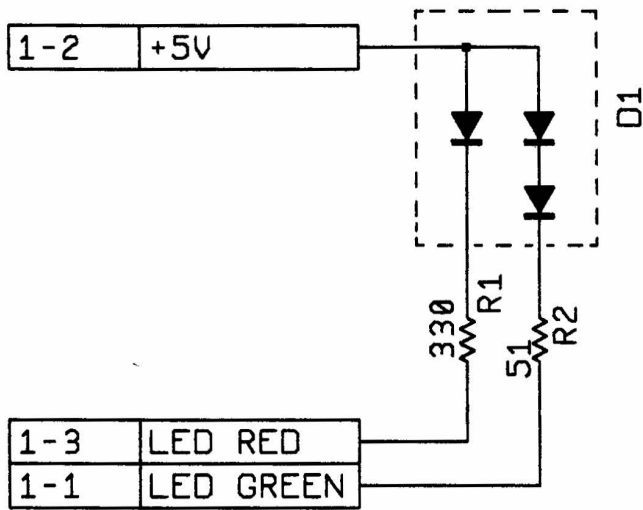

| REF. NO. | QTARI | PART NO | DESCRIPTION |
|----------|-------|---------|-------------|
| D        | 1     | PN-0276 | MU09-9101   |

|          |               |
|----------|---------------|
| NAME     | POWER IND PCA |
| PART NO. | PB7HZ0A       |
| APPLIED  | PB-7HZA       |

4  
 42935  
 DWG. NO.



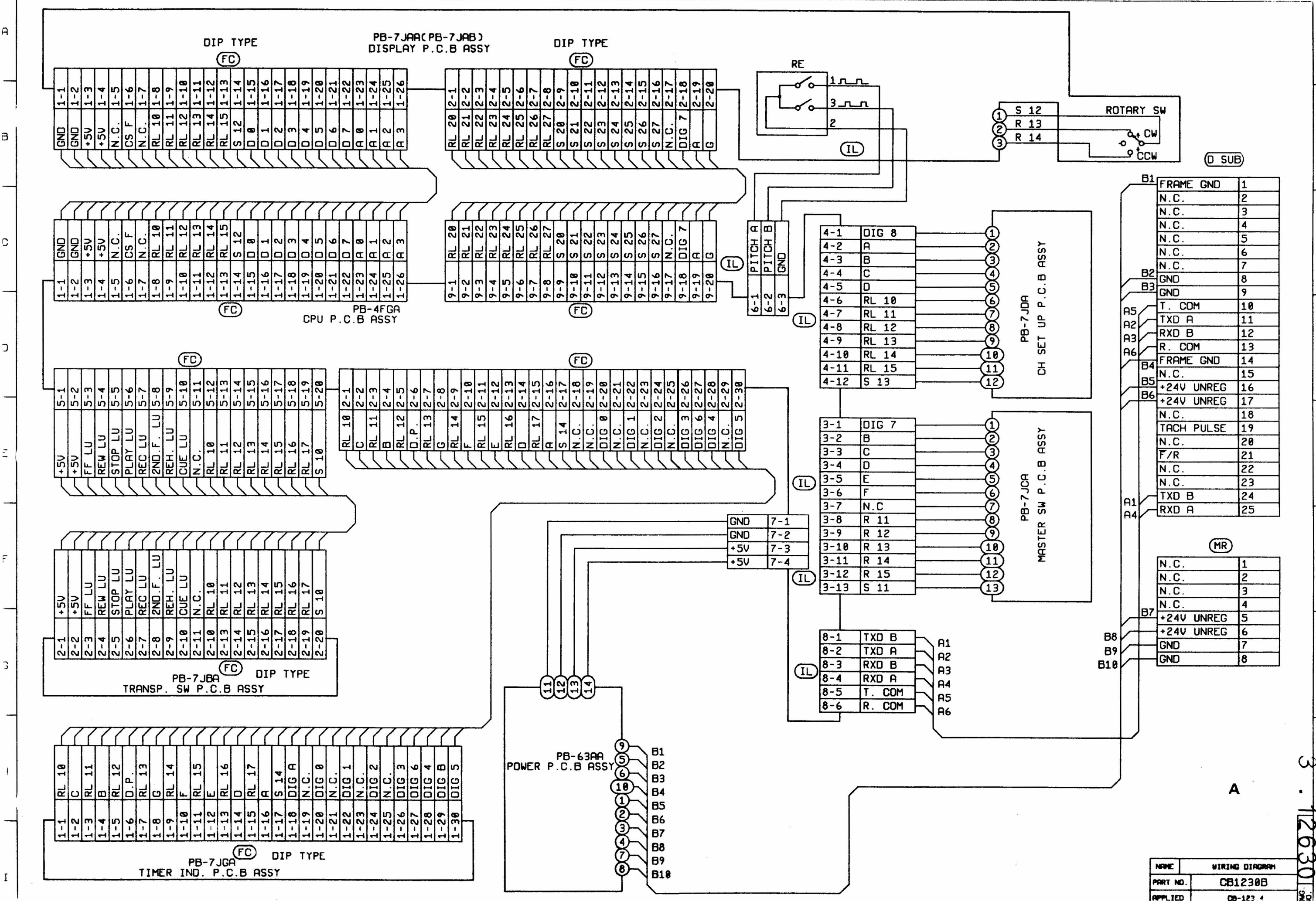

|    |            |    |
|----|------------|----|
| B1 | FRAME GND  | 1  |
|    | N.C.       | 2  |
|    | N.C.       | 3  |
|    | N.C.       | 4  |
|    | N.C.       | 5  |
|    | N.C.       | 6  |
|    | N.C.       | 7  |
|    | GND        | 8  |
|    | GND        | 9  |
| A5 | T. COM     | 10 |
| A2 | TXD A      | 11 |
| A3 | RXD B      | 12 |
| A6 | R. COM     | 13 |
|    | FRAME GND  | 14 |
| B4 | N.C.       | 15 |
| B5 | +24V UNREG | 16 |
| B6 | +24V UNREG | 17 |
|    | N.C.       | 18 |
|    | TACH PULSE | 19 |
|    | N.C.       | 20 |
|    | F/R        | 21 |
|    | N.C.       | 22 |
|    | N.C.       | 23 |
| A1 | TXD B      | 24 |
| A4 | RXD A      | 25 |

  

|    |            |   |
|----|------------|---|
|    | N.C.       | 1 |
|    | N.C.       | 2 |
|    | N.C.       | 3 |
|    | N.C.       | 4 |
| B7 | +24V UNREG | 5 |
|    | +24V UNREG | 6 |
| B8 | GND        | 7 |
| B9 | GND        | 8 |

|          |                |
|----------|----------------|
| NAME     | WIRING DIAGRAM |
| PART NO. | CB1230B        |
| APPLIED  | CB-123 4       |

3. 126301



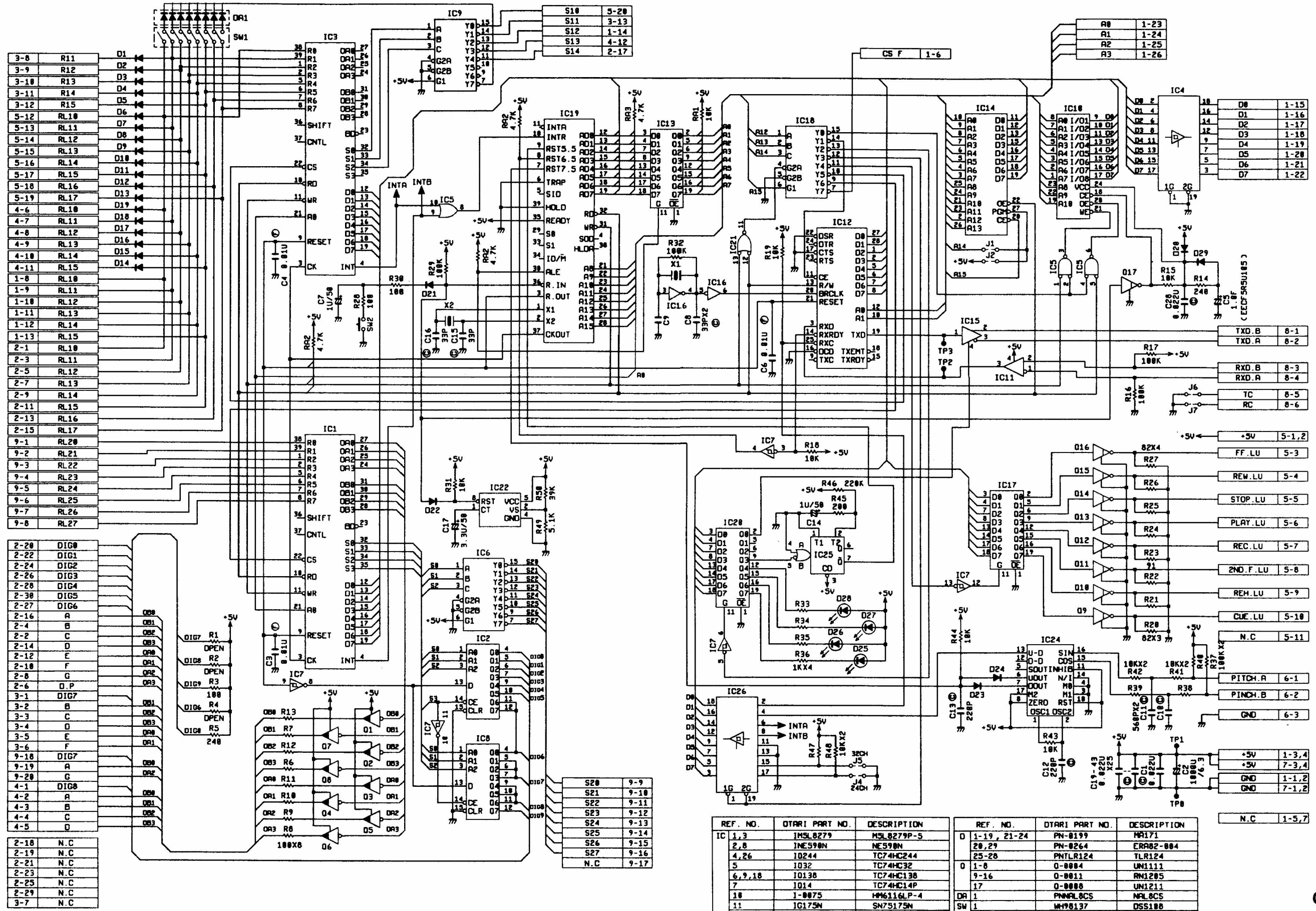

|      |      |      |
|------|------|------|
| 3-8  | RL1  | D1   |
| 3-9  | RL2  | D2   |
| 3-10 | RL3  | D3   |
| 3-11 | RL4  | D4   |
| 3-12 | RL5  | D5   |
| 5-12 | RL10 | D6   |
| 5-13 | RL11 | D7   |
| 5-14 | RL12 | D8   |
| 5-15 | RL13 | D9   |
| 5-16 | RL14 | D10  |
| 5-17 | RL15 | D11  |
| 5-18 | RL16 | D12  |
| 5-19 | RL17 | D13  |
| 4-6  | RL18 | D14  |
| 4-7  | RL19 | D15  |
| 4-8  | RL20 | D16  |
| 4-9  | RL21 | D17  |
| 4-10 | RL22 | D18  |
| 4-11 | RL23 | D19  |
| 1-8  | RL24 | D20  |
| 1-9  | RL25 | D21  |
| 1-10 | RL26 | D22  |
| 1-11 | RL27 | D23  |
| 1-12 | RL28 | D24  |
| 1-13 | RL29 | D25  |
| 2-1  | RL30 | D26  |
| 2-2  | RL31 | D27  |
| 2-3  | RL32 | D28  |
| 2-5  | RL33 | D29  |
| 2-7  | RL34 | D30  |
| 2-9  | RL35 | D31  |
| 2-11 | RL36 | D32  |
| 2-13 | RL37 | D33  |
| 2-15 | RL38 | D34  |
| 9-1  | RL39 | D35  |
| 9-2  | RL40 | D36  |
| 9-3  | RL41 | D37  |
| 9-4  | RL42 | D38  |
| 9-5  | RL43 | D39  |
| 9-6  | RL44 | D40  |
| 9-7  | RL45 | D41  |
| 9-8  | RL46 | D42  |
| 2-20 | DIG0 | OB0  |
| 2-22 | DIG1 | OB1  |
| 2-24 | DIG2 | OB2  |
| 2-26 | DIG3 | OB3  |
| 2-28 | DIG4 | OB4  |
| 2-30 | DIG5 | OB5  |
| 2-27 | DIG6 | OB6  |
| 2-16 | A    | OB7  |
| 2-4  | B    | OB8  |
| 2-2  | C    | OB9  |
| 2-14 | D    | OB10 |
| 2-12 | E    | OB11 |
| 2-10 | F    | OB12 |
| 2-8  | G    | OB13 |
| 3-1  | DIG7 | OB14 |
| 3-2  | B    | OB15 |
| 3-3  | C    | OB16 |
| 3-4  | D    | OB17 |
| 3-5  | E    | OB18 |
| 3-6  | F    | OB19 |
| 9-18 | DIG7 | OB20 |
| 9-19 | A    | OB21 |
| 9-20 | G    | OB22 |
| 4-1  | DIG8 | OB23 |
| 4-2  | A    | OB24 |
| 4-3  | B    | OB25 |
| 4-4  | C    | OB26 |
| 4-5  | D    | OB27 |
| 2-18 | N.C  |      |
| 2-19 | N.C  |      |
| 2-21 | N.C  |      |
| 2-23 | N.C  |      |
| 2-25 | N.C  |      |
| 2-29 | N.C  |      |
| 3-7  | N.C  |      |

NOTES : UNLESS OTHERWISE SPECIFIED  
 1. RESISTANCE VALUES ARE IN OHMS, K $\Omega$ , M $\Omega$ .  
 2. CAPACITANCE VALUES ARE IN FARADS,  $\mu$ F, nF.  
 3. CAPACITOR SYMBOL MARKS ARE AS FOLLOWS:  
 - $\square$ - ALUMINUM ELECTROLYTIC CAPACITOR.  
 - $\square$ - BIPOLAR ALUMINUM ELECTROLYTIC CAPACITOR.  
 - $\square$ - NYLON FILM CAPACITOR (5%  $\pm$  5%).  
 - $\square$ - POLYSTYRENE FILM CAPACITOR (5%  $\pm$  5%).  
 - $\square$ - CERAMIC CAPACITOR.  
 - $\square$ - MICRA CAPACITOR ( $\pm$  3%).

$\square$  : TANTALUM ELECTROLYTIC CAPACITOR  
 $\square$  : POLYPROPYLENE FILM CAPACITOR ( $\pm$  5%)  
 $\square$  : LOW LEAKAGE CURRENT ELECTROLYTIC CAPACITOR.  
 $\square$  : METALLIZED PAPER CAPACITOR ( $\pm$  10%)  
 $\square$  : SPARK KILLER.  
 $\square$  : SAFETY COMPONENT : REPLACE ONLY WITH THE SPECIFIED COMPONENT FOR SAFETY REASON.

| REF. NO. | DTARI PART NO. | DESCRIPTION   |
|----------|----------------|---------------|
| IC 1,3   | INSL8279       | MSL8279P-5    |
| 2,8      | INL590N        | NE590N        |
| 4,26     | 10244          | TC74HC244     |
| 5        | 1032           | TC74HC32      |
| 6,9,18   | 10130          | TC74HC138     |
| 7        | 1014           | TC74HC14P     |
| 18       | I-0075         | HM6116LP-4    |
| 11       | IG175N         | SN75175N      |
| 12       | I-0081         | SON2661BC1N28 |
| 13,17,20 | 10373          | TC74HC373P    |
| 14       | I-0065         | MSL27128K     |
| 15       | IG174N         | SN75174       |
| 16       | 10084          | TC74HC04P     |
| 19       | INSL8005       | MSH8005ARS    |
| 21       | 1008           | TC74HC00P     |
| 22       | I-0105         | TL7700CP      |
| 24       | I-0188         | MSM5210RS     |
| 25       | INC14538       | MC14538B      |

| REF. NO.      | DTARI PART NO. | DESCRIPTION |
|---------------|----------------|-------------|
| D 1-19, 21-24 | PN-0199        | HA171       |
| 20,29         | PN-0264        | ERAB2-004   |
| 25-28         | PNTLR124       | TLR124      |
| D 1-8         | 0-0004         | UN1111      |
| 9-16          | 0-0011         | AN1205      |
| 17            | 0-0008         | UN1211      |
| DR 1          | PNNAL8CS       | NAL8CS      |
| SW 1          | WH90137        | DSS188      |
| 2             | WH11181        | TM1-01      |
|               | WH08104R       | TZ-0002     |
| X 1           | PZ4C033        | 4.7152MHz   |
| 2             | PZ4C017        | KBR-6.0M    |

|          |         |          |
|----------|---------|----------|
| NAME     | CPU PCA | SHEET OF |
| PART NO. | PB4FG0A | 12619    |
| APPLIED  | PB-4FGA |          |



|    |       |
|----|-------|
| J1 | OPEN  |
| J2 | SHORT |
| J3 | SHORT |
| J4 | SHORT |

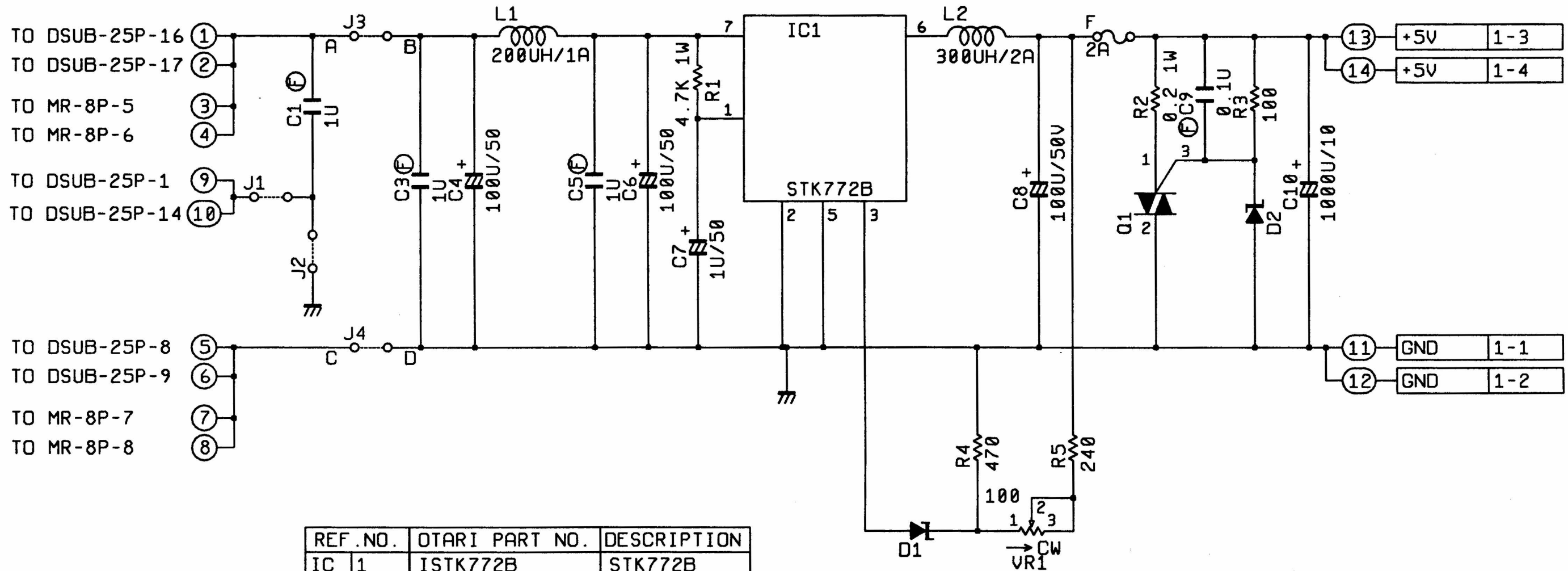

| REF. NO. | OTARI PART NO. | DESCRIPTION |
|----------|----------------|-------------|
| IC 1     | ISTK772B       | STK772B     |
| L 1      | IN19143        | HP-012      |
|          | IN19079        | HP-023      |
| Q 1      | Q-0016         | BCR6AM-8L   |
| D 1      | PNHZ2CLL       | HZ2CLL      |
|          | PN-0013        | RD.6EB2     |
| F        | FH1-014        | 85PN0819    |
|          | FH9-021        | CEA-0002    |

NOTES: UNLESS OTHERWISE SPECIFIED  
 1. RESISTANCE VALUES ARE IN OHMS, 1/4W, 5%.  
 2. CAPACITANCE VALUES ARE IN FARADS, 50V  
 3. CAPACITOR SYMBOL MARKS ARE AS FOLLOWS.  
 \* : ALUMINUM ELECTROLYTIC CAPACITOR.  
 ⊕ : BIPOLAR ALUMINUM ELECTROLYTIC CAPACITOR.  
 ⊖ : MYLAR FILM CAPACITOR(±5%, 50V)  
 ⊙ : POLYSTYRENE FILM CAPACITOR(±5%, 50V)  
 ⊕ : CERAMIC CAPACITOR.  
 ⊖ : MICA CAPACITOR(±5%)

REV. C

|          |               |
|----------|---------------|
| NAME     | POWER SUP PCA |
| PART NO. | PB63A0A       |
| APPLIED  | PB-63AA       |

DWG. NO. 3 . 12622



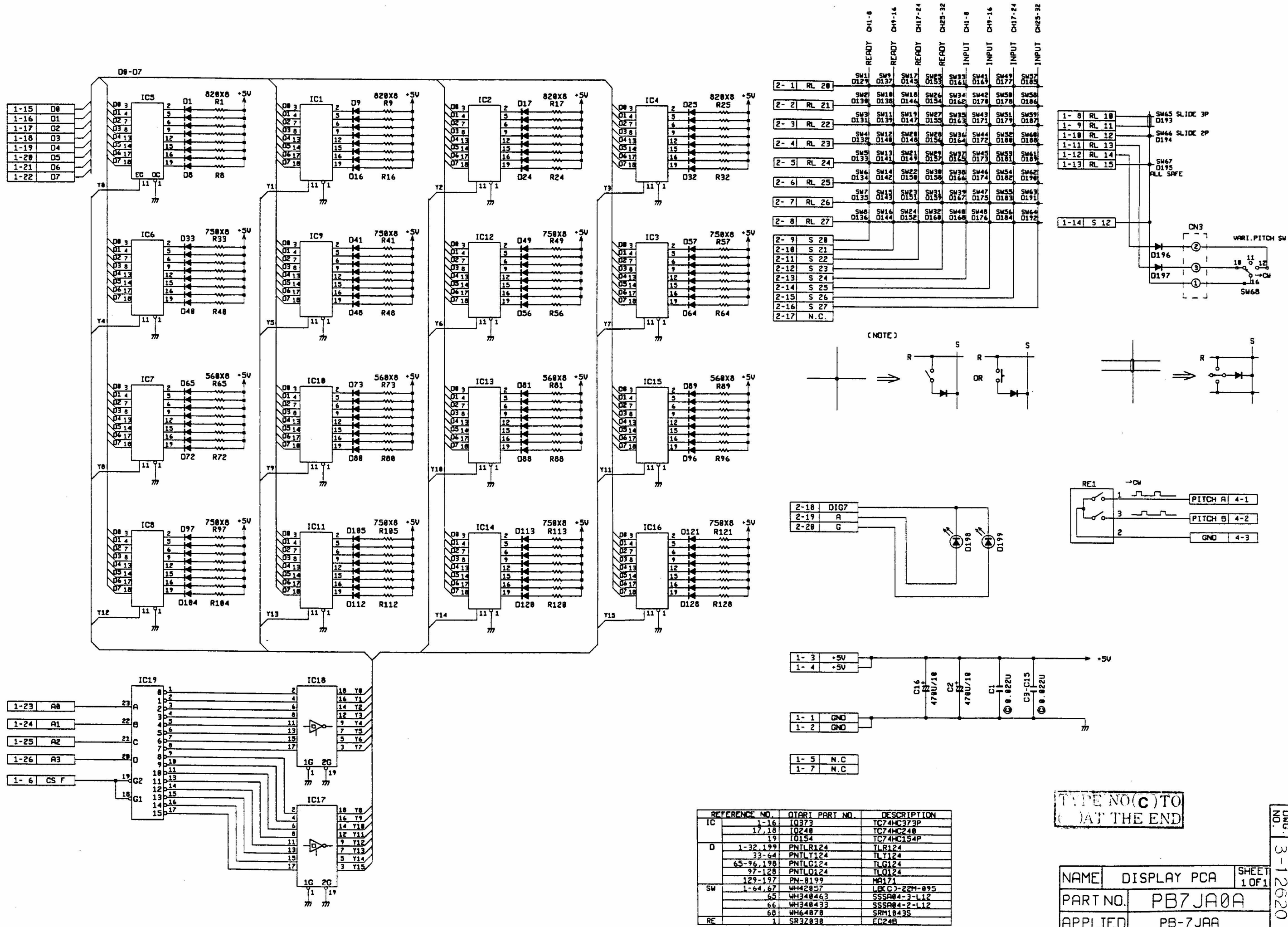

A  
B  
C  
D  
F  
G  
H  
I

F  
E  
C  
D  
E  
F  
G  
H  
I

|      |           |
|------|-----------|
| 1-1  | +5V       |
| 1-2  | +5V       |
| 1-3  | FF LU     |
| 1-4  | REW LU    |
| 1-5  | STOP LU   |
| 1-6  | PLAY LU   |
| 1-7  | REC LU    |
| 1-8  | 2ND F. LU |
| 1-9  | REH. LU   |
| 1-10 | CUE LU    |
| 1-11 | N.C.      |
| 1-12 | RL 10     |
| 1-13 | RL 11     |
| 1-14 | RL 12     |
| 1-15 | RL 13     |
| 1-16 | RL 14     |
| 1-17 | RL 15     |
| 1-18 | RL 16     |
| 1-19 | RL 17     |
| 1-20 | S 10      |

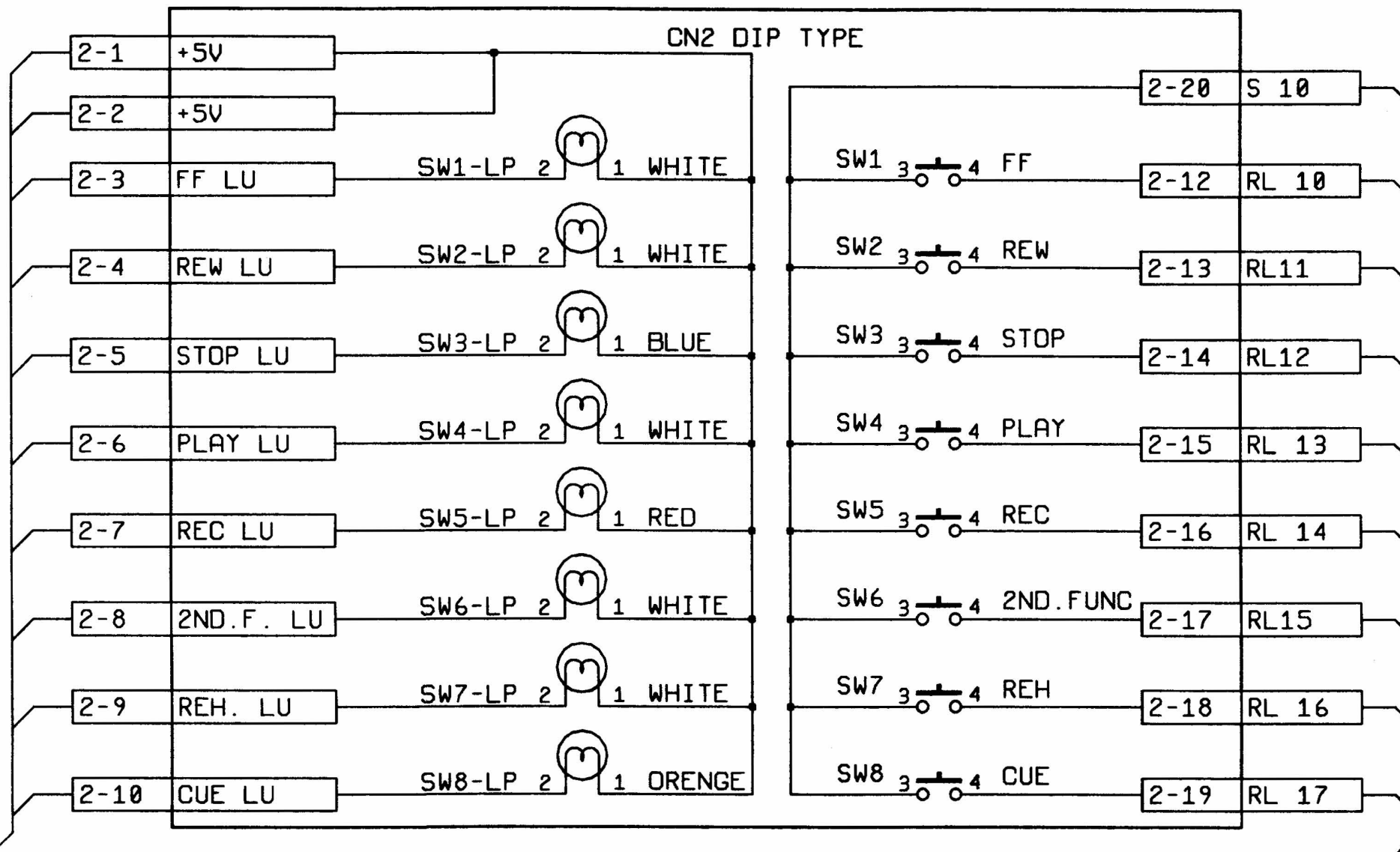

| REF. NO. | OTARI PART NO. | DESCRIPTION  |
|----------|----------------|--------------|
| SW 1-2   | WH11118W       | 11L-120-0000 |
| 3        | WH11117U       | 11L-170-0020 |
| 4,6,7    | WH11117W       | 11L-170-0000 |
| 5        | WH11117R       | 11L-170-0010 |
| 8        | WH111180       | 11L-120-0040 |

|          |                |
|----------|----------------|
| NAME     | TRANSP. SW PCB |
| PART NO. | PB7JB0A        |
| APPLIED  | PB-7JBA        |

3.12625



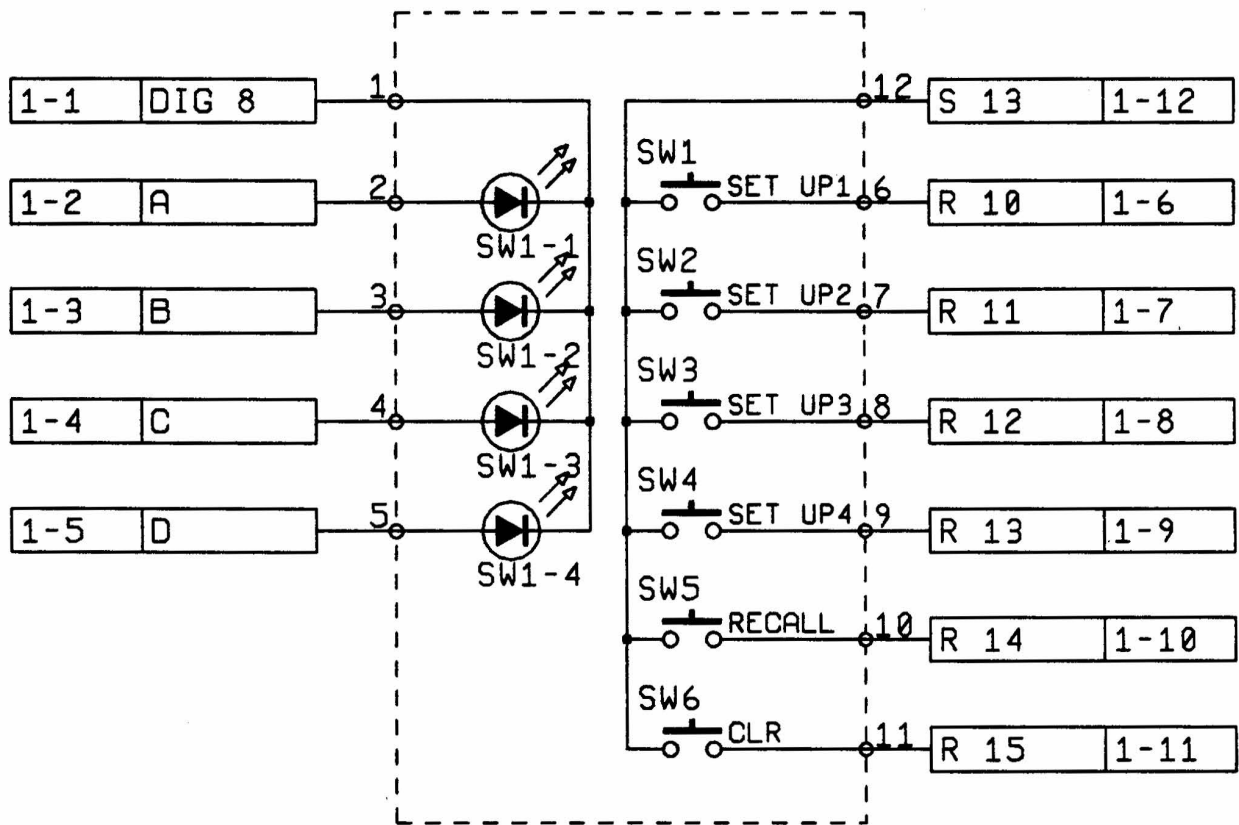

| REF. NO. | OTARI PART NO. | DESCRIPTION |
|----------|----------------|-------------|
| SW       | 1-4            | WH11182Y    |
|          |                | WH0B105C    |
|          | 5              | WH11181     |
|          |                | WH0B104C    |
|          | 6              | WH11181     |
|          |                | WH0B104U    |

C

|          |               |
|----------|---------------|
| NAME     | CH SET UP PCA |
| PART NO. | PB7JD0A       |
| APPLIED  | PB-7JDA       |

4-42943  
DWG. NO.



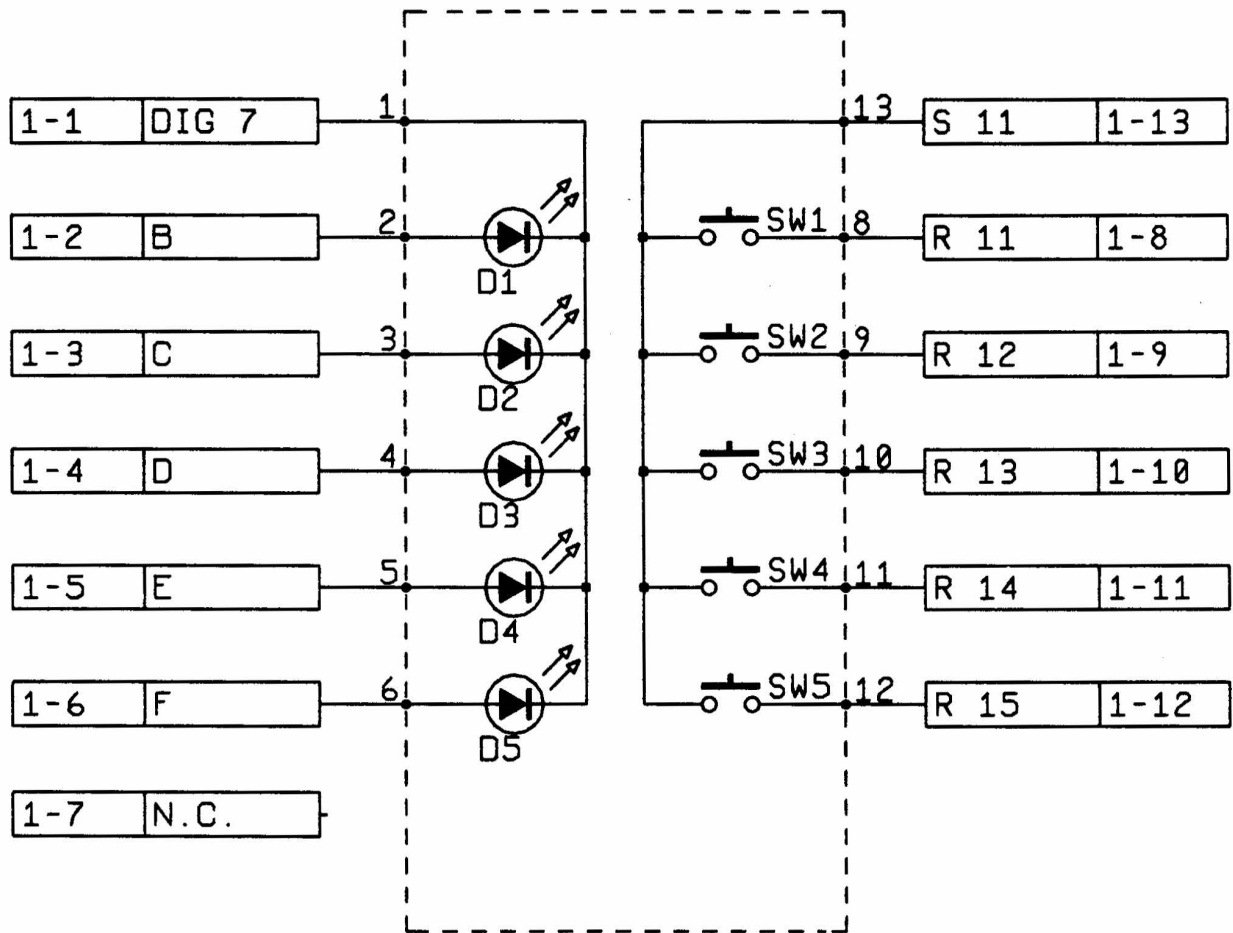

| REF. NO. | OTARI PART NO. | DESCRIPTION      |
|----------|----------------|------------------|
| D        | 1,4            | PNTLG124 TLG124  |
|          | 2              | PNTLY124 TLY124  |
|          | 3,5            | PNTLO124 TLO124  |
| SW       | 1-5            | WH11200B 320E1-1 |

**C**

|         |
|---------|
| 4-42946 |
| NO.     |

|          |               |
|----------|---------------|
| NAME     | MASTER SW PCA |
| PART NO. | PB7JC0A       |
| APPLIED  | PB-7JCA       |