

FS-96 Format & Sample Rate Converter

Operation Manual

TABLE OF CONTENTS

Getting Started	Operating Memories
Welcome to Otari FS-96 4	Using Preset Memories 13
Main Features 4	Recalling Preset Memories 13
Unpacking and Inspection 5	Duplicating Preset Memories 14
Conventions within this Manual 5	Clearing Preset Memories 14
About Digital Audio Formats 5	Using PRESET Keys 15
Controls and Indicators	Setup Mode
Front Panel 6	Operations in Setup Mode 16
Rear Panel 7	Selecting Input Format 17
Installation and Connection	Selecting Reference Clock 18
Installation 8	Configuring Sample Rate Converter 19
Power Supply and Grounding 8	Changing Bit Resolution 20
Connecting Word Clock Signals 8	Activating Dither Function 20
Connecting ADAT Optical Format Signals 9	Editing Status Data 21
Connecting AES/EBU Format Signals 9	Adjusting Sync Timing 22
Connecting SDIF-2 Format Signals 9	Adjusting LCD Contrast 23
Connecting TDIF-1 Format Signals 9	Routing Mode
Basic Operation	Configuring Signal Routing 24
Powering Up 10	BI-DIRECTION MODE
Basic Setup Instructions 10	Using Bi-Direction Mode 25
Operations with LCD 11	SPECIFICATIONS
Modes of Operation 11	FS-96 Specifications 26
Resetting All Settings 12	
Using Key Lock Function 12	
Considering Signal Delay 12	
Mis-synchronization due to Additional Signal Connection 12	



CAUTION

RISK OF ELECTRIC SHOCK
DO NOT OPEN



To prevent fire or shock hazard:

- **Do not remove panels (unless instructed to do so).**
- **There are no user-serviceable parts inside.
Refer servicing to qualified service personnel.**
- **Do not expose this unit to rain or moisture.**



The lightning flash with arrowhead symbol, within an equilateral triangle, is intended to alert the user to the presence of uninsulated “dangerous voltage” within the product’s enclosure that may be of sufficient magnitude to constitute a risk of electric shock to persons.



The exclamation point within an equilateral triangle is intended to alert the user to the presence of important operating and maintenance (servicing) instructions in the the literature accompanying the appliance.

NOTE

This equipment has been tested and found to comply with the limits for a Class B digital device, pursuant to Part 15 of the FCC Rules. These limits are designed to provide reasonable protection against harmful interference in a residential installation. This equipment generates, uses, and can radiate radio frequency energy and, if not installed and used in accordance with the instructions, may cause harmful interference to radio communications. However, there is no guarantee that interference will not occur in a particular installation. If this equipment does cause harmful interference to radio or television reception, which can be determined by turning the equipment off and on, the user is encouraged to try to correct the interference by one or more of the following measures:

- Reorient or relocate the receiving antenna.
- Increase the separation between the equipment and receiver.
- Connect the equipment into an outlet on a circuit different from that to which the receiver is connected.
- Consult the dealer or an experienced radio/TV technician for help.

PLEASE READ THROUGH THE SAFETY INSTRUCTIONS ON THE NEXT PAGE.

Otari FS-96 Format & Sample Rate Converter Operation Manual

Part No. : OS1-132

Copyright © 2000, 2001 by Otari, Inc.

Printed in Japan

This manual may not be reproduced by any means without written permission.

FS-96 and Otari are trademarks of Otari, Inc.

All other trademarks are property of their respective owners.

SAFETY INSTRUCTIONS

- 1. Read Instructions:** All safety and operating instructions should be read before the device is operated.
- 2. Retain Instructions:** The safety and operating instructions should be retained for future reference.
- 3. Heed Warnings:** All warnings on the device and in the operating instructions should be complied with.
- 4. Follow Instructions:** All operating and use instructions should be followed.
- 5. Water and Moisture:** The device should not be used near water — for example, near a bathtub, wash bowl, sink, laundry tub, in a wet basement, near a swimming pool, etc.
- 6. Carts and Stands:** The device should be used only with a cart or stand that is recommended by the manufacturer. A product and cart combination should be moved with care. Quick stops, excessive force, and uneven surfaces may cause the product and cart combination to overturn.

- 7. Ventilation:** The device should be situated so that its location or position does not interfere with its proper ventilation. For example, the device should not be situated on a bed, sofa, rug, or similar surface that may block the ventilation openings; or, placed in a built-in installation, such as a bookcase or cabinet that may impede the flow of air through the ventilation openings.
- 8. Heat:** The device should be situated away from heat sources such as a radiator, heat register, stove or other appliances (including amplifiers) that produce heat.
- 9. Power Sources:** The device should be connected to a power supply only of the type described in the operating instructions or as marked on the device.
- 10. Power Cord Handling:** Handle the power cord by the plug. Do not pull out the plug by tugging the cord and never touch the power cord when your hands are wet as this could cause a short circuit or electric shock. Do not place the unit, a piece of furniture, etc., on the power cord, or pinch the cord. Never make a knot in the cord or tie it with other cords. The power cords should be routed such a way that they are not likely to be stepped on. A damaged power cord can cause a fire or give you an electrical shock. Check the power cord regularly. When you find it damaged, ask your nearest dealer for a replacement.
- 11. Power Cord Protection:** Power supply cords should be routed so that they are not likely to be walked on or pinched by items placed upon or against them, paying particular attention to cords at plugs, convenience receptacles, and the point where they exit from the device.
- 12. Grounding or Polarization:**
 - If this product is equipped with a polarized alternating current line plug (a plug having one blade wider than the other). This plug will fit into the power outlet only one way. This is a safety feature. If you are unable to insert the plug fully into the outlet, try reversing the plug. If the plug should still fail to fit, contact your electrician to replace your obsolete outlet. Do not defeat the safety purpose of the polarized plug.
 - If this product is equipped with a three-wire grounding type plug, a plug having a third (grounding) pin, it will only fit into a grounding type power outlet. This is a safety feature. If you are unable to insert the plug into the outlet, contact your electrician to replace your obsolete outlet. Do not defeat the safety purpose of the grounding type plug.
- 13. Cleaning:** The device should be cleaned only as recommended by the manufacturer.
- 14. Non-Use Periods:** The power cord of the device should be unplugged from the outlet when left unused for a long period of time.
- 15. Object and Liquid Entry:** Care should be taken that objects do not enter and that liquids are not spilled into the enclosure through any openings.
- 16. Damage Requiring Service:** The device should be serviced by qualified service personnel when:
 - a. The power supply cord or the plug has been damaged; or
 - b. Objects have entered, or liquid has been spilled into the appliance; or
 - c. The appliance has been exposed to rain; or
 - d. The appliance does not appear to operate normally or exhibits a marked change in performance; or
 - e. The appliance has been dropped, or the enclosure damaged.
- 17. Servicing:** The user should not attempt to service the device beyond what is described in the operating instructions. All other service should be referred to qualified personnel.

COMMUNICATION WITH OTARI

FOR SERVICE INFORMATION AND PARTS

All Otari products are manufactured under strict quality control. Each unit is carefully inspected and tested prior to shipment. If, however, some adjustment or technical support becomes necessary, replacement parts are required, or technical questions arise, please contact your Otari dealer or contact Otari at:

Otari, Inc.

4-33-3 Kokuryo-cho
Chofu-shi, Tokyo 182 Japan
Phone : +81/42481-8626
Fax : +81/42481-8633
URL : www.otari.co.jp

Otari Corporation

8236 Remmet Avenue
Canoga Park, California 91304 U.S.A.
Phone : +1/818-598-1200
Fax : +1/818-594-7208
URL : www.otari.com

Otari Europe GmbH

Rudolf-Diesel-Strasse 12
D-40670 Meerbusch, Germany
Phone : +49/2159-50861
Fax : +49/2159-1778

Otari Singapore Pte., Ltd.

701 Sims Drive #02-02 LHK Building
Singapore 387383
Phone : +65/846-1553
Fax : +65/846-7875

Another part of Otari's continuing technical support program for our products is the continuous revision of manuals as the equipment is improved or modified. In order for you to receive the information and support which is applicable to your equipment, and for the technical support program to function properly, please include the following information, most of which can be obtained from the Serial number label on the machine, in all correspondence with Otari:

- Model Number:
- Serial Number:
- Date of Purchase:
- Name and address of the dealer where the machine was purchased and the power requirements (voltage and frequency) of the machine.

Getting Started

Welcome to Otari FS-96

Congratulations on your purchase of the Otari FS-96!

The Otari FS-96 is a device for converting signal formats and sample rates of digital audio signals. A total of five professional digital audio formats (ADAT, AES/EBU, SDIF-2, TDIF-1, OPTION) are supported and 24 channels of digital audio signals can be converted simultaneously to all of the signal formats available on the FS-96, at the desired sample rate.

In addition to the format and sample rate conversion capabilities, the FS-96 can be used as a digital signal router and the connections between the input and output channels can be changed internally without changing any physical connections.

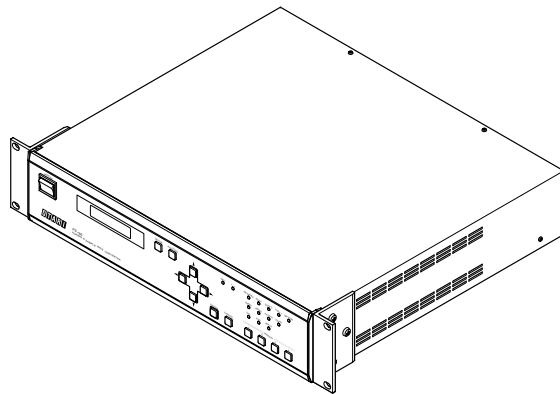

Main Features

■ **Five Digital Audio Formats:** The FS-96 supports five digital audio formats (ADAT, AES/EBU, SDIF-2, TDIF-1, OPTION). The digital audio signals input in any of these formats can be output in all of the formats available on the FS-96.

■ **24-channel Capacity with Signal Routing Function:** The FS-96 can handle 24 channels of audio inputs at the same time. By using the signal routing function, the connections between the input and output channels can be changed internally without changing any physical connections.

■ **96 kHz Sample Rate & 24-bit Quantization:** The FS-96 supports sample rates of 32 kHz to 96 kHz and bit resolution of 16 to 24 bit. By using the internal sample rate converters, the sample rate and bit resolution of the input audio can be changed as desired.

■ **Same Format Sample Rate Conversion:** Whenever audio is input in a given format, the output for that same format is also available, and it can be sample rate converted to the same output format if needed.

■ **Accurate Clock Generation Circuit:** The FS-96 is equipped with an accurate clock generation circuit for achieving signal accuracy at professional level. Even unstable digital inputs can be regenerated as accurate outputs.

■ **Preset Memories for Operation and Routing Settings:** A maximum of 10 preset memories can be used for storing each of operation and routing settings. Furthermore, combinations of operation and routing memories can be stored into four PRESET keys and they can be recalled by merely pressing a PRESET key.

■ **Various Signal Synchronization:** The output audio can be synchronized to any of three signals — FS-96's internal clock signal, external Word Clock signal, and the input audio signal.

■ **Linking Multiple Units with Sample Accuracy:** Multiple FS-96 units can be synchronized with phase-level sample accuracy by linking the units using Word Clock signals.

■ **Bi-directional Conversion with TDIF and AES/EBU:** Simultaneous bi-directional signal format conversions are possible between the TDIF-1 and AES/EBU interfaces. This mode is provided especially for digital recorders having the TDIF-1 interfaces.

■ **Status Data Editing Function:** It is possible to edit the status data contained in each of the digital audio formats.

■ **Expansion with Option Slots:** An option slot is provided on the rear panel to accept a new digital audio format by inserting an expansion module.

■ **Comprehensive Operations with LCD:** All system configurations are done in menu-driven screens via the LCD.

■ **19" Standard Rack:** Each FS-96 includes a set of adapters for installing into a standard 19-inch rack. The FS-96 occupies only a 2U rack space.

■ **Universal Power Supply Included:** The FS-96 is equipped with a universal power supply circuit which supports AC voltages and frequencies used all over the world.

Getting Started

Unpacking and Inspection

■ **Unpacking:** Each FS-96 is carefully packed and shipped to avoid damage during transportation. We recommend that you open the carton carefully and retain the packing materials at least until proper operation of the machine has been established.

■ **Visual Inspection:** After unpacking, inspect the FS-96 visually. If there is any evidence of damage due to rough handling during shipping, you must notify the transportation carrier and submit a claim. Do not connect or use the FS-96 if damage is found.

■ **Confirmation of Standard Accessories:** Check that the carton contains the following standard accessories:

PART NAME	PART NO.	Q'TY	DESCRIPTION
FOOT	CY4176--	4	PRE-INSTALLED
RACK MOUNT ADAPTER	KZ2Z222-	2	PRE-INSTALLED
FUSE (3.15 A, 250 V)	FH9-020	1	
POWER SUPPLY CORD	PZ9D003-	1	
OPERATION MANUAL	OS1-132-	1	THIS BOOKLET *

Conventions within this Manual

■ **Machine Names:** When describing a FS-96, we use the terms "FS-96" or simply "unit".

■ **Upper Case:** We use all upper case type to describe a button or control when that item is similarly labeled on the machine (e.g., POWER switch). Machine status or operating modes are described with an upper case first letter.

About Digital Audio Formats

The FS-96 can handle the following five digital audio formats:

■ **AES/EBU (AES3) Format:** This format was standardized by the AES [Audio Engineering Society] and EBU [European Broadcasting Union] jointly. The signals consist of 2-channel stereo pairs and are connected with cables having 110 Ω impedance. The FS-96 uses three 25-pin D-sub connectors for both inputs and outputs and each of the connectors can handle 8 channels (4 stereo pairs) of digital audio.

■ **ADAT Optical [Alesis multi-channel optical digital interface] Format:** This format was developed by Alesis especially for ADAT recorders and is referred to as "Alesis Lightpipe". A dedicated optic fiber cable is used for connecting 8 channels of digital audio. The FS-96 provides three systems of ADAT interfaces for handling a total of 24 channels.

■ **SDIF [Sony Digital InterFace] Format:** This format was developed by Sony for handling 24 channels of digital audio. A 50-pin D-sub connector is used for connecting the 24 channels simultaneously. A Word Clock signal is needed as a synchronization signal. This format is also referred to as "DASH" format.

■ **TDIF [Tascam Digital InterFace] Format:** This format was developed by Tascam and uses a 25-pin D-sub connector for both inputs and outputs 8 channels of digital audio signals. The signals consist of 4 systems of 2-channel multiplexed pairs. The FS-96 uses three 25-pin D-sub connectors for handling a total of 24 channels.

■ **MADI [Multi-channel Audio Digital Interface] Format (Optional):** This format was standardized by AES [Audio Engineering Society] for transmitting multi-channel digital audio signals. This format is mainly used as an audio interface for digital mixing consoles and a maximum of 56 channels of audio can be transmitted with one coaxial cable. The FS-96 can handle a maximum of 24 channels of MADI signals, by installing the optional MADI expansion module [ZA-9CF-S] into the option slot.



The current MADI format does not support signals having a sample rate higher than 48 kHz.



The FS-96 supports signals of up to 24-bit and 96 kHz in all of the above four formats. However, the 96 kHz signals are not supported officially in the formats other than AES/EBU. Thus, please be aware that Otari does not guarantee the performance of the 96 kHz signals in these formats.

Controls and Indicators

Front Panel

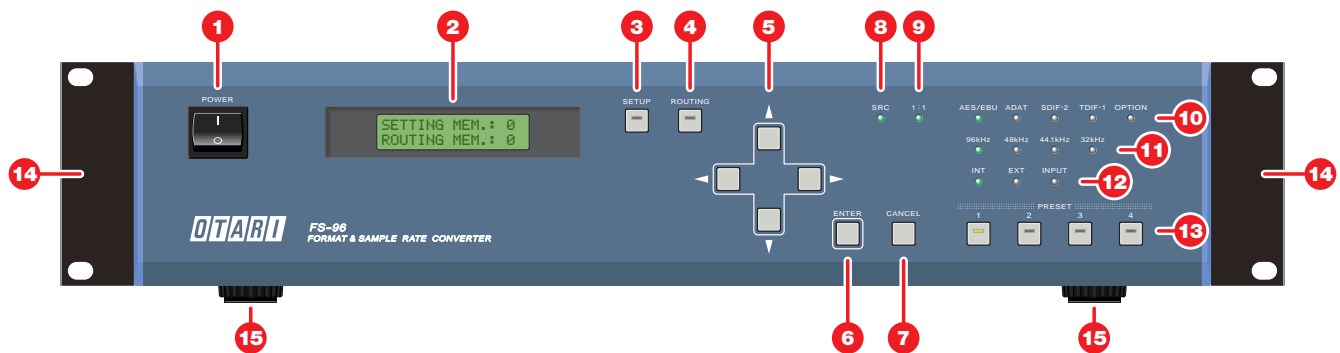

[1] POWER switch

Used to power up and shut down the unit. Press the “I” side to turn the unit on and press the “O” side to turn it off.

[2] LCD (Liquid Crystal Display)

Displays various system settings and signal routing configurations with a 16-character x 2-line display. A back-light mechanism is provided.

[3] SETUP key

Used to put the FS-96 into Setup mode for making operation settings. When the SETUP key is pressed, the key’s LED illuminates and the FS-96 enters Setup mode. In this mode, various system settings excluding routing configuration can be made via the LCD. Up to 10 sets of parameter values can be stored into the setting memories.

[4] ROUTING key

Used to put the FS-96 into Routing mode for making signal routing configurations. When the ROUTING key is pressed, the key’s LED illuminates and the FS-96 enters Routing mode. In this mode, internal connections of the input and output channels can be changed via the LCD. Up to 10 signal routing settings can be stored into the routing memories.

[5] Arrow keys

Used to change the LCD screen, or to move the cursor on the screen. When a parameter is selected on the LCD, these keys are used to change the parameter value.

[6] ENTER key

Used to select a parameter value on the LCD screen, or to store a parameter value.

[7] CANCEL key

Used to stop the entry of parameter values, or to return the screen to the previous one.

[8] SRC [Sample Rate Converter] indicator

Illuminates when the sample rate converter is turned on. If the sample rate converter does not operate properly, this indicator flashes.

[9] 1 : 1 indicator

Illuminates when the signal routing is OFF. When this indicator is lit, the input channels are connected to the same output channels.

[10] Source indicators

(AES/EBU, ADAT, SDIF-2, TDIF-1, OPTION)

Display the selection of the input format. If no signal is present or synchronization to the input signal cannot be obtained, the indicator for the selected format will flash.

[11] Sample Rate indicators

(96 kHz, 48 kHz, 44.1 kHz, 32 kHz)

Display the sample rate of the output signals. Note that each indicator will illuminate when the sample rate is within a range of $\pm 1\%$ of the indicated frequency. Both the 32 kHz and 44.1 kHz indicators are lit for the 64 kHz sample rate. Also, both the 44.1 kHz and 48 kHz indicators are lit for the 88.2 kHz sample rate.

[12] Reference Clock indicators (INT, EXT, INPUT)

Display the selection of the reference clock for the output signals — INT = FS-96’s internal clock signal, EXT = external Word Clock signal, INPUT = input audio signal. When the EXT or INPUT is selected, the indicator for the selected signal will flash, if no signal is present or if the synchronization cannot be achieved with the input signal.

[13] PRESET keys 1 – 4

Used to store combinations of setting and routing memories. When a PRESET key is pressed, the stored combination will be recalled and the system configurations will be changed momentarily. The key’s indicator illuminates when the stored combination is being used.

[14] Rack mount adapters

Used to install the FS-96 into a standard 19-inch rack. The adapters can be removed if they are not necessary.

[15] Feet

If the FS-96 is to be installed in a standard 19-inch rack, remove the feet.

Controls and Indicators

Rear Panel

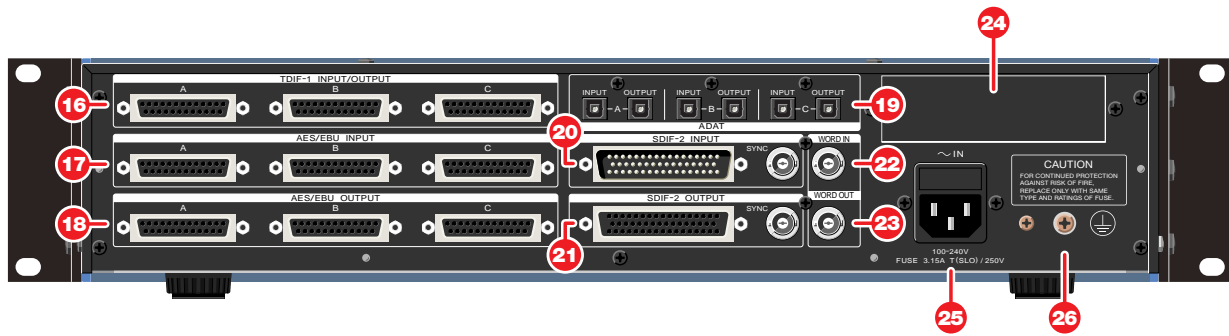

[16] TDIF-1 INPUT/OUTPUT connectors A – C

Used to connect the TDIF-1 signals. The 8 channels of both inputs and outputs are aligned in a single connector and the FS-96 uses three 25-pin D-sub connectors (A – C) for handling a total of 24 channels.

[17] AES/EBU INPUT connectors A – C

[18] AES/EBU OUTPUT connectors A – C

Used to connect the AES/EBU (AES3) signals. Each connector handles 8 channels of audio (2-channel stereo pair x 4) and the FS-96 can handle a total of 24 channels of AES/EBU signals with three connectors A – C.

[19] ADAT INPUT & OUTPUT connectors A – C

Used to connect the ADAT optical signals. Connections are made with dedicated optic fiber cables and 8 channels of audio can be connected with a single cable. The FS-96 provides three systems of ADAT interfaces for handling a total of 24 channels.

[20] SDIF-2 INPUT connector & SYNC connector

[21] SDIF-2 OUTPUT connector & SYNC connector

Used to connect the SDIF-2 signals. A single 50-pin D-sub connector (input = male, output = female) is used for connecting the 24 channels simultaneously. Since the SDIF-2 format requires a Word Clock signal for synchronization, a SYNC connector (BNC type) is provided for each of input and output connector.

[22] WORD IN connector

Used to connect an external Word Clock signal which is to be used as the reference clock signal for the output audio signals.

[23] WORD OUT connector

Used to output the reference clock for the output signals as a Word Clock signal to external devices.

[24] Option Slot

An expansion slot for adding a new digital audio format to the FS-96.

[25] AC IN connector

Used to connect the AC power supply to the unit. The fuse holder is contained in the AC inlet. The power supply circuit of the FS-96 supports AC voltages and frequencies used all over the world.

[26] Auxiliary Ground Terminal

Auxiliary ground terminal for the power supply circuit. Use this terminal when the proper grounding cannot be made with the AC inlet.

Installation and Connection

Installation

■ **Location for Installation:** Choose a well ventilated location for installing the FS-96. Do not place the unit in a closed rack or closed boxes. Although the unit is designed to be used in various temperature environments, be sure to place it away from heat sources such as heaters, power amplifiers, etc.



NOTES ON OPERATING LOCATION:

- Do not cover the ventilation slots of the unit.
- To prevent damage or short-circuiting of the internal electronic parts, do not install the rack in a place where the rack would be subject to rain, snow, or spills, etc.
- To prevent overheating, do not expose the unit directly to the sun.
- When installed in a rack, place the rack at a level and stable location.

■ **Rack/Flight Case Mounting:** When mounting the unit in a rack, remove feet on the bottom panel. Then use the provided rack mount adapters [KZ2A222-] to mount the FS-96 in the rack. When securing the unit, we recommend to insert a plastic washer between the screw and the rack mount adapters to prevent scarring.

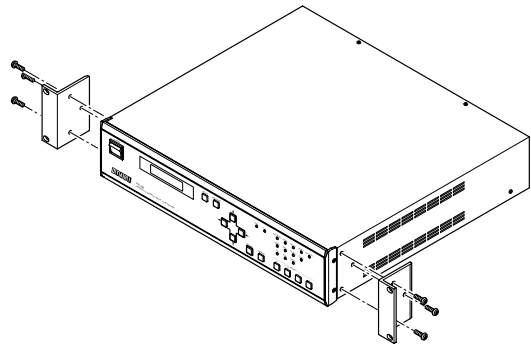

NOTES:

- The rack mount adapters are pre-installed before shipping.
- The FS-96 occupies a 2U rack space.

Power Supply and Grounding

■ **Connecting AC Power:** Use the provided power supply cord and connect the AC IN connector to the AC mains. The FS-96 is equipped with a universal power supply circuit which supports AC voltages (100 – 240 V) and frequencies (50 / 60 Hz) used all over the world.

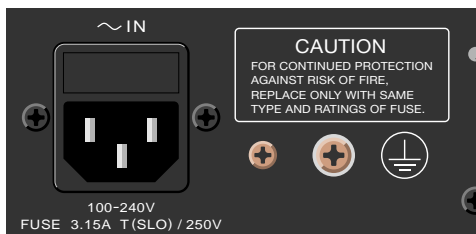

CAUTION! To prevent damage to the FS-96 and the connected equipment, do not connect or disconnect the cables while the machines are turned on.

■ **Grounding:** The FS-96 has an auxiliary ground terminal for the power supply circuit. If no ground terminal exists on the AC mains, use the ground terminal for proper grounding.



CAUTION! If the machine is not properly grounded, a high voltage may appear on the chassis if a short circuit should occur.

NOTE: Confirm that lightning protection equipment is used in the power supply system of your facility. Also, we recommend to use a noise filter in the AC mains which is used to provide AC power to the FS-96, in order to prevent the FS-96 internal circuit from being damaged by AC line noise, high voltage spikes, surges, and “brown outs”.

Connecting Word Clock Signals

■ Connection of Word Clock Signals:

The FS-96 is equipped with BNC connectors for interfacing the Word Clock signals. The FS-96 uses the Word Clock signals for synchronizing with an external device. Connect a coaxial cable of 75 Ω impedance to the WORD IN or WORD OUT connector for interfacing the Word Clock signals.



■ **Performing External Synchronization:** To synchronize the output audio signals to the input Word Clock signal, select “WORD” as the reference lock of the FS-96 in the OUTPUT SYNC screen in Setup mode (see p.18).

NOTE: The reference clock for the output signals is output from the WORD OUT connector. If the external Word Clock signal is used as the reference clock, a signal synchronized to the external Word Clock signal will be output from the WORD OUT connector. Note that the WORD OUT connector cannot be used as a “through-out” connector.

Installation and Connection

Connecting ADAT Optical Format Signals

The ADAT optical format uses an optical cable for connecting 8 channels of audio. The FS-96 has three connectors (A – C) for both input and output to handle a total of 24 channels of ADAT signals. Each connector corresponds to the following channels — A = CH1 – 8, B = CH9 – 16, C = CH17 – 24.

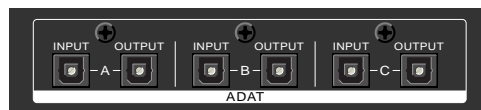

Connecting AES/EBU Format Signals

The AES/EBU format uses a D-sub 25-pin female connector for connecting 8 channels of audio. The FS-96 has three connectors (A – C) for both input and output to handle a total of 24 channels of AES/EBU signals. Each connector corresponds to the following channels — A = CH1 – 8, B = CH9 – 16, C = CH17 – 24. The 8 channels of audio consist of four stereo pairs.

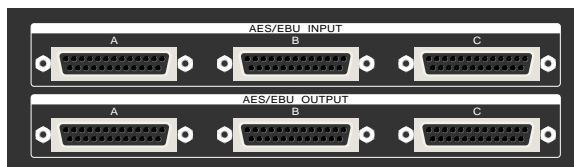

NOTES:

- Use a cable of 110 Ω impedance for connecting the AES/EBU signals.
- Some manufacturers use different pin assignments for the AES/EBU connectors. Before connecting, please check for the pin assignment which is used on the device to be connected.

Pin Assignment:

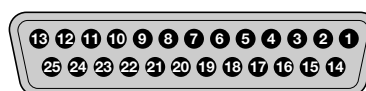

1–6, 13–19 : NC

CH	PIN		
	HOT	COLD	GND
1 / 2	24	12	25
3 / 4	10	23	11
5 / 6	21	9	22
7 / 8	7	20	8

Connecting SDIF-2 Format Signals

The SDIF-2 format uses a single D-sub 50-pin connector (input : male, output : female) for connecting a maximum of 24 channels of audio. Note that the Word Clock signal needs to be connected via the BNC connector for synchronization.

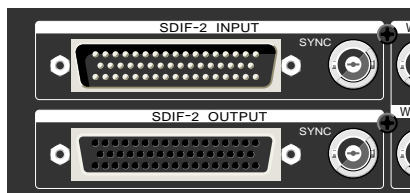

Pin Assignment:

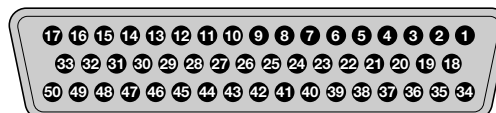

PIN	SIGNAL	PIN	SIGNAL	PIN	SIGNAL	PIN	SIGNAL	PIN	SIGNAL
1	CH1 (-)	11	CH6 (-)	21	CH11 (-)	31	CH16 (-)	41	CH21 (-)
2	CH1 (+)	12	CH6 (+)	22	CH11 (+)	32	CH16 (+)	42	CH21 (+)
3	CH2 (-)	13	CH7 (-)	23	CH12 (-)	33	CH17 (-)	43	CH22 (-)
4	CH2 (+)	14	CH7 (+)	24	CH12 (+)	34	CH17 (+)	44	CH22 (+)
5	CH3 (-)	15	CH8 (-)	25	CH13 (-)	35	CH18 (-)	45	CH23 (-)
6	CH3 (+)	16	CH8 (+)	26	CH13 (+)	36	CH18 (+)	46	CH23 (+)
7	CH4 (-)	17	CH9 (-)	27	CH14 (-)	37	CH19 (-)	47	CH24 (-)
8	CH4 (+)	18	CH9 (+)	28	CH14 (+)	38	CH19 (+)	48	CH24 (+)
9	CH5 (-)	19	CH10 (-)	29	CH15 (-)	39	CH20 (-)	49	N.C.
10	CH5 (+)	20	CH10 (+)	30	CH15 (+)	40	CH20 (+)	50	N.C.

Connecting TDIF-1 Format Signals

The TDIF-1 format uses a D-sub 25-pin female connector for connecting 8 channels of both inputs and outputs. The FS-96 has three connectors (A – C) for the TDIF-1 interface to handle a total of 24 channels of audio. Each connector corresponds to the following channels — A = CH1 – 8, B = CH9 – 16, C = CH17 – 24. The 8 channels of audio consist of four multiplexed pairs.

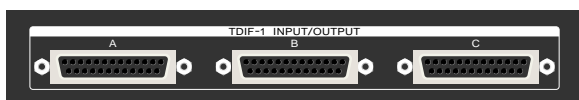

Pin Assignment:

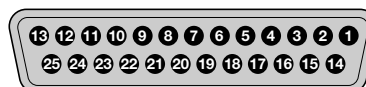

PIN	SIGNAL	PIN	SIGNAL	PIN	SIGNAL
1	DOUT 1 / 2	10	DIN 7 / 8	19	FS 1 OUT
2	DOUT 3 / 4	11	DIN 5 / 6	20	FS 1 IN
3	DOUT 5 / 6	12	DIN 3 / 4	21	EMPH. IN
4	DOUT 7 / 8	13	DIN 1 / 2	22	GND
5	LRCK OUT	14	GND	23	GND
6	FS 0 OUT	15	GND	24	GND
7	GND	16	GND	25	GND
8	FS 0 IN	17	GND		
9	LRCK IN	18	EMPH. OUT		

Powering Up

■ **Starting Signal Conversion:** To turn on the power to the unit, press the upper part (marked "I") of the POWER switch located on the front panel.



When the power is applied, all indicators are lit for about 3 seconds and the LCD shows the start-up screen. Then, the initial screen appears on the LCD and the FS-96 starts to operate. Note that the FS-96 always stores the current operation settings and the signal conversion automatically starts with the preset configurations which were last used.

NOTE — Using FS-96 as a Turn-key System: If the connections and configurations are properly made, the FS-96 can be started up by merely turning on the system. This means that the system can be used as a turn-key system.

■ **Display of Initial Screen:** On the initial screen of the LCD, you can check for the numbers of the preset memories which are currently being used. The FS-96 operates according to the settings stored in the setting and routing memories. By pressing the upper & lower Arrow keys, you can change the LCD screen as follows. In another page of the initial screen, you can check for the information for the input and output signals.

■ INITIAL SCREENS:

```
SETTING MEM.: 0 ← SETTING MEMORY No.
ROUTING MEM.: 0 ← ROUTING MEMORY No.
```

(USE [] [] TO CHANGE SCREENS)

```
FI: 1/2 -----K ← INFO. FOR INPUTS
FO: 1/2 96.00K ← INFO. FOR OUTPUTS
```

(USE [] [] TO CHANGE DISPLAY RANGE)

Basic Setup Instructions

1. Press **SETUP** Button, to access menu items below.
2. Select **INPUT FORMAT (ADAT, AES, BDIR, TDIF, SDIF, OPTION)**.
 - **Channel Grouping:** All digital formats above are grouped in 8 channel groups except for SDIF-2 which is grouped in a single 24 channel group on a 50-pin connector (Group A: 1–8, Group B: 9–16, Group C: 17–24).
 - **Imbedded Sync Signal:** Clocks (sync) for ADAT, AES, BDIR, and TDIF are imbedded in the audio bitstreams for their respective formats.
 - **SDIF-2 Synchronization:** For synchronizing SDIF-2, use the SYNC BNC connectors on the rear panel of the FS-96 (SYNC Input or SYNC Output), located to the right of the 50 pin SDIF-2 connectors.
3. Select **OUTPUT SYNC (<INTERNAL>, EXTERNAL, INPUT)**.
 - **BNC Sync connectors:** The Word Clock IN and OUT BNC connectors are for OUTPUT SYNC only.
 - **If OUTPUT SYNC = INTERNAL**
 - Select FS SETTING (sample rate = 32K, 44.1K, <48K>, 64K, 88K, 96K)
 - **If OUTPUT SYNC = INPUT**
 - If Input Format = AES (Select Sync Group choice: <CH1/2>, CH3/4, or CH5/6...CH23/24)
 - If Input Format = ADAT, TDIF, BDIR (Select Sync Group choice: <GRPA>, GRPB, or GRPC)
4. Select **SAMPLE RATE CONVERT <ON>**, for sample rate conversion.
5. Select **OUTPUT RESOLUTION (16BITS, 20BITS, <24BITS>)**.

The FS-96 automatically detects the bit resolution of the input signals. Normally, the bit resolution of the input signals is selected in this screen.
6. Select **DITHER as required (ON, <OFF>)**.

This is usually used for down-conversion of sample rates (such as down-converting from 48k to 44.1k).
7. Set **OUTPUT STATUS as required**.

The following settings are possible.

 - AES/EBU EMPH.: OFF, THRU, 5010, CCIT)
 - AES/EBU FREQ.: THRU, 32K, 44K, 48K, AUTO
 - SDIF EMPH.: THRU, ON, OFF
 - TDIF EMPH.: THRU, ON, OFF
 - TDIF BIT RES.: THRU, 16, 20, 24
 - TDIF FREQ.: THRU, 32K, 44K, 48K, OTHER
8. Set **SYNC TIMING as required for digital lock**.
 - INPUT DELAY A, B, or C (-2, -1, 0, +1, +2) to adjust clock reference
 - TDIF OUTPHASE: 0 (-2, -1, 0, +1, +2) to adjust LRCK framing.

Basic Operation

Operations with LCD

■ **Basic Operations:** The operation of the FS-96 is controlled by the parameters set on the LCD. The procedure for setting parameters is fully menu-driven and the selection is made with the Arrow keys, in conjunction with the ENTER and CANCEL keys.

□ **Changing LCD Screens:** Each mode consists of multiple LCD screens and the screens can be changed by pressing the upper & lower Arrow keys. When a screen is displayed, press the ENTER key to select a parameter on the screen. To release the selection, press the CANCEL key.

□ **Changing Parameter Values:** When a parameter is selected, the value for that parameter is displayed with parentheses (< >). At this point, you can change the parameter value by pressing the right & left Arrow keys. If many choices are available for that parameter, use the upper & lower Arrow keys to change the value in larger increments. After the desired value is entered, press the ENTER key again to store the value into the current memory and to reflect the setting onto the actual operation.

NOTE: The actual operation is changed by altering the internal circuit configurations. It may take a few seconds until the settings are reflected onto the actual operation.

■ **Cancelling Parameter Changes:** If a parameter does not need to be changed, you can return the parameter value by pressing the CANCEL key. When the CANCEL key is pressed, the parameter selection is released and the parameter value will be returned to the status when the ENTER key is last pressed. Note that, if a value is already stored by pressing the ENTER key, that value cannot be returned to the previous value.

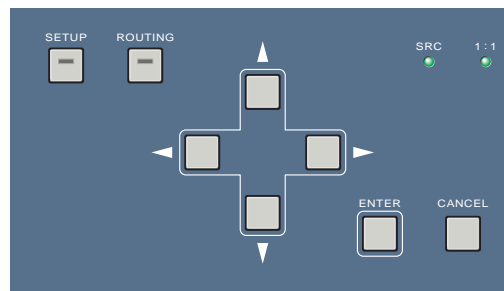

NOTE: The configuration modes (Setup and Routing modes) cannot be released when a parameter is selected in a setting screen. Press the CANCEL (or ENTER) key to release the selection and then press the SETUP or ROUTING key to leave the configuration mode.

Modes of Operation

■ **Operation Modes:** The FS-96 operates in either of the following two conversion modes.

□ **Normal Mode:** This mode is used to convert the format and sample rate of the 24 channels of digital audio. The input digital audio signals will be converted to all of the signal formats available on the FS-96. When the FS-96 is in Normal mode, all advanced functions are available such as the sample rate conversion, change of bit resolution, signal routing, etc.

□ **Bi-Direction Mode (⇨ p.25):** This mode is used to perform the bi-directional format conversions between the TDIF-1 and AES/EBU interfaces. Bi-Direction mode is prepared for situations such as connecting a digital audio recorder having a TDIF-1 interface with a digital mixing console having an AES/EBU interface. In this mode, the advanced functions such as sample rate conversion or signal routings are not available.

Selection of the operation mode is made by changing the input format. If the input format is set to "BDIR", the FS-96 is set to Bi-Direction mode. If the input format is set to a format other than "BDIR", the FS-96 is placed in Normal mode.

NOTE: The FS-96 operates according to the settings stored in the preset memories. The FS-96 always stores current preset memory numbers when the power is turned off and the same memory numbers are used when the power is turned back on.

■ **Configuration Modes:** The operation settings are made in two configuration modes — Setup and Routing modes.

□ **Setup Mode (⇨ p.16–23):** The system settings excluding the routing settings are made in Setup mode. To place the FS-96 into Setup mode, press the SETUP key on the front panel so that the key's indicator illuminates. Pressing the SETUP key again causes the key's indicator to go off and the FS-96 to leave Setup mode.

□ **Routing Mode (⇨ p.24):** Routing mode is used only for configuring signal routing settings. To place the FS-96 into Routing mode, press the ROUTING key on the front panel so that the key's indicator illuminates. Pressing the ROUTING key again causes the key's indicator to go off and the FS-96 to leave Routing mode.

NOTE: The operation settings can be stored into 10 preset memories and the preset settings can be used by recalling the memories. Please refer to the "Operating Memories" section for the details of preset memories (⇨ p.13–15). Also, combinations of setting and routing memories can be stored to the PRESET keys on the front panel. Please refer to the "Using PRESET Keys" section for the usage of the PRESET keys (⇨ p.15).

Basic Operation

Resetting All Settings

All parameters can be reset to the factory settings by initializing the system memory of the FS-96. To initialize the system memory, hold the CANCEL key pressed and turn on the power to the FS-96. The following screen appears for about 5 seconds to indicate that all settings are reset to the default values.

■ RESET SCREEN



ALL SETTINGS ARE
RESET TO DEFAULT

After the system memory is initialized, the following screen appears after powering up to indicate that no setting data is present on the system memory.

■ NO SETTING DATA ON MEMORY



NOTE:
NO SETTING DATA

NOTE — Replacing Backup Battery: If the above screen appears every time the power is turned on and the stored settings are lost, the backup memory may be dead. In this case, please contact your Otari dealer for replacement of backup batteries.

Using Key Lock Function

To avoid accidental changes in the system settings, the operations of the FS-96 can be locked by holding the ENTER key down in the initial screen. The following appears when the operation is locked.

■ KEY LOCK SCREEN



KEY LOCKED. HOLD
ENTER TO RELEASE

To release the key lock, simply hold the ENTER key pressed until the LCD shows the initial screen.

Considering Signal Delay

Since the FS-96 handles all audio signals in digital fields, please be aware that some delay is applied to all signals by passing through the FS-96. Although the amount of signal delay varies due to the signal formats, normally the delay between the input and output will be 2 to 3 samples.

Mis-synchronization due to Additional Signal Connection

If a signal cable is additionally connected to the current input format, or if all connectors are disconnected and then re-connected, the phase-level synchronization of the input signals will be lost. In this case, the following screen appears on the LCD to alert the operator, since the signal synchronization cannot be obtained on the destination machines, even if there are no audible problems. When this screen is displayed, press the ENTER key to reset the synchronization circuit and to return to the proper operation status.

■ PHASE ERROR SCREEN



PHASE ERROR
RESET FS-96?<OK>



Operating Memories

Using Preset Memories

■ **Setting and Routing Memories:** The FS-96 has two configuration modes consisting of Setup mode and Routing mode, and the preset memories are provided for each of the configuration modes — setting memories and routing memories. All system settings for the FS-96 are stored in these preset memories. The setting memories are used to store the operation settings made in Setup mode, excluding the signal routing configurations. Also, the routing memories are used only to store the signal routing settings made in Routing mode.

10 preset memories (No. 0 – 9) are provided for each of the configuration modes and the operation settings can be altered momentarily by changing the memory number selections. Since the setting and routing memories can be selected separately, it is possible to change the signal routing settings while the same operation settings are maintained. Also, it is possible to change the system settings while the same routing settings are maintained.

NOTE: Combinations of setting and routing memories can be stored to the PRESET keys on the front panel. Please refer to the “Using PRESET Keys” section for the usage of the PRESET keys (⇨ p.15).

■ **Display of Current Preset Memories:** The initial screen displays the preset memory numbers that are currently used. Note that the changes made in the configuration modes will be stored into the preset memories which are currently used. When changing the operation parameters, confirm that the desired memory numbers are displayed on the initial screen. See the “Recalling Preset Memories” section on this page for the details of recalling preset memories.

■ INITIAL SCREENS:



← SETTING MEMORY No.
← ROUTING MEMORY No.

NOTE: The contents of the preset memories will be updated every time a parameter value is stored. It is recommended to copy the memory contents before making large changes to the various settings.

Recalling Preset Memories

To change the preset memories to be used, follow the instructions below to recall the desired memory numbers.

1. Press the ENTER key in the initial screen and select the number of setting or routing memories.

The setting memory number is displayed with parentheses. To select the routing memory number, press the Upper or Lower Arrow keys.

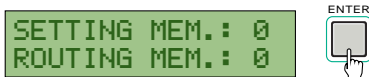

SETTING MEM.: 0
ROUTING MEM.: 0

■ SELECTING SETTING MEMORY

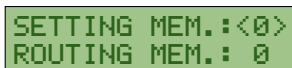

SETTING MEM.: <0>
ROUTING MEM.: 0

(USE ▲ ▼ TO MOVE SELECTION)

■ SELECTING ROUTING MEMORY



SETTING MEM.: 0
ROUTING MEM.: <0>

(USE ▲ ▼ TO MOVE SELECTION)

2. Use the right & left Arrow keys to select the desired memory number and press the ENTER key to store.



SETTING MEM.: <1>
ROUTING MEM.: 0

(USE ◀ ▶ TO CHANGE MEMORY NUMBER)



WAIT A MOMENT...

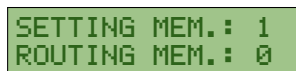

SETTING MEM.: 1
ROUTING MEM.: 0

It may take a few seconds until the settings are changed and the LCD shows “WAIT A MOMENT...” during this time.

Operating Memories

Duplicating Preset Memories

The contents of each preset memory can be duplicated into the other memory numbers. This function is useful when you make important changes, or when it becomes necessary to prepare two or more similar settings.

1. Press the **ENTER** key in the initial screen and select the setting or routing memory number.

```
SETTING MEM.: 0
ROUTING MEM.: 0
```



```
SETTING MEM.: <0>
ROUTING MEM.: 0
```

(USE   TO MOVE SELECTION)

2. Hold the **ENTER** key pressed until the following screen appears on the LCD. Then, use the right & left Arrow keys to select the destination memory number to which the contents of the current memory number will be copied.

■ COPYING SETTING MEMORY

```
SETTING COPY:
0 => < 1 >
```

(USE   TO CHANGE MEMORY NUMBER)

■ COPYING ROUTING MEMORY

```
ROUTING COPY:
0 => < 1 >
```

(USE   TO CHANGE MEMORY NUMBER)

3. Press the **ENTER** key to store the destination memory number.

The contents of the current memory number are copied to the destination memory number.

The LCD returns to the initial screen, with the destination memory number selected.

```
SETTING MEM.: <1>
ROUTING MEM.: 0
```

4. To use the destination memory number, press the **ENTER** key to release the memory number selection.

```
SETTING MEM.: 1
ROUTING MEM.: 0
```

Clearing Preset Memories

The contents of each memory number can be cleared in the following manner.

1. Press the **ENTER** key in the initial screen and select the setting or routing memory number.

```
SETTING MEM.: 0
ROUTING MEM.: 0
```



```
SETTING MEM.: <0>
ROUTING MEM.: 0
```

(USE   TO MOVE SELECTION)

2. Hold the **CANCEL** key pressed until the following screen appears on the LCD.

■ RESETTING SETTING MEMORY

```
RESET MEM. 0 TO
DEFAULT? <YES> NO
```

(USE   TO SELECT YES OR NO)

■ RESETTING ROUTING MEMORY

```
RESET MEM. 0 TO
1:1? <YES> NO
```

(USE   TO SELECT YES OR NO)

3. To clear the contents of the selected memory number, select **"YES"** and press the **ENTER** key.

The following screen appears for about one second. Then, the LCD returns to the initial screen, with the memory number selected.

■ RESETTING SETTING MEMORY

```
SETTING RESET
...DONE.
```

■ RESETTING ROUTING MEMORY

```
ROUTING RESET
...DONE.
```

```
SETTING MEM.: <0>
ROUTING MEM.: 0
```

4. If the reset memory number is to be used, press the **ENTER** key to store the memory number selection.

The selection of the memory number will be released.

```
SETTING MEM.: 0
ROUTING MEM.: 0
```

Operating Memories

Using PRESET Keys

■ **About PRESET Keys:** The four PRESET keys on the front panel are used to store combinations of setting and routing memory numbers. Once a memory combination is stored in a PRESET key, both the setting and routing configurations can be changed simultaneously by pressing the PRESET key.

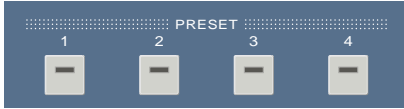

■ **NOTE:** Only the combinations of memory numbers are stored in the PRESET keys. Thus, if changes are made to the contents of the preset memory stored in a PRESET key, pressing the PRESET key recalls the changed memory contents.

■ **Illumination of PRESET Keys:** The indicator in a PRESET key is lit only when the preset is being used. Thus, the indicator in the PRESET key will go off when the memory number of the setting or routing memory is changed after the preset memory is recalled.

■ **Storing into a Preset:** To store the current combination of the setting and routing memories, hold the desired PRESET key down and press the ENTER key. When the memory combination is stored, the indicator in the PRESET key illuminates to indicate that the memory combination stored in the PRESET key is currently being used.

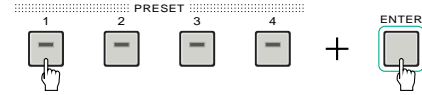

■ **NOTE:** Each PRESET key stores the setting and routing memory numbers "0" as default values.

■ **Recalling a Preset:** To recall the memory combination stored in a PRESET key, simply press the desired PRESET key. The setting and routing memories will be changed to the combination stored in the PRESET key and the current memory numbers are displayed on the initial screen. It may take a few seconds until the actual settings are changed and the LCD shows "WAIT A MOMENT..." during this time.

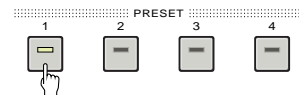

Operations in Setup Mode

■ **About Setup Mode:** Setup mode is used to make all operation settings excluding the signal routing configurations. To place the FS-96 into Setup mode, press the SETUP key so that the key's indicator illuminates. When the FS-96 is in Setup mode, the current operation settings are displayed in the LCD screens and the screens can be changed by pressing the upper & lower Arrow keys.

■ SETUP MODE INITIAL SCREEN



INPUT FORMAT:
AES

(USE **▲** **▼** TO CHANGE SCREEN)

NOTE: To leave Setup mode, press the SETUP key again so that the key's indicator goes off. If you are to move the FS-96 from Setup mode to Routing mode, you must leave Setup mode before pressing the ROUTING key.

■ **Using Setting Memories:** The FS-96 utilizes two preset memories consisting of the setting memories and routing memories. The setting memories are used to store the settings made in Setup mode and a total of 10 preset memories (No. 0 – 9) are provided for the setting memories. Note that the changes made in Setup mode will be stored into the setting memory which are currently selected. Before you make any changes to the settings, confirm that the desired preset memory number is displayed on the initial screen.

■ **Operations in Setup Mode:** The setting operations in Setup mode are made in the following manner.

1. Select the desired setting memory number on the initial screen.

The settings made in Setup mode will be stored into the setting memory currently being used.

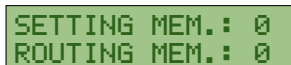

SETTING MEM.: 0
ROUTING MEM.: 0

2. Press the SETUP key to enter Setup mode.

The settings stored in the current setting memory will be displayed on the LCD. The LCD screens can be changed by pressing the upper & lower Arrow keys.



INPUT FORMAT:
AES

(USE **▲** **▼** TO CHANGE SCREEN)

3. Make the desired settings in the Setup mode screens.

Please refer to the following pages for the details of each screen. When a parameter value is stored by pressing the ENTER key, that setting will be stored into the current setting memory and the actual setting will be changed.

4. After all of the desired settings are finished, press the SETUP key to leave Setup mode and return to the initial screen.

■ **Setup Mode Screens:** Setup mode consists of the following screens.

INPUT FORMAT screen (⇨ p.17): used to select the input signal format. This screen is also used when placing the FS-96 into Bi-Direction mode.

OUTPUT SYNC screen (⇨ p.18): used to select the synchronization signal ("reference clock signal") for the output audio signals. The reference clock can be selected from three types of signals — FS-96's internal clock signal, external Word Clock signal, and input audio signal.

SAMPLE RATE CONVERT screen (⇨ p.19): used to select whether the sample rate converter is applied to the output audio signals.

OUTPUT RES. screen (⇨ p.20): used to select whether to change the bit resolution (number of quantization bits) of the output audio signals.

DITHER screen (⇨ p.20): used to select whether to apply the dither function to the audio data. Note that the dither function is needed only when the bit resolution is changed in a decreasing direction.

OUTPUT STATUS screen (⇨ p.21): used to edit the status data contained in the output audio signals.

SYNC TIMING screen (⇨ p.22): used to change the sampling timing for the input audio signals, by applying some delay to the clock signal extracted from the input audio signals. Also, the output timing of TDIF-1 signals for the WORD CLOCK signal can be adjusted.

LCD CONTRAST screen (⇨ p.23): used to adjust the contrast for the LCD screen. This setting is separate from the setting memories and a single setting is stored in the system memory.

NOTE: The current setting memory number is displayed in the upper right corner of each LCD screen.

NOTE — Blinking of SETUP Key: Normally, the indicator in the SETUP key illuminates when the FS-96 is in Setup mode and the changes made in Setup mode will be reflected instantly by pressing the ENTER key. However, some operation parameters may take a few seconds until the changes are reflected in the actual settings. In this case, the SETUP key's indicator will continue to flash to indicate that an operation parameter is currently being changed, until the change takes effect.

Selecting Input Format

The FS-96 can handle a maximum of 5 digital audio formats (ADAT, AES/EBU, SDIF-2, TDIF-1, OPTION). The signals input in the selected format will be converted to all of the formats available on the FS-96.

1. Press the **SETUP** key to place the FS-96 in Setup mode and select the **INPUT FORMAT** screen by pressing the upper & lower Arrow keys.

The current input format is displayed.

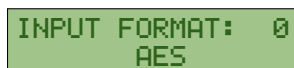

```
INPUT FORMAT: 0
AES
```

2. Press the **ENTER** key to activate the parameter.

The current selection is displayed with parentheses and the other choices are displayed on the screen.

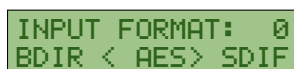

```
INPUT FORMAT: 0
BDIR < AES > SDIF
```

3. Select the desired format with the right & left Arrow keys and press the **ENTER** key to store the selection.

The selection is stored into the current setting memory and is reflected onto the actual setting.

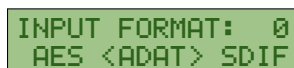

```
INPUT FORMAT: 0
AES < ADAT > SDIF
```



(USE **▲ ▼** TO SELECT INPUT FORMAT)



```
INPUT FORMAT: 0
ADAT
```

■ **List of Input Formats:** The following input formats are available in the INPUT FORMAT screen.

- AES:** selects the AES/EBU (AES3) format.
- ADAT:** selects the ADAT optical format.
- SDIF:** selects the SDIF-2 format.
- TDIF:** selects the TDIF-1 format.
- BDIR:** used to place the FS-96 in Bi-Direction mode to perform bi-directional conversions between the TDIF-1 and AES/EBU formats. Please refer to “Using Bi-Direction mode” for details (⇒ p.25).
- OPT:** selects the signal format of an expansion module inserted in the option slot.

■ **Indication of Input Format:** The selection of the input format will be displayed by the Source indicators on the front panel.



If no signal is present or if no synchronization is achieved for the input signals, the source indicator will flash to alert the operator.

NOTE: When “BDIR” (Bi-Direction mode) is selected, both the AES/EBU and TDIF-1 indicators are illuminated.

Selecting Reference Clock

The reference clock (synchronization source) signal is used to determine the sample rate and synchronization status of the FS-96. The sample rate of the audio signals will be changed to the frequency of the reference clock signal. Also, the output audio signals will be in synchronization to the reference clock signal in a phase accuracy.

1. Press the **SETUP** key to place the FS-96 in Setup mode and select the **OUTPUT SYNC** screen by pressing the upper & lower Arrow keys.

The current reference clock is displayed on the screen. If the internal clock signal ("INT") is used, the screen shows the signal frequency. If the input audio signal ("INPUT") is used, the screen shows the input signal group.

```
OUTPUT SYNC: 0
             INT 96K
```

2. Press the **ENTER** key to activate the parameter.

The current selection is displayed with parentheses and the other choices are displayed on the screen.

```
OUTPUT SYNC: 0
             WRD < INT > IPT
```

3. Select the desired signal with the right & left Arrow keys and press the **ENTER** key to store the selection.

The selection is stored into the current setting memory and is reflected onto the actual setting.

```
OUTPUT SYNC: 0
             IPT < WRD > INT
```

(USE   TO SELECT SIGNAL)

```
OUTPUT SYNC: 0
             WORD
```

When in internal clock signal ("INT") or input audio signal ("INPUT") is selected, the LCD changes to the optional screen.

NOTE — SRC Setting on Reference Clock Selection: If the sample rate converter (SRC) is turned off, attempting to change the reference clock to a signal other than the input signal (IPT or INPUT) causes the following screen to appear on the LCD. In this screen, you can activate the SRC instantly by choosing "YES". After the desired option is selected, press the **ENTER** key to change the status of the SRC.

```
ENABLE SRC? 0
             < YES > NO
```

(USE   TO SELECT YES / NO)

4. When "INT" is selected, select a frequency of the signal and press the **ENTER** key.

When "INPUT" is selected, select a input signal group and press the **ENTER** key.

The LCD returns to the OUTPUT SYNC screen.

■ FREQUENCY SELECTION FOR INTERNAL CLOCK



```
FS SETTING: 0
             44k < 48k > 64k
```

(USE   TO SELECT FREQUENCY)

```
OUTPUT SYNC: 0
             INT 48K
```

■ GROUP SELECTION FOR INPUT SIGNAL

```
GROUP SETTING: 0
                24 < CH1/2 > 3
```

(USE   TO SELECT GROUP)

```
OUTPUT SYNC: 0
             INPUT 1/2ch
```

The choices in the GROUP SETTING screen vary with the selection of the input format. When the AES/EBU format is used, selection is made for 12 channel pairs (1/2 ch – 23/24 ch). When the ADAT or the TDIF (including Bi-Direction mode) is used, selection can be made for three groups (GROUP A – C). There is no group selection for the SDIF format.

After the optional settings are made, press the **CANCEL** key to return to the OUTPUT SYNC screen. You cannot move to the other screens, once you return to the OUTPUT SYNC screen.

! If the reference clock is set to a signal other than the input audio signal (or the external Word Clock signal synchronized to the input audio signal), be sure to turn on the sample rate converter. If the sample rate converter is not activated, proper audio signals may not be output.

NOTE: When "BDIR" (Bi-Direction mode) is selected as the input format, the reference clock will be changed automatically to the group A of the TDIF-1 input.

Setup Mode

Selecting Reference Clock (Continued)

■ **List of Reference Clock Signals:** The following signals can be used as the reference clock signal.

- **INT:** selects the internal clock signal of the FS-96. The frequency of the signal can be selected from the following 6 options — 32, 44 (44.1), 48, 64, 88 (88.2), 96 kHz.
- **WORD:** selects the external Word Clock signal supplied to the WORD IN connector. The frequency of the signal varies with the setting of the external device.
- **INPUT:** selects the Word Clock signal extracted from the input audio signals. If the input audio signals consist of multiple groups, you can select which group is used (AES/EBU = INPUT 1/2 – 23/24 ch, ADAT & TDIF (including Bi-Direction mode) = GROUP A – C).

NOTE: The output audio signals will be synchronized to the reference clock signal with phase-level accuracy.

■ **Indication of Reference Clock and Sample Rate:** The selection of the reference clock signal and the sample rate of the output audio will be displayed by the Reference Clock and Sample Rate indicators on the front panel.



- **Reference Clock Indicators:** The selection of the reference clock signal is displayed by the Reference Clock indicators — INT (internal clock signal), EXT (external Word Clock signal), and INPUT (input audio signal). If no signal is present or no synchronization is achieved for the input signal, the indicator will flash.
- **Sample Rate Indicators:** Each of the indicators will illuminate when the frequency of the output signal is within a range of $\pm 1\%$ of the labeled frequencies. If the signal is 64 kHz, both the 32 kHz and 44.1 kHz indicators are lit. Also, if the signal is 88.2 kHz, both the 44.1 kHz and 48 kHz indicators are lit.

Configuring Sample Rate Converter

According to the accuracy of the devices, there are slight fluctuations or jitters in the sample rates of digital audio signals. The FS-96 is equipped with an accurate clock generation circuit and the input audio signals can be converted to accurate signals by passing through the sample rate converter.

■ **Using Sample Rate Converter:** Activation of the sample rate converter should be determined by the settings of input format and reference clock signal. If the audio signals are to be converted to a different sample rate, you must turn on the sample rate converter to obtain proper audio outputs. If the output signals is to be synchronized to the input signals (or the external Word Clock signal which is synchronized to the input signals), the sample rate converters are not necessary. However, we recommend to activate the sample rate converters all the time.

⚠ **If the sample rate of the input audio is different from the frequency of the reference clock signal, please be sure to activate the sample rate converter. If the sample rate converter is turned off, annoying noise may appear on the audio signals.**

NOTE: Status of the sample rate converter is displayed on the SRC indicator on the front panel.



1. Press the **SETUP** key to place the FS-96 in Setup mode and select the **SAMPLE RATE CONVERT** screen by pressing the upper & lower Arrow keys. The current status of the sample rate converter is displayed on the screen.

2. Press the **ENTER** key to activate the parameter. The current status is displayed with parentheses.

3. Select the activation of sample rate converters with the right & left Arrow keys. Then, press the **ENTER** key to store the setting. The setting is stored into the current setting memory and is reflected onto the actual setting.

(USE TO SELECT ON / OFF)



NOTE: When “BDIR” (Bi-Direction mode) is selected as the input format, the sample rate converter will be automatically turned off.

Setup Mode

Changing Bit Resolution

The bit resolution (the number of quantization bits) of the output audio signals can be changed from three options — 16 bits, 20 bits, and 24 bits.

NOTE: To change the bit resolution, you must turn on the sample rate converter.

1. Press the **SETUP** key to place the FS-96 in Setup mode and select the **OUTPUT RES.** screen by pressing the upper & lower Arrow keys.

The current bit resolution is displayed on the screen.

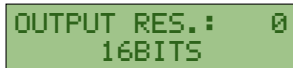

OUTPUT RES.: 0
16BITS

The FS-96 automatically detects the bit resolution of the input signals. Normally, the bit resolution of the input signals is selected in this screen.

2. Press the **ENTER** key to activate the parameter.

The current selection is displayed with parentheses and the other choices are displayed on the screen.

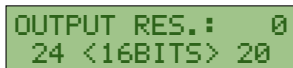



OUTPUT RES.: 0
24 <16BITS> 20

3. Select the desired bit resolution with the right & left Arrow keys. Then, press the **ENTER** key to store the selection.

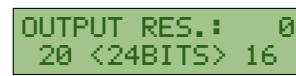
The selection is stored into the current setting memory and is reflected onto the actual setting.



OUTPUT RES.: 0
20 <24BITS> 16

(USE   TO SELECT BIT RESOLUTION)

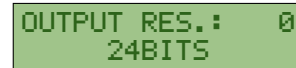

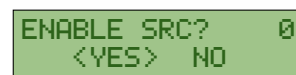

OUTPUT RES.: 0
24BITS

4. If the sample rate converter is turned off, select “YES” in the following screen and press the **ENTER** key to activate the sample rate converter.



ENABLE SRC? 0
<YES> NO

(USE   TO SELECT YES / NO)

NOTE: Status of the sample rate converter is displayed on the SRC indicator on the front panel.



Activating Dither Function

When the bit resolution is decreased, the dither function can be activated for the audio data.

■ **About Dither Function:** When the bit resolution is changed in a decreasing direction (e.g., 24 → 20 / 16, 20 → 16), distortion may appear on the audio signals since the lower bits of each sample are cut (LSB, 21st bit and later bits or 17th bit and later bits). In this case, activating the dither function causes the output audio signals to become more natural, by adding a slight noise to the audio signals before changing bit resolution.

NOTES:

- Although the dither function can decrease distortion, the signal to noise ratio may fall slightly by activating the dither function. Also, activating the dither function may add noise to the audio signals. Thus, activation of the dither function should be determined by listening to the audio signals.
- The dither function is not applied if the bit resolution is changed in an increasing direction (e.g., 16 → 20 / 24, 20 → 24), since the vacant bits will be filled with zeroes.

1. Press the **SETUP** key to place the FS-96 in Setup mode and select the **DITHER** screen by pressing the upper & lower Arrow keys.

The current status for the dither function is displayed on the screen.

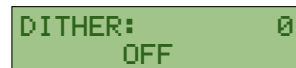

DITHER: 0
OFF

2. Press the **ENTER** key to activate the selection.

The current status is displayed with parentheses.

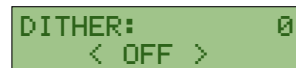



DITHER: 0
< OFF >

3. Select the activation of dither function with the right & left Arrow keys and press the **ENTER** key to store the selection.

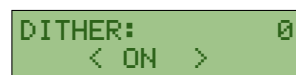
The selection is stored into the current setting memory and is reflected onto the actual setting.



DITHER: 0
< ON >

(USE   TO SELECT ON / OFF)

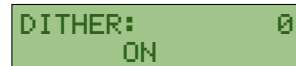

DITHER: 0
ON

Setup Mode

Editing Status Data

The status data are contained in each of the digital audio formats to indicate the status of the audio signals. The FS-96 can edit the status data for each format.

NOTE: The settings of the status data editing screens are normally set to "THRU". The status data of the input signals are not changed and are output to the external devices as they are.

 **The status data should be set properly according to the actual signal status. If the status data do not match the actual signal status, the signal may not be reproduced properly on the destination devices.**

1. Press the **SETUP** key to place the FS-96 in Setup mode and select the **OUTPUT STATUS** screen by pressing the upper & lower Arrow keys.

The status data setting screen is displayed on the LCD.

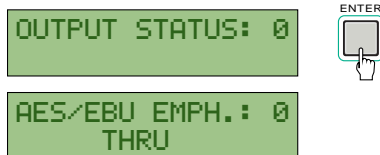

2. Select the desired item with the upper & lower Arrow keys and press the **ENTER** key to activate the parameter.

The current selection is displayed with parentheses and the other choices are displayed on the screen.

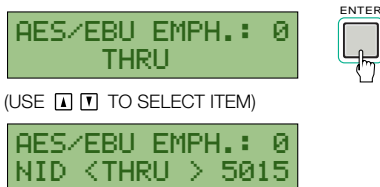

3. Select the desired value with the right & left Arrow keys and press the **ENTER** key to store the selection.

The selection is stored into the current setting memory and is reflected onto the actual setting.

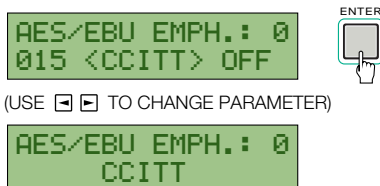

4. Repeat the steps 2 and 3, until all of the desired parameters are set.

5. After all settings are finished, press the **CANCEL** key to return to the **OUTPUT STATUS** screen. Or, press the **SETUP** key to return to the initial screen.

■ **List of Status Data:** The following status data can be edited on the FS-96.

AES/EBU EMPH. (emphasis): indicates the emphasis status of the AES/EBU signals. The following options are available: THRU (same as input), 50/15 (50/15 μ s), CCITT, OFF, NO INDICATE (no indication).

AES/EBU FREQ. (frequency): indicates the sample rate of the AES/EBU signals. The following options are available: THRU (same as input), 32k, 44k, 48k, 88k, 96k, NO INDICATE (no indication), AUTO (interlocked to reference clock).

SDIF EMPH. (emphasis): indicates the emphasis status of the SDIF-2 signals. The following options are available: THRU (same as input), ON, OFF.

TDIF EMPH. (emphasis): indicates the emphasis status of the TDIF-1 signals. The following options are available: THRU (same as input), ON, OFF.

TDIF BIT RES. (bit resolution): indicates the bit resolution of the TDIF-1 signals. The following options are available: THRU (same as input), 24BITS, 20BITS, 16BITS, AUTO (interlocked to output bit resolution).

TDIF FREQ. (frequency): indicates the sample rate of the TDIF-1 signals. The following options are available: THRU (same as input), 32k, 44k, 48k, OTHER, AUTO (interlocked to reference clock).

NOTE: The FS-96 cannot edit any status data which are not mentioned above. Such status data will not be changed from those of input signals.

 **The status data are used only to indicate the signal status. Note that the actual signal will not be changed by editing the status data.**

Adjusting Sync Timing

A digital audio signal consists of a set of audio data and a synchronization signal. The synchronization signal is used to perform audio data sampling with proper timing. If there is a gap between these two signals, the proper audio signals may not be reproduced. The FS-96 can adjust the synchronization timing of these two signals.

1. Press the **SETUP** key to place the FS-96 in Setup mode and select the **SYNC TIMING** screen by pressing the upper & lower Arrow keys.

The SYNC TIMING screen appears on the LCD.

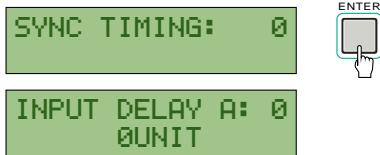

2. Select the desired item with the upper & lower Arrow keys and press the **ENTER** key to activate the parameter.

The current selection is displayed with parentheses and the other choices are displayed on the screen.

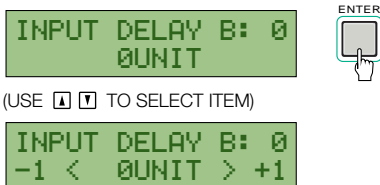

3. Select the desired value with the right & left Arrow keys and press the **ENTER** key to store the selection.

The selection is stored into the current setting memory and is reflected onto the actual setting.

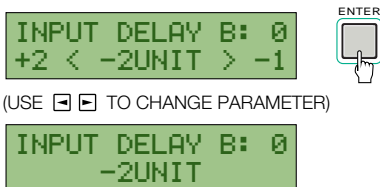

4. Repeat the steps 2 and 3 until the desired parameters are set.

5. When the parameters are set to the desired values, press the **CANCEL** key to return to the **SYNC TIMING** screen. Or, press the **SETUP** key to return to the initial screen.

■ **Parameters in SYNC TIMING Screen:** The following parameters can be set in the SYNC TIMING screen.

□ **INPUT DELAY:** used to adjust the delay for the clock signal extracted from the input audio signals, within a range of ± 2 units (1 unit = 5 ns). This will change the timing of audio data sampling relatively to the clock signal. Individual settings are possible for the three input groups for the TDIF-1 and ADAT interfaces, while a single setting is available for the SDIF interface.

□ **TDIF OUTPHASE (Output Signal Phase):** used to adjust the output timing of the TDIF-1 signals, relatively to the Word Clock signal. This will adjust the signal phases of the LR clock and audio data. Adjustment is possible in a range of ± 2 clocks ($1 \text{ clock} = \frac{1}{F_s \times 256}$).

NOTE: The above settings are normally set to "±0". If there is no problem in audio signal transmissions, the setting need not be changed.

Setup Mode

Adjusting LCD Contrast

The contrast of the LCD can be changed via the operation on the LCD. This parameter is separate from the setting memories and only a single setting is stored in the system memory.

1. Press the **SETUP** key to place the FS-96 in Setup mode and select the **LCD CONTRAST** screen by pressing the upper & lower Arrow keys.



LCD CONTRAST:

2. Press the **ENTER** key to select the screen.
The current contrast setting is displayed as a graph.



LCD CONTRAST:
<- *****--- +>

3. Adjust the screen contrast with the right & left Arrow keys and press the **ENTER** key to store the setting.
Adjust the LCD contrast so that the screen can be easily read under operating conditions.



LCD CONTRAST:
<- **----- +>



(USE   TO ADJUST CONTRAST)



LCD CONTRAST:

Configuring Signal Routing

■ **About Signal Routing:** In addition to the capabilities of signal format and sample rate conversions, the FS-96 can be used as a digital signal router. By using this function, connections of input and output channels can be changed internally, without changing any physical connections. It is possible to change the alignment of the channels or to supply the audio of a single input channel to multiple output channels.

NOTES:

- To leave Routing mode, press the ROUTING key so that the key's indicator goes off. If you are to move the FS-96 from Routing mode to Setup mode, you must leave Routing mode first before pressing the SETUP key.
- The current routing memory number is displayed in upper right corner of the routing configuration screen.
- When the signal routing is turned off (set to 1 : 1), the 1 : 1 indicator illuminates on the front panel.



■ **Using Routing Memories:** The FS-96 utilizes two preset memories consisting of the setting memories and routing memories. The routing memories are used only for storing the signal routing configurations, while the setting memories are used to store all operation settings excluding the signal routing configurations. Note that the changes made in Routing mode will be stored into the routing memory which is currently selected. Before you make any changes to the settings, confirm that the desired preset memory number is displayed on the initial screen.

NOTE: In addition to the 10 preset memories, a special routing memory ("1 : 1") is provided for deactivating the signal routing. This preset memory is automatically used when the FS-96 is placed into Bi-Direction mode.

■ **Configuring Signal Routing:** The configuration of the signal routing is made by assigning the input channels to the output channels. When configuring the signal routing, follow the instructions below.

1. Select the desired routing memory number.

The routing settings will be stored into the current routing memory. Be sure to select the proper routing memory number.

```
SETTING MEM.: 0
ROUTING MEM.: 1
```

2. Press the ROUTING key to place the FS-96 into Routing mode and confirm that the routing configuration screen appears on the LCD.

The current routing settings are displayed on the LCD. The upper line shows the output channels and the lower line shows the input channels assigned to the output channels.

```
O: 10 11 02 03 04 1 ← OUTPUT CH
I: 01 02 03 04 ← INPUT CH
```

3. Select an output channel with the right & left Arrow keys and press the ENTER key to activate the selection.

The selection of an output channel is displayed by straight bars ("|") surrounding the selected channel number. When the ENTER key is pressed, the selection moves to the input channel and the selection of the input channel is displayed with parentheses ("<" ">").

```
O: 10 9|10 11 12 1
I: 09 10 11 12
```



(USE   TO SELECT OUTPUT CHANNEL)

```
O: 09 10 11 12 1
I: <09>10 11 12
```

4. Use the right & left Arrow keys to select the input channel to be assigned to the output channel. Then, press the ENTER key to store the connection between the input and output channels.

When the ENTER key is pressed, the signal routing setting is stored into the current memory and the actual signal routing will be changed.

The selection moves to the output channel.

```
O: 09 10 11 12 1
I: <01>10 11 12
```



(USE   TO SELECT INPUT CHANNEL)

```
O: 10 9|10 11 12 1
I: 01 10 11 12
```

5. Repeat the steps 3 and 4 for the desired channels.

6. After the signal routing settings are finished, press the ROUTING key to return to the initial screen.

Bi-Direction Mode

Using Bi-Direction Mode

■ **About Bi-Directional Conversion:** The TDIF-1 interface can handle 8 channels of both inputs and outputs with a single cable and is used on many digital recorders for its ease of connection. However, when it becomes necessary to connect to a device which does not support TDIF-1 interface, a special branch cable is needed. In order to solve this problem, the FS-96 is equipped with a "Bi-Direction mode" which enables simultaneous signal format conversions in both directions between the TDIF-1 and AES/EBU interfaces.

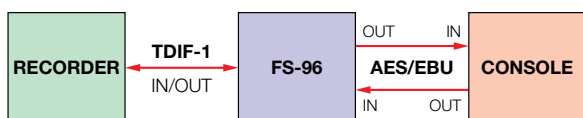

By using this function, conversion of TDIF-1 inputs to AES/EBU outputs and conversion of AES/EBU inputs to TDIF-1 outputs are performed simultaneously.

NOTE: The bi-directional conversion is possible only between the TDIF-1 and AES/EBU interfaces.

■ **Limitations in Bi-Direction mode:** When in Bi-Direction mode, the operations of the FS-96 are limited as follows:

□ **Limitations on Signal Routing:** No signal routing is possible in Bi-Direction mode. The signal routing will be deactivated and a special routing memory is used, indicating "1 : 1" as the routing memory number on the initial screen. If the ROUTING key is pressed, or if the routing memory is selected, the following screen appears for about 2 seconds.

```
BI-DIR MODE
1:1 ROUTING ONLY
```

□ **Limitations on Reference Clock:** The reference clock for the output audio signals should be set to the TDIF-1 input signals or the external Word Clock signal that is synchronized to the TDIF-1 input signals. Although the reference clock can be set to the other signals, the audio signals will be output with no synchronization. When "BDIR" is selected in the INPUT FORMAT screen, the reference clock will be changed automatically to the groups A of the TDIF-1 input signals.

□ **Limitations on Sample Rate Converters:** The status of the sample rate converters cannot be changed. Even if the sample rate converter is activated, it will be turned off automatically by entering into Bi-Direction mode. If the sample rate converter is turned on, the following screen appears for about 2 seconds.

```
BI-DIR MODE
SRC NOT AVAIL.
```

■ **Activating Bi-Direction mode:** To use the FS-96 in Bi-Direction mode, follow the instructions below.

1. Confirm that the connections are properly made to the TDIF-1 and AES/EBU interfaces.
2. Turn on the power to the FS-96 and select the desired setting memory.
3. Place the FS-96 into Setup mode by pressing the **SETUP** key and select the **INPUT FORMAT** screen. Then, press the **ENTER** key to activate the current input format selection.

```
INPUT FORMAT: 0
BDIR < AES > ADAT
```

4. Use the right & left Arrow keys and select "BDIR (Bi-Direction)". Then, press the **ENTER** key to store the selection.

The selection is stored into the current setting memory and the FS-96 is now placed in Bi-Direction mode.

```
INPUT FORMAT: 0
TDIF < BDIR > AES
```

(USE TO SELECT INPUT FORMAT)



```
INPUT FORMAT: 0
BDIR
```

When in Bi-Direction mode, the FS-96 operates as follows:

- Both the AES/EBU and TDIF-1 indicators are lit. The indicators will flash if the signal is not present or if the synchronization cannot be achieved for the input signal.
- The reference clock for the output signals is changed to the group A of the TDIF-1 input and the INPUT indicator of the Reference Clock indicators is lit. If no signal is present, or if the synchronization cannot be achieved for the input signal, the indicator will flash.
- No routing memory is used and the signal routing is turned off. The 1 : 1 indicator illuminates on the front panel. The display of the initial screen will be changed as follows:

```
SETTING MEM.: 0
ROUTING MEM.: 1:1
```

- The sample rate converters are turned off and the SRC indicator goes off on the front panel.

Specifications

FS-96 Specifications

ADAT Format Inputs and Outputs:

Signal Format: Alesis Fiberoptic Multichannel
Connector: Input: EIAJ fiber optic jack x 3
Output: EIAJ fiber optic jack x 3

AES/EBU (AES3) Format Inputs and Outputs:

Signal Format: EIAJ CP1201, IEC60958, AES3
Impedance: 110 Ω (both input & output)
Connector: Input: D-sub 25-pin (female) x 3
Output: D-sub 25-pin (female) x 3

SDIF-2 Format Inputs and Outputs:

Signal Format: SDIF-II
Impedance: 110 Ω (both input & output)
Connector: Audio Input: D-sub 50-pin (male) x 1
Audio Output: D-sub 50-pin (female) x 1
Word Clock Input & Output:
BNC type (75 Ω , TTL) x 2

TDIF-1 Format Inputs and Outputs:

Signal Format: TDIF-1
Impedance: Input: Min. 1 k Ω
Output: 56 Ω \pm 20 %
Connector: D-sub 25-pin (female) x 3

External Synchronization Input and Output:

Signal Type: Word clock
Format: Sync to rising edge of square wave
Electrical Characteristics: TTL level
Impedance: 75 Ω (both input & output)
Connector: BNC type x 2 (input x 1, output x 1)

Digital Audio Format:

ADAT, AES/EBU, SDIF-2, TDIF-1
An option slot for the expansion module is provided on the rear panel.

Number of Channels:

24, with signal routing function

Sample Rate:

28 kHz – 108 kHz variable

Number of Quantization Bits:

16 / 20 / 24 bits, switchable

The bit resolution of the input signals is detected automatically.

Signal Delay:

2–3 samples

Liquid Crystal Display:

16 characters x 2 lines,
with backlight mechanism

Dimensions (W x H x D, without projections):

482 x 88 (2U) x 380 mm

Weight:

6.0 kg

Power Supply:

100 – 240 VAC
(single phase, 50 / 60 Hz)

Power Consumption:

Maximum 50 W

Operation Environment:

Temperature: 5 – 40 $^{\circ}$ C

Humidity: 20 – 80 %

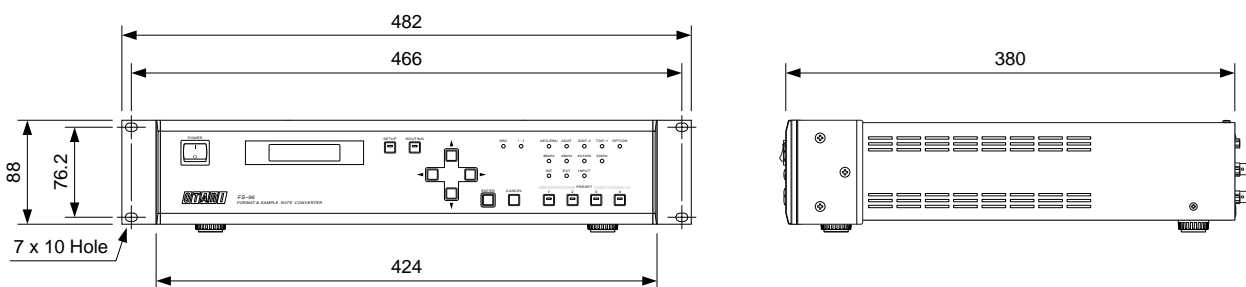

Specifications are subject to change without notice or obligation.



Otari, Inc.

4-33-3 Kokuryo-cho, Chofu-shi, Tokyo 182-0022 Japan • Phone : +81/424-81-8626 • Fax : +81/424-81-8633

Otari Corporation

8236 Remmet Avenue, Canoga Park, California 91304 U.S.A. • Phone : +1/818-598-1200 • Fax : +1/818-594-7208

Otari Europe GmbH

Rudolf-Diesel-Strasse 12, D-40670 Meerbusch, Germany • Phone : +49/2159-50861 • Fax : +49/2159-1778

Otari Singapore Pte., Ltd.

701 Sims Drive #02-02 LHK Building, Singapore 387383 • Phone : +65/846-1553 • Fax : +65/846-7875