

JH-500D Series



Superior by design.

After designing and building more professional recording systems than any other manufacturer, it's only natural for MCI to create new standards of performance in the JH-500D series.

From the moment you first see this new console, you are confident the ergonomic designs which have made MCI famous will help you create the perfect mix.

You bring up the monitors and a new sound quality is heard — clean, true, transparent. New transformerless I/O modules with distortion free circuitry provide all the operational headroom needed to capture the subtle nuances of any instrument or vocalist.

As you use this new console, your respect for it increases, your confidence is assured.

The new JH-500D . . . the ultimate tool for musical artistry.

I/O Module: Input/Output modules are self contained units which can plug into any input position. Inputs and outputs are all balanced, differential, and transformerless.

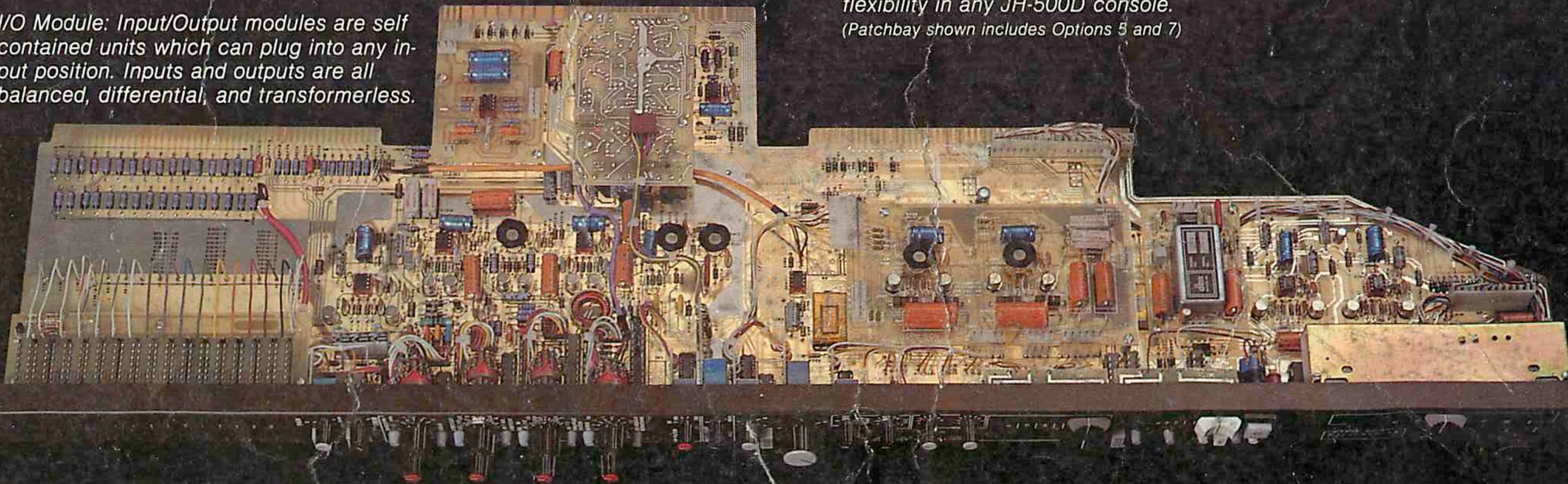

Patch Bay: An extensive patch bay is standard, providing tremendous flexibility in any JH-500D console. (Patchbay shown includes Options 5 and 7)

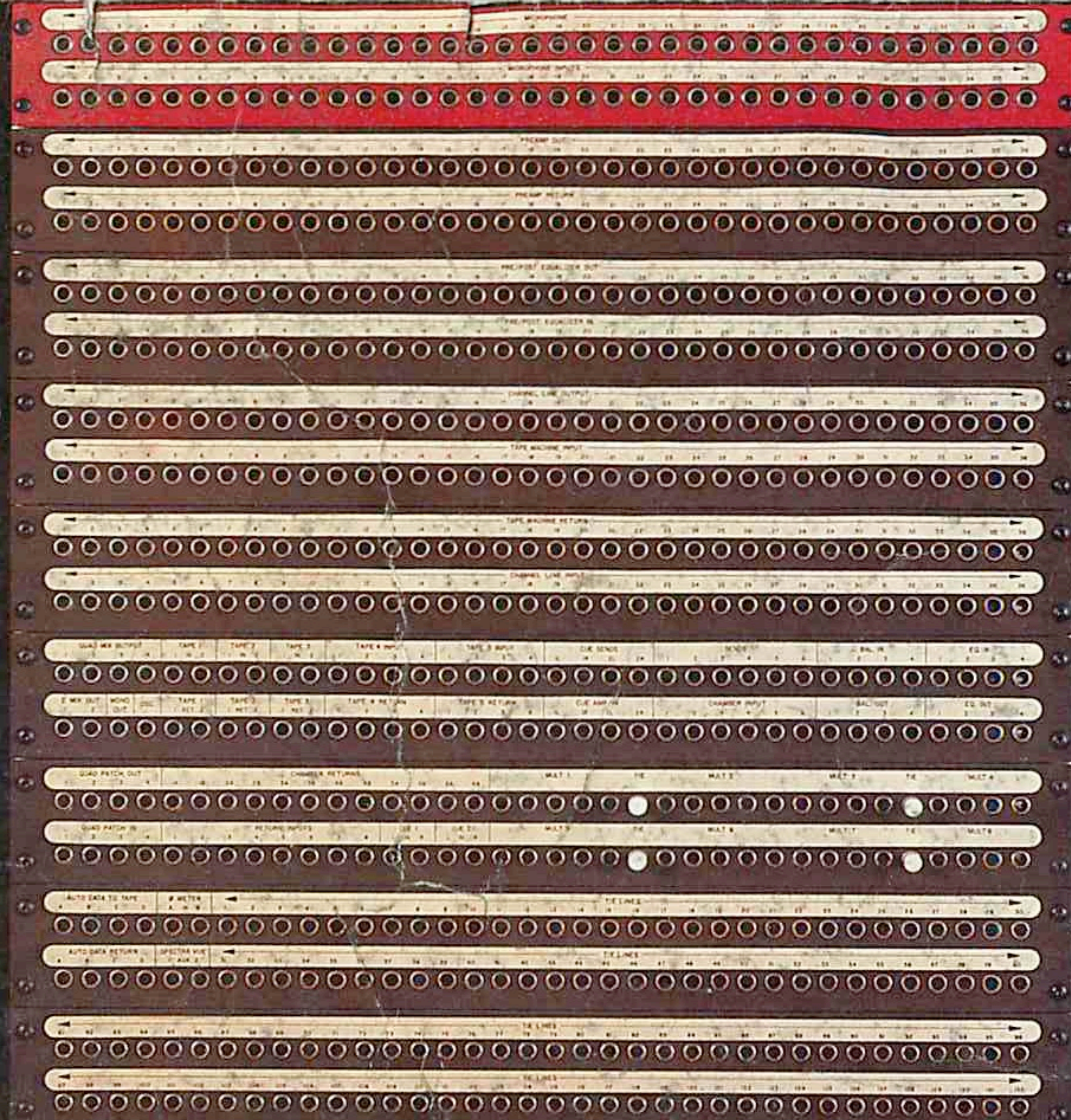



Plasma Display: High resolution 100-segment plasma displays can monitor audio or DC levels, and are switchable to either PPM or VU ballistics.

Confidence begins with "in-line" I/O modules, totally transformerless; utilizing the latest in Op-Amp circuitry.

The musically designed equalizer offers you tasteful tailoring of instrumental or vocal sound and timbre, with four band stepped controls for easy resetability. A variable high pass filter is also included, and six separate sends are at your command for foldback and effects.

Your new JH-500D comes equipped with MCI's patented plasma display metering, 32 output assignments, 8 VCA groups, as well as complete monitoring and communications facilities.

Choose your new console from any of six mainframe sizes, then customize your selection from one of the largest option groups available, including a built-in spectrum analyzer, additional equalizers, extra echo returns, a variety of producer's desks, and much, much more.

The JH-500D welcomes you to the world of automated mix-down with a human engineered system that makes automated mixing as natural as hands-on fader control. Available on the JH-500D, the MCI Microprocessor-based automation enables you to create a mix, then modify or recall it totally, all with astonishing ease.

Confidence in this industry-standard system grows with every use, as you learn to appreciate features like independent storage of mutes and fader levels, automatic nulling of faders in the update mode, and no delay action... even during repeated updates.

As your hands touch the impressive array of controls and signal modifiers, your eyes follow instantly to MCI's unique plasma display system. This patented technology keeps you in touch with all levels; visually accurately, and beautifully. Each bar graph is directly above the corresponding channel's fader, visually tied in for rapid, error-free indications. The 100-segment readouts offer resolution superior to

any mechanical meters, with ballistic and scale characteristics you can select. Softly illuminated scale markings from electroluminescent panels complete this display system, providing dramatic counterpoint to the glow of neon display elements.

You can even order the Spectra-Vue option, which enables spectral analysis of any audio signal, either internal or external to the console.

The new JH-500D recording/remixing console. The dream machine of Tomorrow, available Today. From MCI.

Input/Output Module Signal Flow exhibits extreme versatility for Recording, Remix, Live or Broadcast Applications.

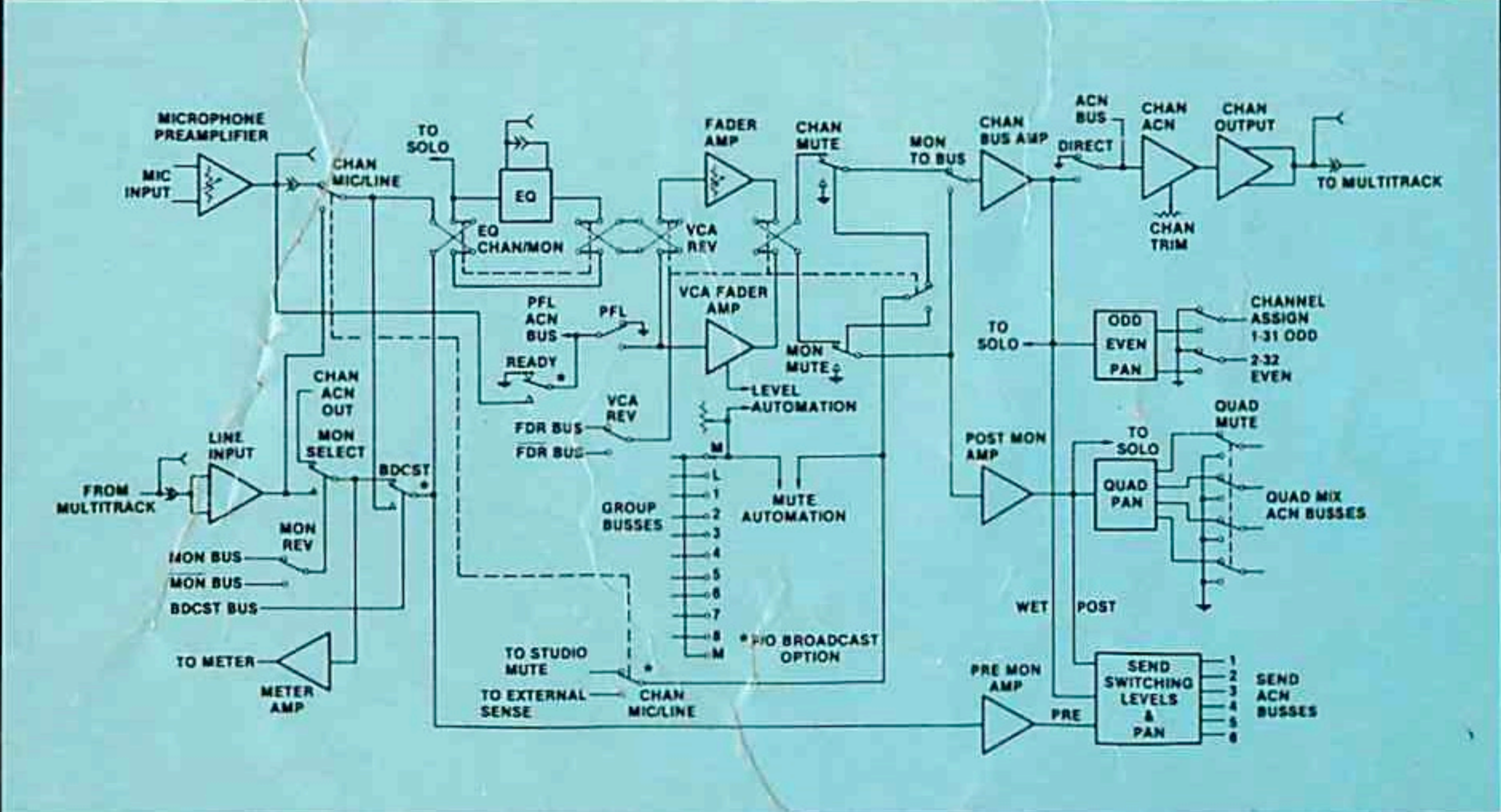



1400 West Commercial Boulevard, Fort Lauderdale, Florida 33309 USA.
Telephone: (305) 491-0825. Telex: 514362 MCI FTL.

TWA0500-0005-A