

PLUG-IN AMPLIFIERS

BY
Langevin

TYPE 116-B... TYPE 117-A

*Complete Plug-In Audio Facilities
with Only 2 Types of Amplifiers
2 Types of Vacuum Tubes*

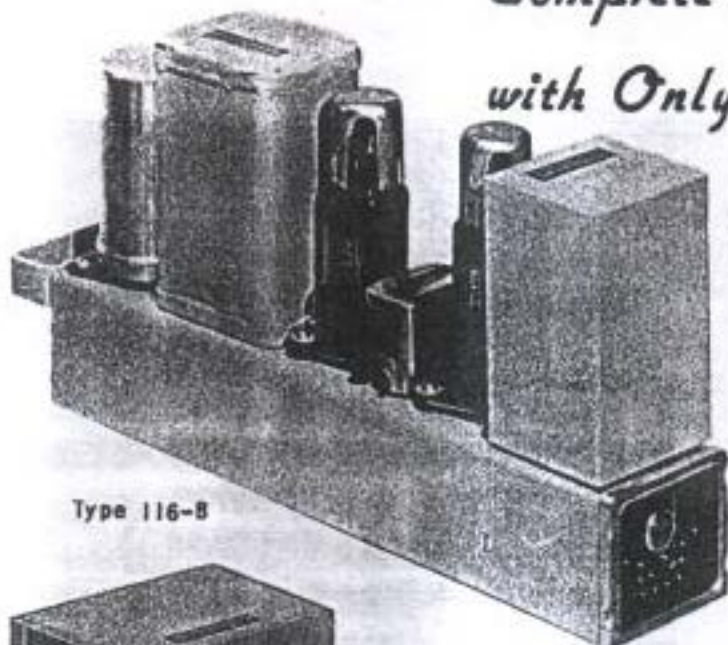

Type 116-B



Type 117-A

- STUDIOS STAY IN SERVICE
- LOWER OPERATING COST
- LOWER MAINTENANCE COST
- LOWER INVENTORIES
- RACK SPACE-SAVERS
- AMPLIFIERS EXCEED FCC QUALITY REQUIREMENTS FOR FM
- AMPLIFIERS PROVIDE HIGH OVERLOAD SAFETY FACTOR

MAXSON INSTRUMENT CORP. • LONG ISLAND CITY, N.Y.

The equipment herein described is licensed under U. S. patents of the A.T.&T. Co. and the Western Electric Company.

Langevin



TYPE 117-A

Program, Booster or Monitor Amplifier

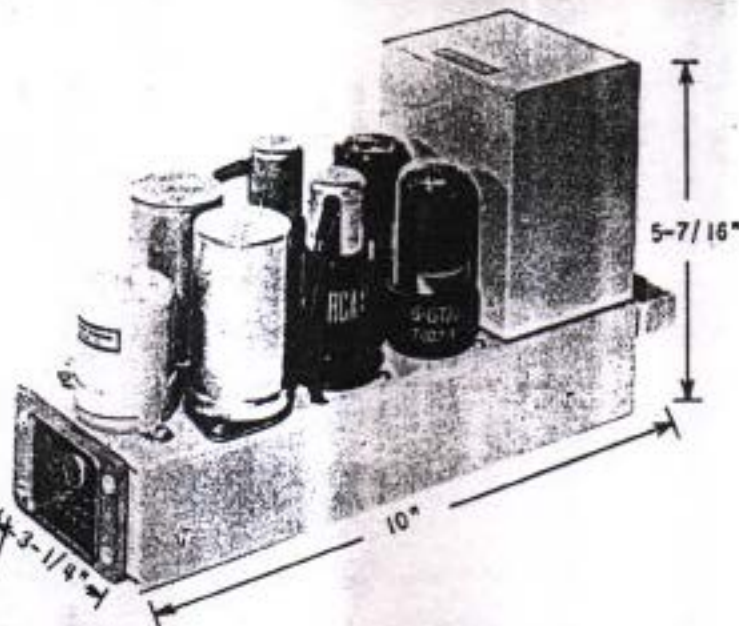

Electrical Characteristics

GAIN: 50 db.

TUBE COMPLEMENT: Two 1620, two 6V6GT.

OUTPUT POWER: +30 DBM (1 watt) with less than .5% RMS total harmonic distortion over the range 50-15,000 cycles and less than 1% total distortion over the range 30-15,000 cycles. As a monitor amplifier, +39 DBM (8 watts) with less than 1% total RMS harmonic distortion over the range 50-10,000 cycles.

OUTPUT NOISE: Unweighted, equivalent to an input signal of -110 to -114 DBM, depending upon tubes, over the band 50 to 15,000 cycles.

FREQUENCY CHARACTERISTIC: ± 1 db over the range 30 to 15,000 cycles.

INPUT SOURCE IMPEDANCE: 30/150/250/600 Ohms. Center taps are available when strapped for 150 or 600 Ohms.

OUTPUT LOAD IMPEDANCE: 150 or 600 Ohms. Center tap is available when strapped for 600 Ohms.

EXTERNAL POWER REQUIREMENTS: Filament 6.3 Volts AC at 1.5 amperes. Plate: 300 Volts DC at 75 Milliamperes.

METERING: Metering connections are available at the plug for external reading of cathode currents of the individual tubes. If it is desired to mount metering switches on the amplifier, knockouts for four Grayhill #4001 push button switches are provided on the rear apron (handle end) of the chassis.

Mechanical Characteristics

SIZE: Length: 10 in., width: 3-1/4 in., height: 5-1/2 in.

WEIGHT: 6-1/2 lbs.

SHIPPING WEIGHT: 8 lbs.

FINISH: Light grey baked enamel over 16 gauge Bonderized (rustproofed) steel.



Small Size

Rack space can be used to the fullest advantage with PLUG-IN amplifiers, as it is possible to mount 6 pre-amplifiers (Type 116-B) or 4 Program amplifiers (Type 117-A) in 7 inches of rack space. (See page four for mounting details). The small physical size of the PLUG-IN units makes them readily adaptable to console installation.

Maintenance Advantages

PLUG-IN amplifiers are easily removed from equipment racks or consoles for preventive maintenance checks at the service bench. Studio operation can be maintained with replacement amplifiers.

Overall Economy

Simplification of broadcast audio facilities to only two types of amplifiers, and only two types of tubes, 1620's and 6V6GT's makes possible station economies by decreasing tube and amplifier inventories.

RACK MOUNTING DETAILS

The Langevin Rack Mounting Assembly for PLUG-IN amplifiers is a unit which occupies only 7 inches of standard equipment rack space, and can accommodate various combinations of the two types of amplifiers

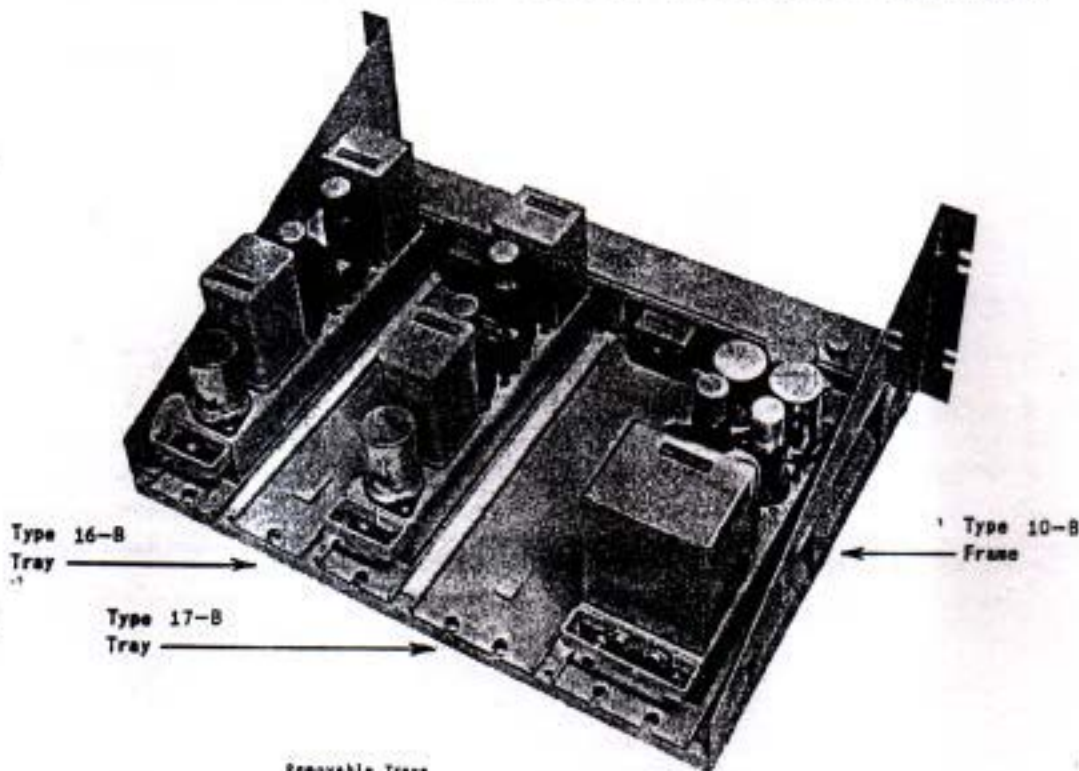

Removable Trays

The assembly is constructed with two sizes of removable trays, Type 16-B and Type 17-B, each having a plug receptacle mounted on it. Trays may be arranged on the basic frame, Type 10-B, so that the following combinations of amplifiers can be achieved: (Mating Plug receptacles are not supplied with trays; they should be ordered separately).

Six Type 116-B Pre-Amplifiers

or

Four Type 117-A Program Amplifiers.

or

Three Type 116-B Pre-Amplifiers and two Type 117-A Program Amplifiers.

or

Four Type 116-B Pre-Amplifiers and one Type 117-A Program Amplifier.

In the illustration above, trays for a combination of three pre-amplifiers and two program amplifiers have been assembled on the basic frame. The assembly, as shown, will allow removal of the amplifiers from the rear of an equipment rack. However, if it is desired to plug the amplifiers in from the front side of a rack, the mounting trays can be reversed on the basic frame.

Cabling

All cabling is run through the channel located directly behind the plug receptacles, and a removable cover over the cable channel allows easy access to the plugs for wiring purposes.

Overall Specifications

Height: 7 in. Width: 16-3/4 in. Depth: 12 in. Weight: 10 lbs.

Power Supplies

Three types of plug-in power supplies providing plate and filament power are available for operation of the 116-B and 117-A Amplifiers. The electrical characteristics and mounting details of these three types are tabulated below:

Type	AC LINE SUPPLY	PLATE SUPPLY	FILAMENT SUPPLY	RECTIFIER TYPE	MOUNTING ACCESSORIES
206-B	105-125V 210-250V 50/60 cycles	210 wa. max. at 270 to 350V	6.3V 8 amps.	Selenium Cell	19-A Mounting Tray 33-B Receptacle
208-A	105-125V 50/60 cycles	110 wa. max. at 175V	6.3V 4 amps.	5Y2GT Tube	17-B Mounting Tray 33-B Receptacle
210-A	105-125V 210-250V 50/60 cycles	425 wa. max. at 300V	2 e 6.3V 8 amps.	Selenium Cell	20-A Mounting Tray 33-B Receptacle



External Connections

Plug Pin Numbers	External Connections
1-2	Input (Note #1)
3	Chassis Ground
4-5	Output (Note #2)
5	Tube current meter (if metering push buttons used)
7	Tube current meter (positive) VT-1
8	Tube current meter (positive) VT-3
9	Tube current meter (positive) VI-2
10	Tube current meter (positive) VT-4
11-12	Filament 3.3 volts AC 1.5 amps.
13	B- and meter (negative)
14	B+ 300 volts DC

Note #1 - On unbalanced input circuits, the grounded side should be connected to Pin #1.

Note #2 - On unbalanced output circuits, the grounded side should be connected to Pin #5.

Metering Circuits

Metering Circuits are designed to measure the cathode current of the individual tubes expressed as a percentage of a normal tube, using a meter having a 200 microampere movement. A series resistor should be added so that the total resistance of the meter and resistor is 1000 Ohms. The meter scale should be calibrated so that nominal cathode current (100%) will read at 75% of full scale.

The meter recommended for the above is the Tube Check Meter (Weston 506 Special) available from Langevin. This meter has a 3" sq. face, black background, white lines and letters, and special calibrated scale as described above.

The amplifier is wired for metering connections of the individual tubes brought out to pins on the plug, for use with external meter switches. For metering the tubes at the amplifier, provision has been made for two push button switches at the handle end of the chassis. Four Grayhill #4001 Push Button Switches, with instructions for installation on the 117-A Amplifier, may be obtained by ordering the 20-A Modification Group, or 117-A Amplifiers may be ordered with the 20-A Modification installed at the factory.

Grounding

Connect the main ground to pin number 3 on the plug receptacle. Ground the negative side of the plate supply in the following manner: When only one amplifier is being used, strap pin number 13 to pin number 3. When several amplifiers are used in a system, and obtain plate power from a common source, apply the ground at only one point in the system.

The filament center tap of the power supply should be grounded. In some cases, however, it may be necessary to apply positive bias to the filament center tap with respect to ground, in order to reduce hum caused by filament to cathode leakage. In this event, a resistance can be connected across the plate voltage supply so that a portion of the plate voltage, 5 to 12 volts, can be tapped off and fed to the filament center tap.

Impedance

The 117-A Amplifier, as shipped, is connected to work from a source impedance of 300 Ohms and into a load impedance of 600 Ohms. If other impedances are desired, the amplifier may be re-strapped according to the table on the circuit diagram. Strapping for the input is accomplished on the resistor strip; for the output on the output transformer.

Reduced Plate Voltage

When the 117-A Amplifier is used as a program or booster amplifier, the plate voltage may be reduced to 275 volts with a current drain of approximately 65 MA without appreciably reducing the output power...thus prolonging tube life.

Center Taps

Center taps are available on the input of the 117-A Amplifier when the unit is strapped for 150 or 600 Ohms, and on the output when strapped for 600 Ohms. The input center tap can be grounded on the resistor strip. In order to ground the output center tap, run an additional wire from a ground point to the output transformer terminals.

Tube Substitutions

In an emergency, if the 1620 vacuum tube is not available, a 6J7 tube can be substituted. This substitution may result in a decrease in output power and an increase in output noise level.

Power Supplies

Four types of power supplies providing plate and filament power are available for operation of the Langevin 117-A Amplifier (and 116-B Amplifier), three of which are plug-in types. The electrical characteristics and mounting details of these four types are tabulated below:

TYPE	AC LINE SUPPLY	PLATE SUPPLY	FILAMENT SUPPLY	RECTIFIER TYPE	MOUNTING	MOUNTING ACCESSORIES
205-B	100-130V 200/280V 50/60cycles	425 ma.max.at 220 to 300V 150 ma.max.at 180 to 260V	2 @ 6.3V 8 amps.	Selenium Cell	Rack (10 $\frac{1}{2}$ ")	36F Hat Panel (Supplied)
206-B	105-125V 210-250V 50/60cycles	210 ma.max.at 270 to 350V	6.3V 8 amps.	Selenium Cell	Plug-in	19-A Mounting Tray on 10-B Mounting Frame 33-S Receptacle
208-A	105-125V 50/60cycles	110 ma.max.at 275V	6.3V 8 amps.	5Y3GT Tube	Plug-in	17-B Mounting Tray on 10-B Mounting Frame 33-S Receptacle
210-A	105-125V 210-250V 50/60cycles	425 ma.max.at 300V	2 @ 6.3V 8 amps.	Selenium Cell	Plug-in	20-A Mounting Tray on 10-B Mounting Frame 33-S Receptacle

Mounting Accessories

All Langevin PLUG-IN Amplifiers and Power Supplies are designed to mount in Mounting Trays equipped with bracket for attaching the 33-S Receptacle. These trays mount on a 10-B Mounting Frame, which occupies 7" of standard rack space. The 117-A Amplifier requires a 17-B Mounting Tray; the 116-B Amplifier requires the 16-B Mounting Tray. The 10-B Mounting Frame will accommodate six 116-B Amplifiers, or four 117-A Amplifiers or various combinations of both.

Because of noise pick-up, it is recommended that no power supply be mounted on the same mounting frame with amplifiers. A 10-B Mounting Frame will accommodate four 208-A Power Supplies, two 206-B Power Supplies or one 210-A Power Supply.

Mounting accessories and receptacles are not supplied with amplifiers and power supplies; they should be ordered separately.

REVISIONS
 2 LMA. 6-1-55
 DWG. NO. WRS
 A-2909 MJT
 3 J. Y. 12-11-56
 REVISED VT-1, 2, 3, 4
 4 JM 9-29-59
 ADDED SW-1-4 PER V.M.
 5 ADDED C-5/C-6
 9-26-61 d/m C.

SCHEMATIC DIAGRAM
 117-A AMPLIFIER

DR. BY: J.L.
 CK. BY:
 SCALE:

THE
 LANGEVIN CO.
 NEW YORK

ENG.
 DATE: 9-27-49
 DR. NO.: A117-1-3

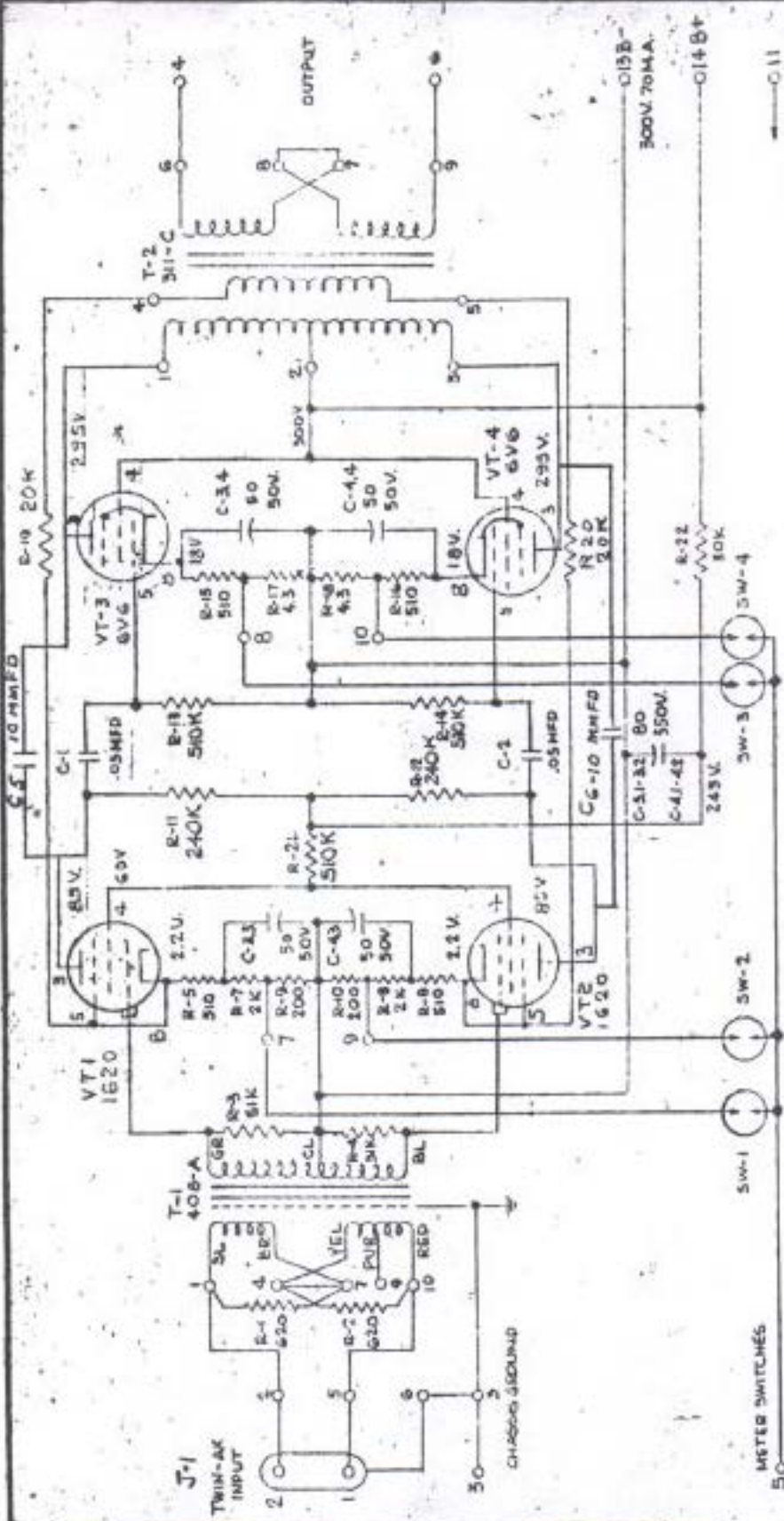

STRAPPING ON OUTPUT TRANSFORMER
 7-6
 6-8, 7-9

OUTPUT IMPEDANCE
 600Ω
 150Ω

STRAPPING ON RESISTOR STEP
 1-2, 4-7, 8-10
 1-2, 4-7, 5-9
 1-2-4, 5-7-10
 2-9, 5-13

INPUT IMPEDANCE
 600Ω
 250Ω
 150Ω
 50Ω

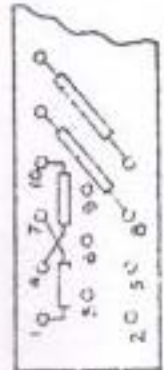

RESISTOR STRIP NUMBERING

NOTE: THE VOLTAGES SHOWN ARE TYPICAL
 AVERAGE VALUES OBTAINED USING A
 11 MEGOHM VOLTMETER WITH NO SIGNAL
 INPUT AND CONNECTED TO POWER
 SUPPLIES INDICATED
 VOLTAGES ARE IN REFERENCE TO B-