

1963

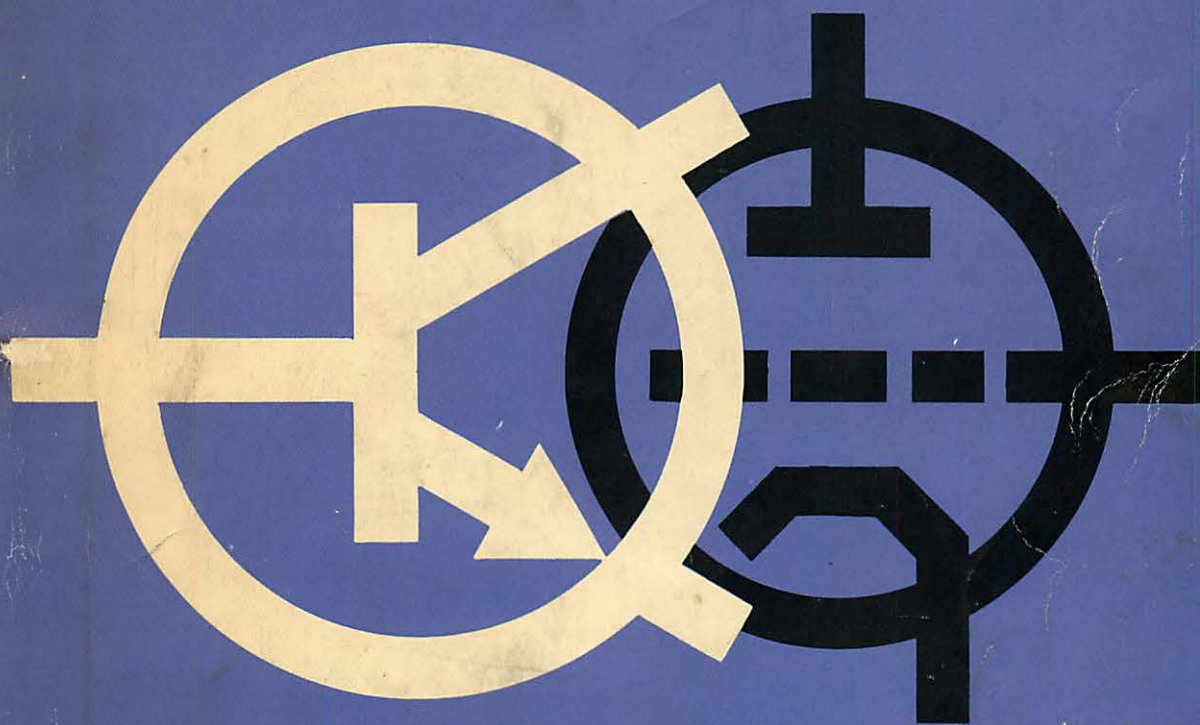

AUDIO EQUIPMENT

A DIVISION OF SONOTEC INCORPORATED • Export: Simonrice
503 South Grand Avenue, Santa Ana, California

CATALOG 408
PRICE \$1.00

HOW TO BUY LANGEVIN PROFESSIONAL AUDIO PRODUCTS

Users of Langevin audio products are served by qualified distributors of professional audio equipment in key cities throughout the world. If you do not know the name of the nearest Langevin distributor contact the factory sales department or call your nearest representative whose name appears on the right column of this page.

IF REMOTELY LOCATED

If you are not served by a Langevin representative or distributor in your area, place your order with the factory.

TERMS

Terms are cash in advance to unrated accounts unless credit has been established with the factory. Open accounts are billed 1%, 10 days, 30 days net, FOB Santa Ana, California.

HOW TO BUY

Rated accounts, or others who have established agreeable credit relationships, may order open account. For speedy service, new customers may accompany their order with a check. It is normal practice to ship freight charges collect for the convenience of the customer and also for the convenience of Langevin, as this simplifies billing procedures. If otherwise instructed, Langevin will ship prepaid and bill for charges.

SPECIFY SHIPPING METHOD

The customer should specify the shipping method, otherwise Langevin will ship the best way at lowest cost. This will in many cases be by motor freight if the shipment approaches 100 lbs., or heavier. 35 lbs. approximately is the breaking point for Railway Express, and is somewhat faster. United Parcel Service is available from Santa Ana and gives good service into Chicago and New York at Parcel Post rates; check the UP office in your city.

Langevin positively will not ship amplifiers or equipment sensitive to rough handling by regular Parcel Post except at the customers request.

If in doubt as to the manner in which shipment should be made, mark your order "Ship Best Way", and Langevin's skilled Traffic Department will insure most economical freight charges consistent with speed and safety of arrival.

WORLD EXPORT

Export correspondence regarding orders should be referred directly to: Langevin Export Division, M. Simons & Son Co., Inc. 25 Warren Street, New York 7, N. Y., Telephone: Barclay 7-5513. Cable: "SIMONTRICE"

CANADA

MA forms should accompany order and be sent direct to the factory.

OVERSEAS POSSESSIONS

Correspondence and orders should be addressed directly to the factory.

EXPORT PACKAGING

A nominal charge is made for export packaging.

FACTORY FIELD REPRESENTATIVES

Albuquerque, New Mexico

Hyde Electronics Co., 5206 Constitution Ave., NE
Telephone: 243-9524, Area Code: 505

Atlanta 13, Georgia

Maitland K. Smith Co., 208 14th Street, NW
Telephone: Trinity 5-8031, Area Code: 404

Birmingham 13, Alabama

Maitland K. Smith Co., 2805½ Cahaba Road
Telephone Tremont 9-7197, Area Code: 205

Charlotte 5, North Carolina

Maitland K. Smith Co., 1605 Chatham Avenue
Telephone: Franklin 6-5951, Area Code: 704

Chicago 41, Illinois

Irving W. Rose Associates, 4358 Montrose Avenue
Telephone: Avenue 2-6835, Area Code: 312

Cleveland 15, Ohio

Schroeder Sales Co., 2254 Euclid Avenue
Telephone: Main 1-5075, Area Code: 216

Dallas 17, Texas

Jack Yount Company, P.O. Box 17270, 1431 Pleasant Drive
Telephone: Express 1-4125, Area Code: 214

Denver 23, Colorado

Hyde Electronics Co., 888 So. Lipan Street
Telephone: 292-3595, Area Code: 303

Detroit 27, Michigan

Wayne Beitel Company, 13209 Fenkell
Telephone: Vermont 8-9100, Area Code: 212

Downsview, Ontario, Canada

Samuel C. Hooker (Canada) Ltd., P.O. Box 217
Telephone: 635-1470, Area Code: 416

Hartford 5, Conn.

Zaslow Sales Co., 526 Farmington Avenue
Telephone: Adams 6-3265, Area Code: 203

Indianapolis 26, Indiana

Harrison J. Blind Associates, 5762 Cadillac Drive
Telephone: Chapel 4-0191, Area Code: 317

Los Angeles 46, California

Koessler Sales Company, 818 N. Fairfax Ave.
Telephone: Olive 3-1605, Area Code: 213

Manlius, New York

William M. Ferguson Co., 117 Fayette Street
Telephone: Overbrook 2-9301, Area Code: 315

Montreal, Quebec, Canada

Samuel C. Hooker (Canada) Ltd., 2425 Grand Blvd.
Telephone: 488-9114, Area Code: 514

Northboro, Mass.

Zaslow Sales Co., 371 Howard Street
Telephone: EX 3-8170, Area Code: 617

Ormond Beach, Florida

Maitland K. Smith Co., 322 Riverside Drive
Telephone: Orange 7-2298, Area Code: 305

Phoenix 4, Arizona

Hyde Electronics Co., 2727 North Central Avenue
Telephone: 265-7313, Area Code: 602

Port Washington, New York

Carduner Sales Co., 80 Shore Road
Telephone: Port Washington 7-7700, Area Code: 516

St. Louis 19, Missouri

Robert Shaw Co., 7800 Kenridge Lane
Telephone: Woodland 2-7429, Area Code: 314

Salt Lake City 11, Utah

Hyde Electronics Co., 85 East 7th Street
Telephone: 359-1661, Area Code: 801

San Francisco 24, California

Koessler Sales Company, 2803 Geneva Ave.
Telephone: Judson 4-1808, Area Code: 415

Seattle 1, Washington

William R. Lanphear Co., 159 Western Avenue West
Telephone: Atwater 4-8150, Area Code: 206

Tampa, Florida

Maitland K. Smith Co., 3810 Barcelona
Telephone: 833-8331, Area Code: 813

Washington 12, D. C.

Art Gaines Co., 225 Vine Street, NW, Suite 200
Telephone: TU 2-4655, Area Code: 202

World Export

M. Simon & Son Co., Inc., 23-25 Warren Street
New York 17, N.Y. — Cable Address: SIMONTRICE
Telephone: Barclay 7-5513, Area Code: 212

North Dakota—South Dakota—Minnesota

Langevin, 503 So. Grand Ave., Santa Ana, Calif.
Telephone: KImberly 7-6204, Area Code: 714

PREPARED FOR THE PROFESSIONAL USER

This catalogue is
**A GUIDE TO CHOOSING
ALL THE EQUIPMENT YOU NEED
BETWEEN THE MICROPHONE AND
SPEAKER TERMINALS**

SHOULD YOU SELECT TRANSISTOR OR TUBE TYPE AMPLIFIERS?

Langevin has successfully completed over 36 months of laboratory and field tests on its solid state amplifiers and offers them for the first time in this catalogue. These are recommended over tube types on all counts, and especially for signal-to-noise, where a significant breakthrough has been achieved.

IF YOU WANT COMPLETE CONTROL CONSOLES —

The first pages show you the CSL-1200 series in both tube and transistor types. The 1200 series accommodates the largest users, TV-Broadcast customers. But because the higher signal-to-noise ratios of "recording" quality rather than simply "broadcast" quality are incorporated, recordists requiring a simple system will find top quality and high value in these units.

CUSTOM BUILDERS ARE WELL SERVED THROUGH THESE PAGES

Starting with modern console housings, a selection is offered starting with a 30 inch width and increasing in 6" increments to 60 inches. All amplifiers in either transistor or tube types are available, and, importantly, they fit. When you select Langevin keys, switches, attenuators, equalizers, filters, networks and meter assemblies, you know that by following Langevin's layout suggestions you can conserve space, facilitate wiring and achieve professional appearance and results.

LAYOUT, DRILLING AND PANEL ENGRAVING SERVICE

Langevin recognizes that this type of service is hard to find in the field, and for purchasers of its equipment offers panel layout, fabricating and engraving service at only nominal cost.

YOU SELECT THE RIGHT EQUIPMENT FOR THE JOB IF YOU READ THE GENERAL INFORMATION AT THE BEGINNING OF EACH SECTION BEFORE ORDERING

ATTENUATORS AND MIXERS

When you choose attenuators or mixer controls you save money and get better performance if you read the several pages of general information at the start of the section.

EQUALIZERS AND FILTERS

Pages 42 and 43 discuss the subjective effects of equalization on various portions of the spectrum. Through a proper understanding of these effects you select fixed filters or variable equalizers to give desired results.

COMBINING NETWORKS AND FIXED LOSS PADS

Langevin gives you the tables, formulas and other data needed to design your own; sometimes money can be saved by doing so. But the resistances frequently turn out to be odd values and are not easily obtainable. Installation is complicated by the necessity of mounting and termination. The uniform mounting, termination and accurate design by Langevin insures the proper component at low cost.

ABOUT SPECIFICATIONS

Langevin reserves the right to make changes in its specifications without notice. This is in the interests of improved performance, lower cost, or both.

ABOUT PRICES

Prices are bound into a separate section of this catalogue. Please write the factory or see your distributor for latest listings.

CSL-1200 SERIES CONTROL CONSOLES



THE CSL-1200 SERIES CONTROL CONSOLES

CSL-1200, FOR VACUUM TUBE AMPLIFIERS

CSL-1201, FOR SOLID STATE AMPLIFIERS

AND

DO IT YOURSELF KITS

MODELS CSL-1200-K & CSL-1201-K

Equivalent Input Noise Almost at Theoretical Limit
Channel Signal-to-Noise Exceeds 78 DB in CSL-1201 and
70 DB in CSL-1200
All Amplifiers Plug-In
Low Impedance Mixing
All Inputs and Outputs Balanced

Single Channel Operation — Monaural
Two Channel Operation — Stereo
Three Channel/Two Channel — Stereo
Illuminated Meters
Color Coded Controls
20 Connected Inputs
Ganged Stereo Mixing Controls

The CSL-1200 Series Control Consoles are new in design and tailored to the requirements of Recording and Broadcasting in Stereo; they are not conversions of monaural consoles. This series is a compact, integrated assembly in a housing of modern design; only the power supply is rack mounted. Amplifiers are miniaturized and plug-in. Dual mixer and monitor controls are utilized to allow proper stereo operation. Placement on the control panel of attenuators, keys and switches is arranged in a functional manner; this arrangement is the result of extensive human engineering and field testing in prominent recording studios and radio stations.

There are a total of ten input positions, augmented through keys and rotary switches to a total of 20 connected sources. Fourteen of the inputs are accompanied by cueing facilities, a must in radio operation. All microphone and auxiliary inputs can be keyed into a left, center and right bus. The center bus feeds the two outside channels to afford "three-channel/two channel" operation, and thus centers the sound from the indi-

vidual inputs chosen for this purpose. Splitting of the center channel is also used in re-recording from three track tape to two track tape for release on disc. All three channels allow dialogue-music equalizers as options.

A stereo-monaural key permits quick transfer from one function to the other. Program amplifiers are interchangeable with limiter amplifiers at the users option, and a key allows the VU meters to be used for reading gain-reduction. A monitor phone jack appears on the side of the console. The outputs of the console are balanced as well as all inputs, including the remote lines and auxiliaries. Quick balance of left and right channels is afforded through a differential dual rotary attenuator which raises one channel and lowers the other channel simultaneously. Especially desirable is the feature of self-contained turntable preamplifiers and the inclusion of equalization for standard magnetic pickup cartridges. Relay wiring is included to operate signal lights and monitor muting.

CSL-1200 SERIES CONTROL CONSOLES

SPECIFICATIONS

GAIN:	Microphone Channels, 98 db (includes 6 db isolation pad) High Level Channels, 53 db Turntable Inputs, 3 mv at 1000 cps drives to full output
FREQUENCY RESPONSE:	± 1 db 20 to 20,000 cps
DISTORTION:	Less than .5% at +30 dbm
SIGNAL-TO-NOISE RATIO:	Better than 78 db (-50 dbm input) for CSL-1201; 70 db for CSL-1200
SOURCE IMPEDANCES:	30 ohms to 600 ohms, balanced, 47 K on phono inputs
ALL LOAD IMPEDANCES:	150 or 600 ohms, balanced
TERMINALS:	Barrier strips internally mounted
CHANNELS:	One, two, or three divided to two for stereo use
ATTENUATORS:	Ten, six individual and two dual types. Two master controls ganged to a common shaft, two monitor controls ganged to a common shaft, and one dual balance control. All are 600 ohm step type units with fine silver contacts and brushes and sealed against noise; no cleaning is required. Total of attenuators is 16; some of which are ganged.
KEYS:	Eight "Cue-Program-Off" Six "A, C, B" channel select One "Stereo, A + B" Two "Gain Reduction" (VU metering) Two "Monitor, Off, Program" Two "Phono, Tape" Two spares Total of Keys is twenty-three
DIALOGUE-MUSIC EQUALIZERS:	Three, one for each channel (optional)
ROTARY SWITCHES:	Total of two to provide choice of four program sources on each of two channels.
HEADPHONE JACKS:	One, for 600 ohm headphone monitoring
REMOTE LINE CUE-BACK:	The remote operator takes his own cue from the program feeding through the console; this is fed back over the remote line.
CONTROL PANELS:	Three sixteenths thick aluminum alloy meter dashboard and main panel, engraved with black fill on Langevin light gray baked-on enamel for truly professional appearance. No escutcheons are employed.

CABINET:

Recesses four inches into Model DSK-12 desk or any table to give standard fifteen degree slope to hinged control panel for comfortable operation. Meter dashboard slopes fifteen degrees from vertical for total height of nine inches above table surfaces; gives full view of studio field. When control panel is opened, entire assembly is exposed for easy servicing in pan only four inches deep. Sturdy, 1/4 inch thick aluminum cowl removes with thumbscrew releases.

DIMENSIONS:

36 inches wide by 13 inches high (4 inches goes below table surface) by 25 1/2 inches deep

MOUNTING:

Model DSK-12, Desk, not supplied

AMPLIFIERS FOR MODEL CSL-1200 (VACUUM TUBE TYPE):

Miniaturized "recording" quality plug-in, push-pull units using etched circuitry. Model AM-5115 amplifier is used for standard magnetic phono-cartridges. Model AM-5116-B (-123 dbm signal-to-noise ratio) serves as preamplifier and booster. Model AM-5117 serves as program amplifier; Model AM-5301 Leveline Limiter-Compressor unit available as direct substitute for AM-5117 program amplifier. Input transformers have 90 db triple mu-metal shield. Inputs and outputs are balanced. Complete specifications on components will be found on succeeding pages.

POWER SUPPLY FOR MODEL CSL-1200:

Rack mounted, Model PS-205-C with silicon rectifiers delivers 425 ma at 300 vdc and 16 a at 6.3 vac

AMPLIFIERS FOR MODEL CSL-1201 (SOLID STATE TYPE):

Miniaturized "recording" quality plug-in, solid state units employing stable silicon transistors. Model AM-16 (-127 dbm signal-to-noise ratio) serves as preamplifier and booster. Model AM-15 phono-cartridge amplifiers for standard magnetic units incorporate accurate equalization. Model AM-17 serves as program amplifier. Model AM-18 limiter-compressor amplifier can be used as a direct substitute for AM-17 program amplifier. Input transformers have 90 db triple mu-metal shields. Inputs and outputs are balanced. Complete specifications on components will be found on succeeding pages.

POWER SUPPLY FOR MODEL CSL-1201:

Rack mounted, plug-in, solid state, 24 volt dc regulated supply with ten ampere capacity, Model PS-217-A. Has sensing circuit to insure 24 volts at amplifier terminals.

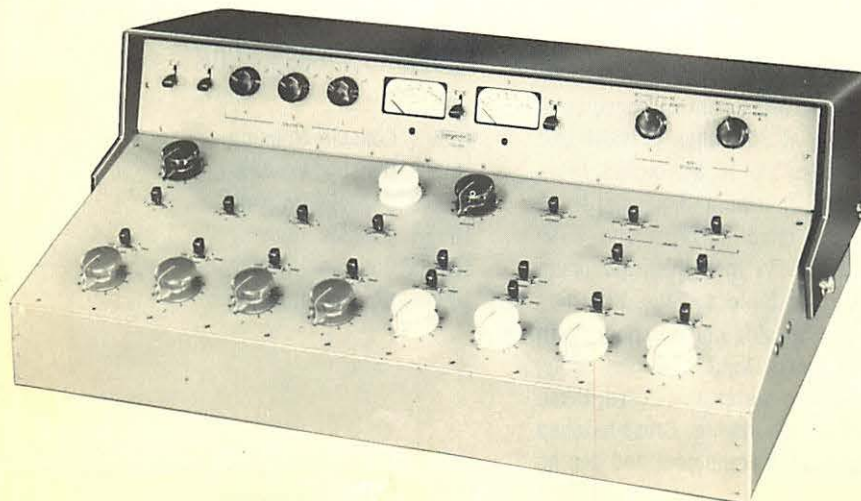

CSL-1200 SERIES CONTROL CONSOLES

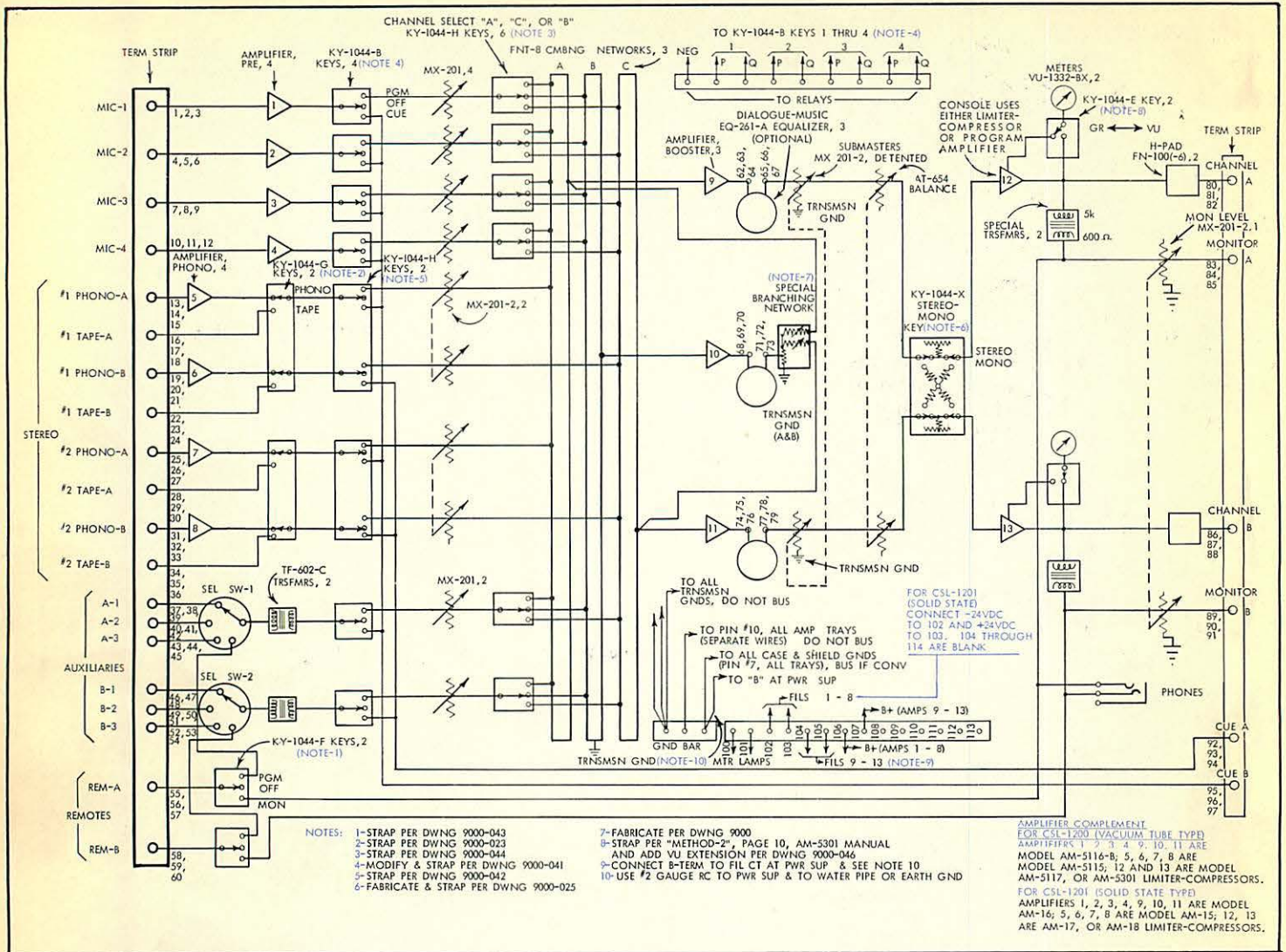

DETAILED SCHEMATIC CIRCUIT

For CSL-1200 Series Control Consoles and Do-It-Yourself Kits

This block schematic, in conjunction with the details on key strapping shown in other pages of this catalogue, provides all the details necessary to the constructor who wishes to duplicate the performance of the CSL-1200 type units. By following the notes carefully the builder may choose either tube or solid state Langevin amplifiers to complement

components he now has.

The Langevin technical service department will be glad to assist the designer, at no charge, in variations to increase and decrease the number and types of inputs to suit individual requirements.

MODEL 1699 SERIES CONSOLE HOUSINGS

The housing shown for the 1200 series control consoles is available as a separate unit starting at 30 inches in width and increasing in increments of 6 inches up to 60 inches total. These housings are uniform in the following dimensions: 13 inches high (4 inches goes below table surface) and 25½ inches deep. The top of the attractive ¼ inch thick aluminum cowl extends only 9 inches above the table surface, affording a clear view of the studio field. The housing comes knock-down and is completely finished in Langevin light and dark gray, except for the hinged control panel and meter dashboard; these are undrilled, and unpainted without engraving. Cross-hatched layout aid shows suggested placement of equipment and depths available over control surface.

ORDERING INFORMATION

MODEL	WIDTH, INCHES
1699-1 Console Housing	30
1699-2 Console Housing	36
1699-3 Console Housing	42
1699-4 Console Housing	48
1699-5 Console Housing	54
1699-6 Console Housing	60

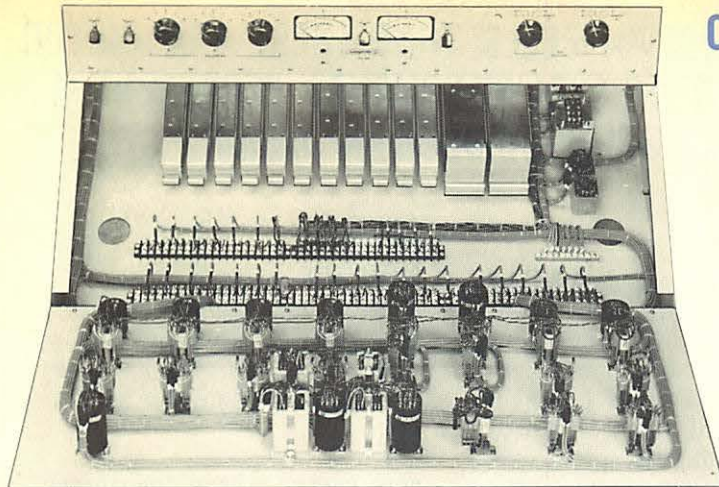

VACUUM TUBE EQUIPMENT

- 1 MODEL CSL-1200 CONTROL CONSOLE**, complete, ready to hook-up and operate; has 7 AM-5116-B tube type preamplifier-booster amplifiers, 4 AM-5115 phono-cartridge amplifiers, 2 AM-5117 program amplifiers, 3 EQ-261 dialogue-music equalizers and 1 PS-205-C power supply for rack mounting. Size is 36 inches wide by 13 inches high (4 inches goes below table surface) by 25½ inches deep. Weight, Net, 225 lbs., Shipping, 260 lbs.

OPTIONS

- 2 MODEL CSL-1200-B CONSOLE**, ready to hook-up and operate as in 1 above, but with circuit modified and 4 phono preamplifiers AM-5115 deleted; suitable for connecting to outputs of conventional 47 K ohm equalized and amplified magnetic phono cartridges.
- 3 MODEL CSL-1200 CONSOLE ONLY**, less 3 Dialogue-Music Equalizers EQ-261, amplifiers and power supply. Plug covers unused mounting holes of equalizers.
- 4 ACCESSORIES FOR CSL-1200 CONSOLE ONLY**
 AM-5115 phono-cartridge amplifiers (4 max.)
 AM-5116-B preamplifier or booster amplifier (7 max.)
 AM-5117 program amplifier (2 max.)
 PS-205-C power supply (1 required)
 AM-5301 limiter-compressor amplifier (optional for program amplifier AM-5117, 2 max.)
 EQ-261 Dialogue-Music Equalizers (3 max.)
 DSK-12 Desk

MODEL CSL-1200-K DO-IT-YOURSELF KIT, consists of all parts as in 3 above, including cable, but is unwired and unassembled. Requires accessories to suit user under 4 above. All metal work is drilled, finished, painted and engraved where appropriate. Full instructions for assembly and cabling are furnished.

SOLID STATE EQUIPMENT

- 1 MODEL CSL-1201 CONTROL CONSOLE**, complete ready to hook-up and operate; with 7 AM-16 solid state preamplifiers, 4 AM-15 phono-cartridge amplifiers, 2 AM-17 program amplifiers, 3 EQ-261 Dialogue-Music Equalizers and 1 Power Supply PS-217-A with rack mounting hardware. Size is 36 inches wide by 13 inches high (4 inches goes below table surface) by 25½ inches deep. Weight, Net, 225 lbs., Shipping, 260 lbs.

OPTIONS

- 2 MODEL CSL-1201-B CONSOLE**, ready to hook-up and operate as in 1 above, but with circuit modified and 4 phono preamplifiers AM-15 deleted; suitable for connecting to outputs of conventional 47 K ohm equalized and amplified magnetic phono cartridges.
- 3 MODEL CSL-1201 CONSOLE ONLY**, less 3 EQ-261 Dialogue-Music Equalizers, amplifiers and power supply. Plug covers unused mounting holes for equalizers.
- 4 ACCESSORIES FOR CSL-1201 CONSOLE ONLY**
 AM-15 amplifier (4 max.)
 AM-16 amplifier (7 max.)
 AM-17 amplifier (2 max.)
 PS-217-A power supply (1 required)
 MF-10-B rack mounting frame for above (1 required)
 TRY-21 tray for power supply (1 required)
 MP-35-A 8¾" mat panel for above (1 required)
 AM-18 limiter-compressor amplifier (optional for program-amplifier AM-17, 2 max.)*
 EQ-261 Dialogue-Music Equalizer (optional, 3 max.)
 DSK-12 Desk

*WATCH FOR RELEASE DATE

MODEL CSL-1201-K DO-IT-YOURSELF KIT, consists of all parts as in 3 above, including cable, but is unwired and unassembled. Requires accessories to suit user as in 4 above. All metal work is drilled, finished, painted and engraved where appropriate. Full instructions for assembly and cabling are furnished.



LANGEVIN FEELS THAT THESE TRANSISTOR AMPLIFIER DEVELOPMENTS REPRESENT A TRUE BREAKTHROUGH IN DESIGN.

GENERAL INFORMATION

The physical and performance requirements for the Langevin transistor amplifiers were established in conjunction with the engineering departments of major national broadcasting networks. These units are designed to exceed the specifications of former Langevin tube type units employed as standard in major broadcasting chains for over 12 years, and to adapt to new needs for smaller size, lower power consumption, less heat dissipation, increased reliability and simplicity in component array.

Langevin has carried its transistor amplifier developments forward on the basis that improvement over tubes was necessary on all counts or there would be no point in offering them. In this development the goals set forth were realized in every category, including unusual success in the reduction of noise approaching the theoretical minimum. This has been accompanied by important advances in stability and long life.

AM-16 AMPLIFIER FOR MOST USES UP TO BUS LEVEL

Complete facilities are offered in the AM-16 amplifier to accomplish the needs of a low-level preamplifier of 45 db gain with +18 dbm capacity, and a booster-program amplifier of 45 db gain with +24 dbm output by simply strapping the tray socket. Thus, interchangeability is effected regardless of function. Special note should be made that usual amplifiers used below bus level have a maximum of +18 dbm power capability; +24 dbm provides 4 times the power handling along with insurance against overload and distortion. This higher output power is a Langevin feature to accommodate to present day recording techniques and closer microphone placement; this is highly important as the circuitry nears bus level.

THE MODEL AM-15 PHONO-CARTRIDGE AMPLIFIERS ALLOW AN INTEGRATED SYSTEM

Employing stable RC circuits for equalization, hum inducing inductors are eliminated. These amplifiers can be console, turntable or rack mounted, and are the same size as the AM-16.

MODEL AM-17 — 8 WATT MONITOR-BRIDGING AMPLIFIER PERMITS COMPLETELY TRANSISTORIZED SYSTEM

The Model AM-17 8 watt monitor-bridging amplifier allows a complete system to be fabricated from microphones to transmitter totally excluding tubes and using only 3 amplifier types. The entire system can be served from a single, regulated 24 volt dc supply.

ETCHED CIRCUITS FOR UNIFORMITY

Performance from one amplifier to another is identical through employment of precision printed circuit techniques on government approved glass epoxy. Etching and other processing conforms to military specifications for dependability and long life. Soldering is contained at component terminations by cup-shaped rivets in accord with requirements for missile and space capsule electronic work.

FEATURES

SMALL SIZE

Twelve AM-16 amplifiers can be employed in a 1 3/4" rack multiple. Units are only 1 1/4 inches wide and 10 1/2 inches deep. Six AM-17 amplifiers use 3 1/2 inches of rack space, and are 2 3/8 inches wide and 10 1/2 inches deep.

GOLD PLATED PLUG-IN CONNECTORS

Rugged gold plated plug-in connectors are utilized for low noise and long, trouble-free life; positive, rugged alignment pins are employed.

ALL AM-16 AMPLIFIERS INTERCHANGEABLE AS PREAMPLIFIER, BOOSTER AMPLIFIER OR PROGRAM AMPLIFIER UP TO BUS LEVEL

Strapping for impedance, gain and reduced output power for lower current drain takes place on the rack cabinet or tray plug socket, allowing all AM-16 amplifiers to be instantly interchangeable for routine test and change of function. This standardization of amplifiers saves in initial system design and gives maintenance economy.

COMPLETE ISOLATION THROUGH NEWLY DEVELOPED TRANSFORMERS

The Langevin transistor amplifiers afford complete isolation through new, highly developed input and output transformers tailored to the requirements of transistors. Balanced hum-bucking design and mu metal shields of special construction are employed to give unusually low hum pickup.

IMPROVED PERFORMANCE OVER TUBE TYPE AMPLIFIERS

These new amplifiers offer far greater stability and longer life along with lower maintenance than that afforded by tube type amplifiers; *this is achieved with increased performance in all categories.*

ECONOMICAL TO USE — LOW INITIAL COST

Simplification of all audio facilities makes possible greater operating economies coupled with low initial cost.

INDIVIDUAL POWER SUPPLY FOR EACH AMPLIFIER NOT REQUIRED

Multiple, costly integrated power supplies are not required because of the circuit of these amplifiers. One economical common power supply can serve an entire system. Induced hum problems are under complete control at one source.

ONLY THE SUPERIOR SILICON TRANSISTORS ARE EMPLOYED. LESS STABLE, LOWER COST GERMANIUM TRANSISTORS ARE NOT PERMITTED!

Only highly developed transistors of the silicon type are employed for stability, long life and low noise; absolutely no germanium units are used, hence, there is no derating of the amplifier output with increasing temperature above the room ambient. Absolute stability up to 65°C (145°F).

MODEL AM-16 TRANSISTOR AMPLIFIERS

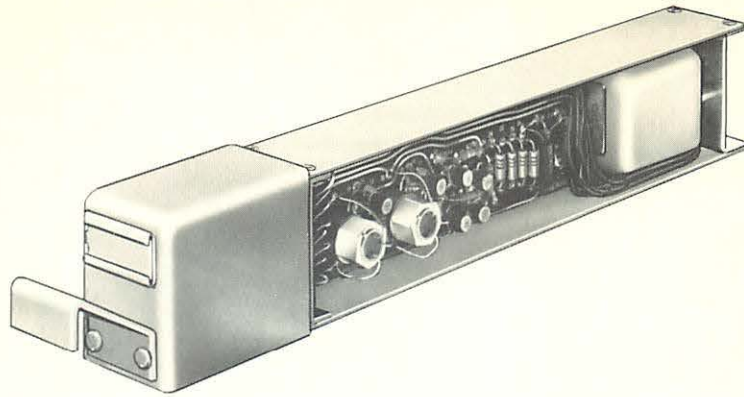

MODEL AM-16 TRANSISTOR AMPLIFIER FOR USE UP TO BUS LEVEL PREAMPLIFIER, BOOSTER AMPLIFIER OR PROGRAM AMPLIFIER

The AM-16 amplifier is the successful result of vigorous research in the field of solid state devices by Langevin physicists and scientists. Employment of superior, stable silicon transistors in a new application of direct coupled circuitry gives low noise characteristics approaching theoretical minimum. Low heat dissipation, small size, long life (no electrolytic capacitors

are employed) reliability and low power consumption, all contribute to performance exceeding the best tube type amplifiers.

The AM-16 amplifier allows amplifier components up to bus level to be interchangeable. The gain of 45 db allows it to be employed for normal microphone input levels of -60 dbm, or as a booster or a program amplifier.

AM-16 PREAMPLIFIER — BOOSTER & PROGRAM AMPLIFIER

ELECTRICAL CHARACTERISTICS

GAIN:	45 db; maximum signal input — 21 dbm	
INPUT SOURCE IMPEDANCE:	37.5, 150 or 600 ohms, balanced or unbalanced. Center tap on 150 and 600 ohms.	
OUTPUT LOAD IMPEDANCE:	150 or 600 ohms, balanced or unbalanced. Center tap on 600 ohms	
DISTORTION:	.15% at 1 kc at +18 dbm; .25% at 1 kc at +24 dbm. Less than .5% total harmonic distortion from 30-20,000 cps at +18 dbm; less than .75% from 30-20,000 cps at +24 dbm	
OUTPUT NOISE:	Unweighted, equivalent to an input signal of -127 dbm over the entire pass band of the amplifier	
FREQUENCY CHARACTERISTIC:	±.5 db 20-20 kcps; down 6 db at 40 kcps at +24 dbm	
TRANSISTOR COMPLEMENT:	No.	Type Use
	2	2N-929 Input Stage
	2	NS-734 Intermediate Stage
	2	NS-734 Driver Stage
	2	TI-487 Output Stage
POWER REQUIREMENTS:	When tray plug receptacle is strapped for output power of:	Current drain at 24 vdc
	+18 dbm	50 ma
	+24 dbm	110 ma
OPERATING CONDITIONS:	Maximum cabinet temperature, continuous duty cycle, without derating: 65°C (145°F) Heat Dissipation Strapped for:	
	+24 dbm output, less than 3 watts	
	+18 dbm output, less than 2 watts	
ELECTRICAL CONNECTIONS:	Connections are made to the amplifier through an 18 pin gold plated connector, Viking Model VT-18/PMG	
CIRCUIT:	4 stage push-pull, direct coupled	
SIZE:	1¼ in. w, 1¾ in. h by 10½ in. d overall	
FINISH:	Light gray baked enamel and cadmium plate iridized	

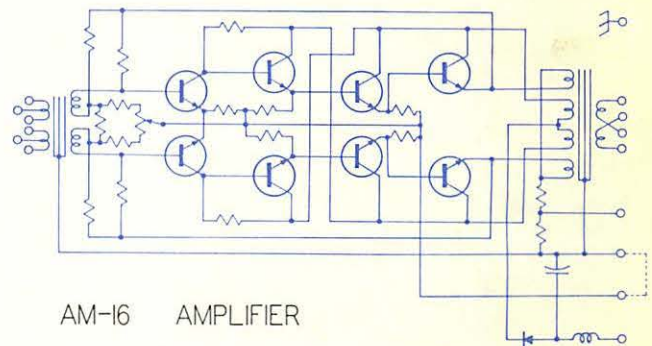

AM-16 AMPLIFIER

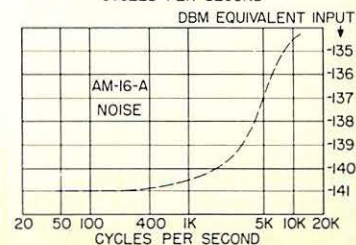
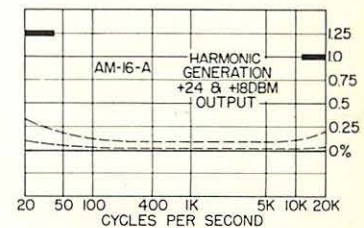
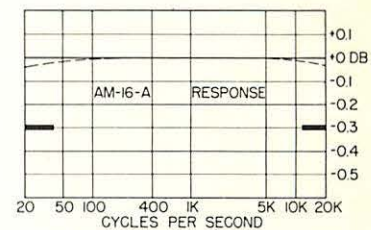

MODEL AM-17 TRANSISTOR AMPLIFIER

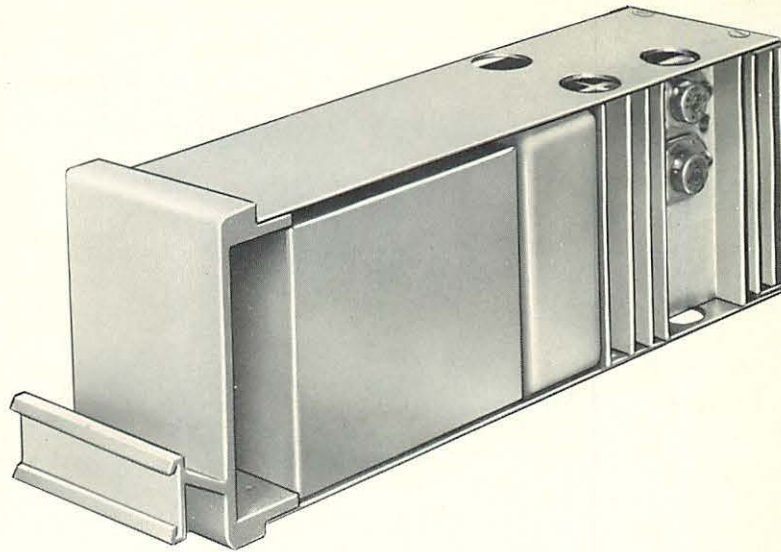

AM-17 MONITOR — BRIDGING AMPLIFIER

Features

- Direct Coupled Circuitry for High Efficiency**
- Long, Trouble-Free Life — No electrolytic condensers employed**
- Versatile — 8 watt output with strap for 1 watt**
- Compact — Six units fit in 3½ inch rack multiple**

The AM-17 is a plug-in, versatile and compact amplifier using transistors. It delivers 8 watts as a monitor, and when strapped for lower output of +30 dbm serves as a line or program amplifier. When used in conjunction with the AM-15 and AM-16 lower level units, it permits an entire system to be designed from microphone to transmitter utilizing only three types of amplifiers, all of which may be served from a common 24 volt dc supply. Six AM-17 amplifiers use only 3½ inches of rack space, and Model TRY-7 individual trays allow incorporation within the console housing if desired.

ELECTRICAL SPECIFICATIONS

- GAIN:** 56 db
- OUTPUT POWER:** +39 dbm, or 8 watts; strap available for +30 dbm, or 1 watt
- INPUT SOURCE IMPEDANCE:** 37.5, 150 or 600 ohms, balanced or unbalanced; 150 and 600 ohms center tapped
- OUTPUT LOAD IMPEDANCE:** 150 or 600 ohms, balanced or unbalanced; 600 ohms center tapped
- DISTORTION:** .15% at 1 kc at 8 watts. Less than .5% total harmonic distortion 30-20 kcps at 1 watt; less than 1% total harmonic distortion 30-20 kcps at 8 watts
- OUTPUT NOISE:** Unweighted, equivalent to an input signal of -115 dbm over the entire pass band of the amplifier
- FREQUENCY CHARACTERISTIC:** ±.5 db 20-20 kcps
- TRANSISTOR COMPLEMENT:**
- | No. | Type | Use |
|-----|--------|--------------------|
| 2 | NS-734 | Input Stage |
| 4 | NS-734 | Intermediate Stage |
| 2 | T1-487 | Driver Stage |
| 4 | 2N1701 | Output Stage |
- POWER REQUIREMENTS:**
- | When tray plug receptable is strapped for: | Current drain at 24 vdc |
|--|-------------------------|
| +30 dbm (1 watt) | 1 a |
| +39 dbm (8 watts) | 2 a |
- OPERATING CONDITIONS:** Maximum cabinet temperature, continuous duty cycle, without derating: 65°C (145°F)
Heat dissipation for +39 dbm (8 watts) output: 48W
Heat dissipation for +30 dbm (1 watt) output: 24W
- ELECTRICAL CONNECTIONS:** All connections are made to the amplifier through an 18 pin gold plated connector, Viking Model VT-18/PMG
- CIRCUIT:** 4 stage push-pull, direct coupled
- SIZE:** 2½ ins. w, 3½ ins. h (fits 3½ in. rack-multiple) by 10½ ins. d overall
- FINISH:** Light gray baked-on enamel and cadmium plate iridited

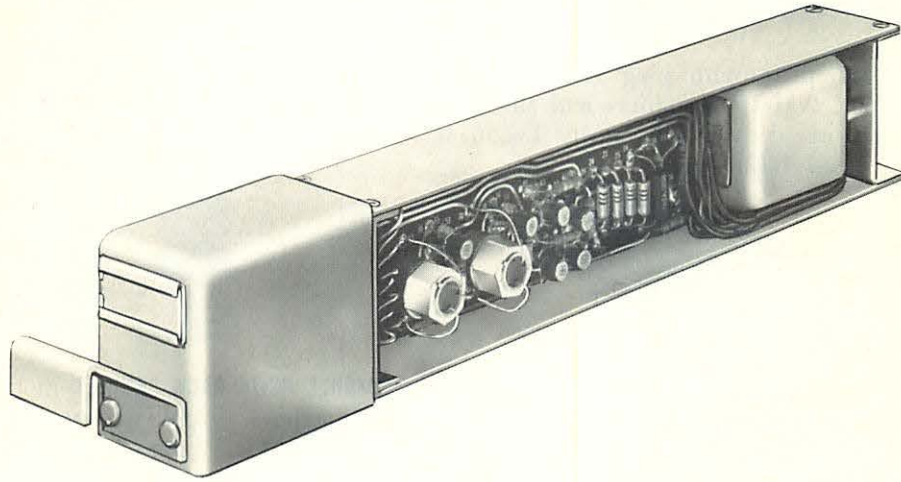
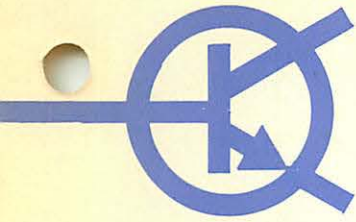

AM-15 PHONO-CARTRIDGE AMPLIFIER

ELECTRICAL CHARACTERISTICS

GAIN:	10 mv input at 1000 cps produces +4 dbm output level.															
INPUT SOURCE:	Any conventional monaural or stereo magnetic phono-cartridge.															
OUTPUT LOAD IMPEDANCE:	150 or 600 ohms, balanced or unbalanced. Center tap on 600 ohms															
DISTORTION:	.25% total harmonic distortion at +12 dbm at 1000 cps. Less than 1% total harmonic distortion 20-20,000 cps															
OUTPUT NOISE:	Unweighted, equivalent to an input signal of -127 dbm over the entire pass band of the amplifier. 70 db signal-to-noise															
FREQUENCY CHARACTERISTICS:	RIAA Standard, ± 1 db 20-20,000 cps.															
TRANSISTOR COMPLEMENT:	<table border="0"> <tr> <td>No.</td> <td>Type</td> <td>Use</td> </tr> <tr> <td>2</td> <td>2N-929</td> <td>Input Stage</td> </tr> <tr> <td>4</td> <td>NS-734</td> <td>Intermediate Stage</td> </tr> <tr> <td>2</td> <td>NS-734</td> <td>Driver Stage</td> </tr> <tr> <td>2</td> <td>NS-734</td> <td>Output Stage</td> </tr> </table>	No.	Type	Use	2	2N-929	Input Stage	4	NS-734	Intermediate Stage	2	NS-734	Driver Stage	2	NS-734	Output Stage
No.	Type	Use														
2	2N-929	Input Stage														
4	NS-734	Intermediate Stage														
2	NS-734	Driver Stage														
2	NS-734	Output Stage														
POWER REQUIREMENTS:	24 vdc at 40 ma															
OPERATING CONDITIONS:	Maximum cabinet temperature, continuous duty cycle, without derating: 65°C (145°F) Heat dissipation less than 1 watt															
ELECTRICAL CONNECTIONS:	All connections are made to the amplifier through an 18 pin gold plated connector, Viking Model VT-18/PMG															
CIRCUIT:	5 stage push-pull															
SIZE:	1¼ in. w, 1¾ in. h by 10½ in. d overall.															
FINISH:	Light gray baked enameled and cadmium plate iridited															

Features

- Good signal-to-noise**
- Low Power Consumption**
- Accurate RIAA Curve Characteristic**
- Turntable, Console or Rack Mount**
- Low Distortion at Maximum Output of +4 dbm**

This phono-cartridge amplifier is plug-in and has an input load impedance of 47000 ohms. This impedance enables the use of virtually all magnetic stereo and monophonic cartridges, including the Pickering 90 and 380, Shure M7D, GE VR1000 and the Fairchild SM-1.

Unusual attention has been given to achieving accurate equalization to the RIAA curve characteristic. No hum inducing inductors are employed; only stable RC circuits are used. The capacitors are of the superior mylar type.

Mounting arrangements are flexible. Individual trays, Model TRY-6 allow placement inside the console or in the turntable. In turntable mounting Model PS-219-A power supply with 110 ma capacity can handle to 6 individual AM-15.

ORDERING INFORMATION TRANSISTOR AMPLIFIERS

MODEL AM-15 AMPLIFIER, complete with transistors. Plug receptacle not furnished. Weight, Net, 1 lb 7 ozs, 2 lbs. shipping

MODEL AM-16 AMPLIFIER, complete with transistors. Plug receptacle not furnished. Weight, Net, 1 lb. 6 ozs, 2 lbs. shipping

MODEL TRY-6 TRAY, complete with plug receptacle for single AM-15 and AM-16 amplifiers and all hardware. Size: 11¼ ins. d by 1⅞ in. w by 1⅞ in. h Weight, Net, 6 ozs, 1 lb shipping

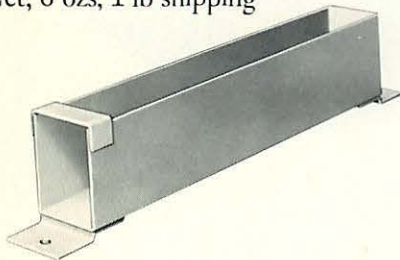

MODEL AM-17 AMPLIFIER, complete with transistors. Plug receptacle not furnished. Weight, Net, 4½ lbs, 6 lbs shipping

MODEL TRY-7 MOUNTING TRAY, for single AM-17 amplifier, complete with plug receptacle and mounting hardware. Size: 11¼ ins. d by 2¾ ins. w by 3⅞ ins. h Weight, Net, 9 ozs, 1½ lbs. shpg.

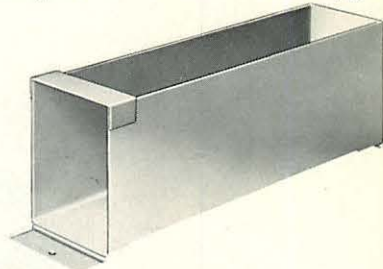

MODEL RC-612 RACK CABINET, mounts 12 AM-15 or AM-16 amplifiers as well as PS-219-A power supplies in any combination. Includes all plug receptacles and has integral trays. Height is 1¾ in. rack multiple. Width over standard WE notched 3/16 in. thick aluminum mounting ears is 19 ins. Inside rack width is 16 ins. Vertical members are sturdy ½ in. thick aluminum. Exposed surfaces are baked-on light gray enamel to match amplifiers and other Langevin equipment. Individual guides are provided for each amplifier; retaining plate on top secures all amplifiers but allows maximum ventilation while acting as heat sink. Weight, Net, 6 lbs, 9 lbs shpg.

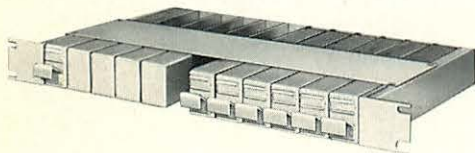

MODEL RC-76 RACK CABINET, mounts 6 AM-17 amplifiers; includes all plug receptacles and has integral trays. Height is 3½ in. rack multiple. Width over 3/16 in. thick aluminum mounting ears is 19 ins. Inside rack width is 16 ins. Vertical members are sturdy ½ in. thick aluminum. Exposed surfaces are light gray baked-on enamel to match AM-17 and other Langevin equipment. Individual guides are provided for each amplifier; retaining plate on top secures all amplifiers but allows maximum ventilation while acting as heat sink.

Weight, Net, 9 lbs, 12 lbs shpg.

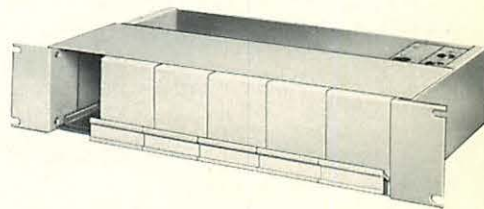

MODEL MP-16 APPARATUS BLANK, uses space of 1 AM-15 or AM-16 amplifier in RC-612 rack cabinet. Preserves neat appearance when less than 12 amplifiers are used.

Weight, Net, 2 ozs, ½ lb shipping

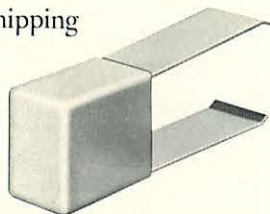

MODEL MP-17 APPARATUS BLANK, uses space of 1 AM-17 amplifier in RC-76 rack cabinet. Preserves neat appearance when less than 6 AM-17 amplifiers are used. Weight, Net, 3 ozs, 1 lb shpg.

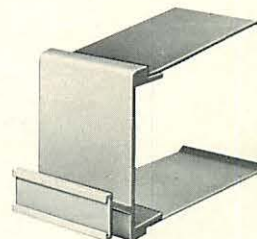

RACK MOUNTING ACCESSORIES:

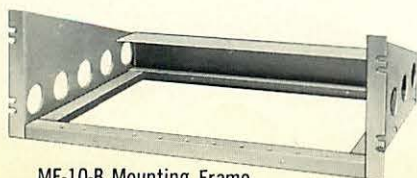

MF-10-B Mounting Frame

MOUNTING:



Model TRY-21 Tray

TRANSISTOR AMPLIFIER POWER SUPPLIES

MODEL PS-217-A, PS-218-A AND PS-219-A POWER SUPPLIES

GENERAL

The Models PS-217-A, PS-218-A and PS-219-A 24 volt dc power supplies deliver 10, 3 and 11 amperes respectively. They have been especially designed to complement the Langevin low-level and monitor-level transistor amplifiers. All units have plug-in feature and fit mounting trays which come with mating sockets. Rack mounting facilities are available.

FEATURES

NEW TRANSFORMER DESIGN MINIMIZES HUM FIELD

Power transformers utilize bi-filar windings and hum-bucking construction; units are oversize to run cool. Alkanex wire employed is guaranteed for 80,000 hours at 180° Centigrade.

REGULATION FOR CONSTANT VOLTAGE

Uniform voltage output is guaranteed under varying conditions of line voltage and current drain through regulation feature. Application of 70% of the full load causes only a 20 millivolt transient. A special sensing circuit allows sampling at amplifier terminals to insure 24 volts (except PS-219-A).

LOW RIPPLE FOR HUM-FREE PERFORMANCE

Less than 1 millivolt of ripple is evidenced at maximum load on all models.

HEAVY, RUGGED CONSTRUCTION FOR YEAR IN, YEAR OUT DUTY CYCLE

These power supplies are designed to give hum-free, stable performance with low heat rise through continuous, maintenance-free use over many years of service.

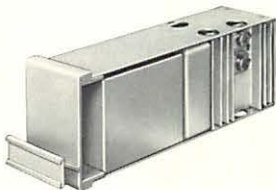
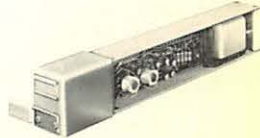
SPECIFICATIONS			
MODEL	PS-217-A	PS-218-A	PS-219-A
INPUT:	105-125 vac and 210-250 vac 50/60 cps	105-125 vac and 210-250 vac 50/60 cps	105-125 vac and 210-250 vac 50/60 cps
DC OUTPUT:	10 amperes max. at 24 vdc, regulated	3 amperes max. at 24 vdc, regulated	110 ma max. at 24 vdc
OUTPUT RIPPLE:	Less than 1 millivolt at full load	Less than 1 millivolt at full load	Less than 1 millivolt at full load
RECTIFIER COMPLEMENT:	2 ea. IN 3210 silicon diodes 4 ea. IN 2069 silicon	2 ea. IN 3210 silicon diodes 2 ea. IN 2069 silicon	4 ea. IN 2069 silicon diodes
POWER CONSUMPTION:	300 watts	90 watts	7 watts
REGULATOR COMPLEMENT:	1 2N2156 1 2N1545 4 2N650 2 IN 3022B	1 2N2156 1 2N1545 2 2N650 1 IN716	2 TI-487 1 IN723
SIZE:	Width: 14 ins. Height: 7¾ ins. Depth: 11 ins.	2¾ ins. 3½ ins. 10½ ins.	1¼ ins. 1¾ ins. 10½ ins.
NET WEIGHT:	50 lbs	6 lbs	1 lb 8 ozs
SHIPPING WEIGHT:	60 lbs	8 lbs	2 lbs
FINISH:	Light gray baked enamel over 16 gauge bonderized (rustproofed) steel	Light gray baked enamel and cadmium iridited	Light gray baked enamel and cadmium iridited
MOUNTING:	Model TRY-21 Tray with female plug-in receptacle	Model TRY-7 Tray with female plug-in receptacle	Model TRY-6 Tray with female plug-in receptacle
RACK MOUNTING ACCESSORIES:	MF-10-B Mounting Frame MP-35-A Mat Panel (8¾ in. multiple)	RC-76 Rack Cabinet (takes 6 AM-17 ampli- fiers and PS-218-A in any combination)	RC-612 Rack Cabinet (takes 12 AM-15 and AM-16 amplifiers or PS-219-A in any combination)

NEW MODEL AM-5115 PHONO-CARTRIDGE AMPLIFIER

MODEL AM-5116-B FOR USE UP TO BUS LEVEL

PRE-AMPLIFIER, BOOSTER AMPLIFIER OR PROGRAM AMPLIFIER

MAXIMUM GAIN: 46 db, -70db input
to +24 dbm output with one amplifier.

NOISE LEVEL: -123 dbm

PRINTED CIRCUITS, MINIATURIZED TRANSFORMERS

The AM-5116-B Amplifier allows all amplifier components up to bus level to be completely interchangeable. The high gain of 46 db allows it to be employed in insensitive microphone circuits, normal microphone input levels of -55 db, as a booster or a program amplifier, all by simply strapping the proper load resistor or resistors on the Model TRY-5016 Tray plug socket.

THIS ALLOWS INSTANT AND COMPLETE INTERCHANGEABILITY FOR ALL FUNCTIONS BELOW BUS LEVEL WITHOUT RESTRAPPING THE INPUT AND OUTPUT TRANSFORMERS.

Tube metering facilities consisting of push-buttons allow measurement of each tube while the amplifier is in service. Langevin Model MTR-506 Tube Check Meter is available for this use.

PRINTED CIRCUITS FOR UNIFORMITY

Performance from one Model AM-5116-B Amplifier to another is identical through the employment of precision printed circuit techniques. Glass epoxy forms the printed circuit base and is one eighth inch thick for rigidity and strength. Etching and other processing conforms to military specifications for dependability and long life. Solder is contained at component terminations by cup-shaped rivets in accord with the requirements for missile electronic work.

Because the interconductor capacitance is almost non-existent, no difference in noise level between ac and dc can be discerned when used on the heater circuits.

MECHANICAL SPECIFICATIONS:

Size: Length 9 in., width 1 3/8 in., height 3 1/8 in.
Weight: 1 lb., 2 ounces net; 1 1/2 lbs. shipping.
Finish: Light gray baked enamel over 18 gauge bonderized (rustproofed) steel.

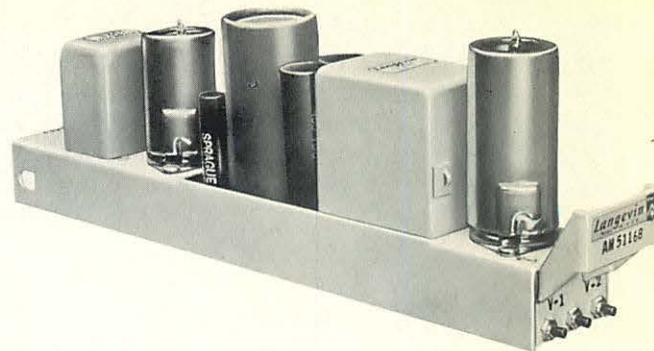

ELECTRICAL CHARACTERISTICS

PHASE SHIFT: Less than 18 degrees from 20 to 20,000 cps.

POWER REQUIREMENTS: Plate 300 Volts dc; 25 ma for output power of +24 dbm, 12 ma for power of +18 dbm (strap removed).

FILAMENT: 6.3 Volts at .9 amperes ac or dc.

TUBE COMPLEMENT: 1 type 12AX7, select, (Langevin Model TUS-12AX7) and 1 type 12BH7. (Langevin TU-12BH7)

DUTY CYCLE: Continuous.

GAIN: Unloaded Input:	46 db	Maximum Signal Input:	-20 dbm
	40 db		-10 dbm
	35 db		- 5 dbm

With 600 ohm input	42 db	-16 dbm
	36 db	-10 dbm
	31 db	- 5 dbm

INPUT SOURCE IMPEDANCE: Matches all sources; see chart on page 15 for proper resistor or loading.

OUTPUT LOAD IMPEDANCE: To work into 50, 150, 200, 250, 500 or 600 ohms, balanced and floating.

DISTORTION: .2% at 1000 cps at +24 dbm with IM at 1%.

OUTPUT POWER: +24 dbm over the range 20 to 20,000 cps at less than .5% distortion, with 1% distortion at 20 cps.

OUTPUT NOISE: Unweighted, equivalent to an input signal of -123 dbm, tubes supplied with ac on heaters. Selected 12AX7 1st stage (Langevin TUS-12AX7) average 12BH7 2nd Stage.

FREQUENCY CHARACTERISTIC: ±0.5 db at 20 and 20,000 cps at any level up to +24 dbm.

ORDERING INFORMATION

MODEL AM-5116-B AMPLIFIER, includes tubes and is strapped 600 ohms in and out.

MODEL AM-5115 PHONO-CARTRIDGE AMPLIFIER, same as AM-5116-B amplifier but equalized for RIAA curve characteristic and input arranged for standard 47K ohm magnetic cartridges.

MODEL TRY-5016 TRAY for above, with plug socket complete,

APPLICATION OF NOVA AMPLIFIERS

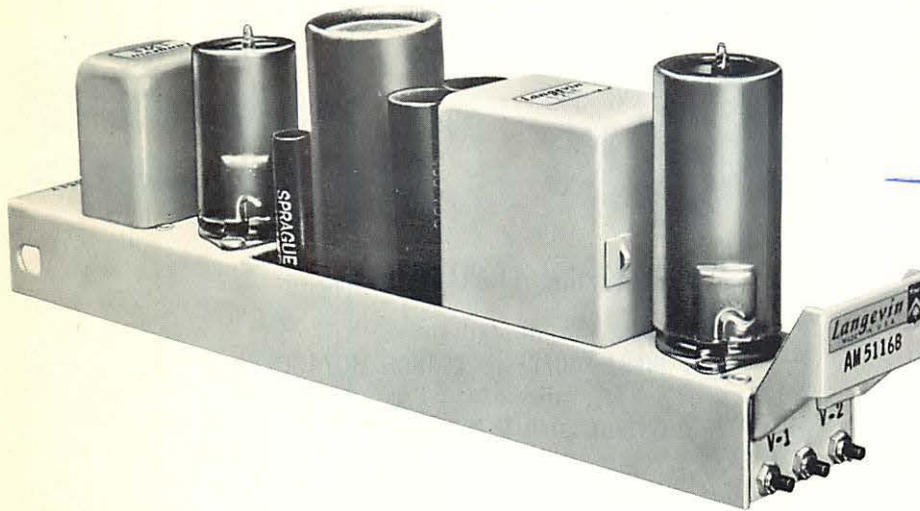

AM-5116-B

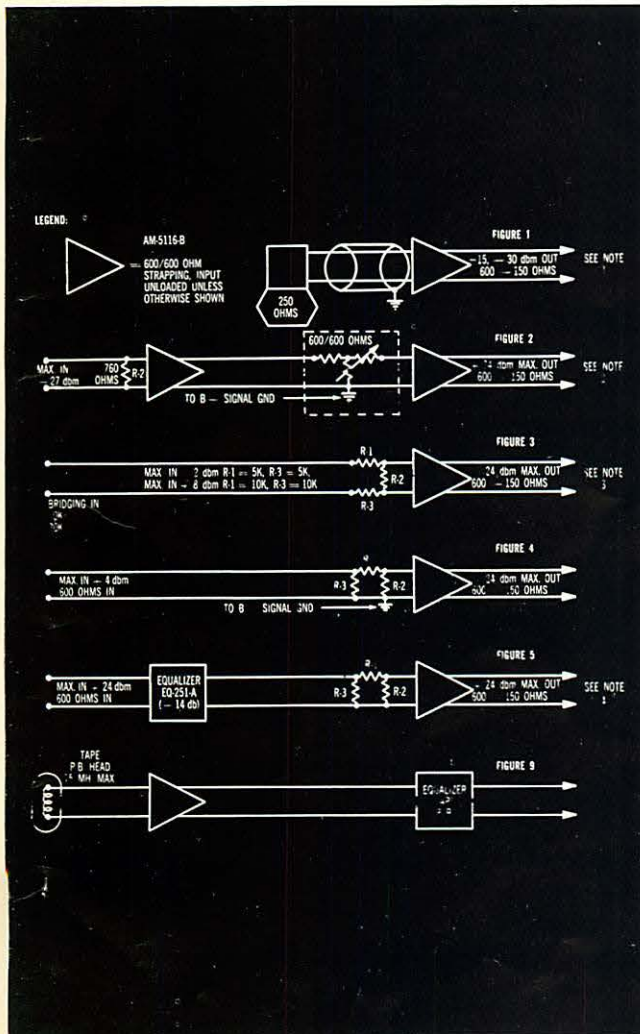
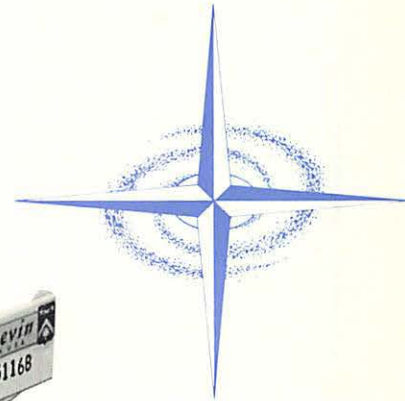

PURPOSE	FIGURE	R-1	R-2	R-3	GAIN in db	REMARKS
MICROPHONE PREAMPLIFIER	1	—	—	—	46	EFFECTIVE GAIN OVERALL, MICROPHONE TO AMPLIFIER OUTPUT. SEE NOTE 1.
STRAPPED: 50 OHMS	1	—	—	—	46	
150 OHMS	1	—	—	—	46	
HIGH GAIN LINE AMPLIFIER WITH CONTROL	2	600/600 LADDER e.g., MX-201, MX-III etc.			76	SEE NOTE 2
BRIDGING AMPLIFIER	3	5K	800	5K	22	SEE NOTE 3.
BRIDGING AMPLIFIER	3	10K	800	10K	16	
BOOSTER AMPLIFIER	4	10K	800	620	16	
BOOSTER AMPLIFIER	4	8K	800	700	20	
LINE AMPLIFIER	2	—	760	—	41	
EQUALIZER BOOSTER	5	4K	760	760	0	SEE NOTE 4.
TAPE HEAD PRE-AMP AND EQUALIZER	9	—	—	—	26	

NOTES

- NOTE 1. RECOMMENDED PRACTICE IS TO OPERATE MICROPHONE AMPLIFIER WITH UNLOADED INPUT FOR HIGHEST GAIN AND BEST SIGNAL TO NOISE.
- NOTE 2. CONTROLS EMPLOYING T CIRCUIT MUST HAVE COMMON TERMINAL TIED TO SIGNAL GROUND OR "B-" OF AMPLIFIER TO ALLOW COMPLETE GAIN CUT-OFF. NOT REQUIRED FOR H CIRCUITS. ADD 6 db GAIN FOR T AND H CONTROLS.
- NOTE 3. R-2 CAN BE MADE VARIABLE IF GAIN CONTROL IS DESIRED.
- NOTE 4. ADDED 10 db GAIN AVAILABLE IF R-1 AND R-3 ARE DELETED WITH ONLY R-2 REMAINING.

The circuit arrangements shown above will be helpful in suggesting a wide variety of uses for Langevin's Model AM-5116-B General Purpose Amplifier.

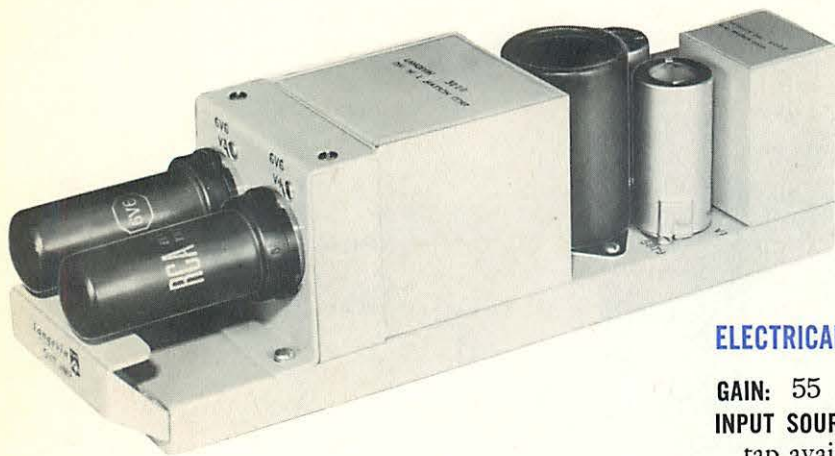

MODEL AM-5117 PROGRAM BOOSTER OR MONITOR AMPLIFIER

ELECTRICAL CHARACTERISTICS

GAIN: 55 db.

INPUT SOURCE IMPEDANCE: 30/150/600 ohms. Center tap available when connected for 150 or 600 ohms.

OUTPUT LOAD IMPEDANCE: 150 or 600 ohms. Center tap available when using 600 ohm connection.

OUTPUT POWER: As a Program Amplifier, +26 dbm (0.40 watts) with less than 0.5% rms total harmonic distortion over the range 50 to 15,000 cps.

OUTPUT POWER: As a Monitor Amplifier, +39 dbm (8 watts) with less than 1% rms total harmonic distortion over the range 50 to 15,000 cps.

OUTPUT NOISE: Unweighted, equivalent to an input signal of -110 dbm or less, depending upon tubes, over the band 30 to 15,000 cps.

FREQUENCY CHARACTERISTICS: ± 0.5 db, 30 to 15,000 cps.

POWER REQUIREMENTS: Plate: 300 volts dc. As Program Amplifier: 35 ma; as Monitor Amplifier: 75 ma. Filament: 6.3 volts 1.2 amps dc or ac.

TUBE COMPLEMENT: 2 Type 5879 miniature.
2 Type 6V6 Octal Base. (6V6GT optional)

DUTY CYCLE: Continuous.

MECHANICAL SPECIFICATIONS

SIZE: Length 10½ in., width 2¾ in., height 3 in.

WEIGHT: 4 pounds net, 5 pounds shipping.

FINISH: Light gray baked enamel over 18 gauge bonderized (rustproofed) steel.

MOUNTING TRAY: Langevin Model TRY-5017.

ORDERING INFORMATION

MODEL AM-5117 AMPLIFIER, includes tubes and is strapped for 600 ohms in and out.

MODEL TK-5117 TUBE KIT for above, consists of 2 each type 5879 and 2 each type 6V6 metal tubes.

MODEL AM-5117 AMPLIFIER LESS TUBES, same as model AM-5117, but less tubes.

MODEL TRY-5017 TRAY for above, with plug socket complete.

MODEL MTR-506 TUBE CHECK METER

The Langevin Model AM-5117 amplifier is a MINIATURE PLUG-IN three-stage, push-pull, fixed gain audio amplifier designed specifically for use in radio and television broadcast audio systems, recording studios and sound systems. Undoubtedly the most compact 8-watt audio amplifier yet developed, its quality is unmatched. It has many applications where outstanding performance and maximum flexibility are required.

Like the Model AM-5116 amplifier, push-button metering facilities are provided in the model AM-5117 amplifier. A gold plated miniature plug permits rapid installation, removal and replacement of these tiny amplifiers.

SPECIAL FEATURES

A low B + drain of only 35 ma., 300 volts dc when used as a program Amplifier reduces power supply requirements. This is accomplished by unstrapping 2 pins on the tray receptacle. When pins are strapped for use as a Monitor Amplifier, the unit draws 75 ma, 300 volts dc. The amplifiers are identical for either service.

The 6V6 tubes are replaceable without unplugging the amplifier. Excellent cooling, offered by the location of the 6V6 tubes, makes more compact installations possible.

PLUG IN BROADCAST AMPLIFIERS

THE 5000 SERIES RACK MOUNTING DETAILS

Complete mounting accessories are available for the 5000 Series. They consist of the Models TRY-5016 and TRY-5017 Mounting Trays for the Models AM-5116-B and AM-5117 Amplifiers; Models TRY-5017 and TRY-5019 Mounting Trays for the Models PS-5208-A and PS-5206 power supplies respectively.

The rack mounting assembly for the miniature plug-in in 5000 Series is the Model MF-5010 Mounting Frame which occupies only 3½" of standard equipment rack space. This frame can accommodate various combinations of the 5000 Series as shown below.

REMOVABLE MOUNTING TRAYS

All mounting trays are supplied with gold-plated receptacles for mating with the plug on the amplifier or power supply. In addition, all mounting trays are provided with a locking clip to prevent upward lift of the unit until plug is disengaged. Grounded tabs are provided to assure positive electrical ground.

The model MF-5010 Mounting Frame allows tray installation from the front or back of the rack. The PLUG-IN Model FP-5032 Front Panel is available as a front cover for the MF-5010 Frame.

In the illustration above, trays are mounted for a combination of three pre-amplifiers AM-5116 or AM-5116-B, one program amplifier AM-5117, or Leveline AM-5301 and one PS-5208-A power supply.

CONSTRUCTION

All mounting trays are made of 18 gauge steel with light gray baked enamel finish. The Model MF-5010 Frame combines heavy 14 gauge side brackets firmly welded to a 16 gauge rigidized metal base, both finished with light gray baked enamel.

CABLING

Cabling may be run in the space adjacent to the plug receptacles, either at the front or rear of the MF-5010 Frame. Complete accessibility for wiring to receptacle pins is offered by recessed tray and frame construction.

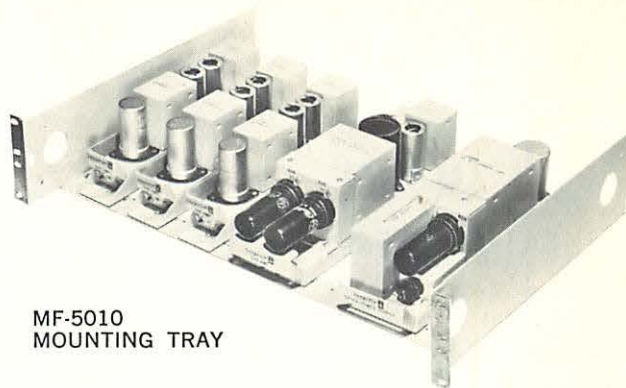

MF-5010 MOUNTING TRAY

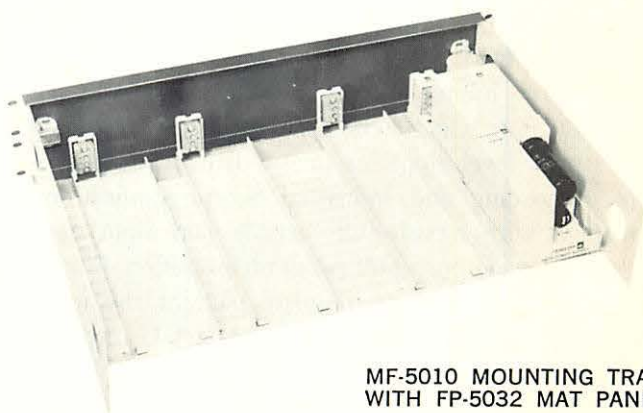

MF-5010 MOUNTING TRAY WITH FP-5032 MAT PANEL

POSSIBLE TRAY COMBINATIONS ON A MODEL MF-5010 MOUNTING FRAME

TRY-5016 TRAY	TRY-5017 TRAY	TRY-5019 TRAY
11	0	0
0	6	0
0	0	2
9	1	0
7	2	0
5	3	0
3	4	0
1	5	0
0	3	1

GENERAL SPECIFICATIONS AND ORDERING INFORMATION

					
	MODEL TRY-5016 MTG. TRAY	MODEL TRY-5017 MTG. TRAY	MODEL TRY-5019 MTG. TRAY	MODEL MF-5010 MTG. FRAME	MODEL FP-5032 FRONT PANEL
FOR USE WITH	AM-5116 AM-5116-B	AM-5117, AM-5301 PS-5208-A	PS-5206	TRY-5016 TRY-5017 TRY-5019	MF-5010
DEPTH	9¾"	9¾"	9¾"	13"	
WIDTH	1-1½"	2¾"	7⅞"	19"	19"
HEIGHT	2⅞"	1⅞"	1¾"	3⅞"	3⅞"
WEIGHT	6 oz.	7½ oz.	1 lb. 1 oz.	4 lb. 14 oz.	11 lb. 8 oz.
SHIPPING WEIGHT	1 lb.	2 lbs.	2 lbs.	6 lbs.	13 lbs.

THE MODEL AM-5301 LEVELINE AMPLIFIER

+ 37 dbm OUTPUT (6 WATTS)

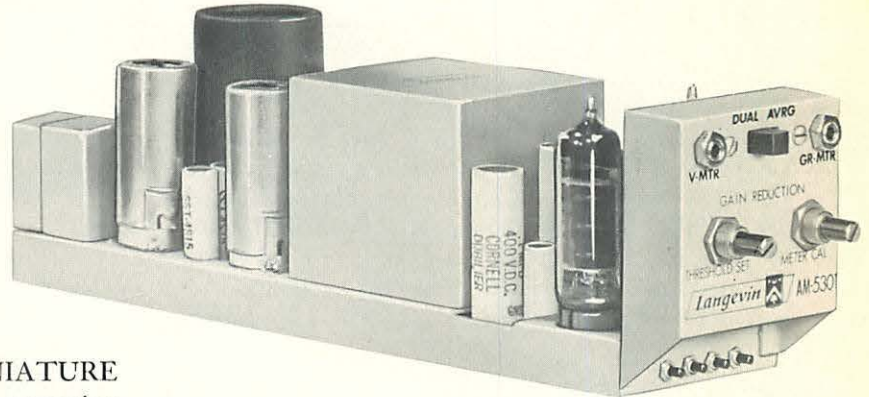

INTRODUCTION

This new limiter amplifier is a MINIATURE PLUG-IN unit which acts as an automatic averaging or as a peak level amplifier in TV-Broadcast, Microwave, Recording and Industrial Sound applications. It operates with a push-pull variable gain input stage driving a 2 stage push-pull program amplifier. Silicon rectifiers provide bias to regulate gain of the input stage. Decals are furnished to convert a VU meter to a Gain Reduction Meter.

Maximum program variations up to 30 db can be controlled, thus relieving studio personnel of many exacting level adjustments. In recording, this unit allows higher signal-to-noise ratios by loading the tape or disc; thus the engineer is not required to anticipate overloads. This anticipation results in lower signal to noise and lower maximum levels than those otherwise possible. The unit is equipped with a chassis control to set limiting and compressing action, along with a metering jack.

For recording use, accessories are available which include an extension bias meter and a threshold control, allowing continuously variable control of limiting during the program with console panel accessibility.

APPLICATIONS

EXPANDER-COMPRESSOR - With an average program material level sufficient to produce 15 db of gain reduction, the output signal will be compressed for incoming signals exceeding 15 db, and expanded for incoming signals below 15 db. Excellent for background music applications where the dynamic range should be compressed.

AUTOMATIC MASTER GAIN CONTROL - Simply replace the program amplifier by plugging in the Leveline Amplifier; the AM-5301 Leveline Unit replaces directly an AM-5117 used as a program amplifier or as a monitor amplifier of 6 watts by employing the same strapping used for the AM-5117.

AUTOMATIC LEVEL CONTROL FOR A REMOTE LINE --- The Leveline units permit unattended operation of the remote line.

AUTOMATIC CONTROL OF LEVEL DIFFERENCES BETWEEN 2 OR MORE PROGRAM SOURCES - Controls differences between turntables, projectors, network programs and microphone preamplifier sources.

USE AS A "DUCKER" - The AM-5301 permits automatic "ducking". A program can be automatically lowered the recommended 8 db (one-half loudness) to allow an announcer to override without apparent program interruption. The announcer begins to speak, and the background automatically lowers while allowing full announce level.

USE AS A NORMAL PROGRAM AMPLIFIER - If the Console Panel Accessory Controls are not employed, turning off the integral chassis bias limiting control allows operation as a conventional program amplifier; otherwise, regulating the console accessory bias limiting control to extreme "High" will accomplish the same action.

ELECTRICAL CHARACTERISTICS

GAIN:	53 db with 600 ohm input source
INPUT SOURCE:	125 to 600 ohms balanced or unbalanced
IMPEDANCE:	See chart on page 15 for proper loading resistor
OUTPUT POWER:	+37 dbm when strapped for monitor, +26 dbm strapped for Leveline operation.
OUTPUT NOISE:	Unweighted, equivalent to an input signal of -110 dbm or less over the band 20 - 20,000 cps

LIMITER AMPLIFIER

- FREQUENCY RESPONSE:** $\pm .5$ db 20-20,000 cps
- DISTORTION:** Less than 1% at +36 dbm operating levels including compression. Less than .5% at +26 dbm
- COMPRESSION RATIO:** Adjustable from 1.6:1 to 5:1 over a 30 db range at input with 4:1 being optimum
- ATTACK TIME:** 11 Milliseconds as supplied; resistor change permits lowering in increments down to 100 microseconds.
- RELEASE TIME:** For 63% recovery, .5 seconds in "dual" position; 3 seconds in "average" position.
- TUBE COMPLEMENT:**
- 1 - 12AY7-select (Langevin Model TUS-12AY7)
 - 1 - 6ES8 Variable Gain Input Amplifier (Langevin Model TUS-6ES8)
 - 2 - 6005 5 Star Output Amplifiers (Langevin Model TUS-6005)
- BIAS RECTIFIER:** 2 - Silicon Bias Rectifiers
- POWER REQUIREMENTS:** 6.3 Volts ac or dc at 1.5 amperes; 300 vdc at 90 ma strapped for monitor; 50 ma strapped for Levelline operation

MECHANICAL SPECIFICATIONS

- MOUNTING TRAY:** Langevin Model TRY-5017
- FINISH:** Light gray baked enamel over 18 gauge bonderized (rustproofed) steel
- WEIGHT:** 4 lbs. net, shipping 5 lbs.
- SIZE:** Length 10 $\frac{1}{4}$ in., width 2 $\frac{5}{8}$ in., height 3 in.



METER

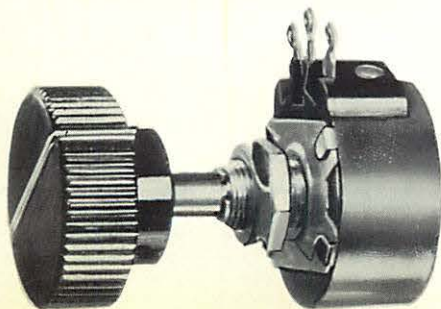

RESISTOR

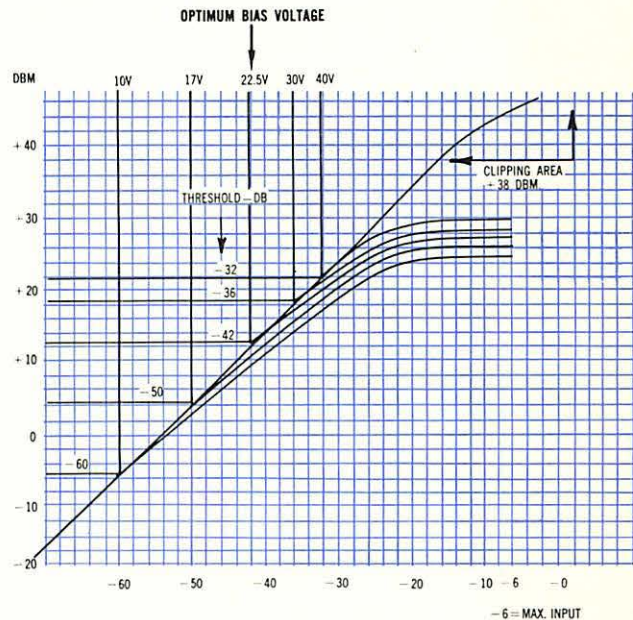

RECOMMENDED ACCESSORIES

- Model MTR-507 Bias Voltmeter
- Model TRY-5017 Mounting Tray
- Model VR-112 100K Extension Bias Control
- Model TK-5301 Tube Kit

ORDERING INFORMATION

- MODEL AM-5301 LEVELINE AMPLIFIER**, complete, with tubes, weight 4 lbs. net, shpg. 5 lbs.
- MODEL AM-5301 LEVELINE AMPLIFIER LESS TUBES**, same as above but less tubes,
- MODEL TK-5301 TUBE KIT** for above, consisting of 1 each (Langevin Model TUS-6ES8), 2 each 6005 5 star (Langevin Model TUS-6005) and 1 each 12AY7, select, (Langevin Model TUS-12AY7). Weight, net $\frac{1}{4}$ lb., shipping $\frac{1}{2}$ lb.
- MODEL MTR-507 BIAS VOLTMETER**, special scale marked for optimum operating point of AM-5301 Leveline Amplifier. Panel size is 1 $\frac{13}{16}$ in. round opening for rear panel mount, 1 $\frac{1}{8}$ in. square overall, depth is 1 $\frac{1}{8}$ in.; reading is 0-70 vdc, weight 3 oz. net, shipping 10 ozs.
- MODEL VR-112 100K** continuously variable moulded composition resistor for panel mount bias limiting control of AM-5301, includes knob but no dial, weight 4 oz. net, shipping $\frac{1}{2}$ lb.
- MODEL TRY-5017 MOUNTING TRAY** for above, with plug socket complete.

RECOMMENDED WIRING AND GROUNDING PRACTICES

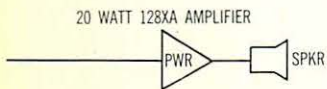
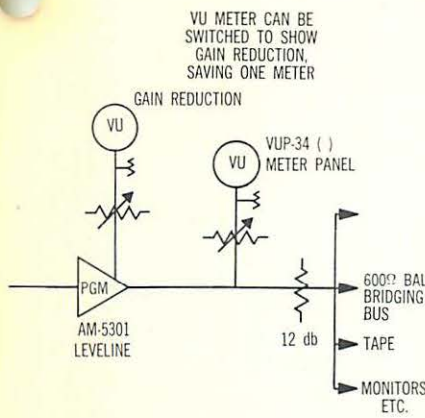

CASE OR CHASSIS GROUNDS — OK TO BUSS

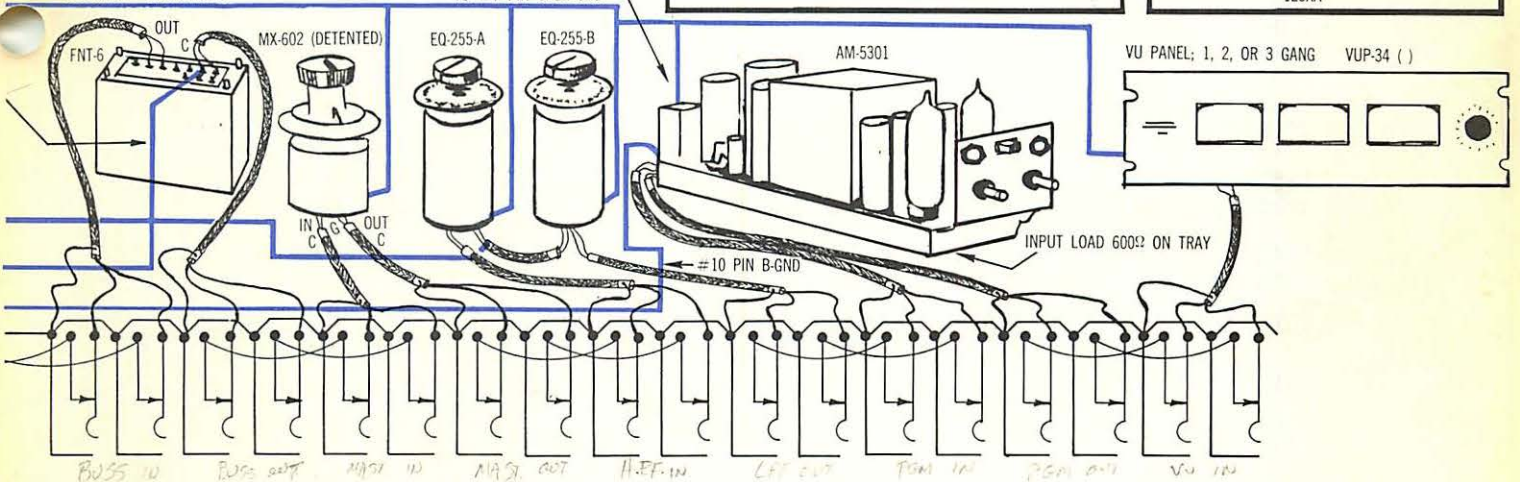

NOTES:

1. GROUND THE SHIELD OF A CABLE AT **ONE** END ONLY!
2. CONNECTION BETWEEN ONE SYSTEM AND ANOTHER **MUST** BE THROUGH TF-602-C LINE TO LINE COILS FOR ISOLATION, OR ONE SYSTEM **MUST** OUTRANK THE OTHER AND SUPPLY THE EARTH GROUND.

3. FOR CONSISTENCY — WHEN CABLES APPEAR BETWEEN TERMINAL BLOCKS OR STRIPS AND JACKS, GROUND THE SHIELD AT THE JACK. IF THE CABLE APPEARS ON A TERMINAL BLOCK OR STRIP BUT NOT AT JACKS GROUND AT THE TERMINAL BLOCK OR STRIP. FOR CABLES BETWEEN PIECES OF EQUIPMENT, FOR EXAMPLE, AMPLIFIERS, HI AND LO PASS FILTERS, ETC., TIE THE SHIELD THROUGH A **SEPARATE** WIRE TO THE MAIN GROUND BAR IN THE CONSOLE OR EQUIPMENT.

4. MAKE CERTAIN THAT SHIELDS NEVER CARRY SIGNAL NOR CURRENT.

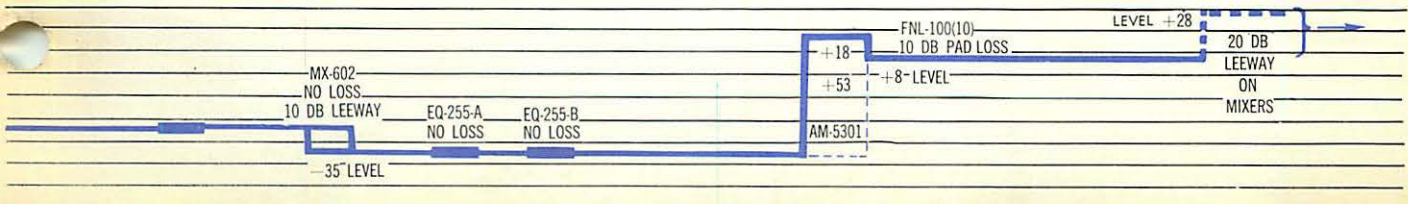

PUSH BUTTON SELECTION FOR STEREO

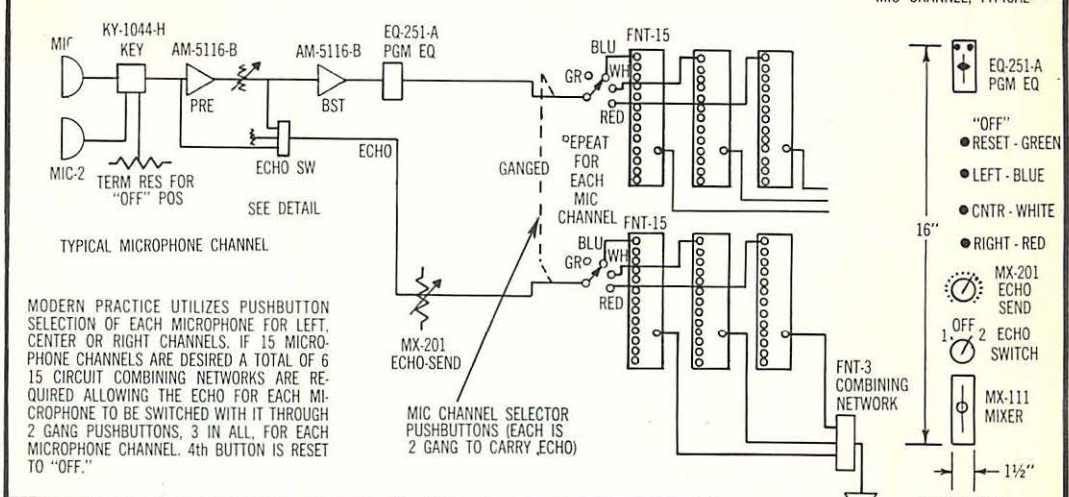

MODERN PRACTICE UTILIZES PUSHBUTTON SELECTION OF EACH MICROPHONE FOR LEFT, CENTER OR RIGHT CHANNELS. IF 15 MICROPHONE CHANNELS ARE DESIRED A TOTAL OF 6 15 CIRCUIT COMBINING NETWORKS ARE REQUIRED ALLOWING THE ECHO FOR EACH MICROPHONE TO BE SWITCHED WITH IT THROUGH 2 GANG PUSHBUTTONS, 3 IN ALL, FOR EACH MICROPHONE CHANNEL. 4th BUTTON IS RESET TO "OFF."

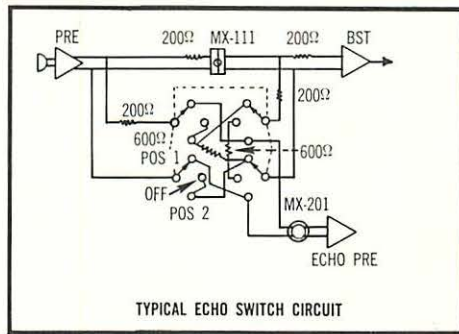



POWER SUPPLIES

HIGH VOLTAGE POWER SUPPLIES

The Langevin Model PS-205-C Power Supplies are silicon rectifier type units providing a maximum of 425 ma at 300 volts for plate power, and two sources of 6.3 volts at 8 amperes each for filament power. Shown also are the PS-5208-A and PS-5206 units which

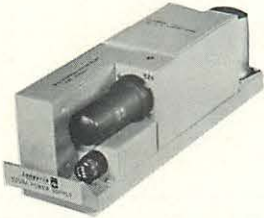
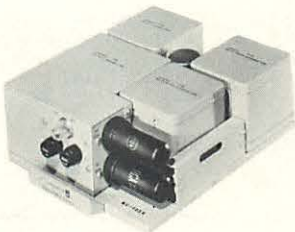
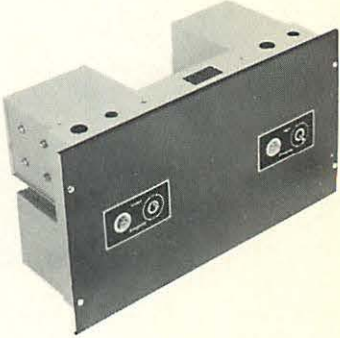
occupy only 3½ inches of rack height. These power supplies have been designed for use with the Standard Langevin plug-in amplifiers and pre-amplifiers or equivalent.

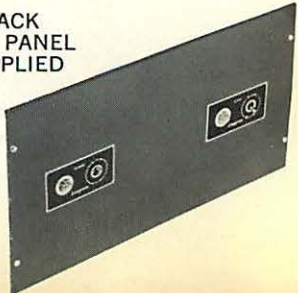
			
MODEL	PS-5208-A	PS-5206	PS-205- C
INPUT:	105 to 125 vac, 50/60 cycles	105 to 125 vac, 50/60 cycles	105 to 125/210 to 250 vac, 50/60 cycles
DC OUTPUT:	300 volts, 90 ma continuous	300 volts, 210 ma continuous. (A 275 volt tap is provided which will furnish up to 70 ma continuous. However, the sum of the simultaneous currents at 300 volts and 275 volts must not exceed 210 ma.)	2 Section Filter: 425 ma max. @ 220 to 300 volts. 3 Section Filter: 150 ma max. @ 180 to 260 volts. Total current drain—425 ma max.
OUTPUT RIPPLE:	Less than 10 millivolts @ full load	Less than 10 millivolts @ 300 volt tap. Less than 2 millivolts @ 275 volt tap	2 Section Filter: Less than 25 millivolts, full load 3 Section Filter: Less than 1 millivolt, full load
AC OUTPUT:	6.3 volts, 3 amperes continuous	6.3 volts, 6.5 amperes continuous	2 transformers, 6.3 volts at 8 amperes each transformer
RECTIFIER OR TUBE COMPLEMENT:	1 type 5Z4	2 type 5Z4	silicon diodes
POWER CONSUMPTION:	100 va @ full load	160 va @ full load	350 va @ full load
SIZE:	Length 10¼ in., width 2⅝ in., height 3 in.	Length 9¾ in., width 7¾ in., height 3¼ in.	Length 18¾ in., width 8¾ in., height 10¼ in.
WEIGHT:	6 lbs., 5 oz.	17 lbs., 6 oz.	52 lbs.
SHIPPING WEIGHT:	6 lbs., 13 oz.	18 lbs.	70 lbs.
FINISH:	Light gray baked enamel over 20 gauge bonderized (rustproofed) steel	Light gray baked enamel over 16 gauge bonderized (rustproofed) steel	Light gray baked enamel over 16 gauge bonderized (rustproofed) steel
MOUNTING:	Plug-in, Langevin Model TRY-5017 Mounting Tray	Plug-in Langevin Model TRY-5019 Mounting Tray	Rack; mat panel supplied
TRAYS:	TRY-5017 	TRY-5019 	RACK MAT PANEL SUPPLIED 

MODEL 1-C AUDIO PEAK CLIPPING AMPLIFIER

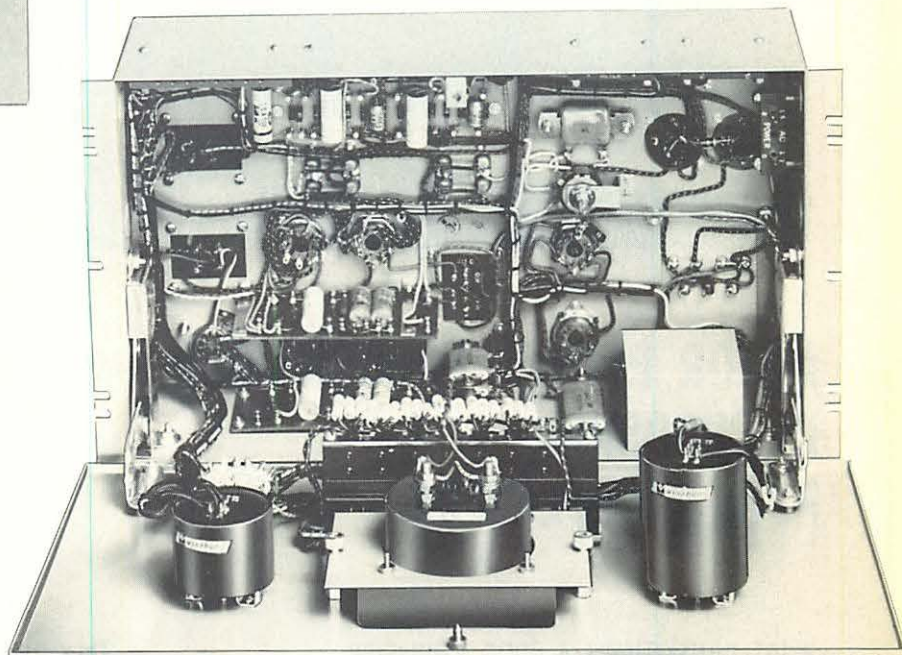
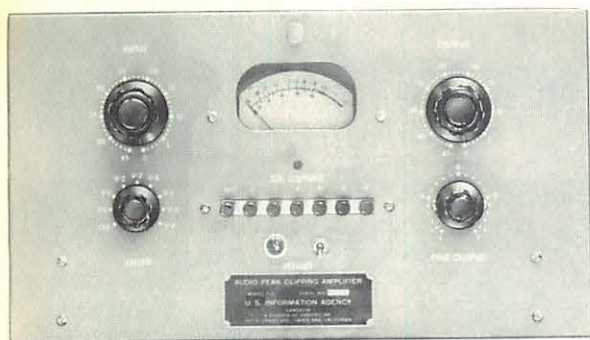

FEATURES

High intelligibility through shaped response curve
As much as 15 db of clipping
Up to 32 times effective power from transmitter
Almost 4 times signal loudness
Compact and Self-Powered

The Model 1-C Audio Peak Clipping Amplifier is used to give a higher average percentage of modulation and to improve the intelligibility of international shortwave radio broadcasting programs. It includes a circuit which effectively prevents over-modulation of the transmitter through a peak clipping action. The frequency response characteristics and clipping action are combined to produce higher intelligibility by increasing the amplitude of consonant sounds relative to vowel sounds.

FOUR FILTERS CONTROL FREQUENCY RESPONSE

Four filters are incorporated to produce the desired curve shape to the frequency response characteristic. An RC network droops the low frequencies 8 db at 50 cps, decreasing distortion due to clipping at these frequencies and improving intelligibility. The second network is m-derived and cuts off sharply above 7 kcps. This restricts the bandwidth of the radiated signal, diminishes interference on adjacent channels and potential higher order harmonics which may arise from the clipping action. The third filter is a pre-emphasis network which increases response from 2 to 7 kcps, with a crest at 4800 cps. The result is a response which is complimentary to the average energy curves for voice and music as published by Fletcher and others. The fourth filter, following the clipping action, assists the second filter in suppressing the balance of any higher order harmonics and transients which might cause interference on adjacent channels.

While it is recognized that this method of increasing effective modulation and intelligibility results in harmonic distortion, its application to international broadcasting is not objectionable when contrasted with distortion developed by transmission paths and average receivers.

SPECIFICATIONS

Gain: 66 ± 2 db at 1000 cps
Input: bridging or matching 600 ohms
Output Impedance: 600 ohms, balanced or unbalanced
Output Power: +24 dbm, at point of clipping, with output attenuator at zero attenuation
Noise: -50 dbm
Distortion: Less than 6% total harmonic distortion with 1 kcps at point of clipping; less than 1.5% 5 db below point of clipping
Frequency Response Characteristic: 8 db down at 50 cps, flat at 1000 cps rising to +10 db at 4800 cps, down 12 db at 9 kcps and down 50 db at 10 kcps
Tube Complement: 5 each 6SJ7, 2 each 6V6 and 1 each OD-3. Unit is furnished with added spare set of tubes
Power Requirements: 105-125 vac at 9a, 40-60 cps; 210-250 vac at 4.5a, 40-60 cps
Mounting: Recessed panel type for rack or equipment cabinet; front panel hinged to chassis; 10½" rack multiple
Weight: 60 lbs. shipping (wooden crate)
Finish: Light gray

ORDERING INFORMATION

Model 1-C Audio Peak Clipping Amplifier, complete with tubes, additional spare set of tubes and full instructions for set-up and operation.

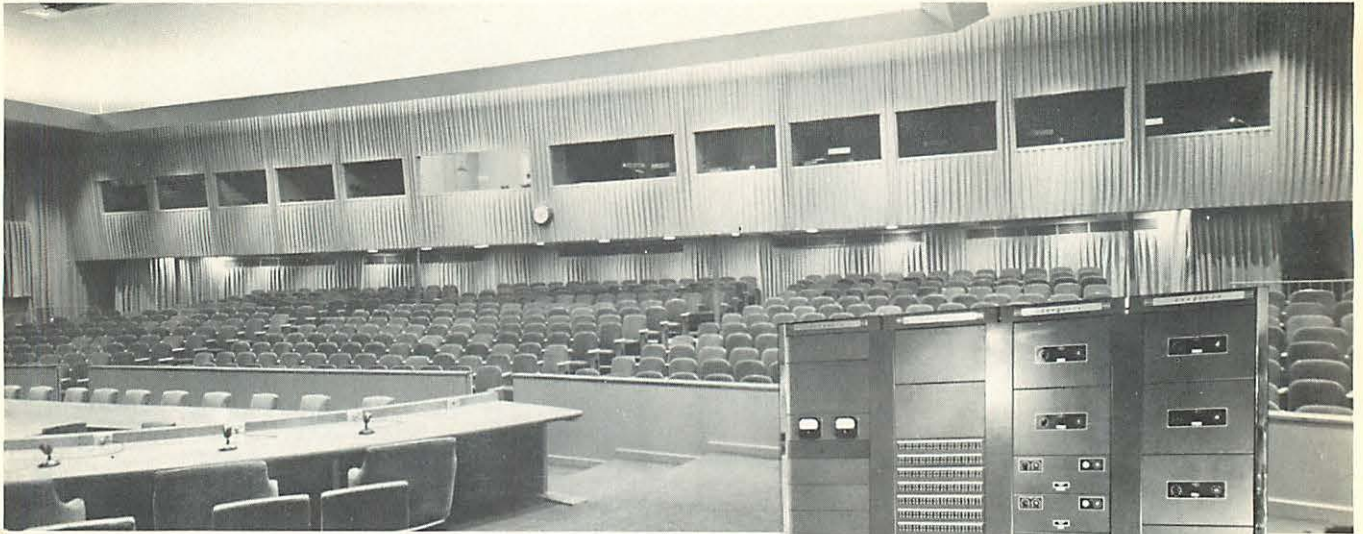

MAJOR POINTS TO CONSIDER IN CHOOSING POWER AMPLIFIERS

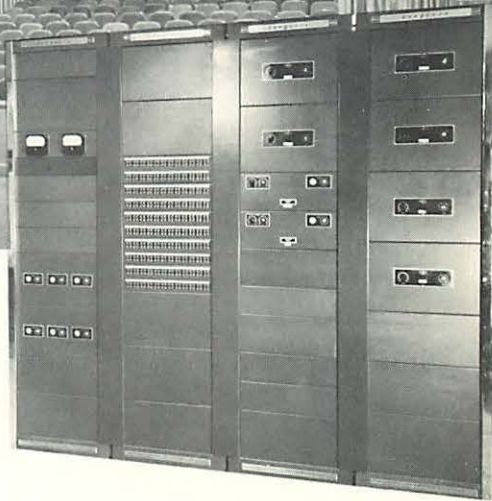

SECURITY COUNCIL CHAMBER UNITED NATIONS

WHAT CONSTITUTES A GOOD AMPLIFIER

In the early development of any art the establishment of standards serves to deter progress. The design, development and manufacture of amplifiers is no exception, for nowhere do specifications attain meaning without confusing qualifications. This is especially true where the consumer compares the data sheets of one amplifier manufacturer with another and attempts a decision on the basis of range response, power output, distortion and price.

For these considerations do not deliver a clue to quality, reliability and value. Such factors are the most difficult for there are no measuring instruments calibrated in these terms.

But the discriminating user knows that somewhere good, reliable amplifiers at a fair price are produced. Langevin, for thirty five years, has recognized this demand — and takes this opportunity to tell you something about its product.

LANGEVIN AMPLIFIERS ARE RELIABLE

They Run Cool

The enemy of reliability is heat. Langevin power amplifiers are large, well ventilated and run cool on continuous, year in, year out duty cycle. Transformers are two to four times the size of those used in other amplifiers of comparable power, and provide high efficiency and generous heat dissipation. Wire sizes are 2 or 3 gauges larger than usual; insulation is rated at 180 degrees centigrade instead of the ordinary 120 degrees.

They Have Long Life

The best components available are used in Langevin amplifiers: Allen Bradley potentiometers, Sprague condensers, Ward Leonard and Allen Bradley resistors in important circuits. Filter capacitors are always operated far below their usual rating.

LANGEVIN AMPLIFIERS ARE VERSATILE

In the succeeding pages you find proof of versatility. This means that Langevin amplifiers give good value, for the various accessories, modification groups and multiple input panels available guarantee the complete fulfillment of the function you require. Whether the amplifier is for monitoring, wired music installations, high quality public address or musicasting, you find full accommodation to your need without paying for excess circuits that you cannot use.

LANGEVIN AMPLIFIERS HAVE QUALITY

You take wide-range, distortion-free response at low or high powers for granted with these amplifiers, for the ratings are ultra-conservative. Langevin amplifiers perform not only on the test bench with resistive loads, but under dynamic operating conditions with reactive speaker loads, high or low capacity, with or without the load connected. Phase shift is kept low and they will not oscillate under adverse conditions.

These amplifiers fulfill your expectations.

LANGEVIN MUSICAST 8 WATT AUDIO AMPLIFIERS

**LOW Z MICROPHONE AMPLIFIER
DISC PLAYBACK AMPLIFIER
HIGH Z INPUT AMPLIFIER
MONITOR BRIDGING AMPLIFIER**

- SELF-CONTAINED POWER SUPPLY
- 4 INTERCHANGEABLE INPUT PANELS
- POWER OUTPUT OF 8 WATTS
- CONTINUOUS DUTY CYCLE
- COMPACT
- RUGGED CONSTRUCTION OF 16 GAUGE COLD ROLLED STEEL CHASSIS
- PLUG-IN TYPE CONNECTORS

Specifically designed for the highest quality sound systems the Langevin AM-138 Series Amplifiers provide low noise, low distortion performance over a wide frequency range. Special design features contained in these amplifiers ease the task of the audio engineer in creating newer and superior sound systems.

All the amplifiers in the AM-138 Series have self-contained power supply. They feature 4 interchangeable input panels. Taps on the output transformer for the entire AM-138 Series permit easy matching at 4, 8, 16, 150, and 600 ohms.

Small and compact, these amplifiers can be mounted in consoles and cabinets or directly in a monitor speaker housing. Where several AM-138 Amplifiers are required, as in a rack installation, as many as four may be mounted on a standard Langevin MF-10-B Mounting Frame.

The overall construction of the AM-138 Series Amplifiers adheres to the usual Langevin standard of quality.

The Langevin AM-138 Series Audio Amplifiers are indispensable where ever fine sound reproduction is specified.

ACCESSORIES PROVIDED

Along with the AM-138 Series Amplifiers are provided the following accessories:

- 1 - Miniature type Hubbel plug receptacle for supplying the ac to the unit.
- 1 - 4 pin Jones Connector and cover for the output stage.
- 1 - 10 pin Jones Connector and cover for the input stage.

These accessories are automatically provided with the Model AM-138 Series at no additional cost.

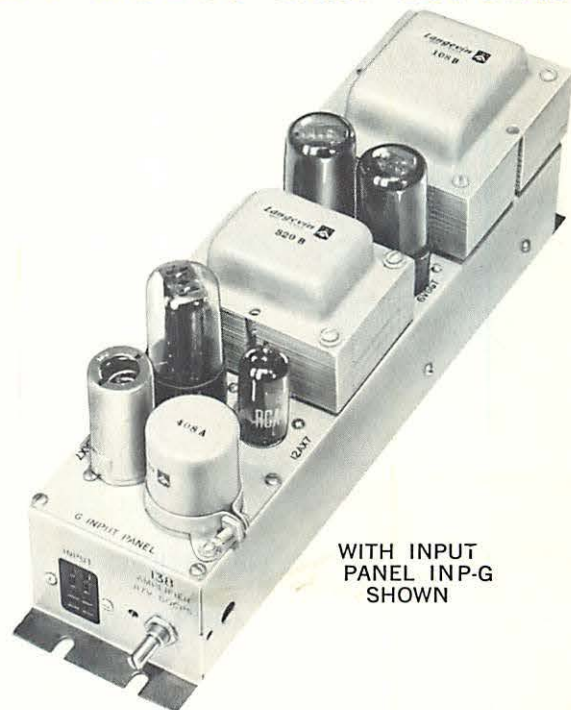

WITH INPUT
PANEL INP-G
SHOWN

PERFORMANCE CHARACTERISTICS

HARMONIC DISTORTION: All models: less than 2.0%, 50 to 15,000 cps at +39 dbm.

AM-138S-G LOW Z MICROPHONE AMPLIFIER: Includes pre-amplifier input for low impedance microphones.

SOURCE IMPEDANCE: 30, 150, 250, 600 ohms.

GAIN: 104db, 600 ohms input, 600 ohms output at 1 kc.

OUTPUT NOISE: -63 db below full output.

RESPONSE: ± 1.5 db 30 to 15,000 cps.

AM-138S-K DISC PLAYBACK AMPLIFIER: Includes pre-amplifier equalized for GE or Pickering type pick-ups.

SOURCE IMPEDANCE: 6800 ohms.

GAIN: 75.3 db bridging 600 ohms at 1 kc.

OUTPUT NOISE: -52 db below full output.

AM-138S-L AMPLIFIER WITH HIGH Z INPUT: Includes pre-amplifier input for high impedance microphones or crystal pick-up.

SOURCE IMPEDANCE: 1 megohm.

GAIN: 77 db bridging 600 ohms at 1 kc.

OUTPUT NOISE: -63 db below full output.

RESPONSE: ± 1.5 db 30 to 15,000 cps.

AM-138S-M MONITOR BRIDGING AMPLIFIER: Includes an input panel designed for bridging or cueing.

SOURCE IMPEDANCE: 150, 600, 5,000 and 20,000 ohms.

GAIN: 58 db, 600 ohm input, 600 ohm output at 1 kc.

OUTPUT NOISE: -76 db below full output.

RESPONSE: ± 1.0 db 30 to 15,000 cps.

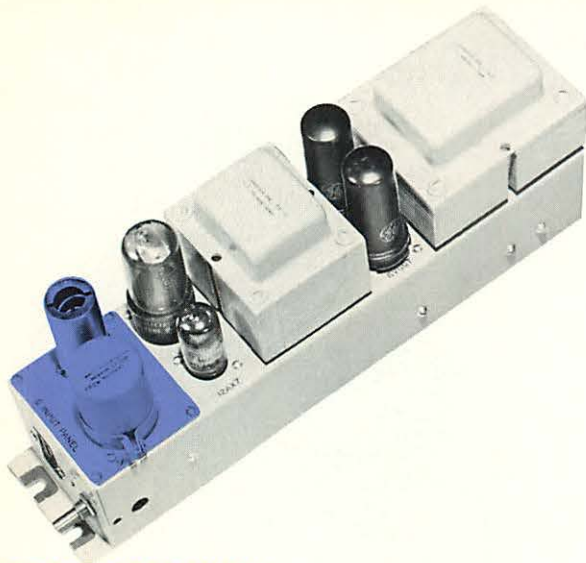

ORDERING INFORMATION

MODEL AM-138S-G LOW Z MICROPHONE AMPLIFIER, complete with tubes,

MODEL AM-138S-G LOW Z MICROPHONE AMPLIFIER LESS TUBES, same as model AM-138S-G Low Z Microphone Amplifier but less tubes

MODEL AM-138S-K DISC PLAYBACK AMPLIFIER, complete with tubes,

MODEL AM-138S-K DISC PLAYBACK AMPLIFIER, LESS TUBES, same as model AM-138S-K Disc Playback Amplifier, but less tubes,

MODEL AM-138S-L AMPLIFIER WITH HIGH Z INPUT, complete with tubes,

MODEL AM-138S-L AMPLIFIER WITH HIGH Z INPUT, LESS TUBES, same as model AM-138S-L Amplifier with high Z input, but less tubes,

MODEL TK-138S-L TUBE KIT, for AM-138S-G, K and L, consists of 2 each 6V6GT (Langevin TU-6V6GT), 2 each 12AX7 (Langevin TU-12AX7), and 1 each 5Y3GT (Langevin TU-5Y3GT). Weight, Net, ¼ lb.; shipping ½ lb.

MODEL AM-138S-M MONITOR BRIDGING AMPLIFIER, complete with tubes,

MODEL AM-138S-M MONITOR BRIDGING AMPLIFIER, LESS TUBES, same as model AM-138S-M Monitor Bridging Amplifier, but less tubes,

MODEL TK-138S-M TUBE KIT for above, consists of 2 each 6V6GT (Langevin TU-6V6GT), 1 each 12AX7 (Langevin TU-12AX7) and 1 each 5Y3GT (Langevin TU-5Y3GT). Weight, Net, ¼ lb., shipping ½ lb.

MODEL AM-138S BASIC AMPLIFIER, less tubes and input panel; requires appropriate input panel INP-G, INP-K, INP-L, or INP-M as listed below and appropriate tube kit.

MODEL TU-12AX7 TUBE KIT, consists of one type 12AX7 Tube (Langevin TU-12AX7) for Models INP-G, INP-K and INP-L input panels above. Weight, Net, 3 oz.; shipping, 6 oz.

MODEL MF-10-B MOUNTING FRAME, for rack mounting up to 4 model AM-138 Series Amplifiers. Weight, Net, 5½ lbs.; shipping, 9 lbs.

MECHANICAL CHARACTERISTICS

SIZE: Length, 12¾ in., width, 3¼ in., height, 5¼ in.

WEIGHT: 13½ lbs. net, 15 lbs. shipping.

FINISH: Light grey baked enamel over 16 gauge bonderized (rustproofed) steel.

MODEL INP-G LOW Z MICROPHONE INPUT PANEL, for model AM-138S basic amplifier, less 12AX7 tube, weight, net ¼ lb., shipping, ½ lb.

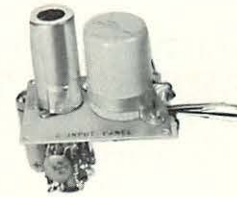

MODEL INP-K DISC PLAYBACK INPUT PANEL, has necessary gain and equalization for magnetic pick-up, for model AM-138S basic amplifier, less 12AX7 tube. Weight, Net, ¼ lb.; shpg., ½ lb.

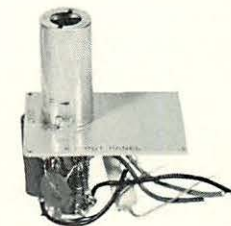

MODEL INP-L HIGH Z INPUT PANEL, has necessary gain for high Z microphones or ceramic and crystal pick-up, for model AM-138S basic amplifier, less 12AX7 tube. Weight, ¼ lb.; shpg., ½ lb.



MODEL INP-M MONITOR BRIDGING INPUT PANEL, includes transformer, no tube required, for model AM-138S basic amplifier.



LANGEVIN MUSICAST 20 WATT AUDIO AMPLIFIER

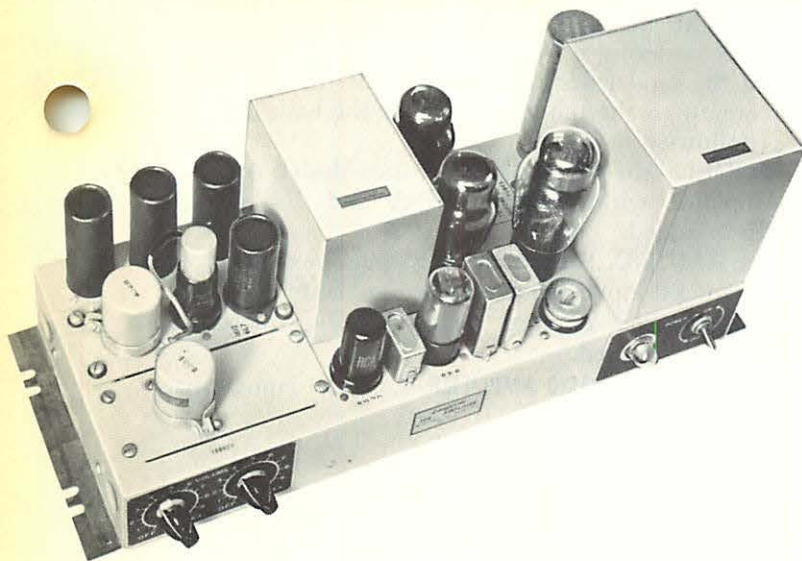

MODEL AM-128X SERIES SOUND SYSTEMS EQUIPMENT

The Langevin Model AM-128X Series Amplifiers are 20 watt units designed for high quality sound systems. Quiet, low distortion performance over a wide frequency range at rated power output highlights the electrical characteristics which make these amplifiers desirable where fine sound reinforcement or reproduction is required.

DESIGN FEATURES

Design features of the Model AM-128X Series make these amplifiers adaptable to the varied requirements of sound installations. These features include seven interchangeable input panels as shown on page 24-5.

Taps on the output transformer permit matching the amplifier output to any load impedance from 1 to 1,000 ohms.

The low output noise characteristic and low internal output impedance of these units make them ideal for use as the power unit to drive a low impedance bus across which many power amplifiers can be bridged in large sound installations.

Good regulation of output is provided in the Langevin AM-128X Series by very low internal output impedance; the change in output level from a condition of "no load" to a condition of "full load" is only 1 db. As measured with a complex wave form such as speech or music, the internal output impedance averages about 1/6 of the nominal load impedance.

IDEAL FOR MULTI-CHANNEL STEREO

It has been shown in the literature that a level difference of only 3 db between right and left sound sources is enough to completely displace the apparent source from one side of the sound field to the other. In these amplifiers, whether used in 2 channel or 3 channel array, Langevin ganged and detented attenuators can be used as volume controls to give absolute tracking at all level settings.

On those input panels providing bridging inputs and lower, standard ganged Langevin step type attenuators are to be found in this catalogue for any impedance desired, either for bridging or 600 ohms and lower. Trimming of the amplifiers for accurate balance can be accomplished by inserting a Langevin Model VR-111 continuously variable calibration control in series with 1 leg. See attenuator section.

ELECTRICAL SPECIFICATIONS

Specifications vary on this series of amplifiers according to the input panel employed. Listed in this section are those specifications common to all combinations of input panels and the AM-128X Basic unit:

LOAD IMPEDANCE: Nominal 2, 8, 16, 32, 150, or 600 ohms.

OUTPUT POWER: Output level 43 vu (20 watts). Total rms harmonic distortion 50 to 15,000 cycles, less than 2%.

TUBE COMPLEMENT: 1 type 6SJ7, 1 type 6V6GT, 2 type 6L6GA and 1 type 5U4G.

ADDITIONAL SPECIFICATIONS FOR MODEL AM-128X AMPLIFIER WITH PRE-AMPLIFIER INPUT FOR LOW IMPEDANCE MICROPHONES AND PHONO PICK-UPS

MODEL AM-128X-B

SOURCE IMPEDANCE: 30 or 250 ohms.

MAXIMUM GAIN: Approximately 103 db.

OUTPUT NOISE: Unweighted, 53 db below full output power (+43 dbm).

ADDITIONAL SPECIFICATIONS FOR MODEL AM-128X AMPLIFIER WITH PRE-AMPLIFIER INPUT FOR HIGH IMPEDANCE

MODEL AM-128X-C

SOURCE IMPEDANCE: 1 megohm.

MAXIMUM GAIN: 84 db.

OUTPUT NOISE: Unweighted, 60 db below full output power (+43 dbm).

ONE OR TWO INPUT CHANNELS CAN BE USED

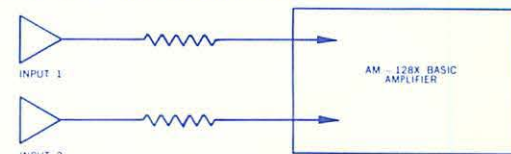

The basic AM-128X Amplifier can be supplied with any one or any combination of two of these input panels already installed. Assemblies are available for adding pre-amplifier input panels to a single channel amplifier already in service.

INPUT PANELS

DESCRIPTION

- INP-A** Line level input panel with transformer for matching 600 ohms; 35,000 ohms for bridging.
- INP-B** Pre-amplifier input panel for source impedance of 250 ohms.
- INP-E** Pre-amplifier input panel for high impedance inputs.
- INP-H** Pre-amplifier, equalized for GE or Pickering pick-ups.
- INP-J** Input panel for high impedance radio tuners or equivalent.
- INP-R** Input panel for Monitor (broadcast use) for source impedance of 30/150/250/600 ohms.
- INP-Q** Input panel similar to INP-R, except supplied with 100K volume control, and the input circuit is arranged for minimum "cross-talk" effect.

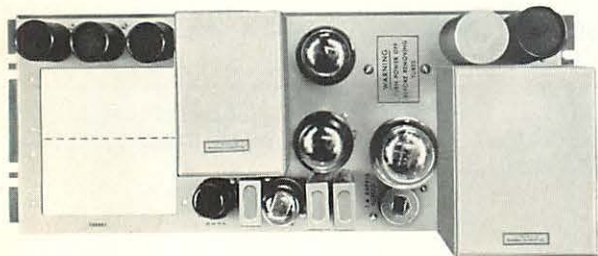

MOUNTING DETAILS

The Model AM-128X Amplifier can be either rack or cabinet mounted. When rack mounted, a modification is required. (Modification Group Model MG-21-A). This modification includes brackets to remount the power switch, pilot light and volume controls, and a mat panel. The amplifier will fit the standard 19 inch equipment rack.

MECHANICAL SPECIFICATIONS

SIZE: Length, 18 3/4 in., width, 7 3/4 in., height, 7 3/4 in. (requires 7 in. of panel space when rack mounted).

FINISH: Light grey baked enamel on zinc-plated, 16 gauge steel.

CABINET MOUNTING

A Langevin Model WC-1202 cabinet is available for wall, ceiling or shelf mounting this amplifier. It is constructed of steel, finished in baked dark grey enamel and is equipped with a removable cover held in position by two knurled thumb screws.

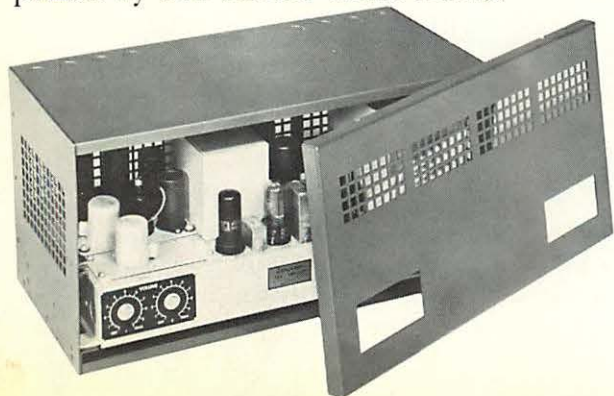

ORDERING INFORMATION FOR MODEL AM-128X SERIES

When ordering a Model AM-128X Series Amplifier, add the model designation letters of the input panels required to the model number of the basic amplifier, as follows:

MODEL AM-128X-AB = Basic Model AM-128X Amplifier with Models INP-A and INP-B Input Panels added.

The AM-128X Series Amplifiers may be ordered with the desired input panels installed at the factory, \$2.50 per panel, net, or input panels may be ordered separately if desired.

MODEL AM-128X BASIC AMPLIFIER, Less input panels

Weight, Net, 26 lbs.; Shpg., 30 lbs.

MODEL INP-A LINE LEVEL INPUT PANEL

600 ohms input, 35,000 ohms bridging; includes 1/4 megohm volume control on secondary of transformer. Gain with AM-128X Basic is 63 db matching 600 ohms, 45 bridging 600 ohms; noise -78 db below full output (+43 dbm) unweighted. Input level is -20 dbm. Weight, Net, 1/4 lb.; shipping, 1/2 lb.

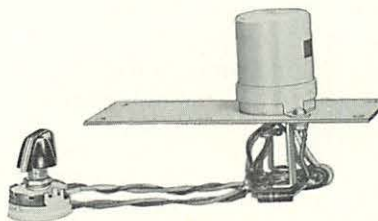

MODEL INP-B LOW Z HIGH GAIN INPUT PANEL Microphone preamplifier with 250 ohm balanced or unbalanced input. When installed on AM-128X amplifier, maximum gain of system is approximately 115 db. Gain is adjustable by screwdriver control on INP-B. Noise, unweighted, of system is better than 60 db below full output of AM-128X. Supplied with main panel 250 Kohm audio taper gain control and 12AX7 or ECC-83 tube. Weight, Net, 1/4 lb, 1/2 lb shipping.

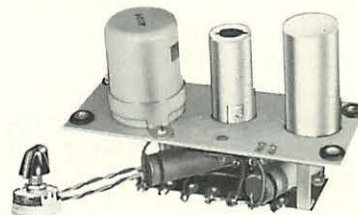

MODEL INP-E HIGH Z HIGH GAIN INPUT PANEL For high impedance microphones; identical to INP-B Input Panel except for unbalanced input Z of one megohm.

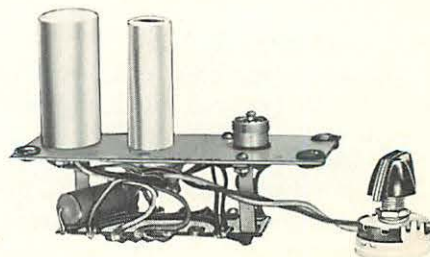

LANGEVIN MUSICAST 20 WATT AUDIO AMPLIFIER

MODEL INP-H DISC PLAYBACK INPUT PANEL, accepts any modern low-level magnetic playback cartridge. Gain is adjustable by screwdriver control. Equalized to RIAA specification for 33 1/3 or 45 rpm disc recordings. Noise is better than 55 db below level caused by 5 mv signal at 1 kcps. Supplied with main panel 250 Kohm audio taper gain control and 12AX7 or ECC-83 tube. Weight, Net, 1/4 lb, 1/2 lb shipping.

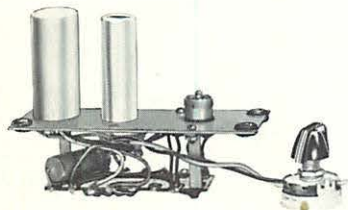

MODEL INP-J HIGH Z INPUT PANEL, for high impedance radio tuners or equivalent. Includes variable 1 megohm maximum level chassis control and additional 1 megohm volume control for panel mount. Gain is 76 db with AM-128X Basic. Noise is -60 db below full output (+43 dbm). Input signal 1-6 volts. Weight, Net, 1/4 lb.; shpg., 1/2 lb.

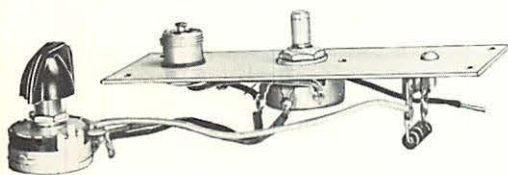

MODEL INP-R MONITOR INPUT PANEL, for input source of 30-150-250-600 ohms; for monitor, broadcast and recording use. External variable low Z attenuator (30-150-250 or 600 ohms) required to control level. Gain is 62 db with AM-128X Basic. Noise is -78 db below full output (+43 dbm). Input signal -20 dbm. Weight, Net, 1/4 lb.; shipping, 1/2 lb.

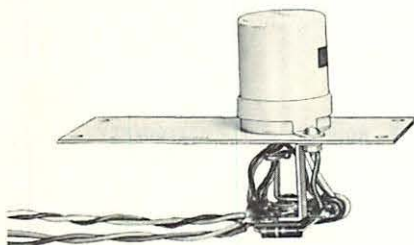

MODEL INP-Q MONITOR INPUT PANEL, same as Model INP-R except equipped with 100K volume control and input is arranged for minimum "crosstalk" effect. Gain is 62 db with AM-128X Basic. Noise is -75 db below full output, (+43 dbm). Input signal -20 dbm. Weight, Net, 1/4 lb.; shipping, 1/2 lb.

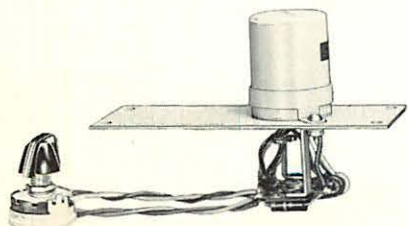

RECOMMENDED ACCESSORIES

MODEL MP-1-A BLANK PLATE

Covers one pre-amplifier space when only one input panel is employed. Includes 4 mounting screws. Weight, Net, 3 oz.; shpg., 5 oz.



MODEL PL-1A PILOT LIGHT ASSEMBLY.

MODEL MG-21-A MODIFICATION GROUP FOR RACK MOUNTING AM-128X AMPLIFIER. Includes mat panel and brackets to remount power switch, pilot light and volume controls. Weight, Net, 3 1/2 lbs.; shpg., 4 1/2 lbs.

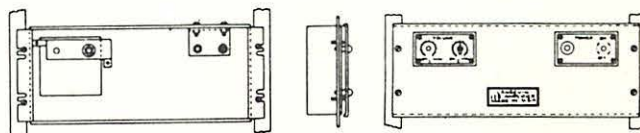

MODEL WC-1202 WALL CABINET for mounting AM-128X Amplifiers on wall, ceiling or shelf, complete with brackets and hardware. Weight, Net, 18 lbs.; shipping, 25 lbs.

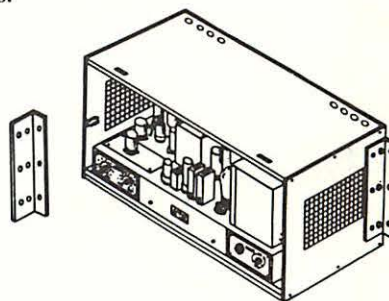

MODEL VR-113 VARIABLE CARBON 4K RESISTOR, special, Allen Bradley, used as volume control. Weight, Net, 2 oz.; shipping 1/4 lb.



LANGEVIN 50 WATT AUDIO AMPLIFIER THE 101-3101 SERIES LINE

The Langevin Model AM-101-D Amplifier meets the need for a "year-in, year-out" dependable 50 watt power amplifier for use as the basic unit in high quality sound systems. This amplifier has proved its dependability in many large installations, such as race tracks, stadia and open air pageants, as well as indoor installations where **DEPENDABLE AUDIO POWER** is required.

The AM-101-D bridges 1 to 25,000 ohms, and matches 600 ohms. An additional stage of amplification for microphones and phono pick-ups can be added to the Model AM-101-D Amplifier. Two different modification groups are available to the user . . . one to adapt to low impedance microphones or phono pick-ups, the other to adapt it to high impedance microphones and ceramic or crystal phono cartridge inputs. Each modification group consists of a pre-amplifier, volume control, and all necessary brackets.

MOUNTING DETAILS

The Model AM-101-D amplifier can be either shelf or wall mounted using a Model WC-1201 cabinet, or it can be mounted in a standard 19" equipment rack.

CABINET MOUNTING

Model WC-1201 wall or shelf mounting cabinet is available for mounting the Model AM-101-D amplifier. This cabinet is constructed of 16 gauge steel, is bonderized, and finished in baked-on grey enamel.



MODEL AM-3101-B Low Z High Gain Amplifier, and MODEL AM-3101-E High Z High Gain Amplifiers, same in appearance except that Amphenol coax input connector takes place of 402-B input coil.

Knockouts are provided for wiring conduits and proper ventilation is assured by grill work on three sides. The cabinet is equipped with a detachable front cover secured by two knurled thumb screws. Brackets are supplied for mounting the cabinet to wall, ceiling or shelf surfaces.

RACK MOUNTING

When it is desired to mount the Model AM-101-D Amplifier in a standard 19" equipment rack, Modification Group Model MG-7-A is required. This modification provides a specially drilled mat panel, escutcheon plate and brackets for re-mounting the amplifier volume control and power switch to make them accessible from the front of the equipment rack.

MODEL	SOURCE IMPEDANCE	MAXIMUM GAIN	OUTPUT NOISE AND DISTORTION	FREQUENCY CHARACTERISTIC
AM-101-D	Match 600 ohms; bridge 1 to 25,000 ohms.	60 db matching 600 ohms; 45 db bridging connection.	Unweighted, -80 db below full output level (+47 dbm) (-33 dbm). Less than 3% total rms distortion from 100 to 8000 cps at 50 watts.	Within ±2 db from 30 to 15,000 cycles.
AM-3101-B	30 or 250 ohms.	Approximately 104 db.	57 db below full output (+47 dbm), (-10 dbm). Less than 3% total rms distortion from 100 to 8000 cps at 50 watts.	±2 db from 50 to 15,000 cycles.
AM-3101-E	1 megohm.	75 db.	-57 db below full output (+47 dbm), (-10 dbm). Less than 3% total rms distortion from 100 to 8000 cps at 50 watts.	±1.5 db from 50 to 15,000 cycles.

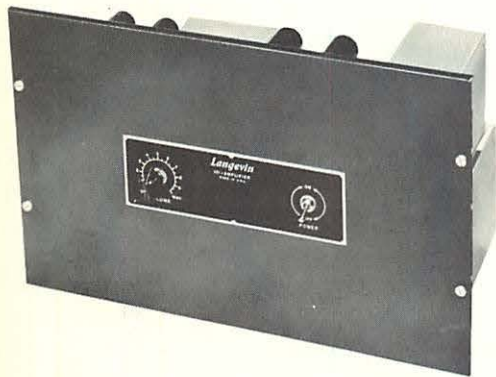
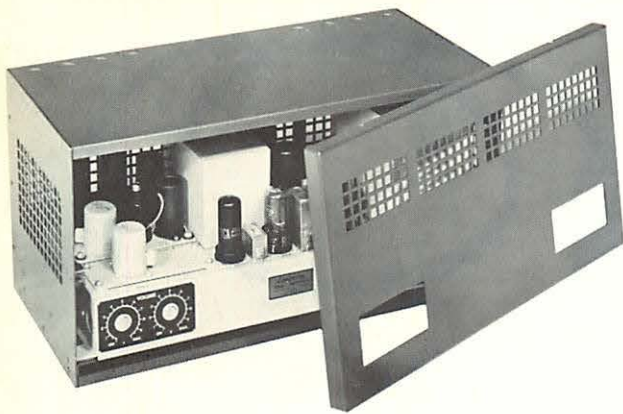

MECHANICAL CHARACTERISTICS

- LENGTH:** 18 13/16" (fits standard 19" equipment rack).
- WIDTH:** 10 1/4" (occupies 12 1/4" of standard rack space).
- HEIGHT:** 8 3/4"
- WEIGHT:** Approximately 45 lbs. net; shpg., 64 lbs.
- FINISH:** Light grey, baked-on enamel over 16 gauge bonderized (rustproofed) steel.

ACCESSORIES

MODEL WC-1201 WALL CABINET, complete with brackets and hardware, used for mounting AM-101-D, AM-3101-B or AM-3101-E to wall, ceiling or shelf. Weight, net, 25 lbs.; shpg., 27 lbs.

MODEL MG-7-A MODIFICATION GROUP, complete with mat panel MP-36-A modified to include escutcheon plate and switch of AM-101-D, AM-3101-B and AM-3101-E. Weight, net, 4 lbs.; shpg., 5 lbs.

MODEL MG-22-A MODIFICATION GROUP, includes Model INP-B Low Z High Gain Input Panel, for converting AM-101-D Bridging Amplifier to low impedance microphone input (converts to AM-3101-B). Comes with bracket, resistors, condensers, wire and instructions for relocating filter condenser and removing bridging input transformer from AM-101-D. Has rectangular remount can but less 1612 tube. Weight, net, 1/2 lb.; shpg., 3/4 lb.

MODEL MG-23-A MODIFICATION GROUP, includes model INP-E High Z High Gain Input Panel for converting AM-101-D Bridging Amplifier to high impedance microphone, ceramic or crystal phono cartridge input (converts to AM-3101-E). Comes with bracket, resistors, condensers, wire and instructions for relocating filter condenser and removing bridging input transformer from AM-101-D. Has rectangular remount can. Weight, net, 1/2 lb., shipping, 3/4 lb.

ORDERING INFORMATION

MODEL AM-101-D BRIDGING AMPLIFIER, complete with tubes.

MODEL AM-101-D BRIDGING AMPLIFIER, LESS TUBES,

MODEL AM-3101-B LOW Z HIGH GAIN AMPLIFIER, complete with tubes,
MODEL AM-3101-B LOW Z HIGH GAIN AMPLIFIER LESS TUBES

MODEL AM-3101-E HIGH Z HIGH GAIN AMPLIFIER, complete with tubes,
MODEL AM-3101-E HIGH Z HIGH GAIN AMPLIFIER WITHOUT TUBES,



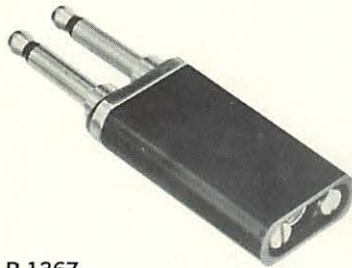

P-1367

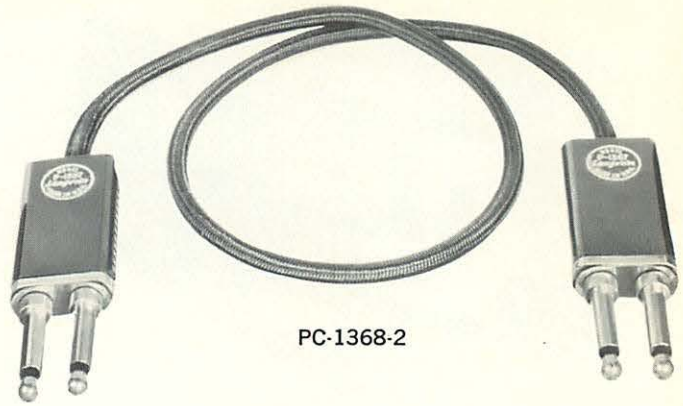

PC-1368-2

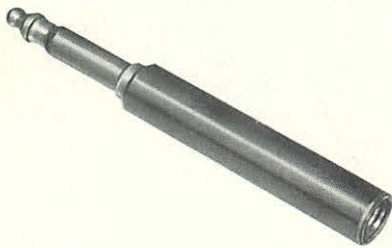

P-607

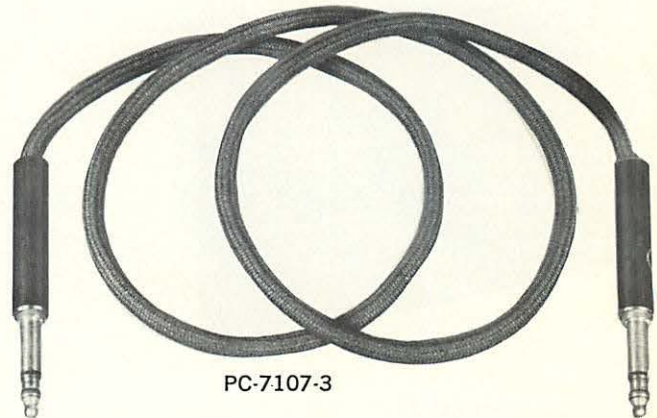

PC-7107-3

GENERAL

Two types of plugs are used in transmission work. These are the single plug, using tip and ring to carry signal with sleeve ground, and the double plug in which the two tips carry signal and both sleeves are ground.

The standard plug for patching sound circuits in motion picture and broadcast studios has for many years been the double type. The chief advantage of this plug has been its reliability and the ability in balanced circuits to turn the plug over to reverse the phase of the program material. The availability of the two plug screws on the rear of the plug allows accessibility to the circuit under operating conditions with bare wire ends, test prods, or the tips of another plug.

The disadvantages of the double plug circuit are the increased space required, and the cost.

In present day transmission circuits the phasing of all elements is carefully checked while initial cabling of the components is engaged in, an absolute necessity in multi-channel stereo circuits. This means that part of the advantage of the double plug circuitry is lost, for the ability to change phase relationships is neither required, nor, in most cases, is it desirable. In fact the possibility of turning over a plug by accident makes the dual arrangement less satisfactory than the tip ring and sleeve single plug system.

Both types of plugs are offered here, as both operate in the Langevin JS-7160 and JS-7180 series Jack Strips. Custom has given the double plug circuitry

the widest usage, and it is for this reason that jack strips for double plugs are featured, although jacks for single plugs may be installed in them by ordering the jack strips and appropriate jacks separately, or by ordering the complete JS-7191 or JS-7192 jack strip and jack assemblies for tip and ring and sleeve plugs only.

MODEL P-1367 DOUBLE PLUG

The Model P-1367 unit is a highly developed twin plug employing both tips to carry the signal. The shield ground of the circuit is connected to both sleeves. The metal conducting parts are formed of brass for easy cleaning by buffing with a plug polisher, or other means. The tip and sleeve are insulated by a bakelite washer, rather than hard rubber which softens under the heat of polishing. Thus, critical alignment is consistently maintained.

The shell is molded of bakelite and polished to maintain a permanently sharp, clean appearance. The thumb side of the shell is notched to mark polarity. The sleeve and tip mounting assembly is terminated in a spring which makes both tip and sleeve assemblies self aligning upon insertion into the jack strip. This eliminates sticking, and insures positive, smooth insertion under all conditions. Ample room is allowed in the body of the plug for making connections. Especially important in Langevin plugs is the shape

of the tip. This shape prevents shorting of the jack contacts to ground; ordinarily causing noise and clicks. Equivalent in function to the WE 218-A.

Precise attention to detail in design and manufacture make Langevin Double Plugs the peer among all plugs in the field.

Similar in construction to the P-1367 Double Plug, the Model P-607 Tip Ring and Sleeve Single Plug carries the signal on the tip and ring with ground on the sleeve. All parts are of the same fine quality found in the double plug, including the formation of the tip to avoid shorting jack elements with consequent noise.

ORDERING INFORMATION

Model P-1367 Double Plug.

Model P-607 Tip Ring and Sleeve Single Plug.

PATCH CORDS WITH DOUBLE PLUGS

Utilizing the Model P-1367 Double Plugs, these Patch Cords are available in convenient lengths and colors. Conductors are shielded with special, highly flexible tinsel and covered with long wearing mercerized cotton braid. This allows complicated circuit patching without tangles and kinks between patch cord assemblies. Shield is attached to one plug assembly only to avoid ground loops and cannot be used as a conductor. The shortest cord length should always be used between jack positions to avoid confusion and tangles from excess cord.

ORDERING INFORMATION

PATCH CORDS WITH DOUBLE PLUGS

MODEL*	LENGTH, FEET
PC-1368-1	1
PC-1368-2	2
PC-1368-3	3
PC-1368-4	4
PC-1368-5	5
PC-1368-6	6

PATCH CORDS WITH TIP RING AND SLEEVE SINGLE PLUGS

Uses the Model P-607 Tip Ring and Sleeve Single Plugs with same cords as employed on Langevin Patch Cords with Double Plugs.

MODEL*	LENGTH, FEET
PC-7107-1	1
PC-7107-2	2
PC-7107-3	3
PC-7107-4	4
PC-7107-5	5
PC-7107-6	6

PATCH CORDS ONLY

For P-1367	For P-607	LENGTH, FEET
PC-1369-1	PC-710-1	1
PC-1369-2	PC-710-2	2
PC-1369-3	PC-710-3	3
PC-1369-4	PC-710-4	4
PC-1369-5	PC-710-5	5
PC-1369-6	PC-710-6	6

*Normally supplied in Black colored cord. For other colors add suffix to Model No.: W, white; R, red; G, green; BR, brown.

19" RACK PANELS

Two types of rack panels are offered by Langevin, Mat Panels and Instrument Panels. Mat Panels are made of 16 gauge steel, bonderized (rust-proofed) with 19/64" lips formed top and bottom to give proper clearance for mounting frame retaining screws. Rolled edges mate neatly with Instrument Panels which are 3/16" thick aluminum. Mat Panels have

standard mounting hole spacing and are furnished with chrome finish binder head screws and spacers. Instrument Panels have standard EIA (WE) notching. In addition to Langevin dark gray baked enamel Instrument Panels are offered also in Langevin light gray and unpainted. These panels are carefully made and well finished.

Sizes: 19" By	16 GAUGE STEEL RACK MAT PANELS			3/16" ALUMINUM INSTRUMENT RACK PANELS				
	Langevin Dark Gray			Unfinished			Langevin	
	Model	Shpng. Weight		Model	Shpng. Weight		Light Gray	Dark Gray
	Model	Model		Model	Model		Model	Model
1 3/4"	MP-31-B	1 lb.		RP-31-U	1 1/4 lbs.		RP-31-LG	RP-31-DG
3 1/2"	MP-32-A	1 lb.		RP-32-U	1 1/2 lbs.		RP-32-LG	RP-32-DG
5 1/4"	MP-33-A	2 lbs.		RP-33-U	2 1/4 lbs.		RP-33-LG	RP-33-DG
7"	MP-34-A	3 lbs.		RP-34-U	3 1/2 lbs.		RP-34-LG	RP-34-DG
8 3/4"	MP-35-A	4 lbs.		RP-35-U	4 1/4 lbs.		RP-35-LG	RP-35-DG
10 1/2"	MP-36-A	5 lbs.		RP-36-U	5 1/2 lbs.		RP-36-LG	RP-36-DG
12 1/4"	MP-37-A	5 1/2 lbs.		RP-37-U	6 lbs.		RP-37-LG	RP-37-DG
14"	MP-38-A	6 lbs.		RP-38-U	7 lbs.		RP-38-LG	RP-38-DG

JACK STRIPS

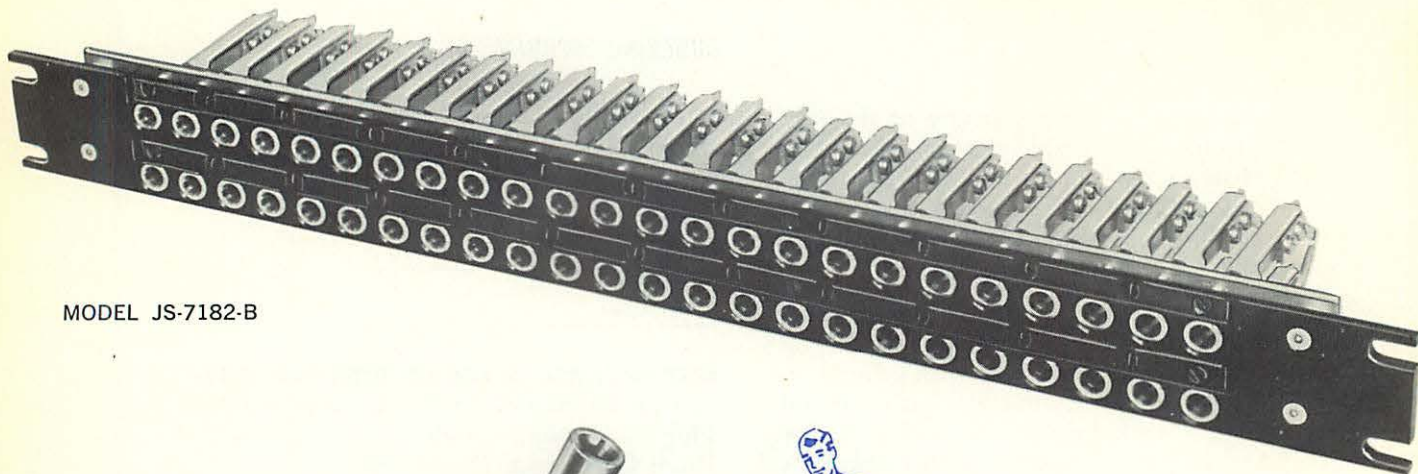

MODEL JS-7182-B

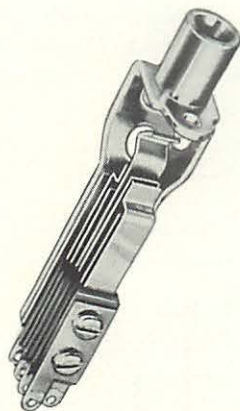

MODEL J-1399-BN



APPLICATION

Langevin Jack Strips are designed for use in consoles and equipment racks. They give rapid isolation, monitoring and selection of individual amplifiers for test. The use of jack strips also permits "patching" of various program sources to selected monitoring, remote or audition channels, as well as providing the ability to insert pads, equalizers, VU meters and other equipment optionally into any line.

DESCRIPTION

Langevin Jack Strips have black nickel plated panels, strongly reinforced with plated steel members. Mounting ears facilitate installation on standard relay racks and cabinets. Designation strips with clear plastic covers are standard on Langevin Jack Strips, and on both single and double row strips are directly over the respective rows, a unique feature which eases patching and avoids confusion. Importantly, the height of both single and double Langevin jack strips is $1\frac{3}{4}$ ", a proper rack multiple, unlike telephone company strips which are non-standard $2\frac{1}{8}$ " height.

Langevin Jack Strips are available with Model J-1399-BN double circuit, tip normal jacks, or may be supplied without jacks so that any of the jack types listed may be employed, including tip, ring and sleeve

Model JS-7160 and JS-7180 series jack strips afford the use of the conventional double plug, Langevin Model P-1367, with two tips and two sleeves. Jack mounting holes are spaced $\frac{5}{8}$ " apart horizontally, and accept not only Langevin Model P-1367 double plugs, but WE 241-A double plugs in addition. Double

plugs can be inserted into any two adjacent jacks, but not vertically. All jack sleeves contact the strip panel. Panel is standard $\frac{3}{16}$ " thick.

ORDERING INFORMATION

- Model JS-7161** Single Row Jack Strip, less jacks, 12 pairs of holes, size $19" \times 1\frac{3}{4}"$ with $\frac{3}{16}"$ mounting panel, slotted for standard rack mounting, with designation strip and plastic covers. Weight, Net, 1 lb.; shipping, 2 lbs.
- Model JS-7160** Double Row Jack Strip, less jacks, 24 pairs of holes, size $19" \times 1\frac{3}{4}"$ with $\frac{3}{16}"$ mounting panel, with designation strips and plastic covers. Weight, Net, $1\frac{1}{4}$ lb.; shipping, 2 lbs.
- Model JS-7181-B** Single Row Jack Strip, same as Model JS-7161 but with Model J-1399-BN 2 circuit tip normal jacks and designation strip. Weight, Net, 2 lbs.; Shpg., $2\frac{1}{2}$ lbs.
- Model JS-7182-B** Double Row Jack Strip, same as Model JS-7160 but with Model J-1399-BN 2 circuit tip normal jacks and designation strips (2). Weight, Net, $2\frac{1}{2}$ lbs.; Shpg., 3 lbs.
- Model DS-1219** Designation Strip, for above Jack Strips,

JACK STRIPS



TIP RING AND SLEEVE JACK STRIP AND JACK ASSEMBLIES

To conserve space in the jack field and to simplify patching, the tip ring and sleeve jack strip and jack assemblies shown here are available with complementary combination spacer and designation strips. These assemblies are stocked only in 3 circuit tip and ring normal configurations on the jacks, (same circuit as J-7111-B) but may be ordered special in other forms. Any number of units may be stacked.

ORDERING INFORMATION

All jack strips and designation-spacer strips are 10 15/32 inch long across the face and mount 2 holes on 11 inch centers with length 11 15/32 inch overall. Width of each is 1/2 inch, depth of jack and jack strip assembly is 3 inches.

JS-7191 Designation Spacer Strip, for JS-7192 or JS-7193 Jack Strip and Jack Assemblies. Includes mounting screws. Weight, Net, 3 oz.; shipping, 1/4 lb.

JS-7190 SPACER STRIP, same as above but without designation holder.

JS-7192 Jack Strip and Jack Assembly, with 10 3 circuit tip and ring normal jacks integrally mounted. Uses P-607 Plug. Includes mounting screws. Weight, Net, 8 ozs.; shipping, 3/4 lb.

JS-7193 Jack Strip and Jack Assembly, same as above but 20 jacks. Weight, Net, 1 lb.; shipping, 1 1/4 lb.

TELEPHONE SWITCHBOARD JACKS

Langevin Jacks are the preferred long frame type, designed especially for highest quality communica-

tion equipment at low levels of operation. The rugged nickle plated steel frame is press welded to provide dimensional stability. Springs are especially fabricated of long wearing, rust-free nickle alloy guaranteeing maximum life and corrosion resistance. This jack uses cross-bar palladium contacts in all switching circuits. The circuits listed are those common to most console and rack transmission equipment, but more complex circuits are available on order.

Frame and Stack screws are cadmium plated steel with iridescent irridite dip. Springs are formed of spring tempered nickle-silver alloy with lugs hot tin dipped. Bushings in the stacks are half-hard brass and bright nickle plated. Insulation is effected by high quality XXXP phenolic spacers, (Type PBE-D per Mil-D-3115-A) with phenolic tubing employed in the stack.

Model No.	Schematic Circuit	Height, Max.	Remarks
J-1399-AN		7/16"	2 Circuit, for double plugs.
J-1399-BN		1/2"	2 Circuit tip normal, for double plugs.
J-7111-A		9/16"	3 Circuit for single tip ring & sleeve plugs.
J-7111-B		5/8"	3 Circuit tip & ring normal for single tip ring & sleeve plugs.

LANGEVIN TELEPHONE TYPE SWITCHBOARD KEYS

Langevin Series KY-1044 Telephone Switchboard Type Keys find invaluable application in transmission work, especially on console control panels. They are used for transferring one part of a circuit to another, for cueing, "keying" in effects filter and preset equalizers, for operating signal lights, relays, talk-back circuits, and are employed over mixer positions to allow keying in the circuit on demand. In addition, the 3 position key permits a choice of two inputs for each preamplifier and mixer.

Langevin keys are rugged, reliable, well constructed assemblies, the frame of which is formed of heavy, press-welded steel stampings. Nylon rollers actuate the nickel silver springs and provide smooth, positive action. Long springs without forms at the point of flexing insure dependable spring life. These springs each terminate in tinned solder lug terminals. Cross-bar contacts are palladium; these are rated 3 amperes at 120 vac non-inductive load.

The springs in Langevin 3 position key switches are operated by a lever which has 3 positions normally, the center being the unoperated position. In position 1, the lever operates only the springs on the associated side, and in the opposite position 2 operates only the springs associated with that side. Normally keys shipped locking in both positions can be adjusted by the user to be non-locking in either or both positions if desired.

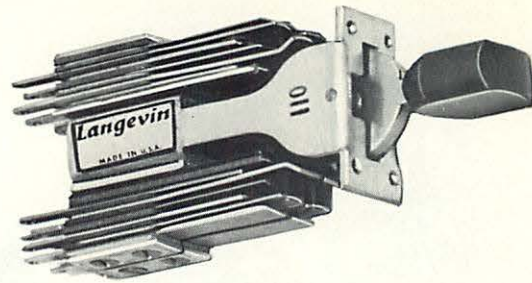

Langevin Lever Type Keys are listed below in standard spring and circuit configurations, two and three positions, but unusual requirements may be ordered by referring to the Table of Basic Forms and requesting the circuitry desired for both positions 1 and 2.

Round, black bakelite key handles are supplied with each switch, but WE Type Tab Handles, Langevin Model K-115, are available as an additional accessory. These are normally supplied in black, but are available in colors also by specifying W, white; R, red; OR, orange; Y, yellow; GR, green; B, blue; P, purple and GRY, gray.

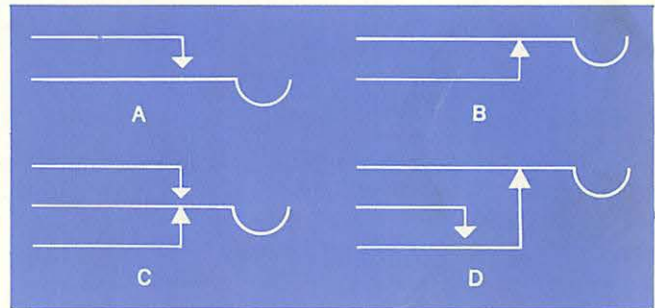

NOTE: When "B" Contacts are required use a key with the number of "C" Contacts needed. "C" Contacts may be wired for either "A" or "B" function.

ORDERING INFORMATION

— TWO POSITION KEYS

LOCKING IN ALL POSITIONS	NON-LOCK IN ONE POSITION	CONTACT ARRANGEMENT (ONE SIDE)	HEIGHT OVER CONTACTS
KY-1044-A	KY-1044-AN	2A	1"
KY-1044-E	KY-1044-EN	2C	1"
KY-1044-G	KY-1044-GN	4C	1½"
KY-1044-O	KY-1044-ON	2D / 1A	1⅛"
KY-1044-P	KY-1044-PN	4D	1⅛"
KY-1044-X	—	8C	2"

THREE POSITION KEYS

LOCKING IN ALL POSITIONS	NON-LOCK IN ONE POSITION	NON-LOCK IN TWO POSITIONS	CONTACT ARRANGEMENT		HEIGHT OVER CONTACTS
			UPPER	LOWER	
KY-1044-B	KY-1044-BN	KY-1044-B2N	2A	2A	1⅜"
KY-1044-F	KY-1044-FN	KY-1044-F2N	2C	2C	1⅜"
KY-1044-H	KY-1044-HN	KY-1044-H2N	4C	4C	1⅞"
KY-1044-S	KY-1044-SN	KY-1044-S2N	2D	2D	1½"
KY-1044-M	KY-1044-MN	KY-1044-M2N	4D	4D	1⅞"
KY-1044-R	KY-1044-RN	KY-1044-R2N	2D / A / B	2D / A / B	1½"
KY-1044-Y	—	—	4D / 1A	4D / 1A	2"

KEY STRAPPING

For the convenience of its customers Langevin shows here the employment of various keys in switching both monophonic and stereo-phonetic circuits. The small schematic at each drawing shows function. All wiring is pictured from the rear of the key. A circle around two wires denotes a shielded pair. A twisted unshielded pair may be used if it is less than 6 inches long. Jumper straps less than 2 inches long

need not be twisted. All pairs should be color coded to carry through proper phasing.

Note that both signal wires are switched at all times; this is an important requirement in the prevention of ground loops. All transfers are shown with load resistors in place for circuits of standard 600 ohms impedance.

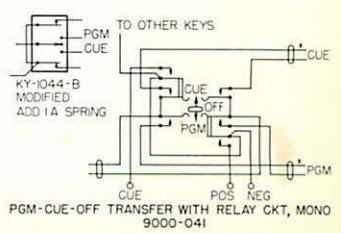
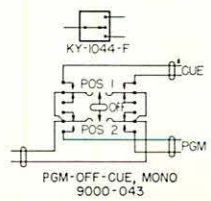
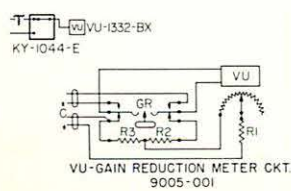
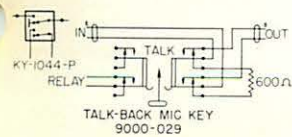
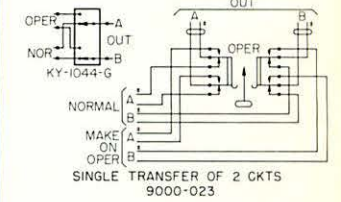
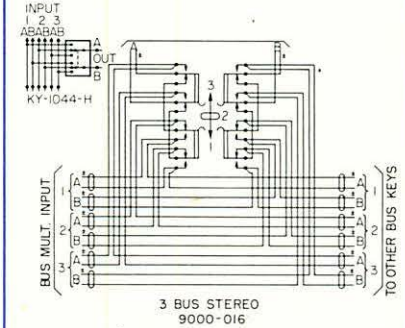
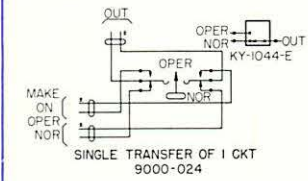
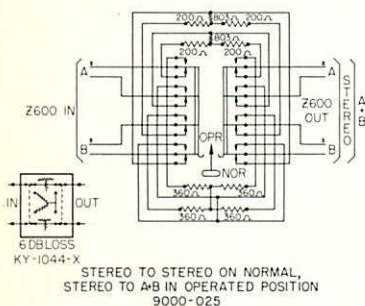
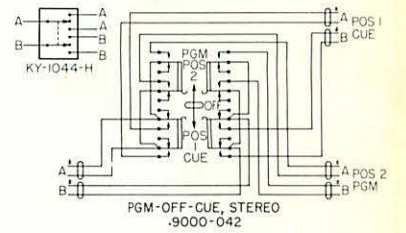
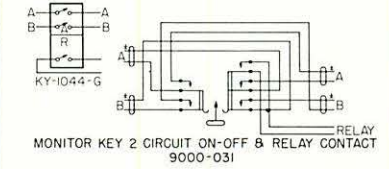
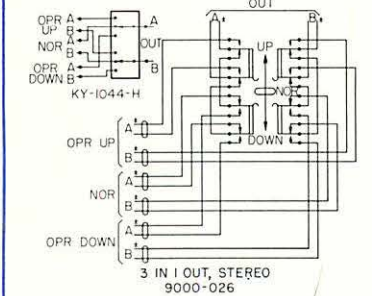
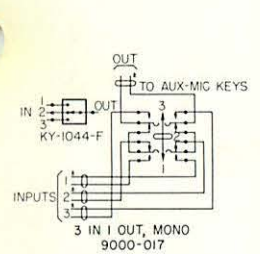
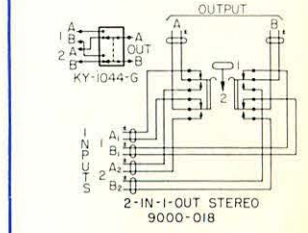
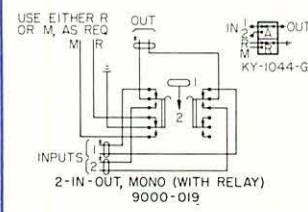
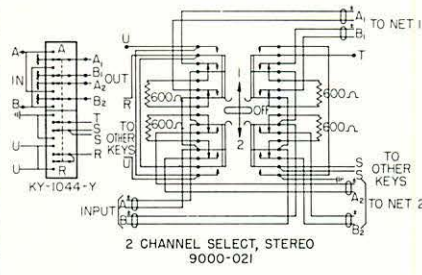
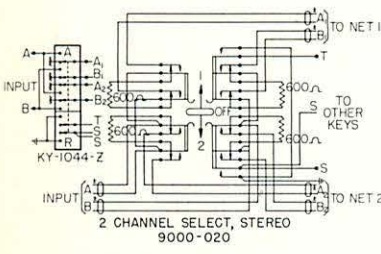
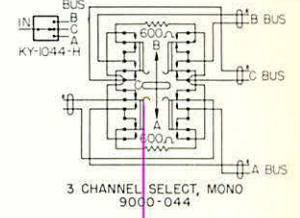
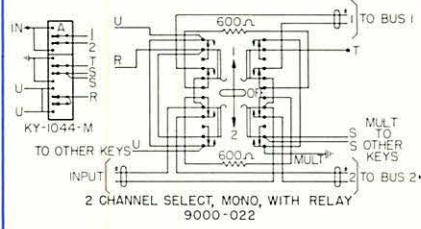
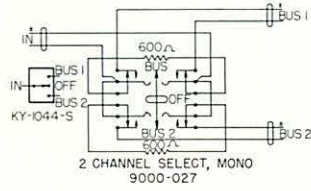
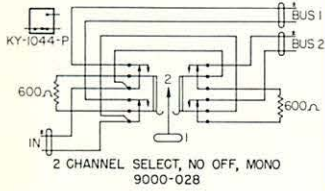

Here are the things you should consider in choosing VU METERS—

The considerations in the choice of a monitoring instrument for music and voice frequency powers are fairly complex and seldom engaged in. These points are discussed briefly so that proper weight may be given to their importance:

Frequency Response — The reading should be constant regardless of the frequency range from 20 to 15 kcps. In addition to monitoring the program material, the VU Meter is also called upon to measure system response linearity during routine maintenance. Many VU Meters are inaccurate in this respect, varying 7 and 8 db at the high end of the spectrum particularly.

Accuracy Because of the advent of stereo in 2 and 3 channel array, critical balance from channel to channel during operation is of prime importance. These meters are accurate within .2 db over the prominent portions of the scale. Most VU meters depart far from this. Vernier adjustments consisting of Langevin Model VR-111 500 ohm series variable wire wound resistors permit accurate adjustment for correlation.

Ballistics — Two things happen in all meters to confuse readings. Peaks reached on transient signals are 10 db higher than the meter movement can follow. The best VU meter averages the peaks. To do this high magnetic damping is required so that speed of action is not sacrificed as in mechanical damping. Inferior meters are too slow in action for accurate readings because of mechanical damping employed at sacrifice of large, more costly magnet structure. To gain even reasonable speed mechanical damping must be reduced to a value which causes pointer overshoot and erratic, hard-to-read action.

GENERAL DESCRIPTION — The Weston meters and Langevin meter panels listed here are used for the measurement of noise level and other audio frequency energy where the established dynamic characteristics give a common result for measurements and levels established in different laboratories and on different consoles.

These meters are designed for use with an external 3600 ohm resistance between them and the line. In meter panels, a 500 ohm variable wire wound resistor with a slotted shaft is employed in series with a 3300 ohm resistor or with a rotary attenuator to permit calibration, along with extending the range of the meters to higher levels of operation.

For recording consoles and equipment racks the "A" scale is employed as standard. This scale reads predominately in VU, with percentage of modulation appearing below the line of the VU scale. For broadcast use the "B" scale is available when so ordered, and shows percentage of modulation on top of the scale line.

Features — Meets ASA Standards. ASA Standard C16.5 dated 1954 is complied with fully.

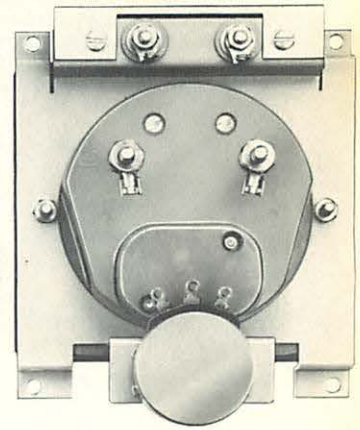
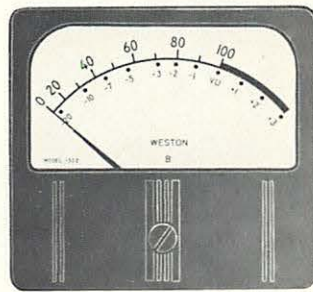

MODEL VU-1332
VU METER

Highest Sensitivity. Both types of meters described here incorporate a special copper oxide rectifier and a highly sensitive movement employing a stable, well shielded, Alnico V magnet of exceptional weight. This "CORMAG" construction permits the use of the meter on either aluminum or steel panels without affecting the calibration.

Large Easy-to-Read, Illuminated Scale. — A 6.3V panel lamp illuminates the scale of the VU-1332-BX meters against a non-halation buff colored field, and provides a shadowless background which eliminates confusion in readings. VU Scale is supplied in prominent black figures with an underline in black dividing the VU from the percentage of modulation underneath. VU designations from 0 to +3 VU are printed in red in the overshoot area.

Connections. — These VU meters use a total external series resistance of 3600 ohms, and when so connected across a 600 ohm line and load, a 1000 cps sine wave of 1.228 volts applied to the instrument and series resistor will cause the meter to read "O" VU. This value represents 4 db above 1 milliwatt in a 600 ohm line, the standard level used in most transmission practice. A Langevin step-type, constant impedance attenuator of 3900 ohms, calibrated in VU may be inserted between the external resistances and the meter to read higher line levels, thus serving as an extension of the reading above +4 VU. These extensions are covered in the Attenuator Section of this catalogue.

Two Classes of Meters Are Offered. — Two classes of meters are offered by Weston, but only the VU-1332 series is stocked and sold by Langevin.

The 1332 unit has a scale 3/16 in. shorter than the larger Weston meters, no teardrop on the pointer, and is almost 4 in. wide by 3.5 in. high by 1.5 in. deep. The "Cormag" movement, like the larger meter, meets ASA standards, a feature of vital importance, for this fact sets these meters apart from all others. When sold as a separate unit, the 1332 is not illuminated. Langevin has standardized on this meter for its VU Panels with rear mounting hardware and modifications which provide illumination.

The high advantage of the 1332 type meter is that it provides a modern instrument as modified, with no sacrifice in performance, at approximately one-half the cost of the 862-962 Weston Series which Langevin does not stock. The absence of the teardrop on the pointer, Langevin feels, is more than offset by the greatly reduced cost; the difference in scale length is insignificant.

VU METER PANELS

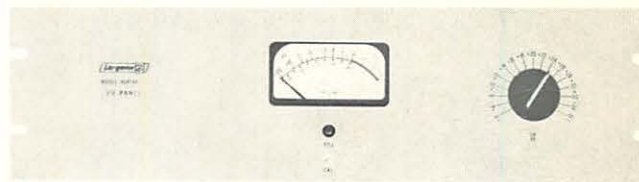

MODEL VUP-34

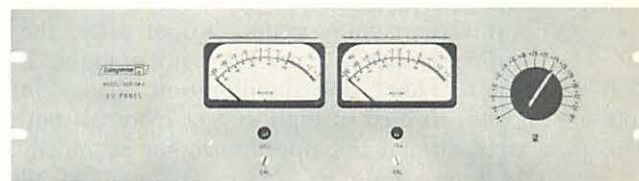

MODEL VUP-34-2

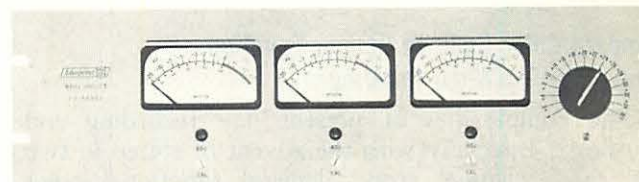

MODEL VUP-34-3

METER PANELS — Langevin Illuminated VU Meter Panels come in standard 19" rack widths and 5¼" height. These are available from stock in 1, 2 and 3 meter configurations. Panels are 3/16" aluminum finished in Langevin gray with standard WE notching. Each Model VU-1332 BX meter has an extension attenuator, and is equipped also with VR-111 500 ohm wire wound variable resistor for calibration and balance. Terminations are on Jones terminal blocks.

Model	Range	Steps VU	Price, Net	Double Model	Price, Net	Triple Model	Price, Net
VUP-24	+4 to +24-off	2	\$83.00	VUP-24-2	\$149.00	VUP-24-3	\$215.00
* VUP-34	+4 to +34-off	2	85.00	VUP-34-2	153.50	VUP-34-3	223.00
VUP-44	+4 to +44-off	2	88.50	VUP-44-2	156.50	VUP-44-3	226.00
Weight			Net, 6 lbs. Shipping, 7 lbs.		Net, 7 lbs. Shipping, 8 lbs.		Net, 8 lbs. Shipping, 9 lbs.

* Preferred Model

SPECIAL VU PANELS TO ORDER

Combinations of VU meters and Gain Reduction Meters can be ordered in one, two and three channel arrays; include Limiter Accessory Controls if desired with your order. Prices and details available on request.

RECOMMENDED ACCESSORIES

Model FTM-1 — 0 to 1 db adjust pad in .1 db steps, for VU Meter,

Model FTM-12
Meter Multiplier Network consisting of combination 3600 ohm resistors and fixed 3900/3900 ohm "T" Networks for extending range of VU Meter.

Model FNVU-4 — "T" Pad for Meter Bridging to read +4 VU, 7000 - 7500/3900 ohms.

Model VR-111 — 500 ohm Variable Wire Wound Resistor for balance and calibration; screwdriver slot adjustment.

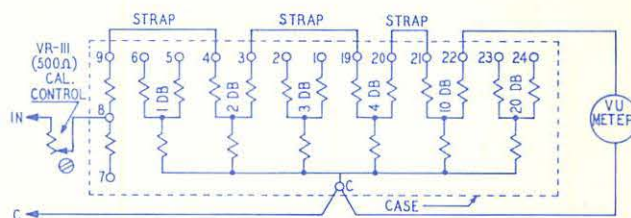

ORDERING INFORMATION

All meters are supplied with "A" scale unless otherwise specified.

Model VU-1332 VU Meter, 4" high by 3½" wide by 1½" deep, non-illuminated. Weight, Net, ¼ lb.; Shipping, 1 lb.

Model VU-1332-BX VU Meter, same as above but illuminated; modified for rear panel mounting; includes VR-111 calibration control and frosted pilot lights. Weight, Net, ½ lb.; Shipping, 1 lb. (Specify if gain reduction decal is desired on meter face.)

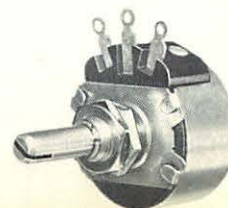

MODEL VR-111

Standards of the motion picture, recording and TV-Broadcast industry are the RCA type knobs.

Langevin RCA type knobs are provided in standard functional transmission color codes. Importantly, the blue color, ordinarily sensitive to UV and sunlight, is highly resistant to fading and discoloration. Langevin knobs are rugged; formed of high impact material they retain their strength and fine appearance for an indefinite length of time. Two set screws are used on all types to insure positive, non-slip gripping action. No flats are required on control shafts.

Standard Color Code to Denote Function — Please Specify When Ordering

The complexities of present day recording and broadcast, especially with the advent of stereo in two and three channel array, demand functional color coding of controls to ease the task of the mixer or engineer during intense sessions. Standard color coding related to function is as follows:

Control and Approximate Level	Color
Microphone Mixers and Associated Keys (— 55 dbm)	Blue
Remote Input Mixers, Turntables	
Limiters, Metering, VU Range Extenders and Associated Keys (— 20 to + 10 dbm)	White
Equalizers and Associated Keys (— 40 to + 20 dbm)	Black
Submaster Controls and Associated Keys (— 40 to 0 dbm)	Green
Master Controls (— 30 to + 24 dbm)	Red
Pan Pot Controls	Red
Monitor Controls (Power Levels)	Yellow

Pan Pot Dials, Stereo VU Meter Designations, Stereo Switching

Recordist Right (Stage Left)	Blue
Center	White
Recordist Left (Stage Right)	Red
TV Functions (Not completely standardized)	Orange
	Gray
	Purple

DESCRIPTION AND ORDERING INFORMATION

Langevin RCA Type Knobs

This knob has become almost the universal standard as a mixer knob. The upper portion of the knob has 8 gentle detents to provide gripping action. An extension of the indicator line follows down the side of the knob out to the edge of the skirt on a protrusion of the knob body. This assists in positioning the knob in the dark by feel with the index finger. The shape of the knob as it joins the skirt provides a recess for the rest of the fingers and is comfortable when gripped by the hand.

Model K-108 RCA Type Mixer Knob; size is 2 1/16" diameter by 1 1/4" high. Accepts standard shaft .250 diameter and comes complete with 2 Allen 8/32 set screws. Normally supplied in black unless otherwise specified. Weight, Net, 3 ozs.; shipping, 1/4 lb.

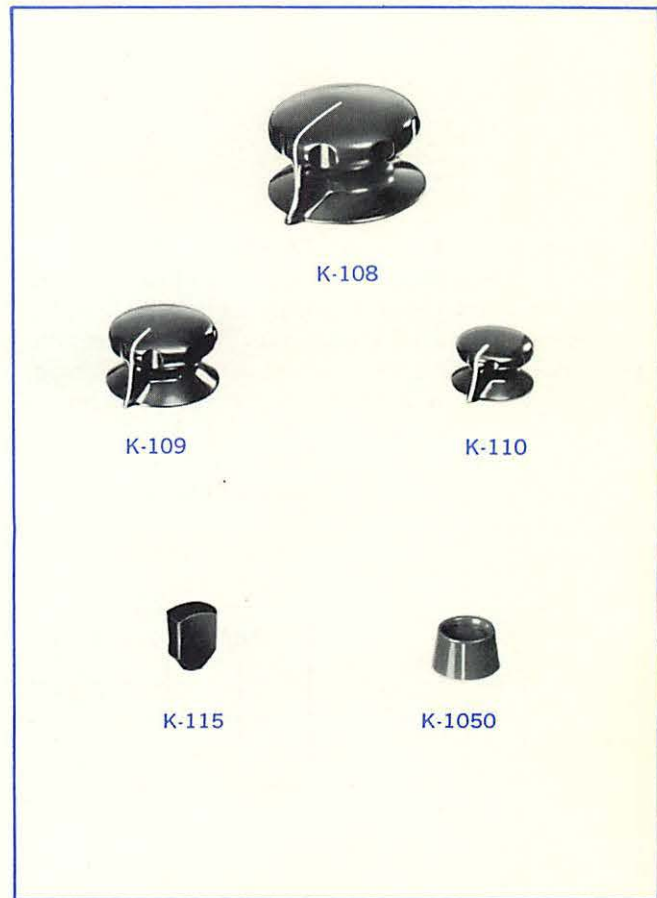

Model K-109 RCA Type Instrument Knob; same as K-108 above but 1 7/16" diameter by 3/4" high; suitable for use as a small mixer knob. Normally supplied in black unless otherwise specified. Weight, Net, 1 oz.; shipping 1/4 lb.

Model K-110 RCA Type Instrument Knob: same as K-109 above but 1 1/16" diameter by 5/8" high and set screws are 6/32. For use as calibration control knob, or anywhere when space is at a premium. Normally supplied in black unless otherwise specified. Weight, Net, 1 oz.; shipping, 1/4 lb.

Model K-115 WE Type Key Tab; handsome tab type key handle, detented sides for non-slip finger control. Has 4/40 Allen set screw. Used on all standard keys and certain Langevin equipments. Size is 25/32 inch long by 3/8 inch wide by 3/8 inch thick. Normally supplied in black unless otherwise specified. All standard colors available and also in Video gray, orange and purple.

Model K-1050 Knob; for Langevin Straight Line mixers. Size is 3/4 inch diameter by 1/2 inch high; uses 4/40 Allen set screw. Index line scribed on both sides. Supplied in RED unless otherwise specified. Weight, Net, 1 oz.; shipping, 1/4 lb.

KNOB AND DIALS

DIALS

These dials are fine appearing precision plates fabricated of $\frac{3}{32}$ inch thick aluminum so that the component mounting screws will be flush with the dial face. They are anodized in flat black non-halation satin matte finish. Markings are etched with modern lettering and figures specially designed by Langevin. Center hole mounting in all dials is $\frac{3}{8}$ " clearance. On the $2\frac{1}{4}$ " diameter dials two mounting centers are available, $1\frac{1}{4}$ " and $1\frac{3}{8}$ ". The $2\frac{3}{4}$ " dial has $1\frac{1}{4}$ ", $1\frac{3}{8}$ " and $1\frac{1}{2}$ " mounting centers. Mounting holes are countersunk. Blank dials are also available to be engraved either by the customer or by Langevin.



D-1001 (B-850)



D-1002 (B-828)



D-1002 (B-843)



D-1002 (B-827)



D-1002 (B-829)

MODEL	DIAMETER	DIAL MARKING	MOUNTING CENTERS	MOUNTING HOLE CLEARANCE	MODEL	DIAMETER	DIAL MARKING	MOUNTING CENTERS	MOUNTING HOLE CLEARANCE
D1001(1960)	2¼	Blank	CHM	None	D1002(2440)	2¾	Blank	1¾	6:32
D1001(850)	2¼	Blank	1¼	6:32	D1002(843)	2¾	Blank	1½	8:32
D1001(2428)	2¼	Blank	1¾	6:32	D1002(2441)	2¾	20 step mixer	CHM	None
D1001(2429)	2¼	20 step mixer	CHM	None	D1002(2442)	2¾	30 step mixer	CHM	None
D1001(2430)	2¼	30 step mixer	CHM	None	D1002(2443)	2¾	32 step mixer	CHM	None
D1001(2431)	2¼	32 step mixer	CHM	None	D1002(2444)	2¾	45 step mixer	CHM	None
D1001(2432)	2¼	45 step mixer	CHM	None	D1002(829)	2¾	20 step mixer	1¼	6:32
D1001(2019)	2¼	20 step mixer	1¼	6:32	D1002(2445)	2¾	30 step mixer	1¼	6:32
D1001(2433)	2¼	30 step mixer	1¼	6:32	D1002(827)	2¾	32 step mixer	1¼	6:32
D1001(2017)	2¼	32 step mixer	1¼	6:32	D1002(2446)	2¾	45 step mixer	1¼	6:32
D1001(2434)	2¼	45 step mixer	1¼	6:32	D1002(2447)	2¾	20 step mixer	1¾	6:32
D1001(2435)	2¼	20 step mixer	1¾	6:32	D1002(2448)	2¾	30 step mixer	1¾	6:32
D1001(2436)	2¼	30 step mixer	1¾	6:32	D1002(2449)	2¾	32 step mixer	1¾	6:32
D1001(2437)	2¼	32 step mixer	1¾	6:32	D1002(2450)	2¾	45 step mixer	1¾	6:32
D1001(2438)	2¼	45 step mixer	1¾	6:32	D1002(2451)	2¾	20 step mixer	1½	8:32
					D1002(2452)	2¾	30 step mixer	1½	8:32
D1002(2439)	2¾	Blank	CHM	None	D1002(2453)	2¾	32 step mixer	1½	8:32
D1002(828)	2¾	Blank	1¼	6:32	D1002(2454)	2¾	45 step mixer	1½	8:32

For price information, see price sheet appended.

ENGRAVING CHARGE

9 cents for each letter, character or numeral; indicator line counts as letter. Arrows 9 cents per lineal inch including point and tail. Drawing must

accompany order showing degrees spacing, size of characters and all diameters. If dial is for Langevin product no drawing is required if product is specified.

Equalizing for Spectral Character

The Recording Engineer is Vitrally Concerned With 5 Things

1. *Musical Range*—The equipment with which the recording engineer works is capable of reproducing almost the entire world of sound—a range of nearly 10 octaves, embracing vibrations from 20 to over 16,000 cycles or beats per second. But certain restrictions are imposed on the recordist in accomplishing this totality, both physical and practical ones. These restrictions can be overcome to a high degree by *equalization*.

2. *Rhythm*—The framework of the musical performance is *rhythm*. While control of rhythm would seem to lie solely in the domain of the performers, the engineer is charged with the interpretation of rhythm by controlling bass and mid-bass balance to the rest of the sound. This is accomplished by choosing and placing the microphones, regulating their intensity, and influencing their spectral sensitivity through *equalizers*.

3. *Variety*—The brain, through the ear, delights in variety. It follows that the widest range accompanied by best spectral balance, delivers the most auditory pleasure. Through good judgement, and careful regulation of the microphones by means of their volume and equalization controls, the recording engineer insures maximum listener enjoyment.

4. *Dynamics*—The transition in music from a soft passage to a louder one is calculated by most composers to achieve a physiological effect. While the ear perceives a dynamic range of one in a trillion (120 db), the recording engineer must limit this to one in a million (60 db) for this is the maximum capability of present day equipment. To accomplish this compression unnoticeably requires skill at the volume controls with the help of equalizers; the spectral sensitivity of the ear changes when the volume level is varied from that of the original performance.

5. *Spectral Control*—This is a descriptive name for the term "equalization." It implies the option to raise or lower the intensity of critical sections of the musical range. Further, it connotes a subjective appreciation of the physiological effects achieved through these means to compensate for the limits of the recording and reproducing equipment. Here, more than in any other function of the recording engineer, lies the highest, most sustained expression of the recordists art.

The Critical Portions of the Audible Spectrum Requiring Spectral Control

**VERY LOW BASS —
POWER RANGE — 16-64 cps
1st and 2nd Octaves**

In this region, from 16 to 64 cycles per second, we find the threshold of feeling, where the lowest sounds, like wind and room effects—the sound of distant thunder—are felt, rather than heard. In the upper half of the first octave, just below 32 cps, J. C. Stienberg[Ⓢ] shows that the fundamentals of the piano, organ and harp, reach well into this range; he shows also that the memory of the ear for these lowest sounds is long—they need occur but seldom in a three or four minute passage to achieve feeling of power and fullness, to balance aesthetically what would otherwise be a preponderance of higher tones.

But Fletcher has charted the sensitivity of the ear for various parts of the spectrum at lower than the levels of real existence. His compensation requirement for equal loudness in this range at lower recorded and reproduced levels shows requirements for tremendous boosts, on the order of 10, 20 and 30 db, or anywhere from 10 to 1,000 times.

Precise control of this range is required to subdue stage rumble and outside traffic noise, an acute problem in New York Studios. Overemphasis through microphone placement, especially those ribbon microphones which are velocity sensitive, can muddy the sound. The option to attenuate this range is as important as the ability to boost it.

**BASS — RHYTHM AND MUSICAL FOUNDATION
3rd and 4th Octaves — 64-256 cps**

Most of the low, grave tones of the drum and piano are generated in this range; here we find the fundamentals of the rhythm section of the dance orchestra, as well as the foundation of all musical structure.

It was Leopold Stowkowski who said "If I had a thousand bass viols I could use them all!"—This is not as extreme as it may sound. For instance, such string instruments, while reinforced by sounding boards, generally play single tones, weak in level and possess little dynamic range. In a large, comprehensive orchestra, as many as eight bass viols may be used. A total of 1,000 bass viols in this case would give only an additional 21 db of level, a not inordinate amount if a glance be given to the equal loudness contours for the ear on the previous page. Profound attention should be given to equalization or attenuation in this range, for the musical balance of the entire program can be controlled at 100 cps.

Most pressure microphones are subject to "proximity effect," or non-linear bass increase at low frequencies in close talking positions. The use of attenuation for dialogue restores normal perspective and quality.

**MID-RANGE — 256 to 2048 cps
5th, 6th and 7th Octaves — "Telephone-Like" Quality**

The ear is reasonably sensitive in this range, and almost all

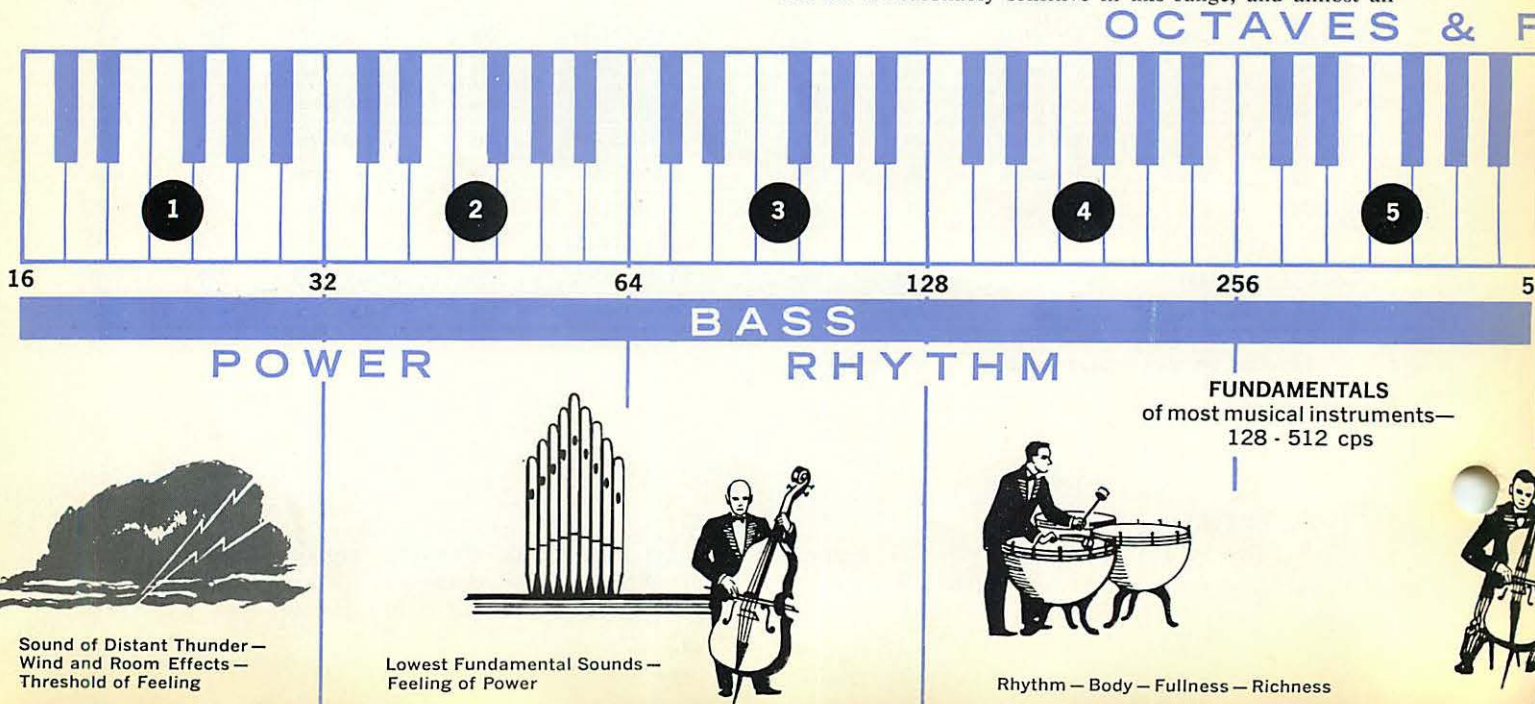

Sound of Distant Thunder—
Wind and Room Effects—
Threshold of Feeling

Lowest Fundamental Sounds—
Feeling of Power

Rhythm — Body — Fullness — Richness

recording and reproducing equipment manages this mid-range with facility.

If the 6th octave is made louder with respect to other octaves, the music has a horn-like character. If the 1000-2000 cps range is emphasized a "tinny" effect is achieved.

The fundamental tones in most music lie equally above and below middle C, from 128 to 512 cps. As most instruments are rich in the first overtones, the majority of the sound energy is found up to the 2,500 cps range. Music editors, and others engaged in listening to music over long periods find that "listening fatigue" can be reduced by attenuating the 5th, 6th and 7th octaves by about 5 db from the normal level.

LISPING QUALITY—
Between the 7th and 8th Octaves—3 kcps

The 3 kc range delivers a generous stimulus to the ear. At very loud levels the region of greatest ear sensitivity shifts downward from 5 kc, and accounts partly for the high sensitivity of most public address loudspeakers in the 3 kc band. Characteristic of low-level signals peaked at 3 kc is a "lispings" quality, and the total inability to distinguish labial sounds such as m, b and v.

In wide-range lower level systems, a peak in the region of 3 kc has a masking effect on important recognition sounds, and on others which lie above 4 kc. Brilliance and clarity are lost, and without attenuation an unconscious strain with increasing fatigue is felt according to the height of the 3 kc rise.

PRESENCE RANGE—
Between the 8th and 9th Octaves—4750 to 5 kcps

The usual band which affects clarity in a man's speech is 3,000-6,000 cps. In a woman's voice the fundamentals are roughly an octave higher than a man's, and her range of consonant clarity is achieved between 5,000 and 8,000 cps, a region the higher end of which approaches an insensitive range of the ear. In addition, the total range of a woman's voice is about one-half that of a man's, stimulating fewer hearing nerves, and is consequently still weaker upon reception for this reason.

Wide range sounds, especially those of singing voices, have fundamentals with harmonics in the 5 kc region of good ear sensitivity. Voices, powerful or rich with harmonics at 5 kc sound especially pleasing, clear and full. Male opera singers are particularly favored with 5 kc sounds, women less so, although there are notable exceptions. It follows that deficient voices, especially those of women, can be enhanced in listening value by a generous boost at the 5 kc point, on the order of 5 to 8 db. Definition is increased by added power given to the recognition sounds like t, s, ch and k. A collateral benefit of this boost is the apparent increase in level; a 6 db rise at 5 kc frequently gives an *apparent* increase of 3 db to the overall signal.

The attenuation of the 5 kc range on instrumentals can give a "transparent" quality to the performance, provided that it is otherwise wide-range. This quality is common to European orchestral recording, has found some popularity, and may be desirable. Usually, vocals on microphones with a "saddle" in

this range lack the "punch," or "presence" to which we have grown accustomed in this country.

BRILLIANCE—
Part of the 9th through the 10th Octave—6500 to 16000 cps

Unvoiced consonants attributed to tooth, tongue and lip sounds are high in frequency, and reach the 10 kc range. These frequencies account for some clarity and most brilliance, even though they purvey less than 2% of the total speech energy. The same effect holds true for musical instruments, and especially for percussion. Thus, in order properly to convey all the effects in recording independently of microphone placement and sensitivity in the last octave, the ability to boost this range in an easy, continuing slope on the individual microphone is helpful.

On some undamped microphones of the diameter of about one-half inch, an opposite correction is required, especially on speech and vocals. The extension of the higher range in good microphones exploits the "baffle" effect investigated by Mueller, Black and Davis in 1934. It has been determined that extra sound pressures build up on the diaphragm by a value of 9.8 db over an appreciable band, and that the predominant frequency of this band is directly associated with the diameter. In this way a microphone of 5/8 inch diameter is approximately one-half the wave length of 9 kc. On improperly damped microphones a distinct rise at this frequency is found which produces annoying sibilant distortion on speech. On Latin and other types of music using gourds and rattles, this peak results frequently in an astonishing and pleasing feeling of clarity.

HOW CONTROL IS ACHIEVED OVER GEOMETRY, TONALITY AND EFFECTS.

It would appear specious to suggest the multiplicity of corrections and precise control of spectral quality in the preceding without showing how it may be achieved. It is obvious that individual control of each microphone is needed for purposes of matching quality from left, center and right groups. It is plain to see that each microphone is confronted with the task of purveying qualitatively the sound from different instruments and artists, and that each microphone must be controlled throughout portions of its spectral range to accomplish special effects.

It has become good practice in monaural recording to provide a multiplicity of equalizers on the mixer console. In most cases this equalization has offered control at two points only, generally at 100 and 10,000 cps. While more control was desired, the unavailability of equipment small enough to provide more control and at other frequencies has in the past militated against needful additions.

With the advent of stereo and three-channel recording, nearly three times the equipment, with more elaboration, seems indicated, and expansion of console area in the horizontal plane offers the only direction in which to proceed. But a single engineer has arms only so long.

Succeeding pages describe Langevin Program Equalizers small enough to fit on the control panel over the mixer controls.

① J. C. Stienberg "Fundamentals of Speech, Hearing and Music."
② eg., Rosemary Clooney, Doris Day

FREQUENCIES

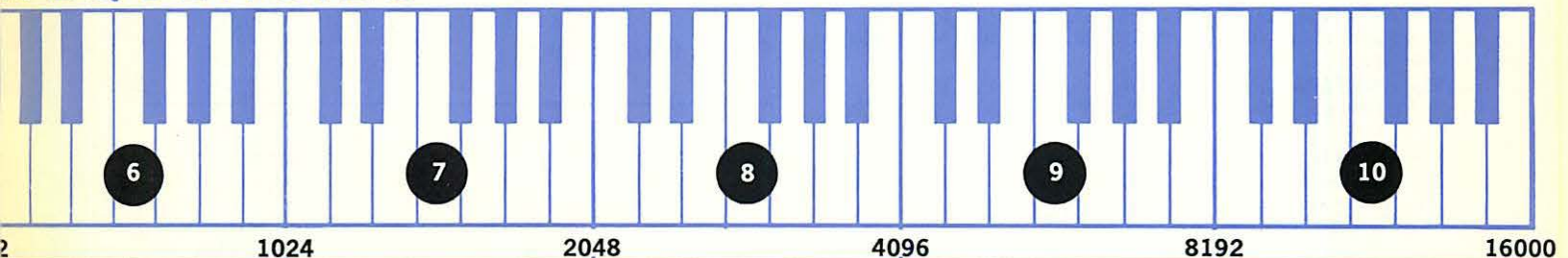

TREBLE

PRESENCE BRILLIANCE
- 5 KCPS

"HORN-LIKE"
Quality - 512-1024 cps

"TINNY"
effect - 1 kcps



Sounds Required for Bare Communication of Intelligence

"LISPING"
Quality - 3 kcps



Overtones—Realism—
Region of Labial and Recognition
Sounds in Speech and Singing



Brilliance—Sparkle—
Life-like Quality

MODELS EQ-255-A AND EQ-255-B VARIABLE HIGH PASS AND LOW PASS SOUND EFFECTS FILTERS

FEATURES

- Self-Contained:** Independent high and low pass units.
- Compact:** Uses no more space than a Rotary Attenuator.
- Versatile:** Tandem installation.
- Maximum Flexibility:** Overlapping cut-off frequencies.
- Flat response** except at cut-off points.
- Broad scope,** without hum or extraneous noise pickup.
- No phase distortion.**

The Langevin Models EQ-225-A and EQ-255-B High Pass and Low Pass Filters have been carefully engineered to combine the flexibility of a complete "sound effects" filter with the versatility afforded by independent, miniaturized units. This variable filter provides instantaneous selective band restriction over a wide range of transmitted sound. Independent controls for high and low frequency units, each equipped with eleven positions, including "OFF", allow overlapping of sound over the entire spectrum to produce a wide variety of possible sound effects. When several of these filters are used in tandem there is no insertion loss or distortion, and the curves will be additive.

TECHNICAL SPECIFICATIONS

EQ-255-A (HIGH PASS): 11 positions: "Off" - full frequency transmission. Cut-off frequencies: 70, 100, 250, 500, 1000, 2000, 3000, 4000, 5000, and 7500 cps.

EQ-255-B (LOW PASS): 11 positions: "Off" - full frequency transmission. Cut-off frequencies: 10000, 8000, 6000, 5000, 4000, 3000, 2000, 1000, 500 and 250 cps.

SWITCH AND BRUSH CONTACTS: Gold plated for low noise (-140 dbm)

CIRCUIT: Constant "K" of 600 ohms in and out

IMPEDANCE: 500 to 600 ohms. For other impedances use Langevin Model TF-602-C Transformers.

INSERTION LOSS: Zero

INPUT LEVEL:

Minimum: -70 dbm.

Maximum: +24 dbm.

CONNECTIONS: Solder terminals on rear with added case ground connection.

POWER EQUIPMENT: None.

MOUNTING: Three different mounting centers, 1 1/8", 1 1/4", and 1 1/2" on universal mounting bracket. Single 3/8" hole mounting also provided by removal of mounting bracket.

DIMENSIONS: 2 1/4" diameter by 4 7/8" long.

DIAL AND KNOBS: Dial is Model D-1002, 2 3/4" diameter, 1/32" thick aluminum, black satin anodized and engraved to suit.



HIGH PASS



LOW PASS



ORDERING INFORMATION

MODEL EQ-255-A HIGH PASS FILTER, complete with Model K-108 Instrument Knob and Model D-1002 engraved dial. Weight, Net, 1 1/2 lbs.; shipping, 3 lbs.

MODEL EQ-255-B LOW PASS FILTER, Complete with Model K-108 Instrument Knob and Model D-1002 engraved dial. Weight, Net, 1 1/2 lbs.; shipping, 3 lbs.

Model EQ-259-A Variable High and Low Pass Filter

Combines EQ-255-A and EQ-255-B High and Low Pass Filters on a single panel 3 1/2 ins. high by 19 ins. w by 5 3/4 ins. d; for rack mounting. Finish is Langevin light gray. Includes "in and out" key. Weight, Net, 4 1/2 lbs, 6 lbs shipping.

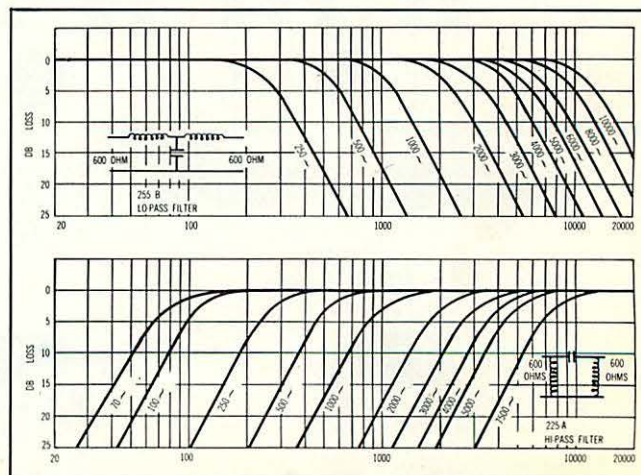

FIXED WAVE FILTERS

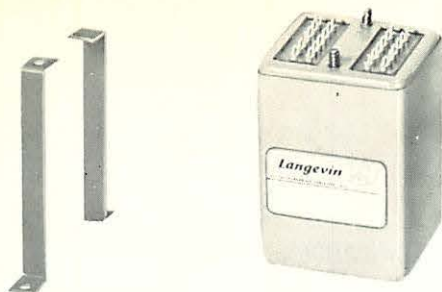

FIXED HIGH PASS FILTERS

These filters are applicable to audio frequencies only and will pass all frequencies above the cut-off (3 db down) point. Typical characteristics (shown below) have an attenuation of 16 db per octave. Toroidal coils are used to provide minimum hum pick-up and all components are "potted" for electrical and mechanical stability.

CIRCUIT: One full section constant K
CUT-OFF FREQUENCIES: 40, 50, 70, and 100 cps
IMPEDANCE: 600 ohms (unbalanced)
INPUT LEVEL: Minimum: -70 dbm; Maximum: + 28 dbm
MOUNTING: See Case "B," page 66
FINISH: Langevin gray baked enamel
DIMENSIONS: 1 7/8" w by 2 1/2" h x 1 3/4" d
NET WEIGHT: Approximately 1/2 lb
SHIPPING WEIGHT: Approximately 1 lb

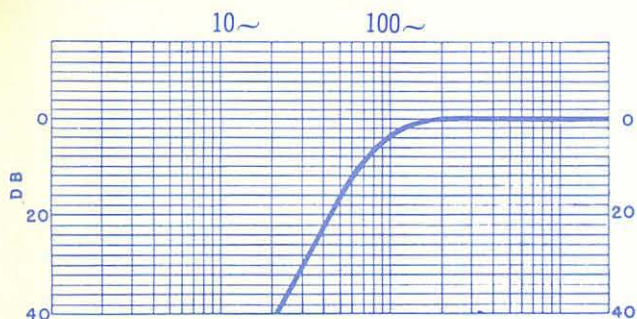

Available at 4 cut-off frequencies (See specifications.)
 Chart illustrates typical response using a 100 cps cut-off.

MODEL	CUTOFF
HP-40 HIGH PASS FILTER	40 cps
HP-50 HIGH PASS FILTER	50 cps
HP-70 HIGH PASS FILTER	70 cps
HP-100 HIGH PASS FILTER	100 cps

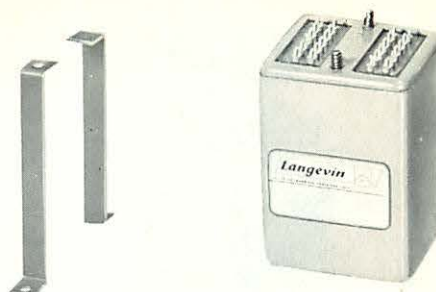

FIXED LOW PASS FILTERS

These filters pass all frequencies up to the cut-off point which is 3 db down on the attenuation curve. Typical characteristics (shown below) have an attenuation of 30 db at a point 10% above the cut-off frequency. Toroidal coils are used to provide minimum hum pick-up and all components are "potted" for mechanical and electrical stability.

CIRCUIT: One full section constant K and two m-derived half-sections.
CUT-OFF FREQUENCIES: 15, 12, 10 and 8 kcps
IMPEDANCE: 600 ohms (unbalanced)
INPUT LEVEL: Minimum -70 dbm; Maximum: +28 dbm
MOUNTING: See Case "B," page 66
FINISH: Langevin gray baked enamel
DIMENSIONS: 1 7/8" w by 2 1/2" h by 1 3/4" d
NET WEIGHT: Approximately 1/2 lb
SHIPPING WEIGHT: Approximately 1 lb

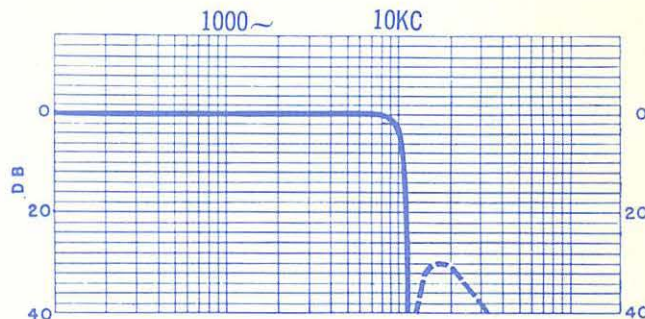

Available at 4 cut-off frequencies (See specifications.)
 Chart illustrates typical response using a 10,000 cps cut-off.

MODEL	CUTOFF
LP-15 LOW PASS FILTER	15 kcps
LP-12 LOW PASS FILTER	12 kcps
LP-10 LOW PASS FILTER	10 kcps
LP-8 LOW PASS FILTER	8 kcps

MODEL EQ-257-A RIAA EQUALIZER

USE: This instrument produces the desired RIAA curve characteristics and is used for playback of phonograph records.

IMPEDANCE: 600 ohms (unbalanced)
INPUT LEVEL: Minimum: -70 dbm; Maximum: + 28 dbm
MOUNTING: See Case "B" page 66
FINISH: Langevin gray baked enamel
DIMENSIONS: 1 7/8" w by 2 1/2" h x 1 3/4" d

INPUT LEVEL: Maximum: +24 dbm; Minimum: -60 dbm
INSERTION LOSS: 20 db at 1000 cps
EQUALIZATION: RIAA
NET WEIGHT: Approximately 1/2 lb
SHIPPING WEIGHT: Approximately 1 lb

UNIT TYPE VARIABLE EQUALIZERS



ELECTRICAL SPECIFICATIONS: All variable equalizers are Bridged "T" Networks providing constant impedance in and out. Available only in one impedance of 600 ohms for unbalanced line. Inductors are toroidal coils providing minimum hum pick-up. Precision resistors are used for stability and low noise level. All switching contacts are of a rugged design and of instrument quality using fine silver contacts and brushes.

GENERAL SPECIFICATIONS:

SWITCH AND BRUSH CONTACTS: Fine silver for low noise (-140 dbm)

CIRCUIT: Constant "K" of 600 ohms in and out

IMPEDANCE: 600 ohms. For other impedances use Langevin Model TF-602-C Transformers.

INSERTION LOSS: Zero

INPUT LEVEL: Minimum: -70 dbm

Maximum: +24 dbm

CONNECTIONS: Solder Terminals on rear with added case ground connection.

POWER REQUIREMENT: None

MOUNTING: Three different mounting centers, 1½", 1¼" and 1½" on universal mounting bracket. Single ⅜" hole mounting also provided by removal of mounting bracket.

DIMENSIONS: 2¼" diameter by 4⅞" long

DIAL AND KNOBS: Dial is Model D-1002, 2¾" diameter, 1/32" thick aluminum, black satin anodized and engraved to suit. Model K-108 RCA type knob is supplied.

MODEL EQ-260 3000 CYCLE VARIABLE EQUALIZER

USE: To provide additional response in the 3000 cycle region, to increase intelligibility and to provide corrective balance where lower frequencies are over-emphasized.

INPUT LEVEL: Maximum: +24 dbm; Minimum: -60 dbm

INSERTION LOSS: 8 db

EQUALIZATION: Maximum of 8 db at 3000 cps

STEPS: 8 steps of 1 db at 3000 cps

ROTATION: Clockwise for increasing equalization

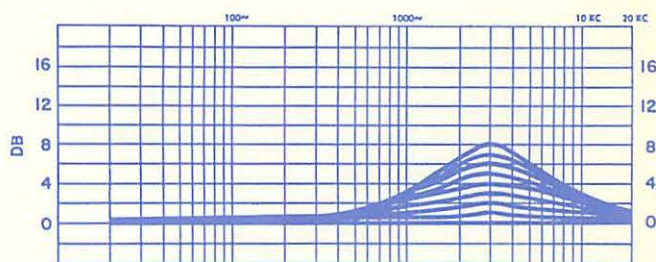

MODEL EQ-261 DIALOGUE-MUSIC EQUALIZER

USE: For reducing low frequencies on dialogue; diminishes room rumble, hum and other low frequency noise.

INPUT LEVEL: Minimum: -70 dbm; Maximum: +24 dbm

INSERTION LOSS: Zero

ATTENUATION: Total, 8 db at 100 cycles

STEPS: 4 steps of 2 db each: 5th step provides 6 db more loss at 30 cps

ROTATION: Clockwise for increased attenuation

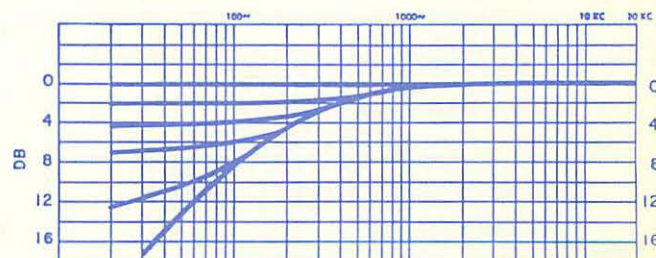

UNIT TYPE VARIABLE EQUALIZERS

MODEL EQ-262 5000 CYCLE VARIABLE EQUALIZER

USE: To correct losses in the 5000 cycle range, to improve tonal balance, increase sibilance and to provide "presence".

INPUT LEVEL: Maximum: +24 dbm; Minimum: -60 dbm

INSERTION LOSS: 8 db

EQUALIZATION: Maximum of 8 db at 5000 cps

STEPS: 8 steps of 1 db each at 5000 cps

ROTATION: Clockwise for increasing equalization

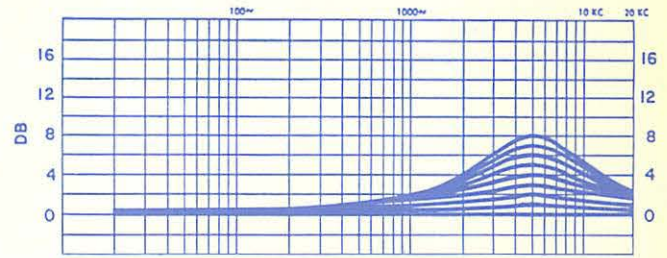

MODEL EQ-263 HIGH FREQUENCY VARIABLE EQUALIZER

USE: For reducing high frequency resonances, to correct excessive sibilance (de-essing) and attenuation of high frequency distortion due to overloading.

INPUT LEVEL: Maximum: +24 dbm; Minimum: -56 dbm

INSERTION LOSS: Zero

ATTENUATION: Total 14 db at 10 keps

STEPS: 7 steps of 2 db each at 10 keps

ROTATION: Clockwise for increasing attenuation

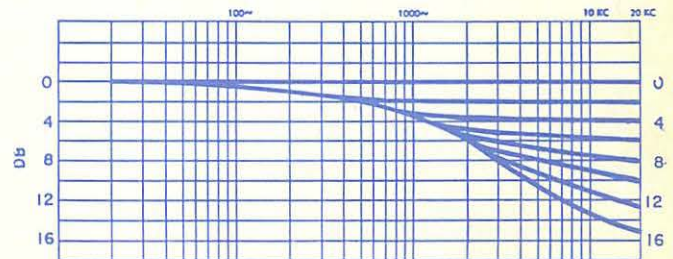

MODEL EQ-265 LOW FREQUENCY VARIABLE EQUALIZER

USE: To provide additional low frequency response, extend the range of equipment in the low frequencies and to equalize tonal balance of "thin" program material.

INPUT LEVEL: Maximum: +24 dbm; Minimum: -56 dbm

INSERTION LOSS: 14 db

EQUALIZATION: Maximum of 12 db at 100 cycles

STEPS: 6 steps of 2 db each at 100 cycles

ROTATION: Clockwise for increased equalization

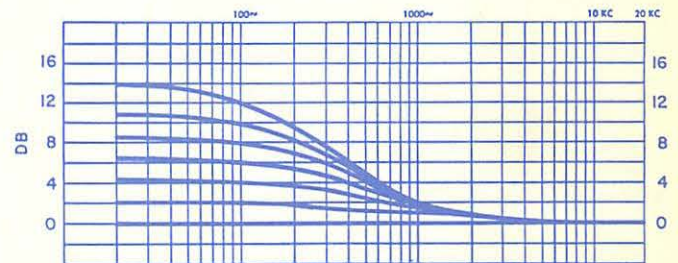

MODEL EQ-266 HIGH FREQUENCY VARIABLE EQUALIZER

USE: To provide additional high frequency response, to compensate manually for disc recorder losses due to smaller recording groove diameter.

INPUT LEVEL: Maximum: +24 dbm; Minimum: -56 dbm

INSERTION LOSS: 14 db

EQUALIZATION: Maximum of 12 db at 10 keps

STEPS: 6 steps of 2 db each

ROTATION: Clockwise for increasing equalization

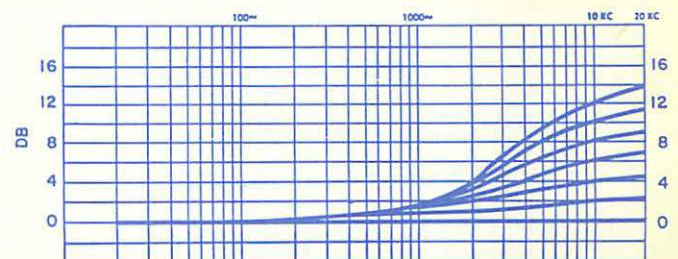

Equalizing for Spectral Character

MODEL EQ-251-A PROGRAM EQUALIZER

- New Concept Gives Variable Equalization at 6 Important Points.
- Only 1½ Inches Wide — 10 units require panel space of 3½ inches high by 15 inches wide.
- Flexible — 2 rotating cam switches for high and low peak settings.
- No tubes or power required — all passive circuits.
- Low Insertion loss of only 14 db.
- Uses etched circuits of military quality for super-compactness.
- Toroid coils — no hum.

GENERAL

The Model EQ-251A Equalizer is Langevin's miniaturization of an instrument that has long been standard for corrective equalization in recording and reproduction of sound. The diminutive size of this precision instrument permits mounting adjacent to mixer controls, thereby making possible multiple installations of several units in close proximity.

The Model EQ-251-A Equalizer's improved design features two sliding levers for equalization and attenuation. The perpendicular sliding action is more functional than rotary action, and facilitates reading of knob positions. Adjustable in 2 db steps at specified frequencies, with a range of 12 db maximum equalization to 16 db maximum attenuation, this instrument is an ideal tool for dubbing and frequency response corrections.

This assembly is a passive, L/C/R, bridged T network, and does not require power supply, tubes or additional connections. It can be inserted directly into a transmission line with only input and output connections.

Two rotating cam switches are provided on the face panel. The switch at the right gives high frequency equalization peaks at 3 kc, 5 kc, 10 kc or 15 kc. The left switch provides low frequency equalization peak settings of 40 cps or 100 cps.

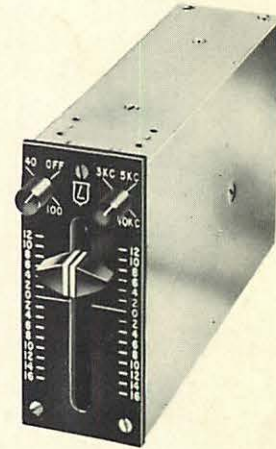

TECHNICAL SPECIFICATIONS

Circuit, Bridge T; **Impedance**, 600/600 ohms; **Insertion Loss**, 14 db; **Input Level**, minimum: -70 dbm, maximum: +20 dbm; **Phase Shift**, negligible; **Power Requirements**, none; **Terminals**, plug-in; **Finish**, black non-halation, satin finish, anodized aluminum with engraved markings. Chassis parts are nickel plate on brass. **Dimensions**, panel: 1½ inches wide by 3½ inches high; 5½ inch depth behind mounting panel.

ORDERING INFORMATION

MODEL EQ-251-A PROGRAM EQUALIZER, complete with female plug receptacle, mounting hardware and instructions; **Weight**, Net, 1¾ lbs., shipping 3 lbs.

Model EQ-258-A Equalizer

Has the same specifications as the EQ-251-A but designed for rack mounting. Size is 3½ in. h by 19 in. w by 5¼ in. d. Finish is Langevin light gray. Complete with instructions. **Weight**, Net, 4½ lbs, 6 lbs shipping.

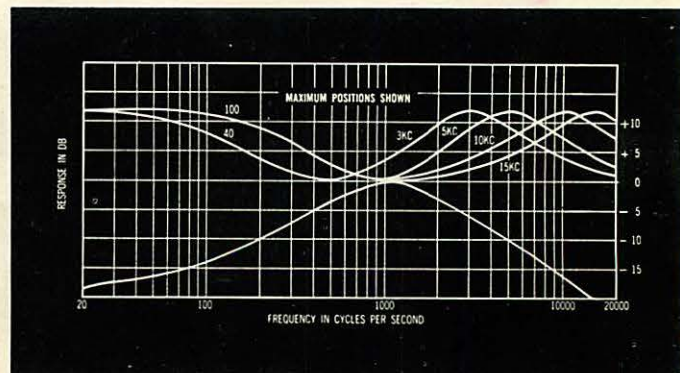
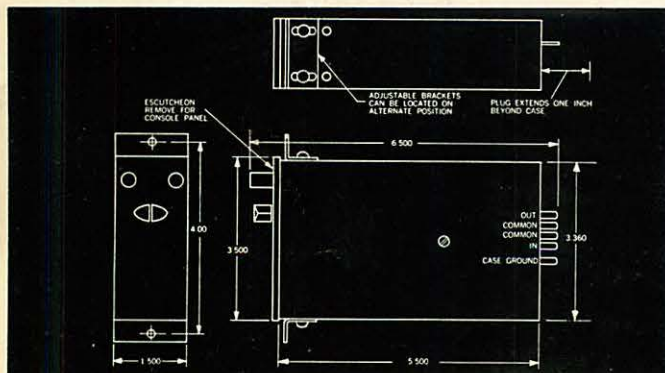

MODEL EQ-252-A GRAPHIC EQUALIZER

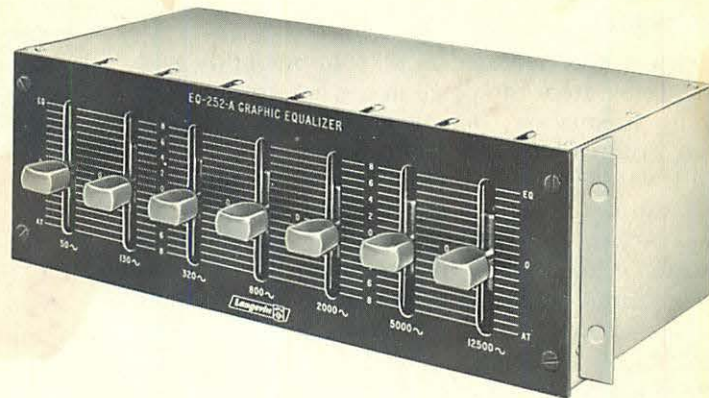

Model EQ-252-A

7 POSITIONS FOR ULTIMATE CONTROL OF SPECTRAL QUALITY IN RECORDING, TV-BROADCAST AND MOTION PICTURES

FEATURES

- 7 Selected Positions of Variable Hi-Lo Equalization and Attenuation.
- Gold plated, Noise-free, Switching through ± 8 db in 1 db steps during active use.
- Hum-free performance through toroid coils from -70 to $+24$ dbm.
- No tubes or power required—all passive Bridge T circuits in one integrated unit.
- Small size: $3\frac{1}{2}'' \times 10\frac{1}{2}'' \times 5\frac{3}{4}''$ deep.

GENERAL

The Langevin Model EQ-252-A Graphic Equalizer fulfills the critical need for multiple control at the subjectively important points of the audio range. It employs miniaturized, military quality, gold plated, etched circuitry in each of the 7 plug-in filter units, resulting in a passive assembly requiring no tubes or power supplies. Only input and output connections are required. Sliding Levers permit 8 db of equalization and 8 db of attenuation in 1 db steps at 50, 130, 320, 800, 2000, 5000 and 12,500 cps during the program through noise-free gold-plated switching. Modern controls give quiet operation at -70 up to $+24$ dbm.

Filter assemblies use sealed toroid coils for hum-free operation. Careful design delivers $\pm \frac{1}{2}$ db accuracy. Overlap from one filter to the next gives combined flat output when levers are in a straight line in any equalized or attenuated position (see curves). Special frequencies are available to order; overlap may or may not provide combined flat output between adjacent positions as the standard frequencies shown have been calculated for this effect. In zero position each or all filters are flat (resistive only, 16 db loss) from input to output. Because all passive circuitry is used there is no distortion when operated up to plus 24 dbm. Impedance is 600 ohms in and out; for other impedances use Langevin line to line transformers, Model TF-602-C. The model EQ-252-A is limited to 600 ohms impedance for the reason that lower impedances would double the size of the equalizer components every time the impedance is halved.

SPECIFICATIONS

Circuit: Bridged T; Impedance: 600/600 ohms; Insertion Loss: 16 db; Operating Level: -70 to $+24$ dbm; Positions: 7, with 8 db of equalization and 8 db of attenuation at 50, 130, 320, 800, 2000, 5000 and 12,500 cps in 1 db steps; Distortion: none; Coils: Sealed toroids; Power Requirements: none; Response: See curves; Panel Finish: Black, satin finish, non-halation, anodized aluminum; Terminals: solder type, turret; Filter Sections: 7 plug-in, printed circuit type; Size: $3\frac{1}{2}''$ high by $10\frac{1}{2}''$ long by $5\frac{3}{4}''$ deep overall.

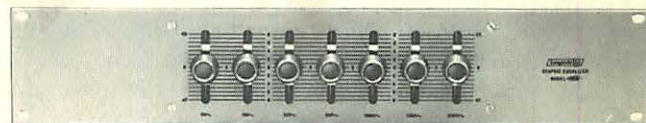

Model EQ-270-A

ORDERING INFORMATION

Model EQ-252-A Graphic Equalizer equipped with red knobs, complete with mounting hardware and instructions. Weight, net 9 lbs.; 14 lbs. shipping.

Model EQ-270-A Graphic Equalizer

Has the same specifications as the EQ-252-A but designed for rack mounting. Size is $3\frac{1}{2}$ ins. h by 19 ins. w by $5\frac{3}{4}$ ins. d. Finish is Langevin light gray. Comes complete with instructions. Weight, Net, 12 lbs; shipping 14 lbs.

Recommended Accessories

When lower impedances than 600 ohms are required, use the following matching coils in and out:

Model TF-602-C Line to Line Transformer, Weight, Net, $2\frac{3}{4}$ lbs.; $3\frac{1}{2}$ lbs. shipping.

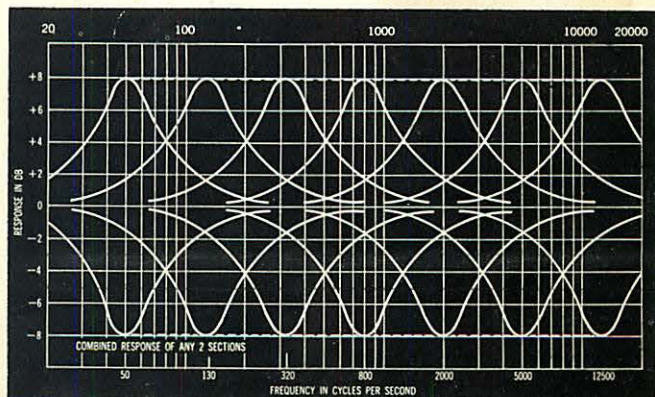

INTRODUCTION

A mixer is a device used to *increase* smoothly with unrecognizable steps the signal in the line from a point of infinite attenuation. This is called "fading-in" the program material. Secondly, the function of a mixer control is to raise and lower the level of the program material during a performance over a range within the dynamic, or the working limits, of the associated equipment. Thus, either the maximum, or a lower desired dynamic range can be maintained without overloads, without signal reduction into the noise threshold of the equipment, and without recognizable frequency discrimination during the process.

A variable attenuator is defined here as a resistive device used in audio transmission circuits to reduce level uniformly at all frequencies flowing through the interconnecting line. Philosophically, then, a mixer control is a specialized type of attenuator.

Attenuators used in some measuring equipment, for instance, reduce the signal a certain number of db and sometimes cut off to infinite attenuation on the last step. This abrupt transition makes it unsuitable for use as a mixer, all other things being equal. A mixer is designed so that the last few steps attenuate to infinity rapidly but without abrupt or noticeable transitions during the last few degrees of travel.

HOW MANY STEPS SHOULD YOU CHOOSE

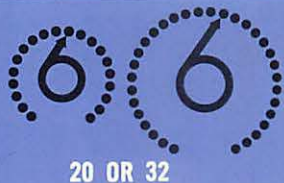

HERE IS THE DIFFERENCE

This leads us to the heart of the problem in selecting a good mixer: smooth transition from one degree of attenuation to another. The greater the number of steps, the smoother and less noticeable is the mixing operation in the sound output.

A comparison of signal levels only 1 db apart requires close study by AB comparison to detect a level change. A change of 1½ db is perceptible by study, but under program operating conditions cannot be discerned. Thus, 30 steps 1½ db apart determines the number of transitions required for high quality mixing and is standard throughout the industry for rotary mixers.

Smaller, less expensive mixer controls are limited to 20 steps. This allows 2 db of attenuation per step. Sometimes, especially in portable equipment, space is the vital consideration and this limits the choice to units with this number of steps. Operation can be classed as good.

SLIDE WIRE MIXERS

Smoothest operation is achieved by slide wire mixers, where the transitions from one level to another are only one tenth of a db apart. For this reason they are employed in music scoring and other critical applications where best quality is demanded.

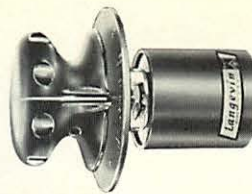

ROTARY TYPES

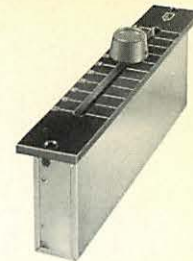

STRAIGHT LINE TYPES

CIRCUIT TYPES for MIXERS AND ATTENUATORS

There are two classes of circuits for mixers and attenuators. These are the *unbalanced* and *balanced* types.

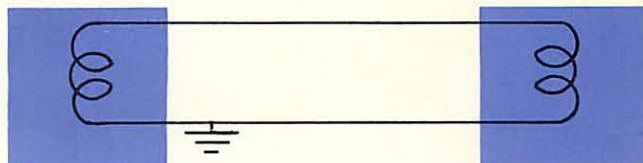

UNBALANCED CIRCUITS

In unbalanced circuits one side of the line must be grounded. In a mixer control the position in the equipment circuit is usually predetermined, allowing unbalanced operation where provision is made to insure against induced hum resulting from a ground loop. In the case of attenuators, their use in gain sets and balanced lines invokes a determination as to whether a ground on one side will short out parts of the circuit or cause an undesirable ground loop.

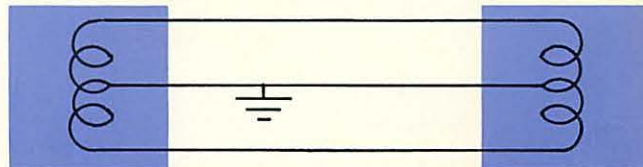

BALANCED CIRCUITS

Symmetrical components with the central part of the configuration going to ground characterize a balanced circuit. This circuit is not susceptible to hum from loops due to misplaced grounds. In addition the balanced characteristic eliminates the shorting out of circuit components if the ground is used and if it is centrally located with respect to each side of the line.

STEREO'S MOST MODERN MIXER

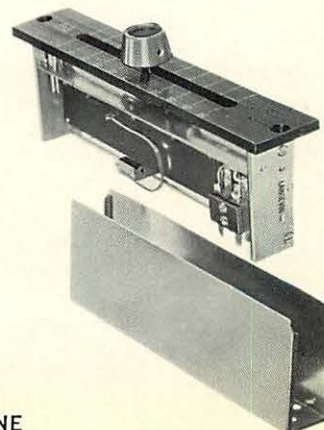

SLIDE-WIRE LADDER STRAIGHT LINE

CHOOSING THE MIXER FOR CIRCUIT, FORM AND TYPE

While Langevin supplies all classes, forms and circuit types in mixer controls, it would be remiss in its obligation to the user if it did not make recommendations and cite advantages and disadvantages in the use of the various kinds available. Accordingly we will treat on these recommendations in three sections: the choice of circuit for mixing, submastering and mastering; the choice of attenuator form, that is, rotary or straight-line, and the choice of step type versus continuous slide wire.

THE MIXER CIRCUIT LOW OR HIGH LEVEL MIXING

Mixing in low-level circuits before preamplification saves on the number of preamplifiers, as the inputs can be combined in varied proportions through the mixers and then fed to a single preamplifier. Referring to the illustrations succeeding, it will be seen that beyond a certain number of inputs the paralleling losses cannot be overcome by the amplifier with Ladder networks, whereas "T" networks, with lower insertion loss, allow a greater number. Thus, the designer's judgement enters the picture, considering at the same time the higher susceptibility to contact noise because of amplification *after* the mixing operation and other system noise. Thus, low-level mixing is distinctly a compromise, and finds favor usually in cases of portable, light weight mixer designs whose application is not critical in final output quality. The cost of "T" networks is higher than that of ladders.

LADDER VERSUS "T" CIRCUITS

The ladder circuit allows virtually an infinite cut-off to about -120 db; the "T" circuit extends down to the order of only -100 db. But the "T" circuit still has proponents who point out, for example, that in the last six positions of a 600 ohm ladder 30 step mixer there is a 30% drop in impedance at the output of the mixer to about 400 ohms. The argument holds that mixers are employed in multiple, and that the slight mismatch, as shown by the illustration, will preclude virtually any measurable discrimination due to mismatch.

Here, then, is a listing of the points in favor of the ladder circuit for mixers:

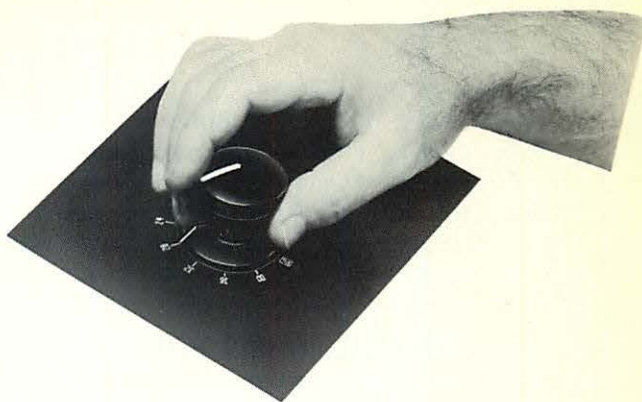

1. As attenuation takes place, contact noise decreases in proportion. This is the converse of "T" circuits, where the contact noise remains the same in any position.
2. Mismatch effects, however theoretical, decrease in direct proportion to the number of units that are paralleled into the next circuit, so that with 3 or 4 units or more operating in a bank of ladder mixers, impedance mismatch practically vanishes.
3. In the smaller units, size, too, must be taken into account, for the added parts of the "T" circuit require more space.
4. The last consideration, if not the most important one, is cost, for double the circuitry and moving parts are necessary for "T" configurations.

"T" AND BALANCED "H" ATTENUATORS

After a group of mixers have been paralleled it is standard practice to add further amplification in the form of a booster amplifier to offset the paralleling or matching losses occasioned by the restoring of the 600 ohm circuit impedance. After the booster amplifier, a submaster or master control is employed to feed this group on to other circuits containing equalizers, limiters, or perhaps the bridging bus. Because the latter parts of the circuit sometimes are located in racks distant from the mixer section, balanced lines may be desirable to provide insurance against hum from ground loops as well as for other circuit reasons. In these cases the submasters and masters may be balanced as well. Because we are dealing with one circuit after all combining has taken place and now have higher levels, possible contact noise from "T" and "H" attenuators presents less hazard. In addition, these controls are usually preset, and accordingly may be provided with detents to facilitate changes in precise increments as well as return to marked positions. Moreover, after preamplification and subsequent matching and equalizing, it is desirable to introduce as few other losses into the circuit as possible, and the zero loss feature of the "T" and "H" circuits becomes helpful.

"T", "H", and "L" circuits also find use in measuring equipment, and Langevin lists these further on without taper, as well as with tapered cut-offs, with and without detents. All mixers are also available with cue circuits.

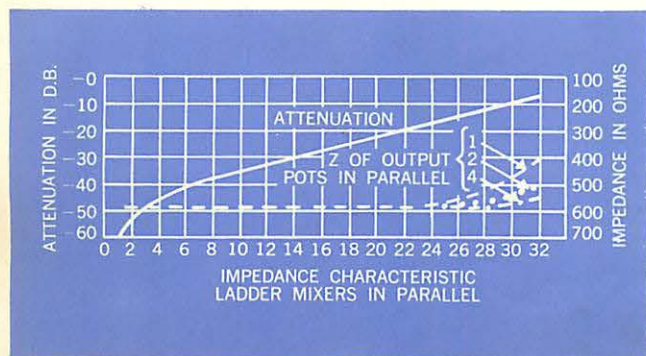

There are a number of different circuits which may be used to combine mixer outputs to form a composite program channel. Several types are illustrated with the advantage and disadvantages listed for each. While it is not the policy of Langevin to dictate design, it is felt that the making of recommendations is a duty of the equipment manufacturer.

HIGH LEVEL PARALLEL LADDER MIXER

The most highly recommended circuit for combining mixer outputs is shown below. This circuit is used to combine equal impedances to form a single program channel with a master gain control of the same impedance. Any number of circuits may be combined in this way by selecting the proper fixed network as shown on another page in this catalog. In the illustration 4 circuits are shown which would result in a loss of 24 db if a ladder master control is used.

Note that the attenuator cases are shown grounded. But signal grounds (common) are taken on individual wires to a single point ground.

The phase relationships of all inputs are the same, and this configuration may be duplicated for additional stereophonic channels as required.

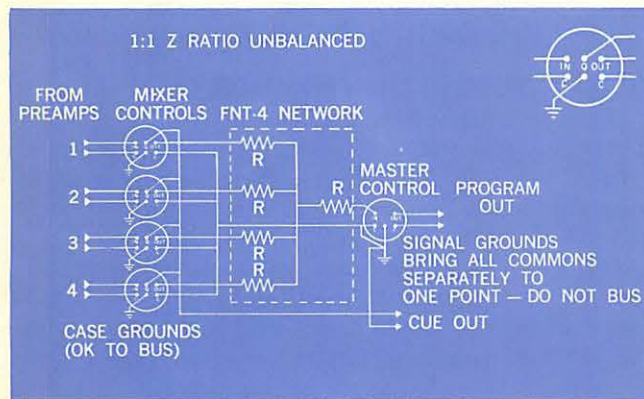

TOTAL CHANNELS COMBINED	LOSS IN DB DUE TO PARALLELING		TOTAL LOSS IN DB IF MASTER IS USED	
	"T"	LADDER	"T" OR "H"	LADDER
2	6	12	NO ADDED LOSS	18
3	9.5	15.5		21.5
4	12	18		24
5	14	20		26
6	15.6	21.6		27.6
7	16.9	22.9		28.9
8	18.1	24.1		30.1
9	19.1	25.1		31.1
10	20	26		32
11	20.8	26.8		32.8
12	21.6	27.6		33.6
13	22.3	28.3		34.3
14	22.9	28.9		34.9
15	23.5	29.5		35.5
16	24.1	30.1		36.1

PARALLEL LADDER MIXER WITH MINIMUM LOSS NETWORK

This is a special application of the mixer circuit shown above. It is used where more mixer circuits may have been added or losses otherwise have been incurred, and more gain would be advantageous to offset these losses. It is only applicable where an unloaded input is available in the booster stage. It should be noted that the series output resistor has been eliminated. The master gain control must be used after the booster amplifier.

All phase relationships are maintained and the circuit may be duplicated for additional stereo channels.

The advantage of this circuit is displayed when a large number of mixer attenuators must be combined. In all cases this will produce a loss of 6 db less than the conventional mixer network first treated on.

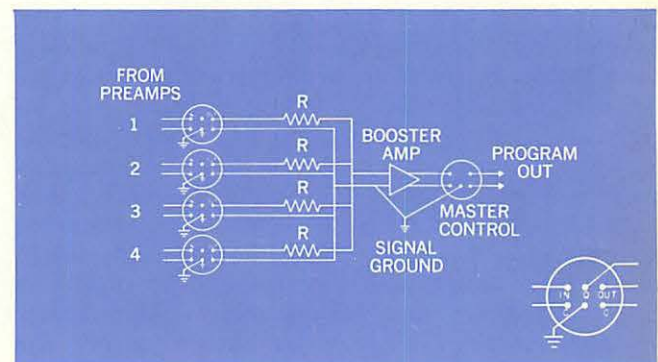

HIGH LEVEL SERIES MIXER CIRCUIT

Mixers in series with a balanced master gain control have been used in some applications, such as in lower cost, lighter weight portable units. Where quality is not paramount, low level mixing may be employed, saving on the number of preamplifiers. 3 db less loss is typical of this configuration. The disadvantage of this circuit is the presence of unequal impedances, the phasing is not maintained in all circuits, and the master must be a balanced control. This circuit is *not* recommended for stereo applications because of multiple microphone phasing problems, but can be used, probably with complete satisfaction, for monophonic radio remotes.

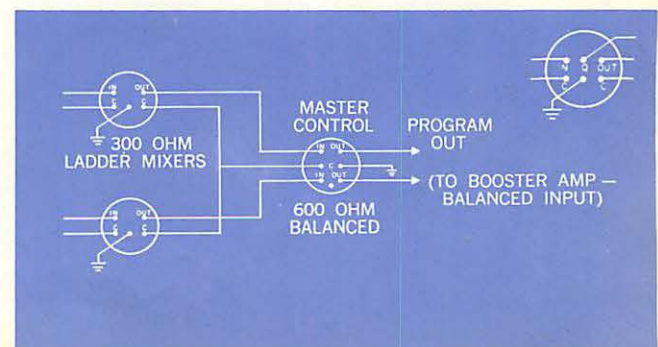

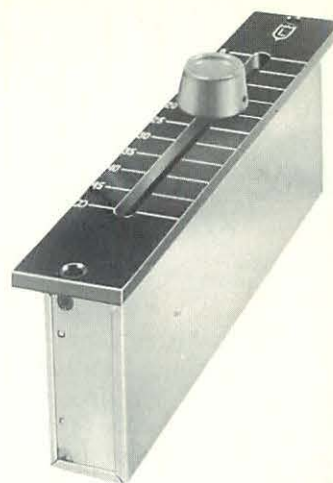
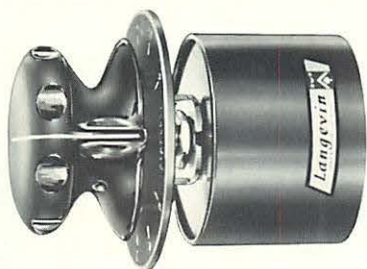

MIXER FORM

SHOULD YOU CHOOSE STRAIGHT LINE OR ROTARY MIXERS?

The advent of stereo recording has vastly increased the complexity of control consoles. Precise regulation of individual sections of the orchestra and soloists in monaural recording has called for the use of a multiplicity of mixer controls. The use of a complex of mixers has been virtually trebled by the demands of 3 channel stereo.

An expansion of the console in the horizontal plane has been called for. But a recording engineer has arms only so long, so that when we consider practicalities, the following calculations should enter into the choice of mixer control form:

Rotary mixers have a diameter usually of 2 to 3 inches; dial and knob or panel engravings are on approximately 6" centers. It can be seen that horizontal console dimensions can become inordinately large. On the other hand, Langevin Straight Line Mixers present an ideal solution to the problem in a number of ways.

These narrow vertical mixers require only 1½ inches between mounting centers (1¼" on order with narrower escutcheon), permitting a full complement of control for 3 channels, all within easy reach. Moreover, at least two mixer controls can be operated with one hand; many recordists operate three, and for some effects, as many as four.

There are other advantages to the Langevin Straight Line units. Full recognition of the mixer level setting is apparent from the vertical position of the knob, giving better indication of position than a round knob affords. Operation is smoother than with rotary mixers, as only two grams of static friction need be overcome to change position of the control. While it is true that rotary mixer knobs allow "rolling" with the side of the palm for effects, the vertical mixer exceeds in flexibility because the knob can actually be "snapped", as well as faded rapidly. This can be done with only one finger if necessary.

CHOICE OF MIXER TYPE

It is true that convention and habit enter into the choice of mixer form, so Langevin makes all types. Remember that smoothest mixing is delivered by straight line slide wire mixers because of the small .1 db increments. But the use of straight line mixers calls for the development of new skills by the recording engineer; as long as fifteen years ago the motion picture studios employed vertical mixers on 20 channel re-recording consoles for best quality and as the sole solution to human requirements. Stereo has intensified operations to the end that Langevin Straight Line Mixers present a practical manner of achieving high quality and complete stereo control within physiological limits.

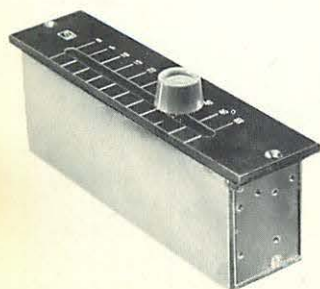

MX-111-2
2-GANG MIXER



MX-111-3
3-GANG MIXER

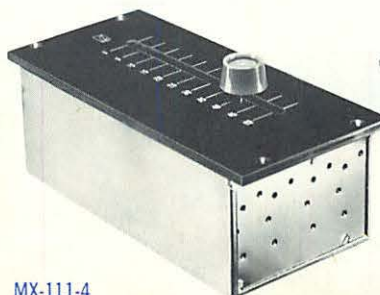

MX-111-4
4-GANG MIXER

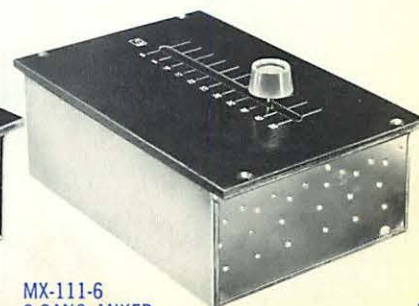

MX-111-6
6-GANG MIXER

MODEL MX-111 STRAIGHT LINE MIXER CONTROL

"Between the Artist and the finest recording"

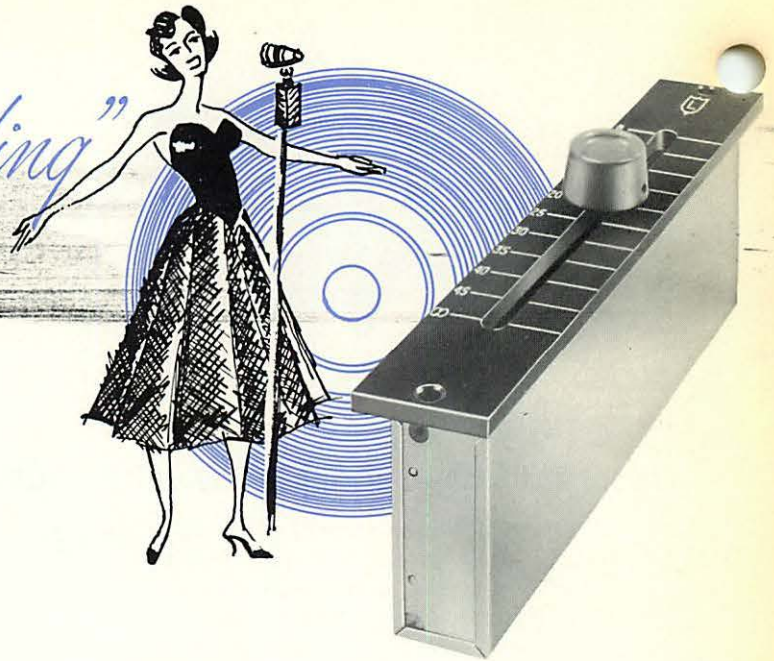

These Straight Line Mixer Controls are highly developed units using resistances in a ladder configuration to afford unusual facility in operation on consoles. They are used to blend signals of various origin for music scoring, re-recording, high quality public address, radio and TV broadcasting. Only 1½" of horizontal panel space is required (1¼" with alternate escutcheon) and they are 6½" long. This series is the most compact of the type available, and extends only 2¼" below the top of the mounting surface. Several units can be operated with one hand when mounted adjacent.

FEATURES

1. SMOOTH, SILKY OPERATION FOR EASY CONTROL

Most important to the operator is the overcoming of friction in the mixer control. In these precision-built mixers, a nylon bearing rides along a longitudinally honed, hardened chrome-plated shaft. Smooth operation is the result of the exceedingly low coefficient of friction; only 2 grams of pressure is required to overcome the inertia and bearing friction of the control assembly.

2. LOW CONTACT NOISE FOR CLEAN, CLEAR SIGNAL

A single contact brush fabricated of the same material as the resistance wire prevents generation of thermal voltages, contact oxidation and consequent noise. This brush is connected to the input circuit by a beryllium copper spring strip, eliminating the need for additional noise inducing brushes.

3. EXCLUSIVE DIRT AND LINT BARRICADE FOR TROUBLE-FREE PERFORMANCE

An accessible lint and dirt trap over the resistor element eliminates the cleaning nuisance formerly as-

sociated with this form of control.

4. PLUG-IN DESIGN FOR EASY MAINTENANCE

Connections are made by an integral plug to the connecting cable socket. This permits rapid disassembly for inspection and cleaning.

IMPORTANT NOTICE

ALL SLIDE WIRE MIXERS REQUIRE PERIODIC CLEANING.

5. FRICTION ADJUSTING SCREW FOR ANGLE OR VERTICAL MOUNTING

For those recording engineers who desire less freedom of movement in the control, or for the designers who wish to incorporate a steep or vertical slope to the control panel, a friction adjusting screw on the guide shaft is accessible through the front slot on the control in which the knob assembly rides.

6. AVAILABLE IN 2, 3, 4 AND 6 GANGS FOR STEREO

For stereophonic controls these mixers are available in 2, 3, 4, and 6 gang assemblies operating from a single knob. This vastly simplifies console controls.

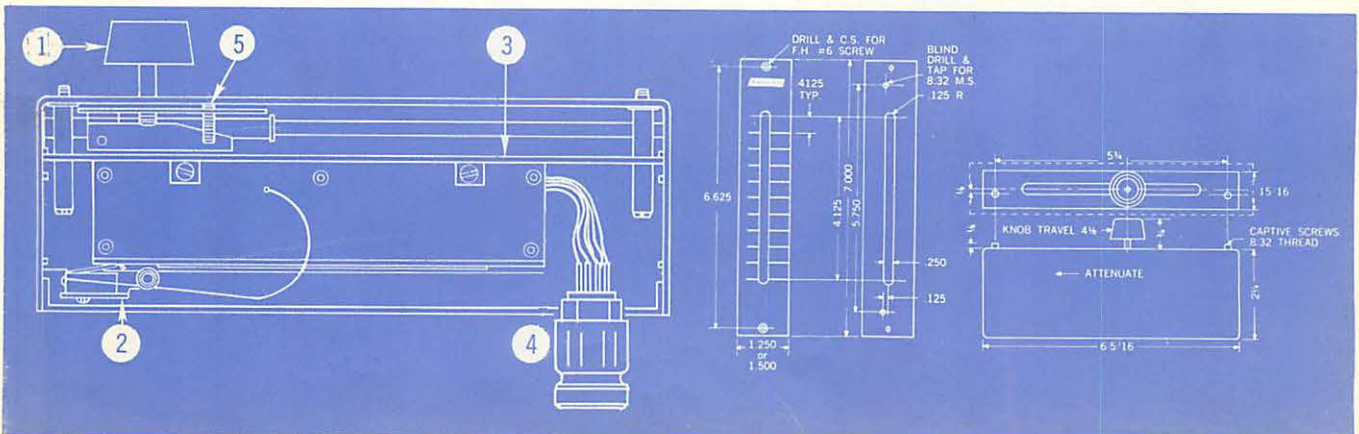

SPECIFICATIONS

STRAIGHT LINE MIXER ATTENUATORS STEP AND SLIDE WIRE

DIMENSIONS: ALL ARE 6¼ L x 2¼ DEEP; WIDTH: SINGLE 1¼; 2 GANG 1½; 3 GANG 2½; 4 GANG 3¾; 6 GANG 4½
RESISTOR ACCURACY 5%

LANGVIN MODEL	CIRCUIT	STEPS	DB PER STEP	2 GANG MODEL	3 GANG MODEL	4 GANG MODEL	6 GANG MODEL
MX-100	Unbal. Ladder	20	2	MX-100/2	MX-100/3	MX-100/4	MX-100/6
MX-102	Unbal. Ladder	30	2	MX-102/2	MX-102/3	MX-102/4	MX-102/6
MX-113	Unbal. Ladder	32	1½	MX-113/2	MX-113/3	MX-113/4	MX-113/6
MX-111	Unbal. Ladder	Slide Wire		MX-111/2	MX-111/3	MX-111/4	MX-111/6
MX-101	Bal. Ladder	20	2	MX-101/2	MX-101/3	MX-101/4	MX-101/6
MX-103	Bal. Ladder	30	2	MX-103/2	MX-103/3	MX-103/4	MX-103/6
MX-104	Bal. Ladder	32	1½	MX-104/2	MX-104/3	MX-104/4	MX-104/6
MX-106	Bridge T	20	2	MX-106/2	MX-106/3	MX-106/4	MX-106/6
MX-107	Bridge T	30	2	MX-107/2	MX-107/3	MX-107/4	MX-107/6
MX-114	Bridge T	32	1½	MX-114/2	MX-114/3	MX-114/4	MX-114/6
MX-115	Potentiometer	20	2	MX-115/2	MX-115/3	MX-115/4	MX-115/6
MX-117	Potentiometer	30	2	MX-117/2	MX-117/3	MX-117/4	MX-117/6
MX-120	Potentiometer	32	1½	MX-120/2	MX-120/3	MX-120/4	MX-120/6
MX-124	Potentiometer	Slide Wire		MX-124/2	MX-124/3	MX-124/4	MX-124/6
MX-112	Dual Pot	20	2	MX-112/2	MX-112/3	MX-112/4	MX-112/6
MX-118	Dual Pot	30	2	MX-118/2	MX-118/3	MX-118/4	MX-118/6
MX-121	Dual Pot	32	1½	MX-121/2	MX-121/3	MX-121/4	MX-121/6

ORDERING INFORMATION

MXD — Detented condition for standard straight line mixer step attenuator (not available on slide-wire models).

MXP — Precision steps (not available on slide-wire models). Detents are standard.

MXQ — Cue positions for all straight line attenuators.

For example a "MX100/G" is a unbalanced ladder, 20 step, 2 db per step, 600/600 ohm.

Example #2; "MXDQ100/2G" is the same specification except, with detent, cue position and two gang.

Example #3; "MXPQ100/2G" is the same specification except with precision attenuation steps.

Note: 1. For impedance definition, see impedance code chart on page 60.

2. Number of steps or decibel steps other than those shown are available.

STRAIGHT LINE STEP ATTENUATORS & GRID POTENTIOMETERS

DIMENSIONS: ALL ARE 6¼ L x 2¼ DEEP; WIDTH: SINGLE 1¼; 2 GANG 1½; 3 GANG 2½; 4 GANG 3¾; 6 GANG 4½ RESISTOR ACCURACY 1%

LANGVIN MODEL	CIRCUIT	STEPS	DB PER STEP	2 GANG MODEL	3 GANG MODEL	4 GANG MODEL	6 GANG MODEL
AT-700	Unbal. Ladder	20	2	AT-700/2	AT-700/3	AT-700/4	AT-700/6
AT-702	Unbal. Ladder	30	2	AT-702/2	AT-702/3	AT-702/4	AT-702/6
AT-701	Bal. Ladder	20	2	AT-701/2	AT-701/3	AT-701/4	AT-701/6
AT-703	Bal. Ladder	30	2	AT-703/2	AT-703/3	AT-703/4	AT-703/6
AT-704	Bridge T	20	2	AT-704/2	AT-704/3	AT-704/4	AT-704/6
AT-705	Bridge T	30	2	AT-705/2	AT-705/3	AT-705/4	AT-705/6
AT-706	Balanced H	20	2	AT-706/2	AT-706/3	AT-706/4	AT-706/6
AT-707	Balanced H	30	2	AT-707/2	AT-707/3	AT-707/4	AT-707/6
GC-400	Potentiometer	20	2	GC-400/2	GC-400/3	GC-400/4	GC-400/6
GC-404	Potentiometer	30	2	GC-404/2	GC-404/3	GC-404/4	GC-404/6
GC-402	Dual Pot	20	2	GC-402/2	GC-402/3	GC-402/4	GC-402/6
GC-406	Dual Pot	30	2	GC-406/2	GC-406/3	GC-406/4	GC-406/6

ORDERING INFORMATION

ATV — Denotes last step infinity for unbalanced ladder, balanced ladder, bridge T and balanced H.

ATQ — Cue position.

GCV — Denotes last step infinity for potentiometer and dual potentiometers.

GCQ — Cue position.

For example, a AT700G is a unbalanced ladder, 20 step, 2 db per step, 600/600 ohm.

Example #2: ATVQ700/2G is the same specification except last step infinity and two gang.

Example #3: GCVQ400/2M is a potentiometer, 20 step, 2 db per step, last step infinity, cue position, two gang, 10K ohm.

Note: 1. For impedance definition, see impedance code chart on page 60.

2. Number of steps or decibel steps other than those shown are available.

ESCUTCHEONS

Suffix

Dimensions

ES	1½" wide x 7" long x ¾" thick (single)
EW	1½" wide x 7" long x ¾" thick (single)
E2	1½" wide x 7" long x ¾" thick (two gang)
E3	2¾" wide x 7" long x ¾" thick (three gang)
E4	3¼" wide x 7" long x ¾" thick (four gang)
E6	4¾" wide x 7" long x ¾" thick (six gang)

Examples: MX100EW, MXD100ES, MXP100E2, MXQ100E3.
AT700EW, ATV700ES, ATQ700E2, GCVQ400E3.

STEREO PAN POTS

FOR POSITIONING THE SOURCE BY INTENSITY CONTROL

GENERAL INFORMATION

As early as 1934 it was well established that a level change of 3 db was sufficient to displace the apparent source of an instrument or vocalist completely across the recorded field. Langevin engineers developed the first controls for this application, known as "Pan Pots".

While it is known also that arrival time of the sound influences the position of the apparent source, it has been proven that intensity can offset the effects of arrival time satisfactorily. In motion picture work at least two screen processes, Vistavision and Perspectasound, clearly demonstrate the complete success of Pan Pots in achieving control over position.

The configurations of these mixer control assemblies are different from those usually encountered in regular transmission work. In two-channel systems two oppositely wound controls are ganged so that the 3 db down point of each control occurs at zero degrees. For 3 channel systems three controls are ganged, and the windings of each so constituted that the 3 db down points occur 45 degrees each side of zero degrees or center. At either 90 degree position the extreme opposite channel is at infinite attenuation. While it is possible to make arrays which traverse an angular field up to 360 degrees, only 180 degree fields are listed here. Special Pan Pots for unusual applications are available on order from Langevin.

Pan Pots are available in both the rotary type and straight line type.

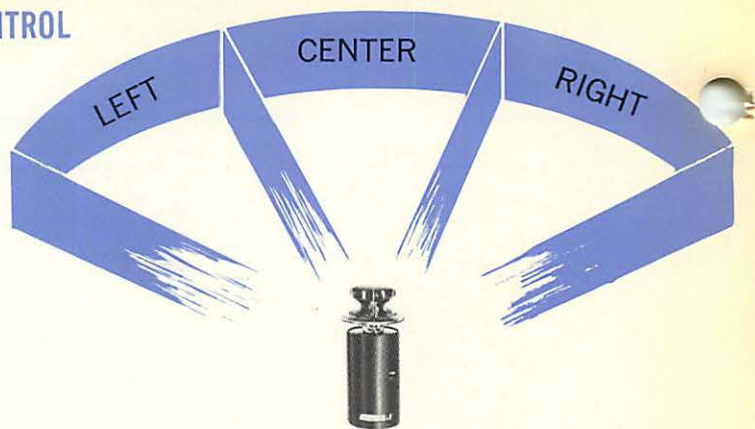

APPLICATIONS RECORDING FOR PROPER GEOMETRY

Pan Pots can be employed to change the position of one section of the recording field to another. Either the 2 gang or 3 gang Pan Pots can also be used to pick up a monaural source, and place this monaural source in any geometrical position in the final stereo recording.

DESCRIPTION

Pan Pots do not adapt themselves to slide wire arrays for reasons of space. Moreover, the unusual taper of each winding demands only 16 positions in each for smoothest transition throughout the audible range of control; it will be discerned by study of the figures that attenuation at the extremes is unusually rapid, and that it is very slow in the regions of overlap from one section to another. The rate of attenuation is precise, and conforms to the exact calculations governing angular displacement in the sound field with change in level.

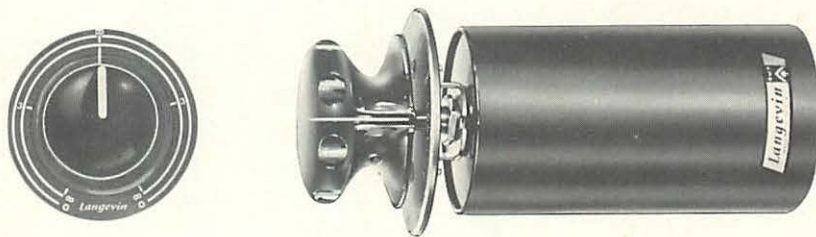

ORDERING INFORMATION

MODEL RPP-2 ROTARY PAN POT, for mixing 1 channel into 2. 600 ohms impedance in and out. Ladder type, insertion loss 12 db. 270° rotation with -3 db point at 0°, 90° at extreme right and left. 16 steps used per section with special geometrically accurate taper. Includes RCA type K-108 knob and model D-111 dial plate.

MODEL D-111 DIAL FOR ABOVE, engraved black satin anodized aluminum, with standard color code for geometry, recordist left blue, right red. Size, 2 3/4" diameter by 3/32" thick.

MODEL K-108 KNOB, RCA Type, glossy black bakelite normally supplied, but available also in R, Red, OR, Orange, W, White, BL, Blue, G, Green, P, Purple, GR, Gray, and Y, Yellow. Please specify. Size, 2 3/8" diameter by 1 1/2" high.

MODEL SLPP-2 STRAIGHT LINE PAN POT, 1 channel into 2, same as Model RPP-2 above but straight line form, for horizontal panel placement. Supplied with type K-1050 red knob. Size is 15/16" wide by 6 1/4" long by 2 1/4" deep behind mounting plane. Extends 3 1/4" to top of knob. Does not include escutcheon. Weight, net 6 1/2 oz, 1 lb shpg.

MODEL SLPP-2E ESCUTCHEON FOR ABOVE, 3/16" dural black satin anodized engraved. Recordist left track

ROTARY AND STRAIGHT LINE TYPES

is colored blue and right track red. -3 db point is at 0° center with infinite attenuation at 90° each side.

Size is 1½" wide by 7" long by 3/16" thick.

MODEL RPP-3 ROTARY PAN POT, for mixing 1 channel into 3. Same as Model RPP-2 but with 3 elements and insertion loss of 12 db; left range tapers from zero attenuation to infinite in center at 0°. Right side of control is opposite on same contact row diameter. Center ganged control is zero attenuation at 0° with infinite attenuation at extreme right and extreme left rotation. Size is 3" diameter and 2⅞" deep. Weight, net 13 oz., 1½ lbs. shpg.

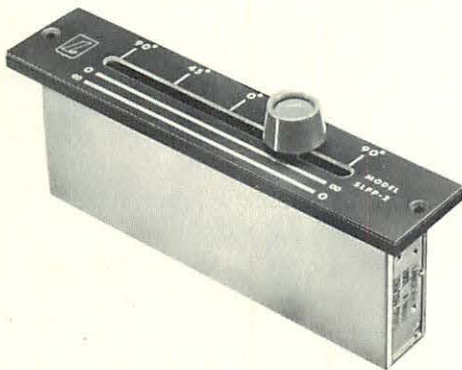

MODEL D-112 DIAL FOR ABOVE, same as D-111 but recordist left channel, blue, is infinite attenuation at 0° center, right channel, red, is opposite and center channel, white, is zero attenuation center and infinite attenuation at extreme right and extreme left. Size is 2¼" diameter by 3/32" thick.

MODEL SLPP-3 STRAIGHT LINE PAN POT, 1 channel into 3, same as Model SLPP-2 but with pots ganged and 12 db insertion loss; includes red knob. Weight, net 13 oz., 1½ lbs. shpg.

MODEL SLPP-3E ESCUTCHEON FOR ABOVE, same as Model SLPP-2E above but recordist left channel, blue, is infinite attenuation at 0° center, right channel, red, is opposite and center channel, white, is zero attenuation center and infinite attenuation at extreme right and extreme left. Size is 1¼" wide by 7" long by 3/16" thick.

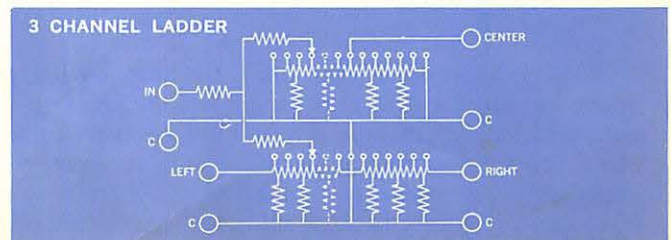
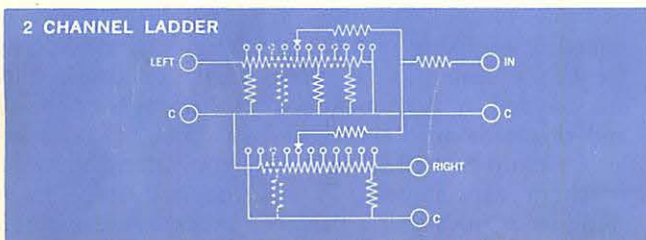
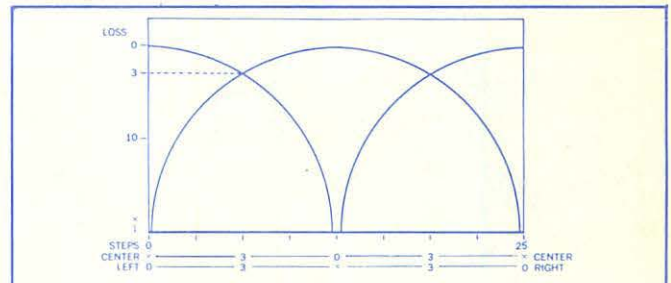
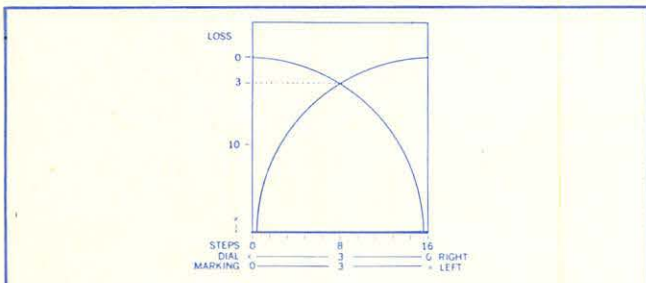
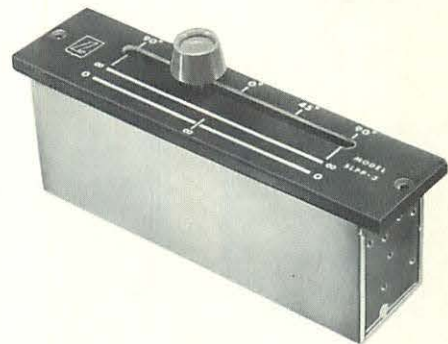

UNBALANCED OR
ASSYMMETRICAL
NETWORKS

BALANCED OR
SYMMETRICAL
NETWORKS

LADDER

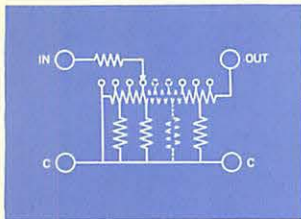

USED FOR MIXER,
SUBMASTER AND MASTER

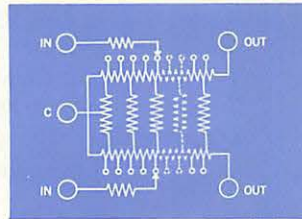

USED FOR MIXER,
SUBMASTER AND MASTER



The ladder attenuator is not only the simplest but the most popular circuit form used in attenuators for transmission networks. It derives greatest usage as a mixer and consists of a series of pi sections which combine, through a control lever, to give the proper terminal impedances with changes in signal level. The insertion loss of these units in various parallel mixer combinations is shown in the table on page 52. As balanced networks, shown in the diagram, the circuit configuration exhibits double the number of components, and allows more freedom in grounding.

"T"

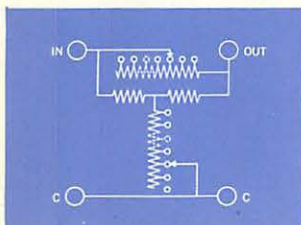

USED FOR MIXER (INFREQUENTLY),
SUBMASTER, MASTER, VU RANGE
EXTENDER AND IN MEASURING
EQUIPMENT

"H"

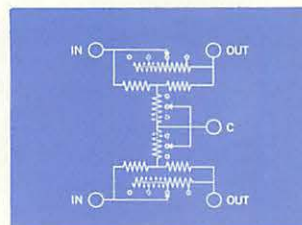

USED AS SUBMASTER,
MASTER AND IN MEASURING
EQUIPMENT

"T" attenuators have features differing from ladder types. For instance, the insertion loss of a "T" network is zero, and in the case of certain mixer configurations for portable equipment afford the advantage of less loss in parallel use. The table on page 52 shows just what this saving amounts to in comparison with ladder units, and the illustrations of typical mixer circuits shown later disclose that some series parallel arrangements allow still lower losses. Proper design of portable equipment coupled with "T" units may save the weight of several low-level amplifiers.

POTENTIOMETERS

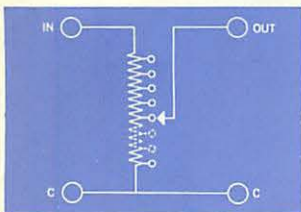

USED FOR HIGH IMPEDANCE
LEVEL CONTROL TO 1 GRID

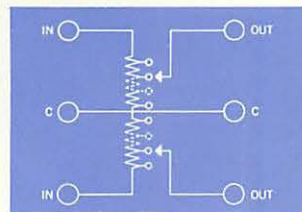

USED FOR HIGH IMPEDANCE
LEVEL CONTROL TO 2 GRIDS

Balanced "H" networks are simply two opposed "T" configurations to achieve grounding facility in balanced lines. They find use in measuring equipment, and are popular as submaster and master volume controls where higher levels are found and insertion losses are to be minimized. As mixers, read the later paragraph dealing with choice of mixer circuits.

"L"

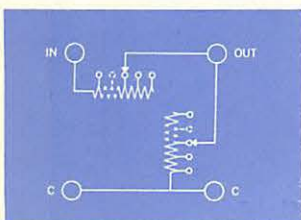

USED PRINCIPALLY
IN MEASURING EQUIPMENT

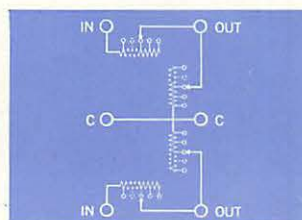

USED PRINCIPALLY
IN MEASURING EQUIPMENT

Potentiometers are voltage dividers. They find application as level controls in grid circuits at impedances of 25,000 ohms, 50,000 ohms and higher. Looking back into the line the resistance remains fairly constant, but into the succeeding circuit the resistance varies from zero to maximum. These units cannot be used satisfactorily as a mixer control in low impedance circuits because they change violently in impedance looking into the next circuit, thus affecting frequency response. In their usual application they are shielded by placement within the amplifier chassis, and the leads are kept as short as possible to reduce hum pickup as well as high frequency attenuation due to shunt capacitance. Where the first stage in an amplifier is push-pull a balanced potentiometer should be employed in the grid circuits.

The "L" circuit adapts itself to low impedance operation because the impedance looking in remains constant. Its principal use is found in measuring equipment although it finds application also at voice coil impedances in multiway loudspeaker systems as a level control for respective mid-bass, treble and vhf driver units.

ROTARY MIXERS AND ATTENUATORS

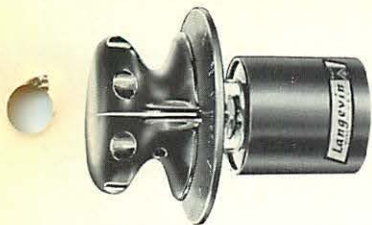

SINGLE

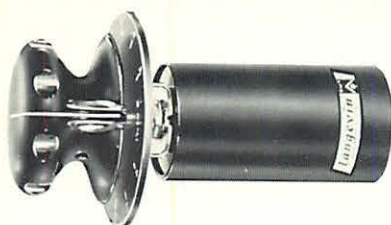

2-GANG

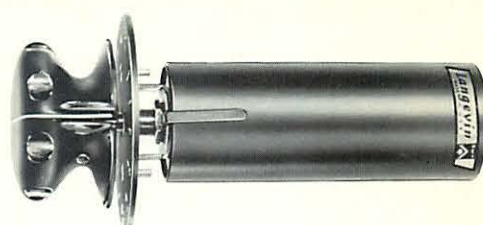

3-GANG

SMOOTH ACTION FOR EFFORT-FREE CONTROL

Only four grams of static friction need be overcome to accomplish rotation of Langevin Mixers. This applies also to Attenuators without detents. Effortless control is the result of long research into the mechanical requirements of friction-free bearings and brushes along with the employment of modern printed circuit techniques for the contact rows.

SUPER ACCURACY THROUGH PRINTED CIRCUITS

Correct contact positioning is guaranteed through printed circuitry derived from master layouts made on dividing heads. This insures satin-smooth, low-drag, bump-free action as the control is rotated.

LONG, TROUBLE-FREE LIFE IN EXCESS OF 1,000,000 CYCLES

Langevin controls have a life expectancy in excess of 1,000,000 cycles. Low, uniform contact pressures decrease wear and give decades of service.

SEALED AGAINST DIRT AND CORROSION

Langevin Mixers and Rotary Attenuators are pre-lubricated and sealed against moisture, corrosion and dirt for life-time use. Cycling and accelerated aging tests prove quiet operation for the life of the control.

FINE SILVER CONTACTS FOR LOW NOISE OPERATION

All contacts in Langevin Controls are fine silver. Silver is a noble metal and does not form noise producing oxides. Alloys such as nickel, nickel silver and

brass do form oxides, which are insulators and produce noise as time passes. Contrary to popular belief, the silver does not wear off of the contact, but, rather, galls and works its way into the pores of the base metal through usage. This increases conductivity and smoothness with age.

BRUSH CONTACT IS SOLID FINE SILVER

Brush contacts are also formed of silver. Thus, no thermal noise generation takes place between the contacts and brushes, further insuring quiet operation.

QUIET OPERATION IN LOW-LEVEL SERVICE

The combination of accurate printed circuitry for uniform contact, non-oxidizing silver and low brush pressures gives noise free operation at -130 dbm. This means satisfactory operation before preamplification for low-level service.

CUE CIRCUITS

Cue circuits are available on all mixers by simply adding a "Q" suffix to the type number when ordering. Add \$3.00 for Rotary Mixers and \$5.00 to Straight Line Mixers for this feature.

Net and Shipping Weight—Rotary Mixers and Attenuators

Diameter	Single		Double		Triple	
	Net	Shpg.	Net	Shpg.	Net	Shpg.
1½"	3 oz.	11 oz.	5 oz.	13 oz.	7 oz.	15 oz.
2¼"	5 oz.	13 oz.	8 oz.	1 lb.	10 oz.	1 lb. 2 oz.
3"	7 oz.	15 oz.	10 oz.	1 lb. 2 oz.	12 oz.	1 lb. 4 oz.

GENERAL DESCRIPTION

Langevin Rotary Mixers and Attenuators are available in three diameters, as well as in single, double and triple gangs for two and three channel stereo use. Printed circuitry is employed throughout for precision and uniformity. Contact decks are formed of non-hygrosopic phenolic, type FBE. Stainless steel shafts and brass bearings are used for long life, non-seizing properties, and to give friction-free action. Frames are formed of satin-black anodized aluminum. A universal mounting bracket allows replacement of all attenuators and mixers of alternate make because of three different mounting centers provided. These are 1¾", 1¼" and 1½". All connections are conveniently made to solder terminals at the rear of the control, facilitating wiring and making a neater ap-

pearance. An extra "C" center or common terminal is provided on each control to eliminate two wires to the usual "common".* This also gives balanced circuitry on the interior of the control, allows maximum cut-off, and eliminates crosstalk. In addition, this makes for easy test and wiring changes. Case grounds on all Langevin controls appear on another terminal, completely separated from signal ground, or "C" common. Controls are sealed against dirt, moisture and corrosion. All units are available with and without detents, with and without Cue Circuit.

*See other sections of Langevin literature dealing with recommended cabling practice where special attention is called to balanced grounds in mixer circuits.

DIMENSION CHART ALL UNITS

Frame Type	Dia. "A"	LENGTH "B"		
		Single	Double	Triple
1	1½"			
2	2¼"	1¾"	2¾"	4"
3	3"			

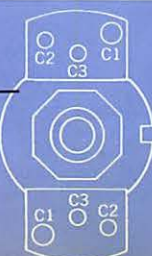

C1 - 1½ x 8/32
C2 - 1¼ x 6/32
C3 - 1¼ x 6/32
OR
SINGLE HOLE
¼ CLEARANCE

NOTE: BRACKET IS REMOVABLE FOR SINGLE 3/8" HOLE MOUNT

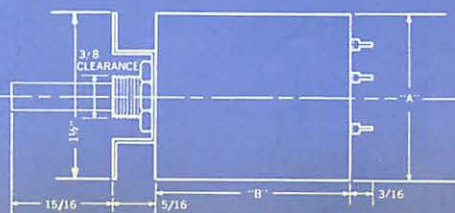

HOW TO ORDER — MIXERS AND ATTENUATORS

The "MX" prefix on the mixer attenuators denotes a "mixer" function. These controls are used to increase or decrease gain in the system. The mixer attenuator is linear in function for approximately three quarters of its rotation and tapers on the last steps to cut-off or infinity. Standard increase in attenuation is through CCW rotation. Detents are not standard with these attenuators and should be specified if desired; there is no added charge for detents. Dial plate readings are approximate.

The "MXP" prefix on these attenuators denotes "precision" so that the exact attenuation is read on the dial plate. These "MXP" attenuators are available only with detents, and are ideal for use as masters or submasters. **IMPEDANCES:** Standard in and out terminal impedances for unbalanced and balanced ladders are 30, 50, 125, 150, 200, 250, 500 and 600 ohms. Bridge "T" and balanced "H" are 125, 150, 200, 250, 500 and 600 ohms. Potentiometers, balanced potentiometers are 10K, 20K, 25K, 50K, 100K, 200K, 250K, and 500K ohms. Combinations of impedances in and out are also available. Standard impedance unless specified is 600 ohms in and out for all controls except potentiometers. Please specify impedance for potentiometers.

INSERTION LOSS: Insertion loss for unbalanced and balanced ladders is 6 db. This insertion loss can be reduced to 3 db by using a 1:2 ratio on the terminal impedance. (For example: 150/300 ohm). There is no insertion loss on the Bridge "T" and Balanced "H" units.

CUE CIRCUITS: Cue Circuits are available on all mixers by adding a "Q" to the prefix of the model number when ordering. (For example: "MXQ") The added charge is \$3.00 a single, \$6.00 two gang, \$9.00 three gang and \$12.00 for four gang units.

GROUNDING: Two grounding connections are provided. The ground terminal

located on the terminal board is case ground. A grounding lug over the ferrule provides a ground connection for the ferrule and shaft where the mixer attenuator is mounted on a non-conductive panel.

KNOB: Model K-108 knob is supplied with mixer attenuators. Size is 2 3/8" diameter by 1 1/2" high. Accepts standard shaft 1/4" diameter and comes complete with two Allen 8/32 set screws; normally supplied in black unless otherwise specified. If no knob is desired, please specify, and deduct from pricing sheet appended.

DIAL: 2 3/4" dials are supplied with all mixer attenuators. They are fabricated of 3/32" thick aluminum so that the component mounting screws will be flush with the dial face. Plates are anodized in flat black non-halation satin matte finish. Markings are etched with modern lettering to suit the mixer attenuator. 1 1/4" mounting centers are standard so that the screw heads are completely covered by the knob. Center hole in the dial is 3/8" clearance. Mounting holes are counter-sunk. If no dial is desired, please specify, and deduct allowance as shown on pricing sheets appended. 2 1/4" dials are also available with the same mounting dimensions. For special applications and replacement purposes other dials are available. See specifications and data on other pages covering dials.

MOUNTING: All mixer attenuators are provided with 3/8 x 32 x 5/16" long ferrule, tang and universal mounting bracket. When center hole mounting is desired, remove the universal mounting bracket and apply the accessory tang provided under the mounting nut so that the projection will engage a blind recess in the panel to prevent turning of the assembly. The universal mounting bracket has a provision for 1 1/2" center to center 8:32 tap, 1 3/8" center to center 6:32 tap and 1 1/4" center to center 6:32 tap. The tang is not required when the attenuator is used with the mounting bracket.

LENGTH: SINGLE 1 3/8"; 2 GANG 2 7/8"; 3 GANG 4"; 4 GANG 4"

RESISTOR ACCURACY 5%

LANGVIN MODEL	CIRCUIT	STEPS	DB PER STEP	DEGREES BETWEEN STEPS	TOTAL DEGREE OF ROTATION	DIAMETER	2 GANG MODEL	3 GANG MODEL	4 GANG MODEL
MX-201	Unbal. Ladder	20	2	15	300	1 1/2	MX-201/2	MX-201/3	MX-201/4
MX-206	Unbal. Ladder	30	1 1/2	11 1/4	337 1/2	1 1/2	MX-206/2	MX-206/3	MX-206/4
MX-207	Unbal. Ladder	30	2	11 1/4	337 1/2	1 1/2	MX-207/2	MX-207/3	MX-207/4
MX-203	Unbal. Ladder	32	1 1/2	10	320	1 1/2	MX-203/2	MX-203/3	MX-203/4
MX-205	Unbal. Ladder	45	1	7 1/2	337 1/2	2 1/4	MX-205/2	MX-205/3	MX-205/4
MX-202	Bal. Ladder	20	2	15	300	2 1/4	MX-202/2	MX-202/3	MX-202/4
MX-208	Bal. Ladder	30	1 1/2	11 1/4	337 1/2	2 1/4	MX-208/2	MX-208/3	MX-208/4
MX-204	Bal. Ladder	32	1 1/2	10	320	2 1/4	MX-204/2	MX-204/3	MX-204/4
MX-209	Bal. Ladder	45	1	7 1/2	337 1/2	2 1/4	MX-209/2	MX-209/3	MX-209/4
MX-601	Bridge T	20	2	15	300	2 1/4	MX-601/2	MX-601/3	MX-601/4
MX-600	Bridge T	30	1 1/2	11 1/4	337 1/2	2 1/4	MX-600/2	MX-600/3	MX-600/4
MX-603	Bridge T	30	2	11 1/4	337 1/2	2 1/4	MX-603/2	MX-603/3	MX-603/4
MX-602	Bridge T	32	1 1/2	10	320	2 1/4	MX-602/2	MX-602/3	MX-602/4
MX-606	Bridge T	45	1/2	7 1/2	337 1/2	2 1/4	MX-606/2	MX-606/3	MX-606/4
MX-607	Bridge T	45	3/4	7 1/2	337 1/2	2 1/4	MX-607/2	MX-607/3	MX-607/4
MX-625	Bridge T	45	1	7 1/2	337 1/2	2 1/4	MX-625/2	MX-625/3	MX-625/4
MX-604	Balanced H	20	2	15	300	2 1/4	Not Available	Not Available	Not Available
MX-605	Balanced H	32	1 1/2	10	320	2 1/4	Not Available	Not Available	Not Available
MX-612	Potentiometer	20	2	15	300	*1 1/2	MX-612/2	MX-612/3	MX-612/4
MX-624	Potentiometer	30	1 1/2	11 1/4	337 1/2	*1 1/2	MX-624/2	MX-624/3	MX-624/4
MX-632	Potentiometer	30	2	11 1/4	337 1/2	*1 1/2	MX-632/2	MX-632/3	MX-632/4
MX-618	Potentiometer	32	1 1/2	10	320	*1 1/2	MX-618/2	MX-618/3	MX-618/4
MX-641	Potentiometer	45	1	7 1/2	337 1/2	**2 1/4	MX-641/2	MX-641/3	MX-641/4
MX-610	Dual Pot	20	2	15	300	**2 1/4	MX-610/2	MX-610/3	MX-610/4
MX-627	Dual Pot	30	1 1/2	11 1/4	337 1/2	**2 1/4	MX-627/2	MX-627/3	MX-627/4
MX-634	Dual Pot	30	2	11 1/4	337 1/2	**2 1/4	MX-634/2	MX-634/3	MX-634/4
MX-615	Bal. Pot	20	2	15	300	**2 1/4	MX-615/2	MX-615/3	MX-615/4
MX-621	Bal. Pot	32	1 1/2	10	320	**2 1/4	MX-621/2	MX-621/3	MX-621/4
MX-642	Bal. Pot	45	1	7 1/2	337 1/2	**2 1/4	MX-642/2	MX-642/3	MX-642/4

Detented Condition for Standard Mixer Attenuators Precision Steps. Detents are standard. Cue Position

*When Ordering with cue position, the diameter is 2 1/4".
**When Ordering with cue position, the length is 2 7/8" and only available as a single.

NOTE: 1. For impedance definition, see impedance code chart on page 60.
2. Number of steps or decibel steps other than those shown are available.

LANGVIN IMPEDANCE CODE

SUFFIX LETTER	IMPEDANCE (OHMS)	SUFFIX LETTER	IMPEDANCE (OHMS)	SUFFIX LETTER	IMPEDANCE (OHMS)	SUFFIX LETTER	IMPEDANCE (OHMS)
A	30/30	H	60/60	O	6900	V	7500
B	50/50	I	7100	P	20,000	W	200,000
C	125/125	J	100/100	Q	Prefix for "Cue"	X	250,000
D	200/200	K	150/150	R	25,000	Y	500,000
E	250/250	L	5000	S	50,000	Z	1,000,000
F	500/500	M	10,000	T	100,000		
G	600/600	N	300/300	U	3900		

NOTE: Impedances not shown must be specified.

VU RANGE EXTENDERS

VU meters are adjusted to 3900 ohms. Rotary range extenders should be of the "T" configuration and 3900 ohms impedance. In order properly to read +4 VU a 3600 ohm series resistor is required. Langevin Bridge "T" attenuators for such applications provide two fixed resistors in series, one of 3300 ohms and the other of 300 ohms, the terminals of which appear on the back plate of the VU Range Extender Attenuator. This permits the use of the Langevin Model VR-111 Variable Wire-Wound Resistor for stereo balance or calibration by selecting the appropriate solder terminal.

All units are shipped complete with engraved dial and Langevin Model K-108 RCA Type Knob.

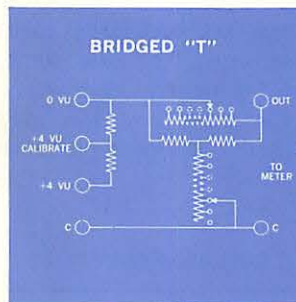

RESISTOR ACCURACY 1%

— LENGTH: SINGLE 1 5/8"; 2 GANG 2 7/8"; 3 GANG 4"; 4 GANG 4"

LANGEVIN MODEL	STEPS	DB PER STEP	IMPEDANCE	RANGE	DEGREES BETWEEN STEPS	TOTAL DEGREE ROTATION	NOTE	DIAMETER	2 GANG	3 GANG	4 GANG
									MODEL	MODEL	MODEL
ATX-300/VU	10	1	7500/3900	+4 to +14	15	150	1	1 1/2	ATX-300/2VU	ATX-300/3VU	ATX-300/4VU
ATX-301/VU	10	2	7500/3900	+4 to +24	15	150	1	1 1/2	ATX-301/2VU	ATX-301/3VU	ATX-301/4VU
ATX-309/IU	12	2	7100/3900	1 MW +4 to +24 & Off	15	180	2	2 1/4	ATX-309/2IU	ATX-309/3IU	ATX-309/4IU
ATX-310/VU	12	2	7500/3900	1 MW +4 to +24 & Off	15	180	1	2 1/4	ATX310/2VU	ATX-310/3VU	ATX-310/4VU
ATX-311/U	12	2	3900/3900	+4 to +26 & Off	15	180	3	2 1/4	ATX-311/2U	ATX-311/3U	ATX-311/4U
ATX-312/IU	12	2	7100/3900	+4 to +26 & Off	15	180	2	2 1/4	ATX-312/2IU	ATX-312/3IU	ATX-312/4IU
ATX-320/VU	12	2	7500/3900	+4 to +26 & Off	15	180	1	2 1/4	ATX-320/2VU	ATX-320/3VU	ATX-320/4VU
ATX-305/VU	15	2	7500/3900	+4 to +34	15	225	1	2 1/4	ATX-305/2VU	ATX-305/3VU	ATX-305/4VU
ATX-303/VU	20	2	7500/3900	+4 to +44	15	300	1	2 1/4	ATX-303/2VU	ATX-303/3VU	ATX-303/4VU
ATX-314/IU	20	2	7100/3900	1 MW +4 to +40 & Off	15	300	2	2 1/4	ATX-314/2IU	ATX-314/3IU	ATX-314/4IU
ATX-315/VU	20	2	7500/3900	1 MW +4 to +40 & Off	15	300	1	2 1/4	ATX-315/2VU	ATX-315/3VU	ATX-315/4VU
ATX-316/OU	20	2	6900/3900	1 MW +4 to +40 & Off	15	300	2	2 1/4	ATX-316/2OU	ATX-316/3OU	ATX-316/4OU
ATX-317/IU	20	2	7100/3900	+4 to +42 & Off	15	300	2	2 1/4	ATX-317/2IU	ATX-317/3IU	ATX-317/4IU
ATX-318/U	20	2	3900/3900	+4 to +42 & Off	15	300	3	2 1/4	ATX-318/2U	ATX-318/3U	ATX-318/4U
ATX-321/VU	20	2	7500/3900	+4 to +42 & Off	15	300	1	2 1/4	ATX-321/2VU	ATX-321/3VU	ATX-321/4VU
ATX-304/VU	30	1	7500/3900	+4 to +34	10	300	1	2 1/4	ATX-304/2VU	ATX-304/3VU	ATX-304/4VU

- NOTE: 1. No Zero Adjust Rheostat Required
2. Zero Adjust Rheostat Required (Langevin Model VR111)
3. External 3600 ohm Resistor Required

For Impedance definition, see impedance code chart on page 60
Other number of steps, decibels per step or special meter multipliers other than those shown are available.

MOTION PICTURE PROJECTION AND TURNTABLE FADERS

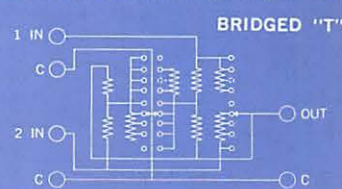
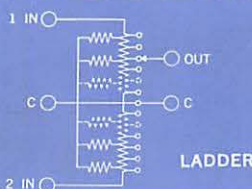
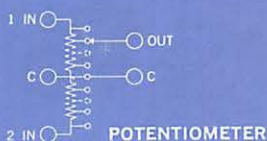

Purpose: Faders are employed in motion picture projection to blend the sound from one machine to another as changeover in picture occurs. They are used also in sound effects consoles and in radio broadcast turntables to blend from one recording to another in a continuous rotary motion.

Langevin Faders are available in matched ladder as well as grid control.

The calibrated dials are marked white operator left side and red right side of infinity center. These controls are normally supplied without detent but may be ordered with detent by so specifying. Impedances up to 600 ohms are supplied as well as values up to 500,000 ohms for potentiometers; please specify when ordering.

LENGTH: SINGLE 1 5/8"; 2 GANG 2 7/8"

RESISTOR ACCURACY 1%

LANGEVIN MODEL	CIRCUIT	NO. OF STEPS EACH SIDE OF INFINITY	TOTAL NUMBER OF STEPS	DB PER STEP	TOTAL DB LOSS EACH SIDE OF INFINITY	RANGE	DEGREES BETWEEN STEPS	TOTAL DEGREE OF ROTATION	DIAMETER	2 GANG MODEL
AT-201	Unbal. Ladder	15	31	3	45	0-45-∞-45-0	10	310	1 1/2	AT-201/2
AT-203	Unbal. Ladder	22	45	2	44	0-44-∞-44-0	7 1/2	337 1/2	2 1/4	AT-203/2
AT-207	Bridge T	15	31	3	45	0-45-∞-45-0	10	310	2 1/4	AT-207/2
AT-204	Bridge T	22	45	2	44	0-44-∞-44-0	7 1/2	337 1/2	2 1/4	AT-204/2
AT-200	Potentiometer	15	31	3	45	0-45-∞-45-0	10	310	1 1/2	AT-200/2
AT-202	Potentiometer	22	45	2	44	0-44-∞-44-0	7 1/2	337 1/2	2 1/4	AT-202/2

- Note: 1. For impedance definition, see impedance code chart on page 60.
2. Number of steps or decibel steps other than shown are available.

For price information, see price sheet appended.

TRANSMISSION LINE ATTENUATORS AND GAIN CONTROLS

GENERAL

Transmission line attenuators and gain controls have the same general characteristics of mixer controls except that they differ in two details because of their employment. First, detents are ordinarily used to facilitate return to exact settings; "T" and some balanced "H" units are used frequently as masters and submasters because of the zero insertion loss feature. Secondly, they are used without taper and "off" position.

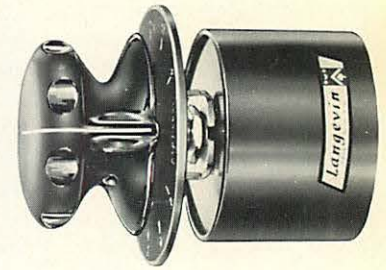
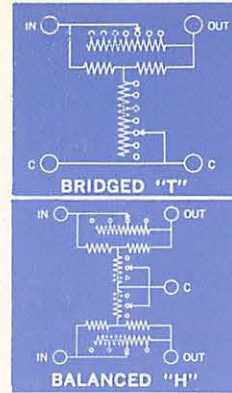

LENGTH: SINGLE 1 5/8"; 2 GANG 2 7/8"; 3 GANG 4"; 4 GANG 4"

RESISTOR ACCURACY 1%

LANGEVIN MODEL	CIRCUIT	STEPS	DB PER STEP	TOTAL DB LOSS	DEGREES BETWEEN STEPS	TOTAL DEGREE OF ROTATION	DIAMETER	2 GANG MODEL	3 GANG MODEL	4 GANG MODEL
AT-618	Unbal. Ladder	20	1 1/2	30	15	300	1 1/2	AT-618/2	AT-618/3	AT-618/4
AT-631	Unbal. Ladder	20	2	60	15	300	1 1/2	AT-631/2	AT-631/3	AT-631/4
AT-634	Unbal. Ladder	30	1 1/2	45	11 1/4	337 1/2	1 1/2	AT-634/2	AT-634/3	AT-634/4
AT-635	Unbal. Ladder	30	2	60	11 1/4	337 1/2	1 1/2	AT-635/2	AT-635/3	AT-635/4
AT-624	Unbal. Ladder	45	1	45	7 1/2	337 1/2	2 1/4	AT-624/2	AT-624/3	AT-624/4
AT-632	Bal. Ladder	20	1 1/2	30	11 1/4	337 1/2	2 1/4	AT-632/2	AT-632/3	AT-632/4
AT-633	Bal. Ladder	20	2	40	11 1/4	337 1/2	2 1/4	AT-633/2	AT-633/3	AT-633/4
AT-638	Bal. Ladder	30	1 1/2	45	11 1/4	337 1/2	2 1/4	AT-638/2	AT-638/3	AT-638/4
AT-639	Bal. Ladder	30	2	60	11 1/4	337 1/2	2 1/4	AT-639/2	AT-639/3	AT-639/4
AT-640	Bal. Ladder	45	1	45	7 1/2	337 1/2	2 1/4	AT-640/2	AT-640/3	AT-640/4
AT-612	Bridge T	10	1/10	1	15	150	1 1/2	AT-612/2	AT-612/3	AT-612/4
AT-613	Bridge T	10	1/2	5	15	150	1 1/2	AT-613/2	AT-613/3	AT-613/4
AT-606	Bridge T	10	1	10	15	150	1 1/2	AT-606/2	AT-606/3	AT-606/4
AT-652	Bridge T	10	1 1/2	15	15	150	1 1/2	AT-652/2	AT-652/3	AT-652/4
AT-600	Bridge T	10	2	20	15	150	1 1/2	AT-600/2	AT-600/3	AT-600/4
AT-614	Bridge T	20	1/10	2	15	300	2 1/4	AT-614/2	AT-614/3	AT-614/4
AT-629	Bridge T	20	1/2	10	15	300	2 1/4	AT-629/2	AT-629/3	AT-629/4
AT-607	Bridge T	20	1	20	15	300	2 1/4	AT-607/2	AT-607/3	AT-607/4
AT-641	Bridge T	20	1 1/2	30	15	300	2 1/4	AT-641/2	AT-641/3	AT-641/4
AT-601	Bridge T	20	2	40	15	300	2 1/4	AT-601/2	AT-601/3	AT-601/4
AT-642	Bridge T	20	3	60	15	300	2 1/4	AT-642/2	AT-642/3	AT-642/4
AT-615	Bridge T	30	1/10	3	10	300	2 1/4	AT-615/2	AT-615/3	AT-615/4
AT-643	Bridge T	30	1/10	3	11 1/4	337 1/2	2 1/4	AT-643/2	AT-643/3	AT-643/4
AT-623	Bridge T	30	1/2	15	10	300	2 1/4	AT-623/2	AT-623/3	AT-623/4
AT-644	Bridge T	30	1/2	15	11 1/4	337 1/2	2 1/4	AT-644/2	AT-644/3	AT-644/4
AT-608	Bridge T	30	1	30	10	300	2 1/4	AT-608/2	AT-608/3	AT-608/4
AT-627	Bridge T	30	1	30	11 1/4	337 1/2	2 1/4	AT-627/2	AT-627/3	AT-627/4
AT-645	Bridge T	30	1 1/2	45	10	300	2 1/4	AT-645/2	AT-645/3	AT-645/4
AT-646	Bridge T	30	1 1/2	45	11 1/4	337 1/2	2 1/4	AT-646/2	AT-646/3	AT-646/4
AT-602	Bridge T	30	2	60	10	300	2 1/4	AT-602/2	AT-602/3	AT-602/4
AT-647	Bridge T	30	2	60	11 1/4	337 1/2	2 1/4	AT-647/2	AT-647/3	AT-647/4
AT-636	Bridge T	45	1/2	22 1/2	7 1/2	337 1/2	2 1/4	AT-636/2	AT-636/3	AT-636/4
AT-637	Bridge T	45	1	45	7 1/2	337 1/2	2 1/4	AT-637/2	AT-637/3	AT-637/4
AT-616	Balanced H	10	1/10	1	15	150	2 1/4	AT-616/2	AT-616/3	AT-616/4
AT-617	Balanced H	10	1/2	5	15	150	2 1/4	AT-617/2	AT-617/3	AT-617/4
AT-609	Balanced H	10	1	10	15	150	2 1/4	AT-609/2	AT-609/3	AT-609/4
AT-648	Balanced H	10	1 1/2	15	15	150	2 1/4	AT-648/2	AT-648/3	AT-648/4
AT-603	Balanced H	10	2	20	15	150	2 1/4	AT-603/2	AT-603/3	AT-603/4
AT-649	Balanced H	20	1/10	2	15	300	2 1/4		NOT AVAILABLE	
AT-650	Balanced H	20	1/2	10	15	300	2 1/4		NOT AVAILABLE	
AT-610	Balanced H	20	1	20	15	300	2 1/4		NOT AVAILABLE	
AT-651	Balanced H	20	1 1/2	30	15	300	2 1/4		NOT AVAILABLE	
AT-604	Balanced H	20	2	40	15	300	2 1/4		NOT AVAILABLE	
AT-653	Balanced H	30	1/10	3	10	300	2 1/4		NOT AVAILABLE	
AT-655	Balanced H	30	1/10	3	11 1/4	337 1/2	2 1/4		NOT AVAILABLE	
AT-656	Balanced H	30	1/2	15	10	300	2 1/4		NOT AVAILABLE	
AT-657	Balanced H	30	1/2	15	11 1/4	337 1/2	2 1/4		NOT AVAILABLE	
AT-611	Balanced H	30	1	30	10	300	2 1/4		NOT AVAILABLE	
AT-658	Balanced H	30	1	30	11 1/4	337 1/2	2 1/4		NOT AVAILABLE	
AT-659	Balanced H	30	1 1/2	45	10	300	2 1/4		NOT AVAILABLE	
AT-660	Balanced H	30	1 1/2	45	11 1/4	337 1/2	2 1/4		NOT AVAILABLE	
AT-605	Balanced H	30	2	60	10	300	2 1/4		NOT AVAILABLE	
AT-661	Balanced H	30	2	60	11 1/4	337 1/2	2 1/4		NOT AVAILABLE	

ORDERING INFORMATION

ATV — Denotes last step is infinity.

ATQ — Cue position.

For example, an AT618/G is an unbalanced ladder, 20 step, 2 db per step, 600/600 ohm.
 Example #2: ATV618/2G is the same specification except, last step is infinity, two gang.
 Example #3: ATQ618/2G is the same specification except with cue position.

Note: 1. For impedance definition, see impedance code chart on page 60.
 2. Number of steps or decibel steps other than those shown are available.

GENERAL CONSIDERATIONS

The most common measuring device in transmission work is the gain set. From this device simpler forms of measuring transmission levels are derived.

A gain set consists of an oscillator, a facility for matching the impedance of the input to the equipment or circuit under test, a series of decade attenuators, and another impedance matching facility for receiving the results of the test along with suitable metering.

On this page we are concerned only with the impedance matching controls calibrated for relative losses due to matching of unequal impedance ratios. These controls are treated on first, and are then followed by the decade attenuators on the next page.

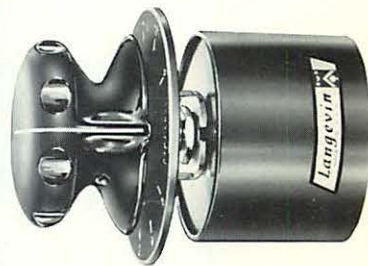
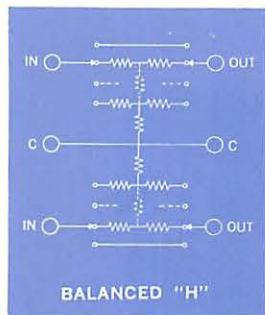
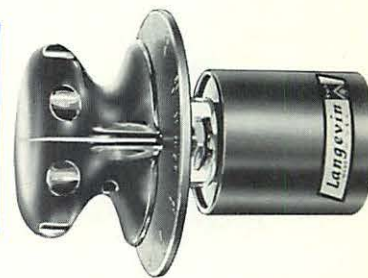
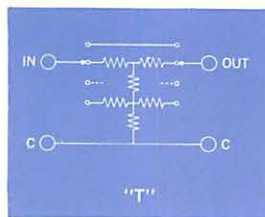

ROTARY IMPEDANCE MATCHING NETWORKS

Langevin Rotary Impedance Matching Controls consist of a series of "T" and "H" networks without taper and offer a constant impedance to the input with a series of varied impedances on the output. These controls are reversible by simply exchanging input and output leads, thus allowing them to match either input or output circuit impedances.

In the form of a gain control the balanced "H" units are actually two bridged "T" units opposing

each other to offer a balanced circuit to common center or ground. This type of "H" circuit utilizes four brushes to achieve its purpose.

Since these circuits permit high precision they form the ideal method of matching impedance in gain sets and other equipment requiring extreme accuracy. The same standards of construction are employed on these units as in other Langevin controls. They do not introduce phase shift, and leakage is low. At 100 kc no measurable leakage is evidenced.

PRECISION ROTARY IMPEDANCE MATCHING NETWORK

RESISTOR ACCURACY 1/2%
WATTS SINE WAVE 1/2 WATT

DB LOSS AT OUTPUT Z OF

DEGREES BETWEEN POSITIONS: 15°
TOTAL DEGREE OF ROTATION: 120°

LANGEVIN MODEL	CIRCUIT	INPUT IMPEDANCE	30	50	125	150	200	250	500	600	DIAMETER	LENGTH
AT-404/G	T	600	20	20	15	15	10	10	5	0	1 1/2	1 5/8
AT-400/G	T	600	20	20	20	20	10	10	10	0	1 1/2	1 5/8
AT-401/G	T	600	20	20	20	20	20	20	20	20	1 1/2	1 5/8
AT-405/F	T	500	20	20	15	15	10	10	0	5	1 1/2	1 5/8
AT-406/F	T	500	20	20	20	20	20	20	20	20	1 1/2	1 5/8
AT-407/N	T	300	20	15	10	10	10	5	10	10	1 1/2	1 5/8
AT-408/N	T	300	20	20	20	20	20	20	20	20	1 1/2	1 5/8
AT-409/K	T	150	15	10	5	0	5	10	15	15	1 1/2	1 5/8
AT-410/K	T	150	15	15	15	15	15	15	15	15	1 1/2	1 5/8
AT-411/G	H	600	20	20	15	15	10	10	5	0	2 1/4	1 5/8
AT-402/G	H	600	20	20	20	20	10	10	10	0	2 1/4	1 5/8
AT-403/G	H	600	20	20	20	20	20	20	20	20	2 1/4	1 5/8
AT-412/F	H	500	20	20	15	15	10	10	0	5	2 1/4	1 5/8
AT-413/F	H	500	20	20	20	20	20	20	20	20	2 1/4	1 5/8
AT-414/N	H	300	20	15	10	10	10	5	10	10	2 1/4	1 5/8
AT-415/N	H	300	20	20	20	20	20	20	20	20	2 1/4	1 5/8
AT-416/K	H	150	15	10	5	0	5	10	15	15	2 1/4	1 5/8
AT-417/K	H	150	15	15	15	15	15	15	15	15	2 1/4	1 5/8

Note: 1. For impedance definition, see impedance code chart on page 60.
2. Number of steps or impedances other than those shown are available.

For price information, see price sheet appended.

MEASURING EQUIPMENT — PRECISION DECADE ATTENUATORS

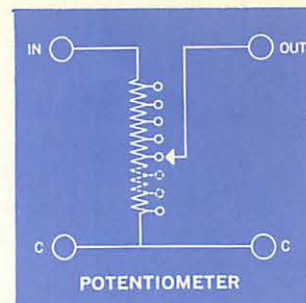
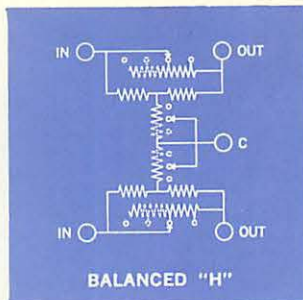
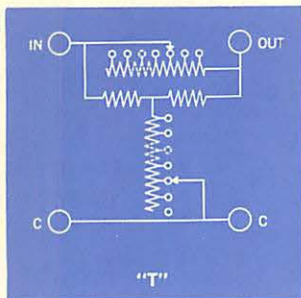

PRECISION DECADE ATTENUATORS

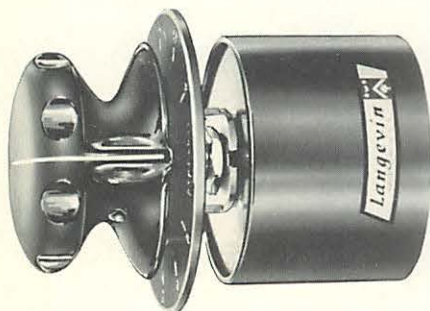

The Langevin Series 500 Precision Decade Attenuators are 10 step units for use in transmission measuring equipment such as gain sets. They are also ideal for use in noise meters and audiometers; for these equipments they are offered in potentiometers as well as "T" and balanced "H" configurations. All resistors are calibrated to better than $\pm 1/2\%$. For best results, steady sine wave power input levels should be limited to 1 watt or less to insure accuracy over an indefinite period. 5 watts of program material can be handled for an unlimited time. Units capable of higher levels are available on order.

10 STEPS .1DB 1 DB TOTAL LENGTH: SINGLE 1 5/8"; 2 GANG 2 7/8"; 3 GANG 4"; 4 GANG 4"

RESISTOR ACCURACY 1/2%

LANGEVIN MODEL	CIRCUIT	IMPEDANCE	STEPS	DB PER STEP	TOTAL DB LOSS	DEGREES BETWEEN STEPS	TOTAL DEGREE OF ROTATION	DIAMETER	2 GANG MODEL	3 GANG MODEL	4 GANG MODEL
AT-515/K	T	150	10	1/10	1	15	150	2 1/4	AT-515/2K	AT-515/3K	AT-515/4K
AT-518/F	T	500	10	1/10	1	15	150	2 1/4	AT-518/2F	AT-518/3F	AT-518/4F
AT-500/G	T	600	10	1/10	1	15	150	2 1/4	AT-500/2G	AT-500/3G	AT-500/4G
AT-521/K	H	150	10	1/10	1	15	150	2 1/4	AT-521/2K	AT-521/3K	AT-521/4K
AT-524/F	H	500	10	1/10	1	15	150	2 1/4	AT-524/2F	AT-524/3F	AT-524/4F
AT-501/G	H	600	10	1/10	1	15	150	2 1/4	AT-501/2G	AT-501/3G	AT-501/4G
AT-502/R	Potentiometer	25K	10	1/10	1	15	150	2 1/4	AT-502/2R	AT-502/3R	AT-502/4R
AT-503/S	Potentiometer	50K	10	1/10	1	15	150	2 1/4	AT-503/2S	AT-503/3S	AT-503/4S
AT-504/T	Potentiometer	100K	10	1/10	1	15	150	2 1/4	AT-504/2T	AT-504/3T	AT-504/4T
AT-527/W	Potentiometer	200K	10	1/10	1	15	150	2 1/4	AT-527/2W	AT-527/3W	AT-527/4W

10 STEPS 1DB 10 DB TOTAL

LANGEVIN MODEL	CIRCUIT	IMPEDANCE	STEPS	DB PER STEP	TOTAL DB LOSS	DEGREES BETWEEN STEPS	TOTAL DEGREE OF ROTATION	DIAMETER	2 GANG MODEL	3 GANG MODEL	4 GANG MODEL
AT-516/K	T	150	10	1	10	15	150	2 1/4	AT-516/2K	AT-516/3K	AT-516/4K
AT-519/F	T	500	10	1	10	15	150	2 1/4	AT-519/2F	AT-519/3F	AT-519/4F
AT-505/G	T	600	10	1	10	15	150	2 1/4	AT-505/2G	AT-505/3G	AT-505/4G
AT-522/K	H	150	10	1	10	15	150	2 1/4	AT-522/2K	AT-522/3K	AT-522/4K
AT-525/F	H	500	10	1	10	15	150	2 1/4	AT-525/2F	AT-525/3F	AT-525/4F
AT-506/G	H	600	10	1	10	15	150	2 1/4	AT-506/2G	AT-506/3G	AT-506/4G
AT-507/R	Potentiometer	25K	10	1	10	15	150	2 1/4	AT-507/2R	AT-507/3R	AT-507/4R
AT-508/S	Potentiometer	50K	10	1	10	15	150	2 1/4	AT-508/2S	AT-508/3S	AT-508/4S
AT-509/T	Potentiometer	100K	10	1	10	15	150	2 1/4	AT-509/2T	AT-509/3T	AT-509/4T
AT-528/W	Potentiometer	200K	10	1	10	15	150	2 1/4	AT-528/2W	AT-528/3W	AT-528/4W

10 STEPS 10DB 100 DB TOTAL

LANGEVIN MODEL	CIRCUIT	IMPEDANCE	STEPS	DB PER STEP	TOTAL DB LOSS	DEGREES BETWEEN STEPS	TOTAL DEGREE OF ROTATION	DIAMETER	2 GANG MODEL	3 GANG MODEL	4 GANG MODEL
AT-517/K	T	150	10	10	100	15	150	2 1/4	AT-517/2K	AT-517/3K	AT-517/4K
AT-520/F	T	500	10	10	100	15	150	2 1/4	AT-520/2F	AT-520/3F	AT-520/4F
AT-510/G	T	600	10	10	100	15	150	2 1/4	AT-510/2G	AT-510/3G	AT-510/4G
AT-523/K	H	150	10	10	100	15	150	2 1/4	AT-523/2K	AT-523/3K	AT-523/4K
AT-526/F	H	500	10	10	100	15	150	2 1/4	AT-526/2F	AT-526/3F	AT-526/4F
AT-511/G	H	600	10	10	100	15	150	2 1/4	AT-511/2G	AT-511/3G	AT-511/4G
AT-512/R	Potentiometer	25K	10	10	100	15	150	2 1/4	AT-512/2R	AT-512/3R	AT-512/4R
AT-513/S	Potentiometer	50K	10	10	100	15	150	2 1/4	AT-513/2S	AT-513/3S	AT-513/4S
AT-514/T	Potentiometer	100K	10	10	100	15	150	2 1/4	AT-514/2T	AT-514/3T	AT-514/4T
AT-529/W	Potentiometer	200K	10	10	100	15	150	2 1/4	AT-529/2W	AT-529/3W	AT-529/4W

NOTE: 1. For impedance definitions, see impedance code chart on page 60.
2. Number of steps or decibel steps other than those shown are available.

For price information, see price sheet appended.

GRID CONTROL POTENTIOMETERS

PRECAUTIONS IN CHOOSING IMPEDANCES

The potentiometers listed in this section are designed to insure calibration into an open circuit such as the grid of a Class "A" amplifier tube.

In choosing the proper resistance of the potentiometer for your application make certain that the lowest possible value is chosen. A number of reasons for this exist. In a high gain triode the grid input impedance at the highest frequencies may be quite low, thus requiring a low value of potentiometer resistance of about 50,000 ohms.

In addition the capacity of the input circuit to ground governs high frequency attenuation. The lower the value of the potentiometer, the smaller is this effect.

In good transmission design high impedance leads should be limited to inches in length and kept as short as possible. A line to grid transformer is always recommended, with the potentiometer on the amplifier side of the coil. Make certain that no grid current is flowing or the potentiometer will be noisy in operation.

TYPES OFFERED

Langevin grid control potentiometers are offered unbalanced for single grids and in balanced configurations for push-pull grids. These are normally supplied without taper and with no "off" position. All

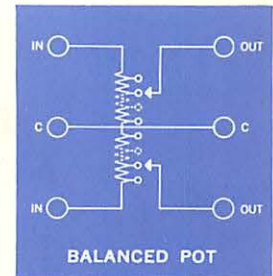
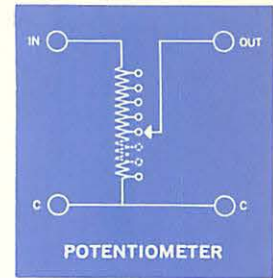
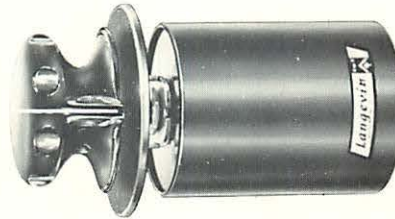
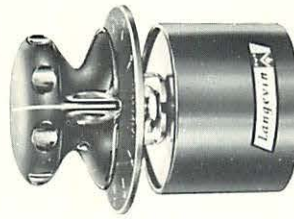

units are detented; if desired without detents please specify.

LENGTH: SINGLE 1 7/8"; 2 GANG 2 7/8"; 3 GANG 4"; 4 GANG 4"

RESISTOR ACCURACY 1%

LANGVIN MODEL	CIRCUIT	STEPS	DB PER STEP	TOTAL DB LOSS	DEGREES BETWEEN STEPS	TOTAL DEGREE OF ROTATION	NOTE	DIAMETER	2 GANG MODEL	3 GANG MODEL	4 GANG MODEL
GC-333	Potentiometer	10	5	50	15	150	1	1 1/2	GC-333/2	GC-333/3	GC-333/4
GC-334	Potentiometer	15	5	75	15	225	1	1 1/2	GC-334/2	GC-334/3	GC-334/4
GC-349	Potentiometer	20	1 1/2	30	15	300	1	1 1/2	GC-349/2	GC-349/3	GC-349/4
GC-335	Potentiometer	20	2	40	15	300	1	1 1/2	GC-335/2	GC-335/3	GC-335/4
GC-357	Potentiometer	20	3	60	15	300	1	1 1/2	GC-357/2	GC-357/3	GC-357/4
GC-361	Potentiometer	20	5	100	15	300	1	1 1/2	GC-361/2	GC-361/3	GC-361/4
GC-337	Potentiometer	30	1	30	10	300	1	1 1/2	GC-337/2	GC-337/3	GC-337/4
GC-369	Potentiometer	30	1	30	11 1/4	337 1/2	1	1 1/2	GC-369/2	GC-369/3	GC-369/4
GC-373	Potentiometer	30	1 1/2	45	10	300	1	1 1/2	GC-373/2	GC-373/3	GC-373/4
GC-377	Potentiometer	30	1 1/2	45	11 1/4	337 1/2	1	1 1/2	GC-377/2	GC-377/3	GC-377/4
GC-338	Potentiometer	30	2	60	10	300	1	1 1/2	GC-338/2	GC-338/3	GC-338/4
GC-385	Potentiometer	30	2	60	11 1/4	337 1/2	1	1 1/2	GC-385/2	GC-385/3	GC-385/4
GC-339	Potentiometer	45	1	45	7 1/2	337 1/2	2	2 1/4	GC-339/2	GC-339/3	GC-339/4
GC-315	Dual Pot	10	5	50	15	150	2	2 1/4	GC-315/2	GC-315/3	GC-315/4
GC-319	Dual Pot	15	5	75	15	225	2	2 1/4	GC-319/2	GC-319/3	GC-319/4
GC-351	Dual Pot	20	1 1/2	30	15	300	2	2 1/4	GC-351/2	GC-351/3	GC-351/4
GC-355	Dual Pot	20	2	40	15	300	2	2 1/4	GC-355/2	GC-355/3	GC-355/4
GC-359	Dual Pot	20	3	60	15	300	2	2 1/4	GC-359/2	GC-359/3	GC-359/4
GC-363	Dual Pot	20	5	100	15	300	2	2 1/4	GC-363/2	GC-363/3	GC-363/4
GC-367	Dual Pot	30	1	30	10	300	2	2 1/4	GC-367/2	GC-367/3	GC-367/4
GC-371	Dual Pot	30	1	30	11 1/4	337 1/2	2	2 1/4	GC-371/2	GC-371/3	GC-371/4
GC-375	Dual Pot	30	1 1/2	45	10	300	2	2 1/4	GC-375/2	GC-375/3	GC-375/4
GC-379	Dual Pot	30	1 1/2	45	11 1/4	337 1/2	2	2 1/4	GC-379/2	GC-379/3	GC-379/4
GC-383	Dual Pot	30	2	60	10	300	2	2 1/4	GC-383/2	GC-383/3	GC-383/4
GC-387	Dual Pot	30	2	60	11 1/4	337 1/2	2	2 1/4	GC-387/2	GC-387/3	GC-387/4
GC-391	Dual Pot	45	1	45	7 1/2	337 1/2	2	2 1/4	GC-391/2	GC-391/3	GC-391/4

ORDERING INFORMATION

GCV — Denotes last step is infinity.
GCQ — Cue Position.

For example, a GC333/M is a potentiometer, 10 step, 5 db per step, 10,000 ohm.
Example #2: GCV333/M is the same specification except, last step infinity.
Example #3: GCVQ333/M is the same specification except with cue position.

For impedance definition, see impedance code chart on page 60.
Number of steps or decibel steps other than those shown are available.

Note: 1. When ordering with cue position, the diameter is 2 1/4".
2. When ordering with cue position, the length is 2 7/8" and only available as a single.

For price information, see price sheet appended.

FIXED ATTENUATOR NETWORKS

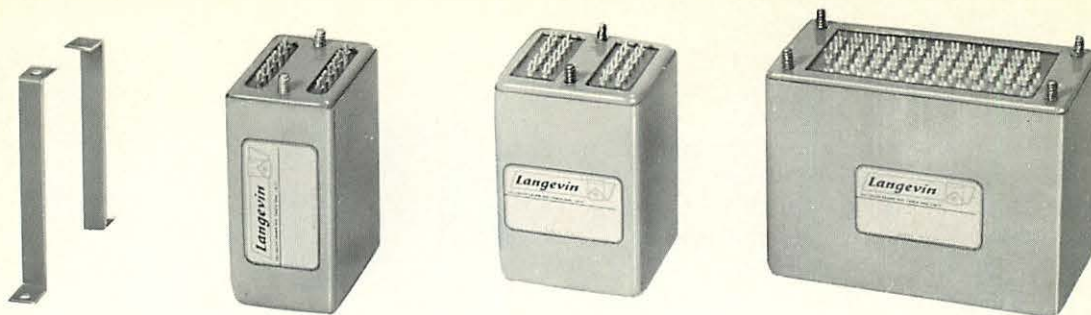

MIXER NETWORKS

TERMINATING RESISTORS FIXED LOSS NETWORKS

MINIMUM LOSS MATCHING NETWORKS V U MULTIPLIERS

GENERAL

Fixed attenuators, comprising resistance networks, or "pads", have varied uses in transmission work. For ease in classification these are broken down according to employment into six general groups in the sections to follow. It will be seen that many network configurations are used in unbalanced lines, and the diagrams and formulae for computation head the respective sections dealing with each. The Voltage Ratio Table on page 67 shows the value of K to be used in the equations.

uniform in depth and height; only the width varies to accommodate more circuit elements. In this way the required components for the entire circuit array may be grouped and mounted uniformly, conserving space and simplifying cable forms. All solder terminals are plainly marked and arranged for neat appearance and convenience in service and test. Resistances in networks are held to $\pm 1\%$ and are potted in sealing compound for long life.

DESCRIPTION

Containers for all Langevin Fixed Pads, Line to Line coils, Fixed Oscillators, and other components are

Balanced networks in all forms are derived by dividing series arm resistors by one half and inserting them in each side of the line.

MOUNTING DIMENSIONS

Three container widths are used on all appropriate Langevin components. Mounting is facilitated by brackets furnished with each unit. If it is desired to

use cutouts in the mounting surface for concealed cabling, the cases may be inverted so that terminations emerge from the bottom.

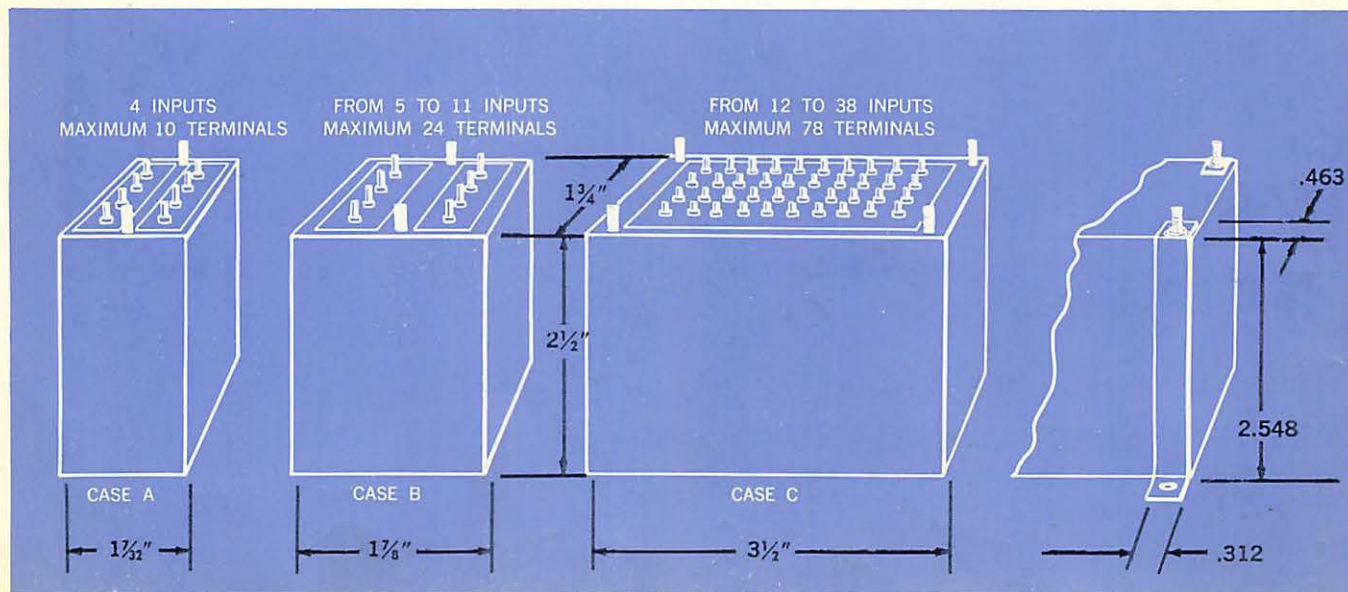

VOLTAGE RATIO TABLE

V

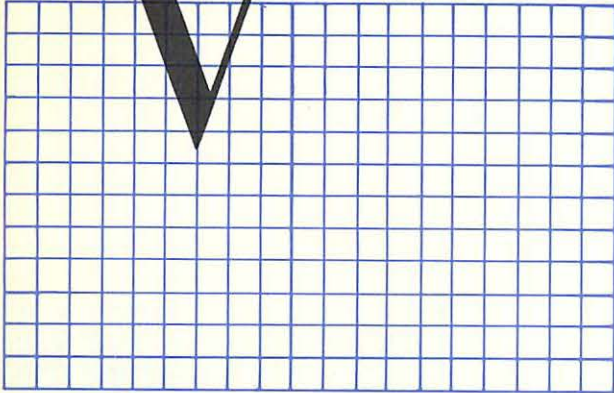

Here is a tool to assist you in the choice of networks, in the determination of their characteristics, and to allow you to design your own. The formulae appearing at the head of fixed network sections include values of "K" which may be determined from this table.

INSTRUCTION

Note that the table covers values up to 20 db only. For higher values revert to the beginning of the table and move the decimal to the right one place for the "K", or Gain column, and one place to the left for the "L", or Loss column. For example, to find the value of "K" at 24.3 volts, locate the value of "K" at 4.3 volts; this is 1.641. Move the decimal to the right one point, and the value for 24.3 volts becomes K=16.41. It will be seen from this that the table repeats numerically every 20 db for decibel voltage

VOLTAGE RATIOS

Decibel Voltage	$\frac{1}{K}$ Loss	K Gain	Decibel Voltage	$\frac{1}{K}$ Loss	K Gain	Decibel Voltage	$\frac{1}{K}$ Loss	K Gain	Decibel Voltage	$\frac{1}{K}$ Loss	K Gain
.0	1.0000	1.000	5.0	.5623	1.778	10.0	.3162	3.162	15.0	.1778	5.623
.1	.9886	1.012	.1	.5559	1.799	.1	.3126	3.199	.1	.1758	5.689
.2	.9772	1.023	.2	.5495	1.820	.2	.3090	3.236	.2	.1738	5.754
.3	.9661	1.035	.3	.5433	1.841	.3	.3055	3.273	.3	.1718	5.821
.4	.9550	1.047	.4	.5370	1.862	.4	.3020	3.311	.4	.1698	5.888
.5	.9441	1.059	.5	.5309	1.884	.5	.2985	3.350	.5	.1679	5.957
.6	.9333	1.072	.6	.5248	1.905	.6	.2951	3.388	.6	.1660	6.026
.7	.9226	1.084	.7	.5188	1.928	.7	.2917	3.428	.7	.1641	6.095
.8	.9120	1.096	.8	.5129	1.950	.8	.2884	3.467	.8	.1622	6.166
.9	.9061	1.109	.9	.5070	1.972	.9	.2851	3.508	.9	.1603	6.237
1.0	.8913	1.122	6.0	.5012	1.995	11.0	.2818	3.548	16.0	.1585	6.310
.1	.8810	1.135	.1	.4955	2.018	.1	.2786	3.589	.1	.1567	6.383
.2	.8710	1.148	.2	.4898	2.042	.2	.2754	3.631	.2	.1549	6.457
.3	.8610	1.161	.3	.4842	2.065	.3	.2723	3.673	.3	.1531	6.531
.4	.8511	1.175	.4	.4786	2.089	.4	.2692	3.715	.4	.1514	6.607
.5	.8414	1.189	.5	.4732	2.113	.5	.2661	3.758	.5	.1496	6.683
.6	.8318	1.202	.6	.4677	2.138	.6	.2630	3.802	.6	.1479	6.761
.7	.8222	1.216	.7	.4624	2.163	.7	.2600	3.846	.7	.1462	6.839
.8	.8128	1.230	.8	.4571	2.188	.8	.2570	3.890	.8	.1445	6.918
.9	.8035	1.245	.9	.4519	2.213	.9	.2541	3.936	.9	.1429	6.998
2.0	.7943	1.259	7.0	.4467	2.239	12.0	.2512	3.981	17.0	.1413	7.079
.1	.7852	1.274	.1	.4416	2.265	.1	.2483	4.027	.1	.1396	7.161
.2	.7762	1.288	.2	.4365	2.291	.2	.2455	4.074	.2	.1380	7.244
.3	.7674	1.303	.3	.4315	2.317	.3	.2427	4.121	.3	.1365	7.328
.4	.7586	1.318	.4	.4266	2.344	.4	.2399	4.169	.4	.1349	7.413
.5	.7499	1.334	.5	.4217	2.371	.5	.2371	4.217	.5	.1334	7.499
.6	.7413	1.349	.6	.4169	2.399	.6	.2344	4.266	.6	.1318	7.586
.7	.7328	1.365	.7	.4121	2.427	.7	.2317	4.315	.7	.1303	7.674
.8	.7244	1.380	.8	.4074	2.455	.8	.2291	4.365	.8	.1288	7.762
.9	.7161	1.396	.9	.4027	2.483	.9	.2265	4.416	.9	.1274	7.852
3.0	.7079	1.413	8.0	.3981	2.512	13.0	.2239	4.467	18.0	.1259	7.943
.1	.6998	1.429	.1	.3936	2.541	.1	.2213	4.519	.1	.1245	8.035
.2	.6918	1.445	.2	.3890	2.570	.2	.2188	4.571	.2	.1230	8.128
.3	.6839	1.462	.3	.3846	2.600	.3	.2163	4.624	.3	.1216	8.222
.4	.6761	1.479	.4	.3802	2.630	.4	.2138	4.677	.4	.1202	8.318
.5	.6683	1.496	.5	.3758	2.661	.5	.2113	4.732	.5	.1189	8.414
.6	.6607	1.514	.6	.3715	2.692	.6	.2089	4.786	.6	.1175	8.511
.7	.6531	1.531	.7	.3673	2.723	.7	.2065	4.842	.7	.1161	8.610
.8	.6457	1.549	.8	.3631	2.754	.8	.2042	4.898	.8	.1148	8.710
.9	.6383	1.567	.9	.3589	2.786	.9	.2018	4.955	.9	.1135	8.811
4.0	.6310	1.585	9.0	.3548	2.818	14.0	.1995	5.012	19.0	.1122	8.913
.1	.6237	1.603	.1	.3508	2.851	.1	.1972	5.070	.1	.1109	9.016
.2	.6166	1.622	.2	.3467	2.884	.2	.1950	5.129	.2	.1096	9.120
.3	.6095	1.641	.3	.3428	2.917	.3	.1928	5.188	.3	.1084	9.226
.4	.6026	1.660	.4	.3388	2.951	.4	.1905	5.248	.4	.1072	9.333
.5	.5957	1.679	.5	.3350	2.985	.5	.1884	5.309	.5	.1059	9.441
.6	.5888	1.698	.6	.3311	3.020	.6	.1862	5.370	.6	.1047	9.550
.7	.5821	1.718	.7	.3273	3.055	.7	.1841	5.433	.7	.1035	9.661
.8	.5754	1.738	.8	.3236	3.090	.8	.1820	5.495	.8	.1023	9.772
.9	.5689	1.758	.9	.3199	3.126	.9	.1799	5.559	.9	.1012	9.886
									20.0	.1000	10.000

MIXER NETWORKS

Mixer Networks are employed to restore the original line impedance after paralleling various numbers of mixer circuits. Langevin Mixer Networks are available in Unbalanced "T" and Balanced "H" configurations. The popular and recommended form is the Unbalanced "T". Mixer Networks are stocked in any number of branches up to 16, and sustain steady sine wave tones up to + 30 dbm. Transient signals or program material have a safe limit in operation up to five times this power.

Mixing Networks are normally designed for the same input and output impedances. Under unusual circumstances it may be desirable to mix line inputs of several different impedances, or to provide an

input impedance which varies from the input lines. Other cases may demand added losses for input lines which operate at higher levels than the remainder of the lines to be mixed.

In cases of mixed impedances and varied losses, three courses are open to the designing engineer. One course is to refer to the table on page 69, "MATCHING AND MISMATCHING LOSSES", to see if the resulting levels will be satisfactory; if not, the second alternative is to order special networks from Langevin to your specification. The third alternative is to design the network from the data provided in this section and to construct it from such components as may be locally available.

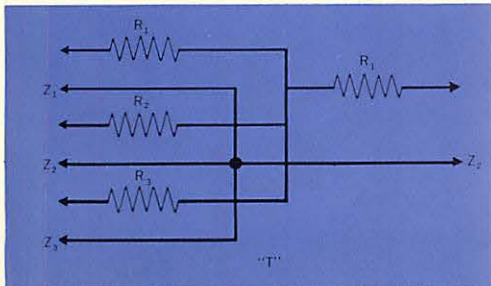

$$\frac{N-1}{N+1}Z = R_1$$

Where:

N = number of inputs
Z = impedance in ohms
R = resistance in ohms
 and
Z₁ input = **Z₂** output

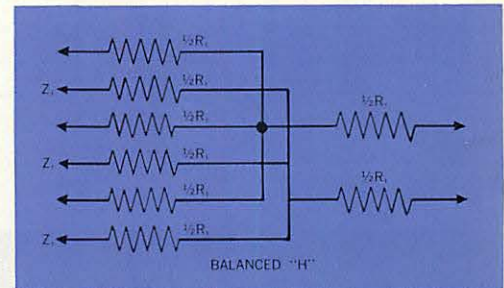

MODEL	NUMBER OF INPUTS	DB LOSS	CASE SIZE
FNT-2	2	6	A
FNT-3	3	9.5	
FNT-4	4	12	
FNT-5	5	14	B
FNT-6	6	15.6	
FNT-7	7	16.9	
FNT-8	8	18.1	
FNT-9	9	19.1	
FNT-10	10	20	
FNT-11	11	20.8	C
FNT-12	12	21.6	
FNT-13	13	22.3	
FNT-14	14	22.9	
FNT-15	15	23.5	
FNT-16	16	24.1	

MODEL	NUMBER OF INPUTS	DB LOSS	CASE SIZE
FNH-2	2	6	A
FNH-3	3	9.5	
FNH-4	4	12	
FNH-5	5	14	B
FNH-6	6	15.6	
FNH-7	7	16.9	
FNH-8	8	18.1	
FNH-9	9	19.1	
FNH-10	10	20	
FNH-11	11	20.8	C
FNH-12	12	21.6	
FNH-13	13	22.3	
FNH-14	14	22.9	
FNH-15	15	23.5	
FNH-16	16	24.1	

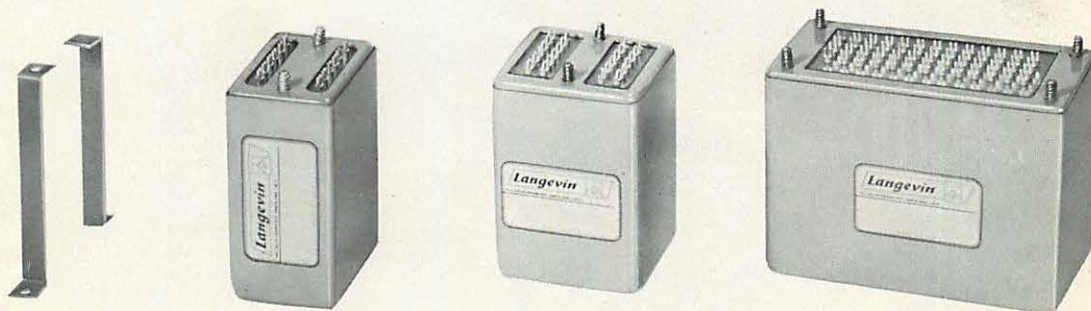

INTRODUCTION

The minimum loss for exactly matching lines of different impedances in the frequently used values is shown (p. 70). Infrequently it is desirable to match lines of impedances other than those in the shorter table, and also to mismatch lines where smaller losses are desired than the minimum matching loss caused by the matching pad. It is to be noted that this table applies equally to "T" or Balanced "H" circuits.

COLUMN 1, RATIO Z/Z

In this column select the figure which represents the ratio between the input and output impedances. If one is 600 ohms and the other 300 ohms the ratio is 2 to 1; in this case select the line showing the figure "2".

COLUMN 2, MINIMUM MATCHING LOSS

In this column the minimum loss in db will appear reading directly to the right of the impedance selected. In the case of a 600 ohm source and a 300 ohm load (or vice-versa) the impedance ratio of 2 shows a

minimum loss for the impedance pad of 7.665 db.

COLUMN 3, MISMATCH LOSS

In this column is shown the loss in db caused by "improper" termination. In reactive circuits the use of the term "improper" is appropriate for audio transmission work because of more or less frequency discrimination due to reflections caused by differing phase angles. But in a line whose elements are purely resistive a mismatched circuit may be proper indeed where the lowest possible loss is desired. Thus it will be seen in the case of a 600/300 ohm, 2.1 purely resistive mismatch the loss is .510 db versus the loss through the matching pad of 7.665 db.

For ratios not shown matching losses are found as follows:
Let R^2 = impedance ratio.

Let N = db loss.

For minimum loss, matching $N = 20 \log_{10} (R + \sqrt{R^2 - 1})$

For mismatch loss $N = 20 \log_{10} \left(\frac{R^2 + 1}{2R} \right)$

PAD LOSS TABLES

Note: Balanced Networks are derived by dividing all series arms by one-half and inserting them in both sides of the line.

Column 1 Ratio Z/Z	Column 2 Minimum Loss "T" Matching	Column 3 Impedance Mismatch Loss	Column 1 Ratio Z/Z	Column 2 Minimum Loss "T" Matching	Column 3 Impedance Mismatch Loss	Column 1 Ratio Z/Z	Column 2 Minimum Loss "T" Matching	Column 3 Impedance Mismatch Loss	Column 1 Ratio Z/Z	Column 2 Minimum Loss "T" Matching	Column 3 Impedance Mismatch Loss
1.0	0.	0.	6.0	13.41	3.090	12.0	16.63	5.470	32.0	21.00	9.320
.1	2.705	.00986	.1	13.48	3.155	.2	16.70	5.545	.5	21.07	9.360
.2	3.770	.03604	.2	13.57	3.208	.4	16.77	5.600	33.0	21.13	9.440
.3	4.548	.0778	.3	13.65	3.240	.6	16.84	5.650	.5	21.21	9.480
.4	5.180	.1223	.4	13.71	3.293	.8	16.92	5.700	34.0	21.28	9.560
.5	5.723	.172	.5	13.79	3.341	13.0	16.97	5.750	.5	21.34	9.600
.6	6.190	.240	.6	13.87	3.400	.2	17.03	5.820	35.0	21.40	9.660
.7	6.615	.308	.7	13.92	3.453	.4	17.12	5.875	.5	21.46	9.710
.8	6.990	.366	.8	14.00	3.490	.6	17.18	5.930	36.0	21.51	9.770
.9	7.340	.440	.9	14.07	3.540	.8	17.25	5.990	.5	21.57	9.840
2.0	7.665	.510	7.0	14.13	3.600	14.0	17.32	6.050	37.0	21.67	9.890
.1	7.955	.570	.1	14.20	3.630	.2	17.38	6.093	.5	21.73	9.940
.2	8.235	.660	.2	14.27	3.683	.4	17.43	6.150	38.0	21.77	10.00
.3	8.490	.732	.3	14.32	3.735	.6	17.50	6.205	.5	21.83	10.05
.4	8.740	.804	.4	14.40	3.778	.8	17.57	6.248	39.0	21.90	10.10
.5	8.970	.883	.5	14.46	3.810	.2	17.63	6.300	.5	21.93	10.17
.6	9.185	.962	.6	14.51	3.853	.4	17.78	6.420	40.0	21.97	10.21
.7	9.388	1.030	.7	14.58	3.908	.6	17.92	6.550	.5	22.07	10.28
.8	9.580	1.088	.8	14.65	3.948	16.0	17.92	6.550	41.0	22.11	10.31
.9	9.775	1.168	.9	14.70	3.985	.5	18.05	6.666	.5	22.15	10.37
3.0	9.960	1.244	8.0	14.77	4.025	17.0	18.18	6.790	42.0	22.20	10.42
.1	10.01	1.312	.1	14.83	4.085	.5	18.32	6.890	.5	22.26	10.47
.2	10.30	1.387	.2	14.88	4.105	18.0	18.43	7.010	43.0	22.32	10.51
.3	10.47	1.468	.3	14.92	4.160	.5	18.57	7.110	.5	22.36	10.57
.4	10.62	1.527	.4	14.97	4.200	19.0	18.68	7.220	44.0	22.40	10.60
.5	10.76	1.598	.5	15.05	4.255	.5	18.80	7.340	.5	22.47	10.66
.6	10.90	1.670	.6	15.10	4.285	20.0	18.92	7.425	45.0	22.51	10.69
.7	11.04	1.733	.7	15.15	4.320	.5	19.02	7.510	.5	22.54	10.77
.8	11.18	1.807	.8	15.20	4.360	21.0	19.13	7.600	46.0	22.60	10.81
.9	11.31	1.868	.9	15.25	4.400	.5	19.22	7.700	.5	22.67	10.83
4.0	11.43	1.938	9.0	15.30	4.440	22.0	19.33	7.795	47.0	22.70	10.88
.1	11.56	2.000	.1	15.36	4.480	.5	19.42	7.895	.5	22.73	10.93
.2	11.68	2.070	.2	15.40	4.510	23.0	19.52	7.980	48.0	22.77	10.97
.3	11.80	2.130	.3	15.44	4.550	.5	19.62	8.055	.5	22.83	11.02
.4	11.88	2.200	.4	15.50	4.600	24.0	19.73	8.140	49.0	22.90	11.05
.5	12.02	2.266	.5	15.54	4.640	.5	19.83	8.213	.5	22.93	11.10
.6	12.13	2.318	.6	15.60	4.660	25.0	19.91	8.300	50.0	22.96	11.14
.7	12.23	2.391	.7	15.67	4.700	.5	20.00	8.380	55.0	23.38	11.55
.8	12.33	2.431	.8	15.70	4.740	26.0	20.10	8.460	60.0	23.56	11.83
.9	12.43	2.490	.9	15.74	4.780	.5	20.17	8.540	65.0	24.11	12.23
5.0	12.53	2.550	10.0	15.79	4.800	27.0	20.24	8.630	70.0	24.44	12.55
.1	12.63	2.607	.1	15.87	4.880	.5	20.30	8.680	75.0	24.74	12.84
.2	12.72	2.667	.2	15.95	4.950	28.0	20.40	8.760	80.0	25.02	12.97
.3	12.83	2.725	.3	16.05	5.010	.5	20.49	8.845	85.0	25.12	13.37
.4	12.91	2.778	.4	16.13	5.090	29.0	20.55	8.920	90.0	25.53	13.62
.5	13.00	2.837	.5	16.22	5.150	.5	20.63	8.970	95.0	25.77	13.81
.6	13.08	2.893	.6	16.31	5.220	30.0	20.70	9.040	100.0	25.99	14.07
.7	13.17	2.932	.7	16.38	5.290	.5	20.78	9.095			
.8	13.26	2.997	.8	16.47	5.340	31.0	20.87	9.160			
.9	13.33	3.050	.9	16.53	5.410	.5	20.94	9.250			

MINIMUM LOSS MATCHING PADS

$$Z_1 > Z_2$$

$$A = \sqrt{Z_1(Z_1 - Z_2)}$$

$$B = \frac{Z_1 Z_2}{A}$$

$$C = 0$$

$$\text{DB Loss} = 20 \log_{10} \frac{A+B}{B}$$

This is the table referred to on the preceding page on which appears the PAD LOSS TABLE. Commonly used values of input and output impedances are shown, and the price for each is the same for matching a low impedance to a higher impedance, or vice-versa. Note that these are actually "T" pads with the C series arm having a value of zero.

Many occasions arise when the minimum loss caused by a matching pad is too high. For instance it may be necessary to match a 150 ohm line to a 600 ohm line with the loss shown as 11.43 db. The solution to this problem is to use the Langevin Model TF-602-C line-to-line matching transformers which reduce the loss to approximately 1 db.

ORDERING INFORMATION

Specify the Model number of the Minimum Loss Matching Pad, and designate the two impedance values required.

Model FNML-100 Minimum Loss Matching Pad. (Specify impedances in and out) Mounted in Case A, dimensions 1 7/32" wide by 2 1/2" high by 1 3/4" deep.

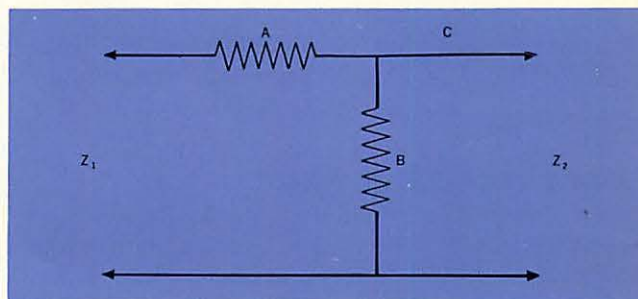
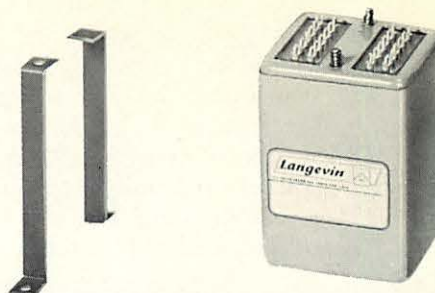

MINIMUM LOSS MATCHING PADS — LOSS IN DB

FROM	TO	30	50	125	150	200	250	500	600
30		0	6.47	11.63	12.53	13.91	14.95	18.11	18.92
50		6.47	0	8.97	9.96	11.44	12.54	15.79	16.63
125		11.63	8.97	0	3.76	6.19	7.65	11.43	12.33
150		12.53	8.96	3.76	0	4.74	6.47	10.52	11.43
200		13.91	11.44	6.19	4.74	0	4.18	8.96	9.95
250		14.95	12.54	7.65	6.47	4.18	0	7.65	8.73
500		18.11	15.79	11.43	10.52	8.96	7.65	0	3.76
600		18.92	16.63	12.33	11.43	9.95	8.73	3.76	0

FIXED LOSS PADS

If we were to consider an amplifier as a "package" of gain in a transmission circuit, it would follow that the fixed gain must be offset by a fixed loss in order to achieve the desired gain in db from the package, except in cases where the amplifier has exactly the gain required. These are required so that equipments in succeeding sections of the line can be safeguarded from over-load; this holds true particularly in the case of the input stage of a following amplifier. This explains briefly the use of fixed loss pads, and serves as an explanation of why only 600 ohm impedances are supplied unless otherwise specified on the user's order.

ORDERING INFORMATION

When ordering the Model FN-100 Fixed Loss Pads specify number of db attenuation required. These pads are available in any loss up to 60 db. Stock impedance is 600 ohms; specify impedances other than 600 ohms if desired.

Model FN-100-T Fixed Loss Pad, () db attenuation, "T" Circuit, size 1 7/32" wide by 2 1/2" high by 1 3/4" deep, Case Size A. Specify if for other than 600 ohm impedance.

Weight, net 1/4 lbs., 1/2 lbs. shpg.

Model FN-100-H Fixed Loss Pad, () db attenuation, same as above, but balanced "H" circuit.

Weight, net 1/4 lbs., 1/2 lbs. shpg.

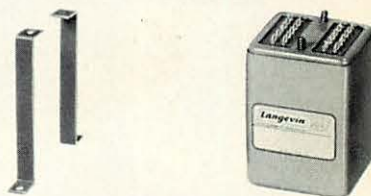

$$Z_1 = Z_2$$

$$\left(\frac{K-1}{K+1}\right) Z = A$$

$$\left(\frac{K}{K^2-1}\right) Z = B$$

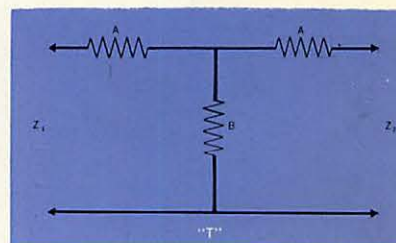

$$Z_1 = Z_2$$

$$(K-1) Z = A$$

$$\left(\frac{1}{K-1}\right) Z = B$$

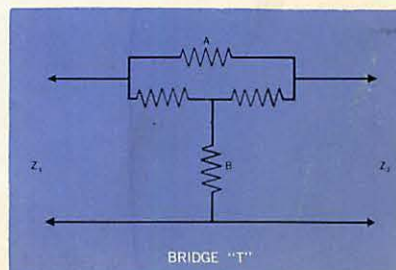

\$5

VU METER MULTIPLIERS

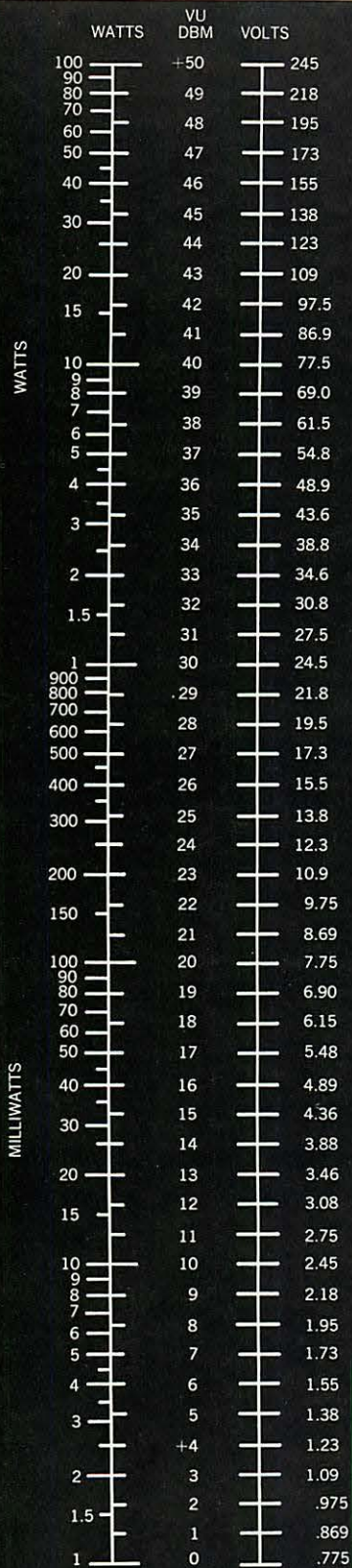

VOLTS MEASURED ON 600 Ω LINE.
FOR OTHER IMPEDANCES (Z):

$$E_v = V \sqrt{\frac{Z}{600}}$$

EXAMPLE: FOR 150 OHMS AT +4 VU

$$E = 1.23 \sqrt{\frac{150}{600}} = .615 \text{ VOLTS}$$

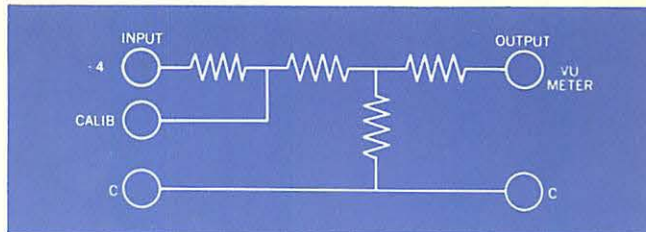

VU Meters use a total external series resistance of 3600 ohms to deliver a reading of "0" VU when a 1000 cps sine wave of 1.228 volts is applied. This represents 4 db above 1 milliwatt in a 600 ohm line, the standard level used in most transmission work. It is desirable at times to extend this range either by a variable rotary range extending network (covered in previous pages under Rotary Attenuators) or to extend the range with a Fixed Multiplier Pad. Noted in the listings below is a calibrating adjust pad in .1 db steps for fixed matching of meters and for use in meter circuits of measuring equipment such as Gain Sets.

ALL INPUTS ARE APPROPRIATELY TAPPED SO THAT VR-111 VARIABLE WIRE WOUND CALIBRATING RESISTOR MAY BE EMPLOYED IF DESIRED.

TAPPED "T" MULTIPLIERS

MODEL	TAPS	CASE SIZE
FTM-4	1 DB — .1 DB Steps	A
FTM-12		

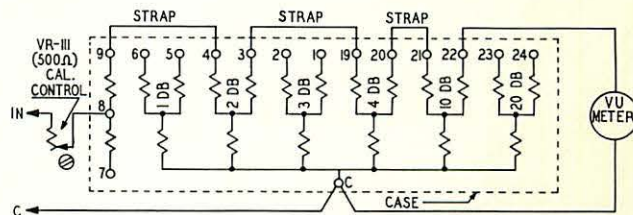

FOR METER BRIDGING

INDIVIDUAL MULTIPLIERS

"T" CIRCUIT

MODEL	EXTENSION IN DB		CASE SIZE
	AT 600 OHMS	AT 16 OHMS	
FNVU-4	+4	+20	A
FNVU-6	+6	+22	
FNVU-8	+8	+24	
FNVU-10	+10	+26	
FNVU-12	+12	+28	
FNVU-14	+14	+30	
FNVU-16	+16	+32	
FNVU-18	+18	+34	
FNVU-20	+20	+36	
FNVU-22	+22	+38	
FNVU-24	+24	+40	
FNVU-26	+26	+42	
FNVU-28	+28	+44	
FNVU-30	1 Watt +30	+46	
FNVU-40	10 Watts +40	+56	C
FNVU-44	25 Watts +44	+60	
FNVU-47	50 Watts +47		
FNVU-50	100 Watts +50		

BRIDGING PADS

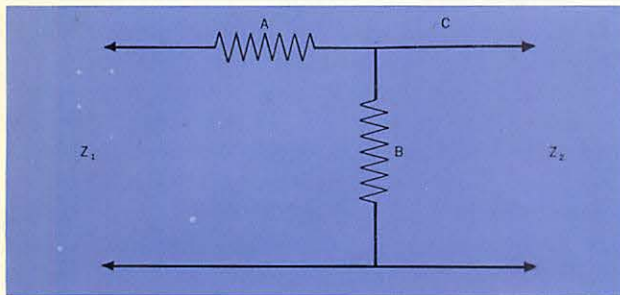
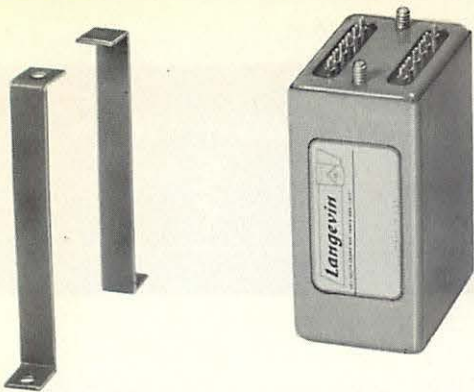

The figure illustrates the usual bridging pad. This pad is of the "L" configuration but may actually be treated on as a "T" pad with a series arm of zero ohms on the output. This pad is used to present a high impedance input to a 600 ohm line output, thus leaving the line virtually unaffected by the increased load. Typical employment would be between a high gain power amplifier and the bridging bus.

Balanced networks are also available, however infrequently they may be used. They are derived simply by halving the series arms and inserting them in both sides of the line and also by allowing the "B" or shunt arm to be center tapped for the common or ground connection. If a balanced network is desired, specify "Balanced" after the model number.

BRIDGING PADS

MODEL	LOSS	IMPEDANCES	CASE SIZE
FNB-20	20 DB	3000 OHMS IN 600 OHMS OUT	A
FNB-30	30 DB	9500 OHMS IN 600 OHMS OUT	
FNB-40	40 DB	9500 OHMS IN 600 OHMS OUT	

HOW TO ORDER SPECIAL NETWORKS

To order networks other than those listed on these pages, specify the following data:

CIRCUIT _____

1. "T" CIRCUIT OR BALANCED "H"

Hold in mind that twice as many components are required for the balanced "H" and that this calls for *double* the space of "T" configurations.

INPUTS AND OUTPUTS _____

2. NUMBER OF INPUT CIRCUITS AND OUTPUT CIRCUITS

Each input and output circuit has separate ground to preserve balance and to prevent crosstalk.

IMPEDANCES _____

3. IMPEDANCE OF INPUT AND OUTPUT CIRCUITS

It is possible to order different impedances on various inputs and outputs in the same network.

LOSS _____

4. SPECIFY LOSS OR LOSSES DESIRED

It is possible to order various losses on different inputs, provided that they are above the minimum losses required by the circuit ratios concerned. Refer to **MIMUM LOSS TABLE**.

SIZE _____

5. SIZE OF CONTAINER

Size of container depends on the number of resistive elements necessary and space for the terminals. Refer to drawings on page 66.

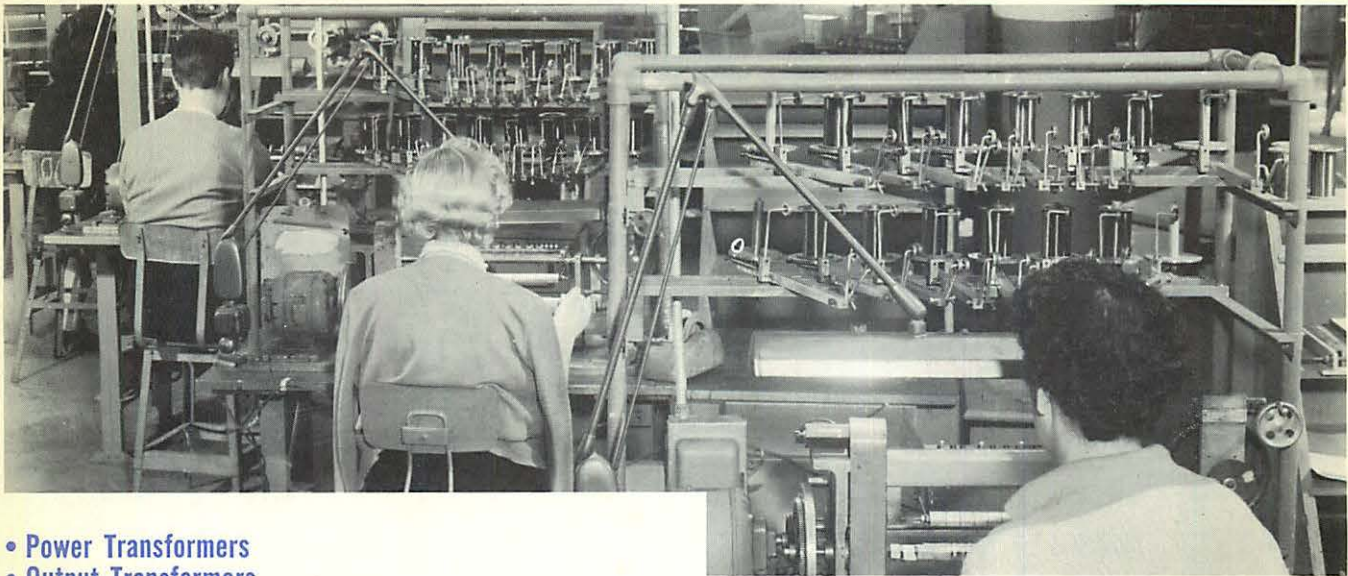

- Power Transformers
- Output Transformers
- Filter Reactors
- Input Transformers
- Line Isolation and Bridging Transformers
- Line to Voice-Coil Transformers

Langevin makes available all the transformers and reactors used in its own equipments, along with line-to-line transformers, bridging transformers and line-to-voice coil units. Thus, a complete service is offered to its customers who desire to construct specialized amplifiers or to match existing Langevin components to other equipment.

(In Inches)

TYPE	A	B	C	D	E
0A	1 ⁵⁵ / ₆₄	1 ⁴¹ / ₆₄	3	Single Stud Mounting	1 ¹ / ₁₆
1-A	2 ⁷ / ₁₆	2	2 ⁷ / ₈	5/8	1 ³ / ₁₆
2-A	2 ³ / ₄	2 ³ / ₈	3 ³ / ₁₆	3/4	1 ⁵ / ₁₆
3-A	3 ¹ / ₁₆	2 ¹ / ₁₆	3 ⁵ / ₈	7/8	1 ¹ / ₁₆
4-A	4 ¹ / ₂	3	3 ⁷ / ₈	1	1 ³ / ₄
5-A	5	3 ⁷ / ₈	5	1 ⁷ / ₁₆	2
5 ¹ / ₂ -A	5	4 ¹ / ₂	5	1 ¹³ / ₁₆	2
6A	5	5 ¹ / ₈	5	2 ¹ / ₁₆	2

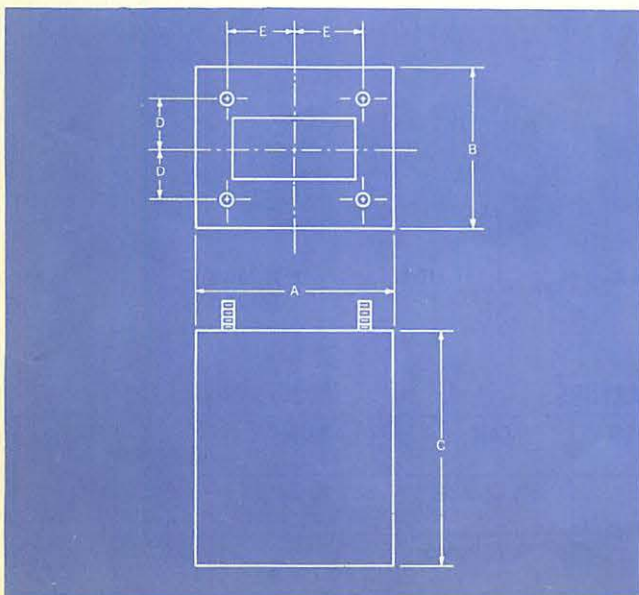

DESIGN PHILOSOPHY

Langevin exploits the latest techniques in fabrication and employs only high quality materials. Coupled with Langevin's philosophy of exceeding long component life, all structures are oversize to provide 300 and 400 percent overload capacity along with cool operation.

HIGH TEMPERATURE WIRE EMPLOYED

Langevin coils employ Alkanex wire. This wire has the ability to withstand operation at 180° centigrade in excess of 80,000 hours.

CORE MATERIAL

The proper core material is always selected to suit the job; while usual practice on a particular coil may be to stack 2 to 1, Langevin stacks 1 to 1 to guarantee best copper to core ratio for widest pass band. Closed cores are employed with minimum gaps to confine fields; hypersil loops are used to maintain copper to core ratios when performance dictates. All cores are properly grounded.

WINDINGS

Input coils employ multiple section interleaved windings to reduce leakage reactance and distributed capacitance. Semi-toroidal construction confines pick-up field for low hum and conserves space.

VARNISHES AND POTTING COMPOUNDS

Varnishes are specially selected for mechanical as well as dielectric strength. Potting compounds are applied with vacuum impregnation with generous use being made of latest epoxy types for secure seal and long life.

HUM-BUCKING CONSTRUCTION

Highly conductive outer cases, multiple permalloy and copper shield nests, semi-toroid design and hum-bucking coil configuration all serve to make Langevin coils ideal for use in quality transmission circuits.

DISTORTION PRODUCTS

Advanced design, good materials, care in manufacture and test give low distortion without the need for excessive and consequently unstable feed-back loops.

TRANSFORMERS

POWER TRANSFORMERS

MODEL	PRIMARY VOLTAGE RANGE 50/60 CYCLES	PLATE WINDINGS	FILAMENT WINDINGS	CASE NO. OR SIZE* WIDTH X DEPTH X HEIGHT	WEIGHT
TF-100-B	105-125	430-0-430, 300 MA	5V-6A 6.3V CT-8A	SPECIAL 5A 5 ¹ / ₁₆ HIGH	NET 16 lbs SHPG 18 lbs
TF-101-E	105-125	430-395-0-395-430 140 MA	5V-3A 6.3V CT-5A	5A	NET 11 ¹ / ₂ lbs SHPG 13 lbs
TF-102-A	105-125	260-230-0-230-260 75 MA	5V-3A 6.3V CT-8A	4A	NET 5 ³ / ₄ lbs SHPG 6 ¹ / ₂ lbs
TF-105-B	100-130 200-260	60-380-395-410-425	NONE	5 ¹ / ₂ A	NET 12 lbs SHPG 15 lbs
TF-106-B	100-130 200-260	NONE	6.3V CT-8A	4A	NET 5 ³ / ₄ lbs SHPG 6 ¹ / ₂ lbs
TF-107-C	105-125	0-40-420-430-440-450 210 MA	NONE	5A	NET 11 ¹ / ₂ lbs SHPG 13 lbs
TF-108-C	110-125	350-0-350, 100 MA	5V-2A 6.3V-2.3A	3 ¹ / ₈ x 3 ¹ / ₈ x 3	NET 4 lbs SHPG 5 lbs
TF-111-B	105-125 210-250	NONE	6.3-8A	3A	NET 3 ¹ / ₂ lbs SHPG 4 ¹ / ₂ lbs
TF-112-B	105-125	440-400-0-400-440 110 MA	5V-2A 6.3V-4.5A	3 ¹ / ₁₆ x 3 ¹ / ₈ x 3 ⁷ / ₈	NET 6 ¹ / ₂ lbs SHPG 7 ³ / ₄ lbs
TF-116-A	105-125	SECONDARY WINDING		3 ¹ / ₂ x 3 ³ / ₄ x 4	NET 4 ¹ / ₂ lbs SHPG 5 ¹ / ₂ lbs
TF-117-A	105-125	50 (WITH 3 AGING TAPS)		7 ¹ / ₂ x 5 x 7 ¹ / ₂	NET 16 lbs SHPG 18 lbs
TF-118-A	105-125 210-250	350-315-0-315-350 235 MA	5V-5A	4 x 3 ¹ / ₁₆ x 2 ⁷ / ₈	NET 5 ¹ / ₂ lbs SHPG 6 ¹ / ₂ lbs
TF-119-A	105-125	NONE	6.3V-6.5A C.T.	3 ¹ / ₄ x 3 x 2 ⁷ / ₈	NET 3 lbs SHPG 4 lbs
TF-120-C (HUMBUCKING)	105-125	425-375-0-375-425 125 MA	5V-2A 6.3V-3A C.T.	3 ⁵ / ₈ x 2 ¹ / ₃₂ x 2 ¹ / ₁₆	NET 3 lbs SHPG 4 lbs
TF-120-B	105-125	425-375-0-375-425 125 MA	5V-2A 6.3V-3A C.T.	3 ⁵ / ₈ x 2 ¹ / ₃₂ x 2 ¹ / ₁₆	NET 3 lbs SHPG 4 lbs



TF-100-B



TF-101-E
TF-107-C

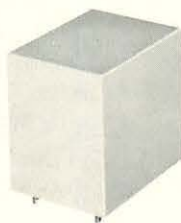

TF-102-A
TF-106-B



TF-105-B



TF-108-C



TF-111-B



TF-116-A
TF-902-A



TF-112-B

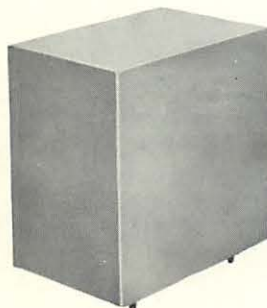

TF-117-A



TF-118-A



TF-119-A



TF-120-B
TF-120-C

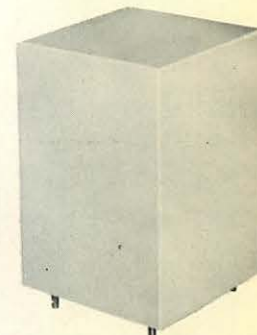

TF-901-A

SATURABLE REACTORS

MODEL	DC CONTROL WINDING	AC WINDING	INSULATION TEST	CASE	WEIGHT
TF-901-A	10A	500VA	1250	5 ¹ / ₂ x 5 x 7 ¹ / ₂	NET 20 lbs SHPG 23 ¹ / ₂ lbs
TF-902-A	3A	175VA	1000	3 ¹ / ₄ x 2 ¹ / ₁₆ x 5	NET 6 lbs SHPG 7 ¹ / ₂ lbs

TRANSFORMERS

OUTPUT TRANSFORMERS

MODEL	PRIMARY IMPEDANCE	SECONDARY IMPEDANCE	OPERATING LEVEL	CASE NO. OR SIZE WIDTH X DEPTH X HEIGHT	WEIGHT
TF-129-A	20,000 OHMS	600/250	+26 DBM	1 3/4 x 1 1/4 x 2	NET 3/4 lb SHPG 1 1/4 lbs
TF-308-A	4000 OHMS	600/150	1 WATT	3 A (Electro-Magnetic Shielding)	NET 3 1/2 lbs SHPG 4 1/2 lbs
TF-311-C (HUMBUCKING CONSTRUCTION)	10,000 OHMS Plate to Plate C.T.	600/150 Tertiary Feedback Winding	10 WATTS	3 A (Electro-Magnetic Shielding)	NET 3 1/2 lbs SHPG 4 1/2 lbs
TF-313-A	16,000 OHMS	600/150 Tertiary Feedback Winding	+20 DBM	2 1/8 x 1 3/4 x 3 1/4 (Electro-Magnetic Shielding)	NET 1 lb SHPG 1 1/2 lbs
TF-314-A	16,000 OHMS	600/150	+16 DBM	3 A (Electro-Magnetic Shielding)	NET 3 1/2 lbs SHPG 4 1/2 lbs
TF-316-A	3700 OHMS Plate to Plate C.T.	600/150/32/16/8/2 Tertiary Feedback Winding	50 WATTS	6 x 4 1/2 x 5 1/8	NET 19 lbs SHPG 22 lbs
TF-317-A	6800 OHMS Plate to Plate C.T.	600/150/32/16/8/2 Tertiary Feedback Winding	20 WATTS	4 A	NET 5 3/4 lbs SHPG 6 1/2 lbs
TF-320-C	10,000 OHMS Plate to Plate C.T.	600/6.4/3.2 Tertiary Feedback Winding	10 WATTS	3 x 2 1/2 x 2 1/8	NET 3 1/2 lbs SHPG 4 1/2 lbs
TF-321-B	16,000 OHMS	150/150 Tertiary Feedback Winding	+18 DBM	2 x 1 3/8 x 1 1/8	NET 1 lb SHPG 1 1/2 lbs
TF-322-B	10,000 OHMS Plate to Plate C.T.	600/150 Tertiary Feedback Winding	+40 DBM	2 1/2 x 2 1/8 x 2 3/8	NET 2 1/2 lbs SHPG 3 lbs

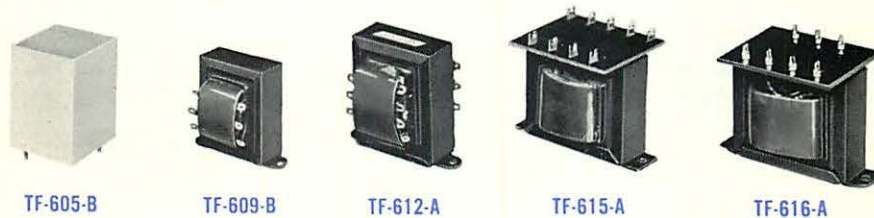

LINE TO VOICE COIL TRANSFORMERS

MODEL	PRIMARY IMPEDANCE (OHMS)	SECONDARY IMPEDANCE (OHMS)	INSERTION LOSS AT 1000 CYCLES	FREQUENCY RESPONSE	MAXIMUM OPERATING LEVEL	CASE NO. OR SIZE HEIGHT-MTG CTRS.	WEIGHT
TF-605-B	250/500/750/1000	16	.65 db	± 1 db from 50 to 15,000 cycles	20 WATTS	3 A	NET 3 1/2 lbs SHPG 4 1/2 lbs
TF-609-B	500/1000/1500/2000/3000/3500/4000/6000/8000	3.2/6.5	.7 db	± 1 db from 50 to 10,000 cycles	5 WATTS	Channel Construction 2 3/4 2 1/8	NET 1 3/4 lbs SHPG 2 1/4 lbs
TF-612-A	1000 to 128,000 (5 watts to 10 milliwatts in 3 db steps)	3.2/6.5	.5 db	± 1 db from 50 to 10,000 cycles	5 WATTS	Channel Construction 3 1/8 3 1/8	NET 2 1/2 lbs SHPG 3 1/2 lbs
TF-615-A	1000/1500/2000/2500/3000/4000/750/500	6-8	.7 db	± 1 db from 50 to 10,000 cycles	10 WATTS	Channel Construction 3 1/8 3 1/8	NET 2 1/4 lbs SHPG 3 1/2 lbs
TF-616-A	37.5/150/600	6.5/13	.5 db	± 5 db from 50 to 15,000 cycles	10 WATTS	Channel Construction 2 3/4 3 1/8	NET 2 1/4 lbs SHPG 3 lbs

TRANSFORMERS

INPUT TRANSFORMERS

MODEL	SOURCE IMPEDANCE (OHMS)	SECONDARY IMPEDANCE (OHMS)	MAXIMUM OPERATING LEVEL (DBM)	REMARKS	CASE NO. OR SIZE WIDTH x DEPTH x HEIGHT	WEIGHT
TF-132-B	600	60,000 to Push-Pull Grids	0	Electromagnetic Shield	1¼ x 1 x 1½	Net ¼ lb. Shpg ½ lb.
					CASE NO. OR SIZE DIAMETER—HEIGHT	
TF-400-D	600 and bridging (15,000)	60,000 to Single Grid	+10	Electromagnetic Shield	1⅜ 1⅜	Net ½ lb. Shpg ¾ lb.
TF-401-B	30/250/600	30,000 Single or Push-Pull Grids C.T.	+10	Electromagnetic Shield	1⅜ 1⅜	Net ½ lb. Shpg ¾ lb.
TF-402-B	30/120 nominal	50,000 to Single Grid	+10	Electromagnetic Shield working range of 120 ohm tap, 60 to 250 ohms	1⅜ 1⅜	Net ½ lb. Shpg ¾ lb.
TF-408-A	600/150 C.T. 37.5/340	65,000 Single or Push-Pull Grids C.T.	+10	Magnetic Shield, also Electrostatic Shield brought out for external connection	1⅜ 1⅜	Net ½ lb. Shpg ¾ lb.
TF-408-B	600/150 C.T. 37.5/340	65,000 Single or Push-Pull Grids C.T.	+10	Triple Magnetic Shielding, also Electrostatic Shield brought out for external connection	0A	Net 1 lb. Shpg 1½ lbs.
TF-408-D	600/340 150/37.5	65,000 to Single Grid	+10	Electromagnetic Shield, also Electrostatic Shield brought out for external connection	1½ 2½	Net ½ lb. Shpg ¾ lb.
TF-412-B	150/600 5000/20,000	60,000 to Single Grid	+10	Magnetic Shield	1⅜ 1⅜	Net ½ lb. Shpg ¾ lb.
TF-413-A	150/600 C.T. 340/37.5	50,000 to Single Grid	+10	Electromagnetic Shield, also Electrostatic Shield brought out for external connection	1½ 2½	Net ¾ lb. Shpg 1¼ lbs.



TF-132-B



TF-400-D
TF-401-B
TF-402-B
TF-408-A
TF-412-B



TF-408-B



TF-408-D



TF-413-A

TRANSFORMERS USED IN LANGEVIN AMPLIFIERS AND POWERS SUPPLIES

AMPLIFIERS-AM-	OUTPUT	POWER	INPUT	CHOKE
101-D	TF-316-A	TF-100-B	TF-400-D	TF-200-B
102 BASIC	TF-308-A			TF-201-A
116-B	TF-313-A		TF-408-B	
117-A	TF-311-C		TF-408-A	
128-X BASIC	TF-317-A	TF-101-E		
138S BASIC	TF-320-C	TF-108-C		
5116	TF-321-B		TF-413-A	
5116-B	TF-129-A		TF-132-B	
5117	TF-322-B		TF-408-D	
5301	TF-322-B		TF-132-B	

INPUT PANELS-INP-

A	TF-400-D
B	TF-402-B
G	TF-408-A
M	TF-412-B
Q	TF-408-A
R	TF-408-A

POWER SUPPLIES-PS-	POWER	CHOKE	FILAMENT	SAT. REACT.
201-B	TF-102-A	TF-201-A TF-204-A		
205-B	TF-105-B	TF-211-A (2) TF-212-A	TF-106-B (2)	
206-B	TF-107-C	TF-215-A	TF-111-B	
208-A	TF-112-B	TF-216-A		
210-A	TF-105-B	TF-211-A (2)	TF-106-B (2)	
211-B	TF-116-A	TF-218-A		TF-902-A
212-B	TF-117-A	TF-217-A		TF-901-A
5206	TF-118-A	TF-219-A (2)	TF-119-A	
5208-A	TF-120-B OR TF-120-C (Humbucking)	TF-220-A		

TRANSFORMERS

FILTER REACTORS

MODEL	INDUCTANCE	D.C. RATING FOR STATED INDUCTANCE	D.C. RESISTANCE	INSULATION TEST VOLTAGE	CASE NO. OR SIZE WIDTH X DEPTH X HEIGHT	WEIGHT NET
TF-200-B	6 HY	280 MA	100 OHMS	1500	4 A	NET 5 $\frac{3}{4}$ lbs SHPG 7 lbs
TF-201-A	30 HY	30 MA	800 OHMS	1000	1 A	NET 1 $\frac{3}{4}$ lbs SHPG 2 $\frac{1}{4}$ lbs
TF-202-A	5 $\frac{1}{2}$ HY	140 MA	200 OHMS	1000	2 $\frac{3}{8}$ x 2 $\frac{3}{8}$ x 2	NET 2 lbs SHPG 2 $\frac{3}{4}$ lbs
TF-204-A	12 HY	80 MA	250 OHMS	1500	2 A	NET 2 $\frac{3}{4}$ lbs SHPG 4 $\frac{1}{2}$ lbs
TF-205-A	10 HY	140 MA	200 OHMS	1500	3 A	NET 3 $\frac{1}{2}$ lbs SHPG 4 $\frac{1}{2}$ lbs
TF-211-A	1 $\frac{3}{4}$ HY	425 MA	27 OHMS	1500	4 A	NET 5 $\frac{3}{4}$ lbs SHPG 6 $\frac{1}{2}$ lbs
TF-212-A	18 HY	150 MA	230 OHMS	1250	4 A	NET 5 $\frac{3}{4}$ lbs SHPG 6 $\frac{1}{2}$ lbs
TF-213-A	4 $\frac{1}{2}$ HY	210 MA	100 OHMS	1500	3 A	NET 3 $\frac{1}{2}$ lbs SHPG 4 $\frac{1}{2}$ lbs
TF-215-A (DUAL CHOKE)	4 HY 4 HY	210 MA 210 MA	70 OHMS 70 OHMS	1500 1500	SPECIAL 3 A 5	NET 5 $\frac{1}{2}$ lbs SHPG 5 $\frac{3}{4}$ lbs
TF-216-A (DUAL CHOKE)	12 HY 12 HY	.124 A .124 A	182 OHMS 182 OHMS	1000 1000	2 $\frac{3}{8}$ x 2 $\frac{3}{8}$ x 5	NET 6 lbs SHPG 7 lbs
TF-217-A	.043 HY	2.A	.017 OHMS	1250	5 $\frac{1}{2}$ x 5 x 7 $\frac{1}{2}$	NET 23 lbs SHPG 26 lbs
TF-218-A	.060 HY	2.A	.50 OHMS	1000	3 $\frac{1}{4}$ x 3 $\frac{3}{8}$ x 4	NET 5 $\frac{1}{2}$ lbs SHPG 6 $\frac{1}{2}$ lbs.
TF-219-A	4 HY	.235 ADC	100 OHMS	1500	3 $\frac{1}{4}$ x 3 x 2 $\frac{3}{8}$	NET 3 $\frac{1}{2}$ lbs SHPG 4 $\frac{1}{2}$ lbs
TF-220-A (DUAL CHOKE)	5 HY 5 HY	.125 ADC .125 ADC	180 OHMS 180 OHMS	1000 1000	4 $\frac{1}{8}$ x 1 $\frac{1}{4}$ x 2 $\frac{3}{8}$	NET 2 lbs SHPG 2 $\frac{1}{2}$ lbs

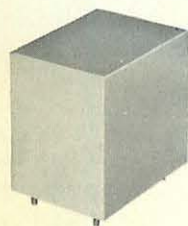

TF-200-B
TF-211-A
TF-212-A



TF-201-A



TF-202-A



TF-204-A



TF-205-A
TF-213-A



TF-215-A



TF-216-A



TF-602-C
TF-606-A
TF-607-A

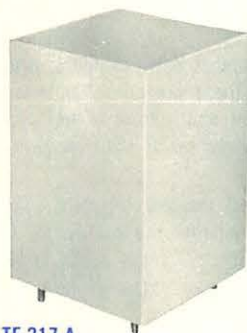

TF-217-A



TF-218-A



TF-219-A



TF-220-A

LINE ISOLATION AND BRIDGING TRANSFORMERS

MODEL	PRIMARY IMPEDANCE (OHMS)	SECONDARY IMPEDANCE (OHMS)	INSERTION LOSS AT 1000 CYCLES	FREQUENCY RESPONSE	MAXIMUM OPERATING LEVEL	CASE SIZE	WEIGHT
TF-602-C (Balanced Line and Isolation)	150/600 C.T. (Hum-Bucking Construction)	150/600 C.T.	1.6 db	$\pm .5$ db from 20 to 20,000 cycles	+18 DBM	2 A	NET 2 $\frac{3}{4}$ lbs SHPG 3 $\frac{1}{2}$ lbs
TF-606-A (BRIDGING)	48,000/12,000 (Hum-Bucking Construction—One Magnetic Shield)	600/150	Bridging loss: 24 db	$\pm .5$ db from 30 to 20,000 cycles	Bridge 600 OHM Line + 40 DBM	2 A	NET 2 $\frac{3}{4}$ lbs SHPG 3 $\frac{1}{2}$ lbs
TF-607-A (BRIDGING)	20,000/5,000	600/150 C.T.	Bridging loss: 18 db	$\pm .3$ db from 50 to 15,000 cycles	Bridge 600 OHM Line + 39 DBM	2 A	NET 2 $\frac{3}{4}$ lbs SHPG 3 $\frac{1}{2}$ lbs

FREE TECHNICAL SERVICE

As a service to users of Langevin equipment, free recommendations on components, layout and transmission techniques are offered.

In this regard Langevin will make preliminary suggestions in the form of block schematics to satisfy customer performance requirements listing appropriate Langevin components along with approximate costs of the total system. Since only general layout sketches and suggestions

are offered by Langevin, the execution of actual construction drawings is left to the customer. Recommended cabling and grounding practices are shown on pages 20 and 21.

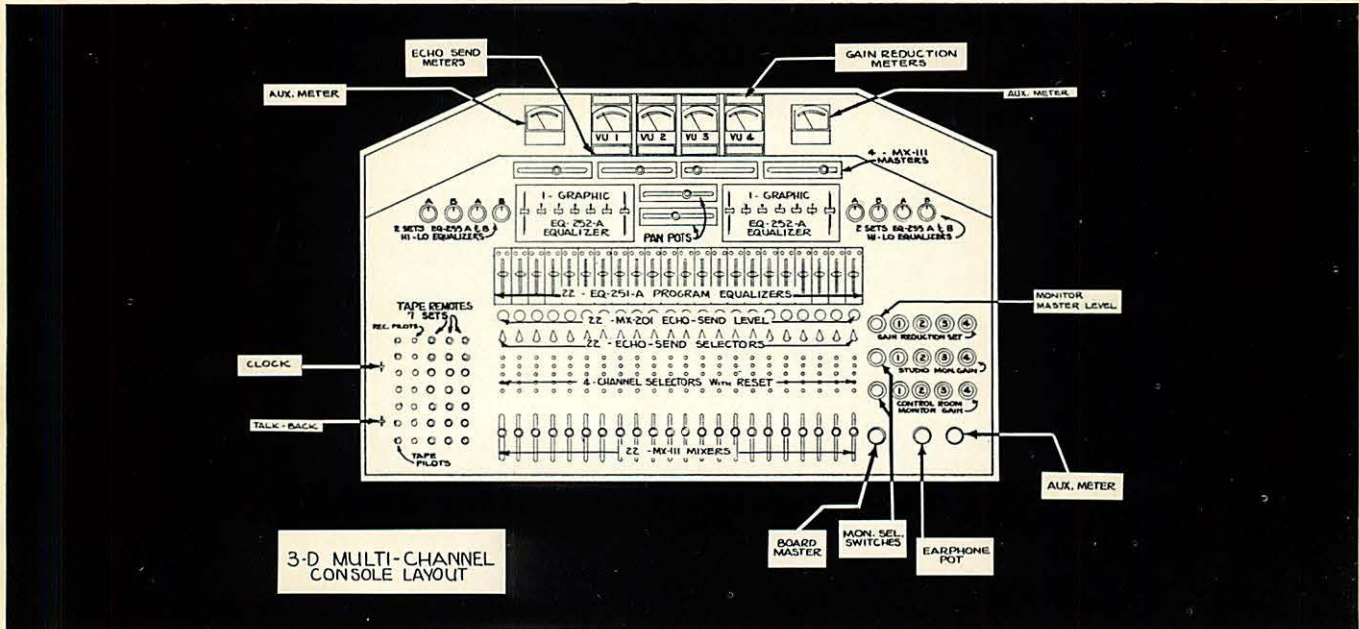

Shown in the layout sketch pictured here are some of the considerations invoked by Langevin's technical assistance. This is a 4 channel recording console exhibiting complete facility, and combines most of the compatible features exploited by console designers during the last 2 years. The use of 4 tracks over the usual 3 permits, for instance, separate track for a soloist so that the performer can repeat or refine his performance.

Starting at the front of the control panel, 22 MX-111 slide wire mixers are shown requiring horizontal space of only 33 inches, all within easy reach of the operator. The shallow depth of Langevin mixers eliminates interference with the recordists knees at the lowest part of the control panel slope.

Any microphone is instantly switchable to any channel through the 4 color coded channel selector pushbuttons. Each pushbutton has 2 circuits, so that the individual echo for the particular microphone is switched with it. The 5th pushbutton is used for reset, disengaging the microphone circuit from the system. Appearing directly above the pushbuttons are the echo selector switches which connect the Echo-Send line ahead of the MX-111 mixer control, or after the mixer control. In the "ahead" position the echo is not affected by the mixer control; in the "after" position, echo fades with the signal as the mixer is closed. The center position of the switch is "off". Intensity of the echo in proportion to the original signal is controlled by the small, 1½ inch diameter 20 step MX-201 ladder controls. The MX-201 diameter is actually slightly less than 1½ inches, but careful panel drilling is necessary to permit easy mounting and alignment; adjacent units can touch.

On pages 42 through 43 the importance of individual spectral control over each microphone channel is treated on. For this reason an EQ-251-A Program Equalizer is shown in each microphone circuit. As an added facility in rerecording to the composite 2 track product for eventual processing to tape or disc, 2 model EQ-252-A Graphic Equalizers give

precise control over the entire spectrum at the 7 subjectively significant frequency bands. 4 sets of variable high and low pass effects filters, models EQ-255-A and B, are indicated at upper right and left, normalized into 4 channels. Inasmuch as all components appear on the jack field (not shown) for routine test, these units can be patched into any channel desired as well as cascaded for violent effects into a single channel.

Situated between the 2 Graphic Equalizers are 2 1:3 channel Pan Pots. These are normalized into 2 microphone channels. Pan Pots provide the ability to shift the apparent source smoothly from one position to left, center or right as desired during the recording.

Four masters (actually board submasters) appear on the control panel nearest the dashboard. These are mounted horizontally to conserve control panel depth and to allow easy reach. An overall rotary board master control is located at lower right.

Standard Model VU-862-X illuminated VU meters form the nucleus of the meter cluster; 4 Simpson VU meters of the horizontal type indicate Gain Reduction, and 4 additional of the same read Echo-Send level in each channel. 2 auxiliary VU meters operate from a dual switch on the lower right. These may be connected to monitor amplifier outputs while monitor amplifier gains are balanced prior to each session. They may be used for balancing studio speaker levels, and for easy monitoring of 2 channel rerecording to disc or tape.

CONCLUSION

The console control panel shown is probably the most elaborate in use today, and has been chosen as an example in this section to indicate the numerous facilities which can be placed within the reach of a single operator. Without Langevin's modern, miniaturized components designed specifically for stereo, fewer controls become necessary.

CUSTOM DESIGNS WITH LANGEVIN MODULAR COMPONENTS

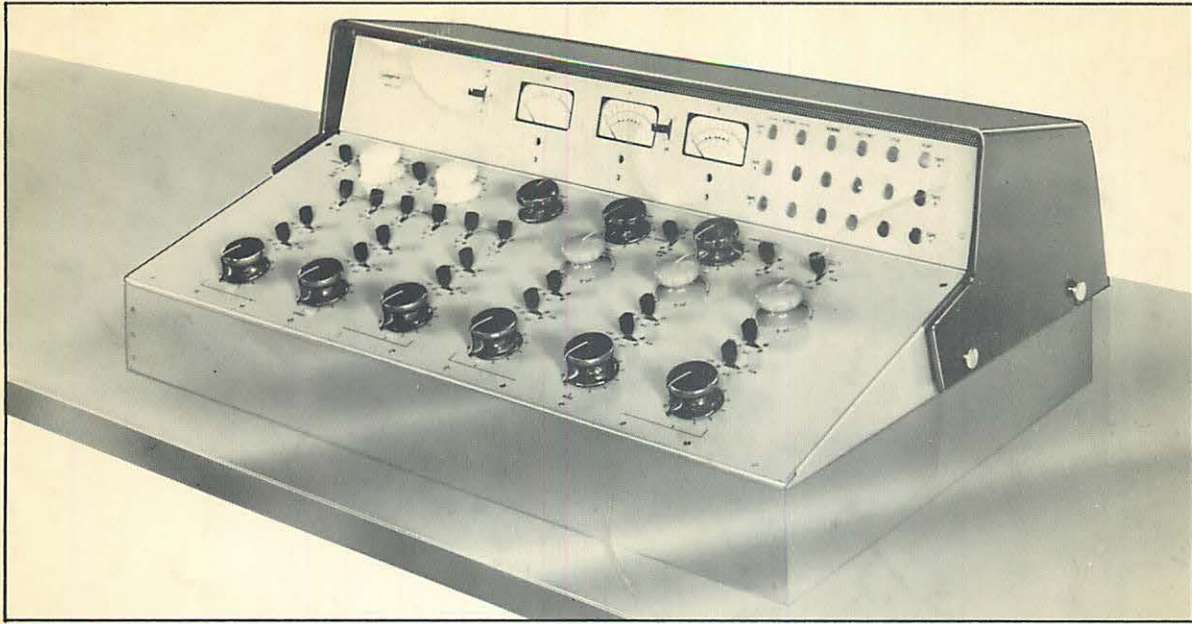

MODEL 3505 for FM-Stereo Broadcasters who desire recording facility. Model 1699-2 housing is shown. Recesses 4 inches into desk. This unit provides unusual switching, permits spot recordings while station is on the air and accommodates re-

notes for three tape machines. Suitable for assembly by individuals. Construction details are available through your distributor or by writing the factory.

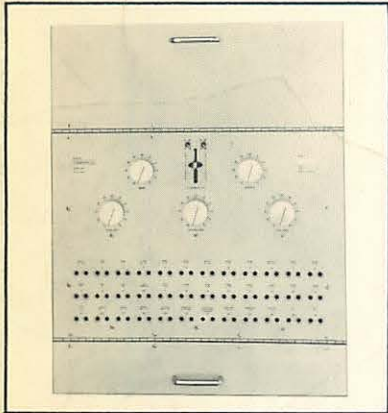

SPECIAL MIXER CONTROL AND AMPLIFIER. This photograph illustrates clean appearance and the manner in which Langevin components accommodate to specialized mechanical arrangements.

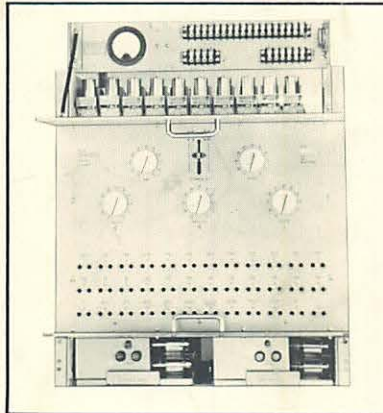

VIEW OF SPECIAL UNIT WITH PANELS OPEN. Access to Metering buttons on AM-5116-B preamplifier and Tube Check Meter is shown, along with compact plug-in Model PS-5206 Power Supplies.

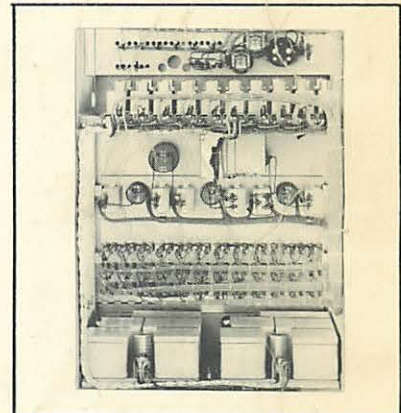

REAR VIEW. Illustrating ease of cabling and neat uncluttered appearance when Langevin components are employed throughout the assembly.

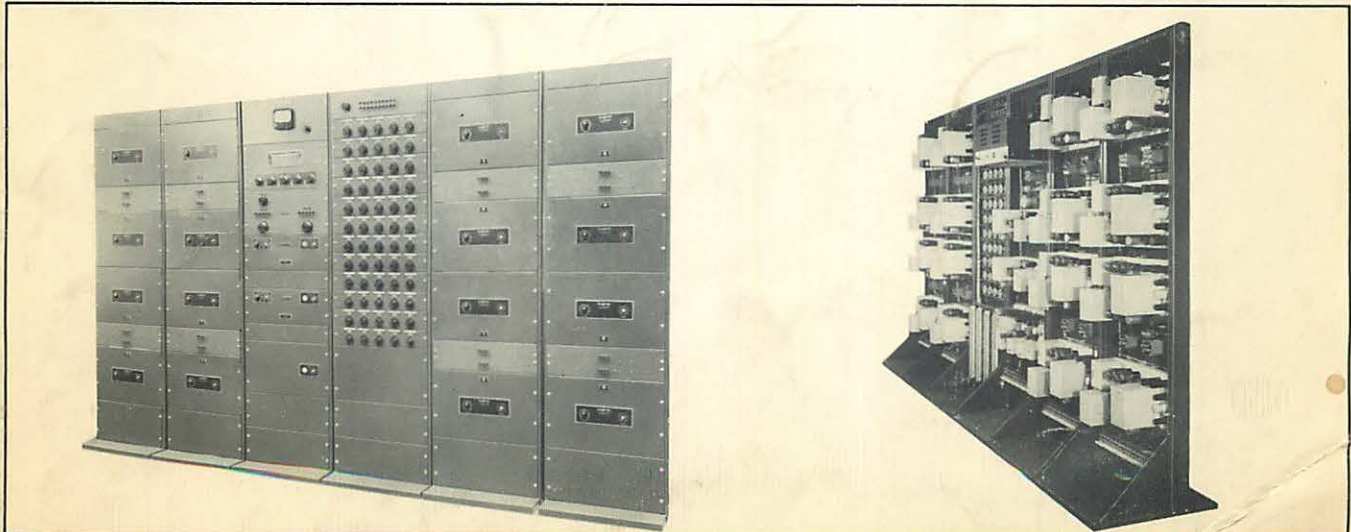

BANK OF LANGEVIN STOCK AMPLIFIERS installed by MUZAK CORPORATION in the building of MUTUAL LIFE INSURANCE COMPANY OF NEW YORK 55th Street and Broadway, New York City

**Over Thirty Years
of Experience . . .**

Since 1923 the Langevin name has been identified with the best in sound systems and audio equipment. Its commercial products include a line of amplifiers, power supplies and transformers for radio broadcast and television stations and studios, recording studios, public address systems, industrial inter-communication systems and music services. The acceptance of these products by such organizations as Columbia Broadcasting System, Voice of America, Muzak and the Armed Forces Radio Service attest to the high standing of Langevin equipment among radio and sound engineers.



A DIVISION OF SONOTEC INCORPORATED • Export: Simonrice
503 South Grand Avenue, Santa Ana, California