

Unless otherwise specified, All diodes are type 1n4148

| REVISION RECORD |                           |          |        |
|-----------------|---------------------------|----------|--------|
| LIK             | DESCRIPTION               | APPROVED | DATE   |
| 1               | REVISED FROM 4988 to 4923 | GH       | 8/2008 |
| 2               | 4966 to ADG412            | GH       | 7/2011 |

SYSTEM

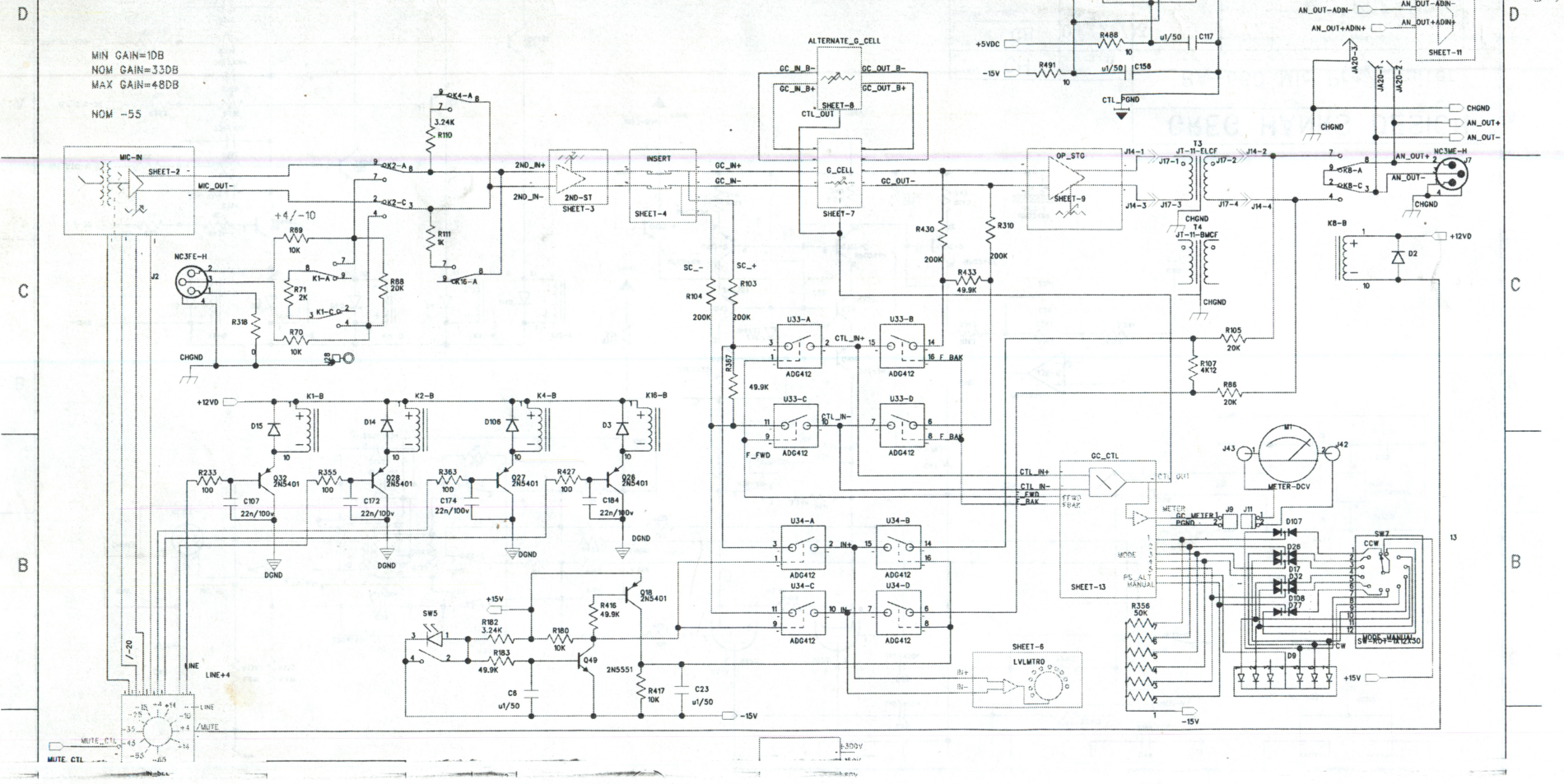

**GREG HANKS DESIGN**

TITLE: BA-660 Mic Pre/Limiter

|              |                  |                  |              |             |           |
|--------------|------------------|------------------|--------------|-------------|-----------|
| DRAWN: GH    | DATE: 10/2/94    | CODE:            | SIZE:        | DRAWING NO: | REV: 1002 |
| LAST REV: GH | DATE: 04/21/2013 | QUALITY CONTROL: | RELEASED: GH | DATE:       | DATE:     |

SCALE: 1 OF 12

1003-12-2013-5/1 ✓ 1002

5-4

11.03.13 1/12

| REVISION RECORD |          |          |      |
|-----------------|----------|----------|------|
| LT#             | COO. NO. | APPROVED | DATE |
|                 |          |          |      |
|                 |          |          |      |
|                 |          |          |      |

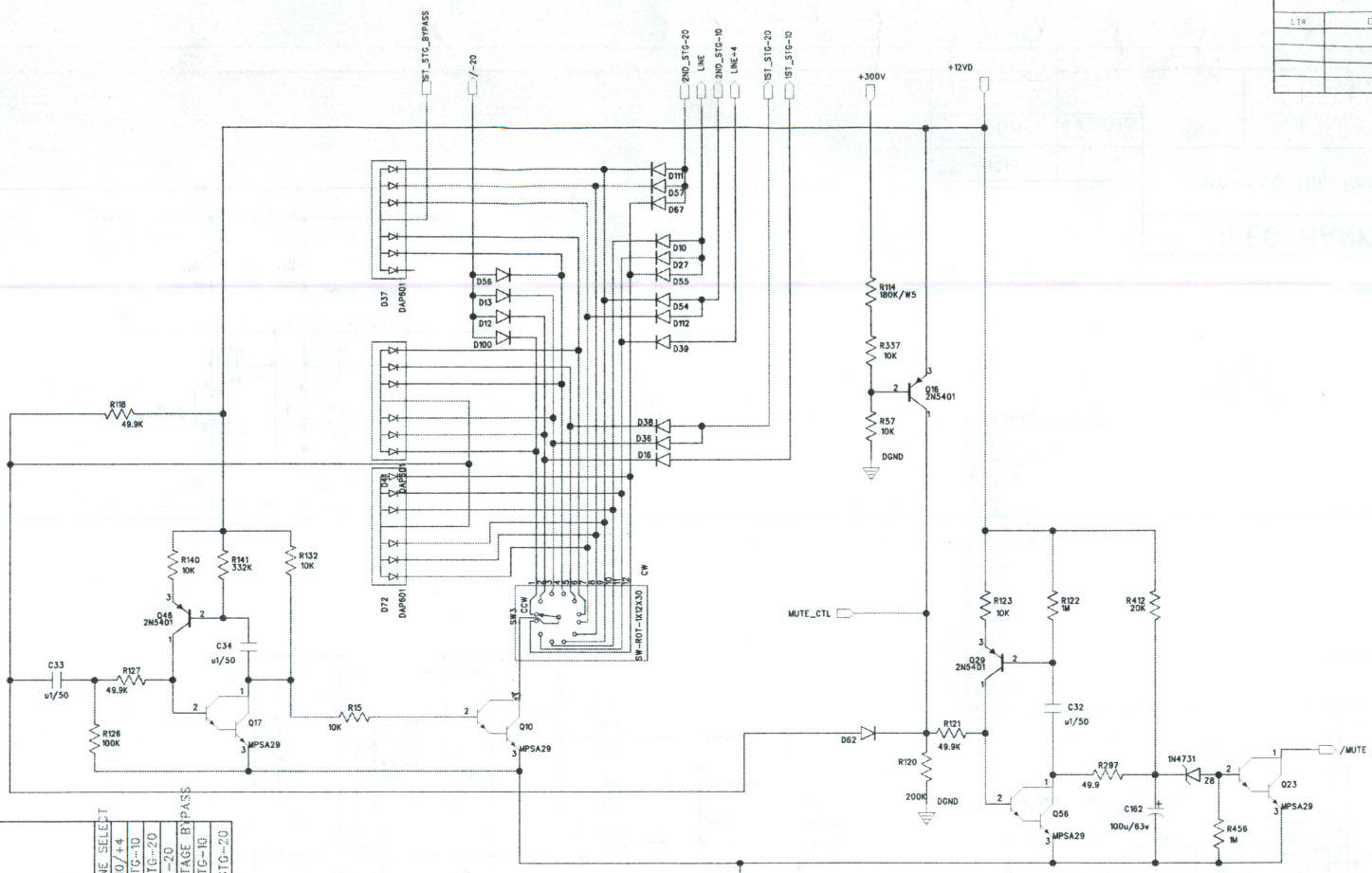

| Relay Switch Logic |      | K2-- MIC/LINE SELECT | K1-- LINE -10/+4 | K14-- 1ST STG-10 | K5,K6-- 1ST STG-20 | K13-- 1ST STAGE BYPASS | K4-- 2ND STG-10 | K16-- 2ND STG-20 |
|--------------------|------|----------------------|------------------|------------------|--------------------|------------------------|-----------------|------------------|
| CW                 | X=ON |                      |                  |                  |                    |                        |                 |                  |

- K1- LINE -10/+4
- K2- MIC/LINE SELECT
- K4- 2ND\_STG-10
- K16- 2ND\_STG-20

| CCW | 10- LINE -10 | 9- MIC +14 | 8- MIC +4 | 7- MIC -5 | 5- MIC -15 | 5- MIC -25 | 4- MIC -35 | 3- MIC -45 | 2- MIC -55 | 1- MIC -65 |
|-----|--------------|------------|-----------|-----------|------------|------------|------------|------------|------------|------------|
|     | X            |            |           |           |            | X          | X          | X          | X          | X          |

- K7- INSERT BYPASS
- K8- O/P MUTE
- K9- PHASE INVERT
- K11- OP UNBAL -
- K12- OP UNBAL +
- K13- 1ST STAGE BYPASS
- K14- 1ST STG-10
- K15- GR BYPASS
- K17- 1ST\_STG-20

|                              |                |                         |                |
|------------------------------|----------------|-------------------------|----------------|
| <b>GREG HANKS DESIGN</b>     |                |                         |                |
| TITLE: BA-66 Mic Pre/Limiter |                |                         |                |
| DRAWN: GH                    | DATED: 10/1/94 | CODE:                   | SIZE:          |
| LAST REV: GH                 | DATED: 04-2013 | DRAWING 100             |                |
| QUALITY CONTROL:             | DATED:         | INP SEL & MUTE CTL 1002 |                |
| RELEASED: GH                 | DATED:         | SCALE:                  | SHEET: 2 OF 12 |

2/12

1003-15-2013-2/1 1005 2-2

4-5-13

| REVISION RECORD |                               |          |        |
|-----------------|-------------------------------|----------|--------|
| LYR             | ECO NO.                       | APPROVED | DATE   |
| 1               | Changed R244 and R344 to 3k24 |          | 6/2012 |
| 2               | Changed R124 to 249           |          | 6/2012 |
| 3               | Tied Q36 thru Q39 TO GND      |          | 6/2012 |

D

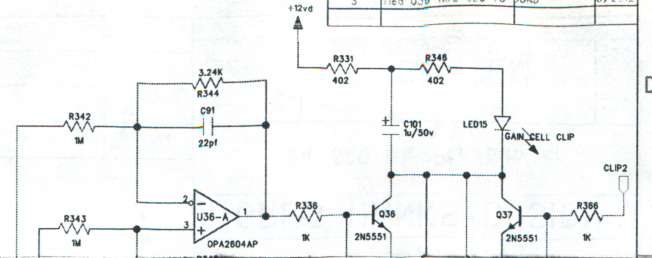
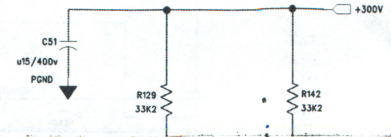
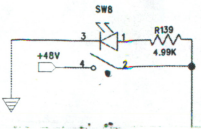

C

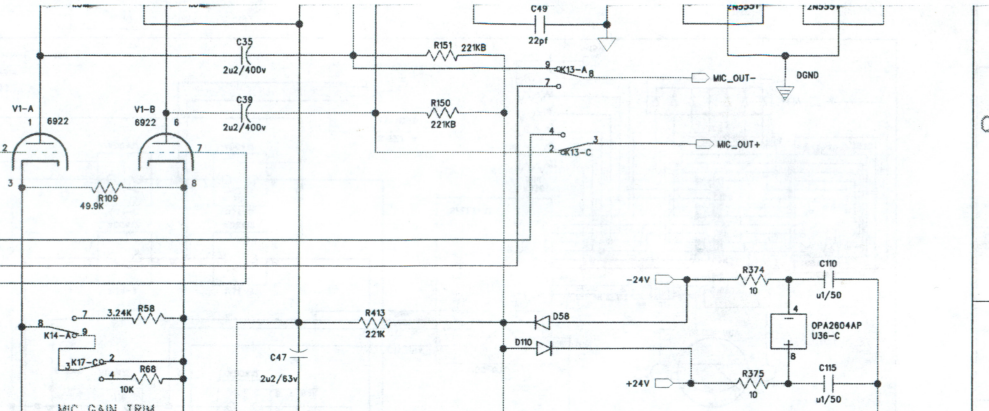
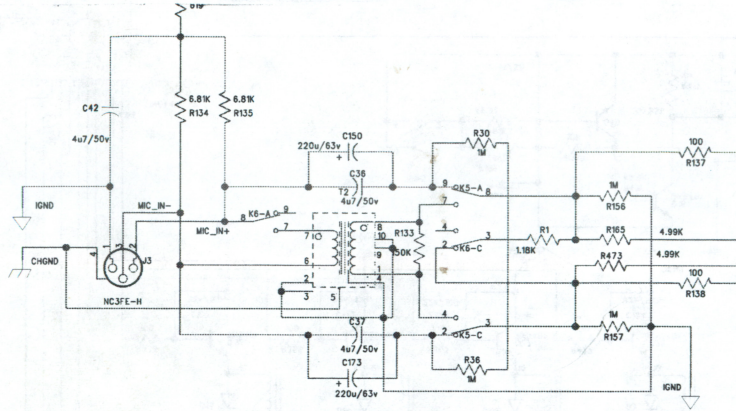

B

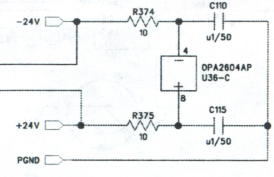
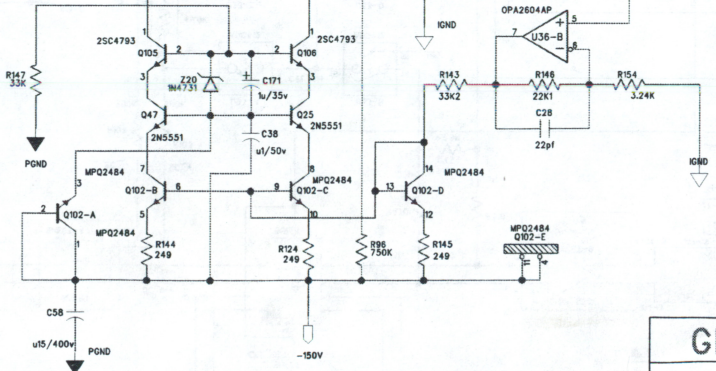
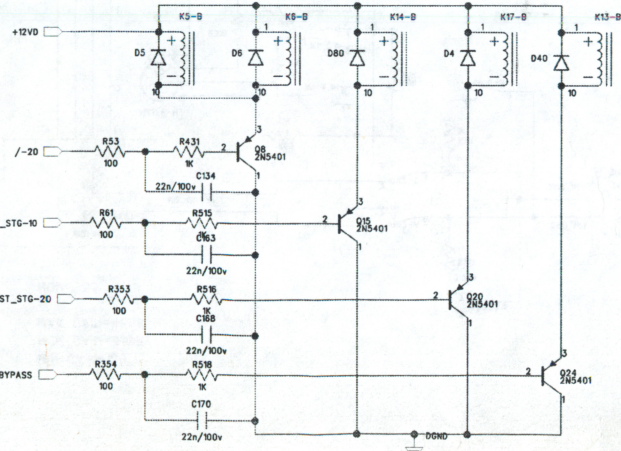

A

|                               |                |              |                |
|-------------------------------|----------------|--------------|----------------|
| GREG HANKS DESIGN             |                |              |                |
| TITLE: BA-660 Mic Pre/Limiter |                |              |                |
| DRAWN: GH                     | DATE: 9/9/94   | CODE:        | SIZE:          |
| LAST REV: GH                  | DATE: 04/21/13 | DRAWING NO.: | REV.:          |
| QUALITY CONTROL:              | DATE:          | MIC PREAMP   | 1002           |
| RELEASED: GH                  | DATE:          | SCALE:       | SHEET: 3 OF 12 |

3/12

6

5

4

3

2

1

| REV | DESCRIPTION                   | APPROVED | DATE    |
|-----|-------------------------------|----------|---------|
| 1   | Changed VR1 to Bourne 91      | GH       | 4/30/12 |
| 2   | R402 and R413 changed to 4.9K | GH       | 6/20/12 |
| 3   | R38 changed to 249R           | GH       | 6/20/12 |

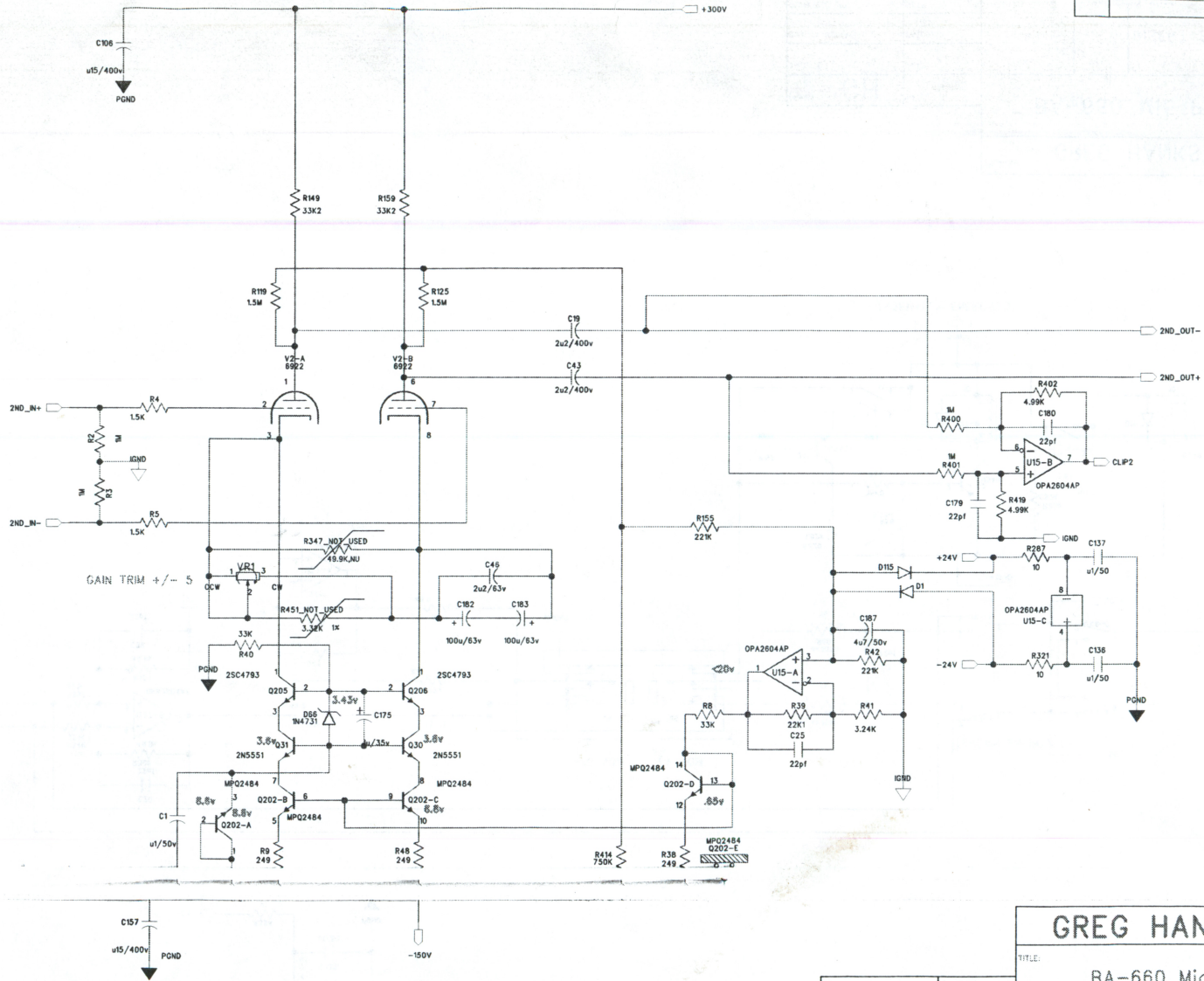

2ND-ST

### GREG HANKS DESIGN

|                        |       |             |                |
|------------------------|-------|-------------|----------------|
| TITLE:                 |       |             |                |
| BA-660 Mic Pre/Limiter |       |             |                |
| CODE:                  | SIZE: | DRAWING NO. | REV.           |
|                        |       | 2ND STAGE   | 1002           |
| SCALE:                 |       |             | SHEET: 4 OF 12 |

|                  |    |        |           |
|------------------|----|--------|-----------|
| DRAWN:           | GH | DATED: | 9/9/94    |
| LAST REV:        | GH | DATED: | 4/21/2013 |
| QUALITY CONTROL: |    | DATED: |           |
| RELEASED:        | GH | DATED: |           |

4/12

6

5

4

3

2

1

| REVISION RECORD |         |          |      |
|-----------------|---------|----------|------|
| LTR             | ECO NO. | APPROVED | DATE |
|                 |         |          |      |
|                 |         |          |      |
|                 |         |          |      |

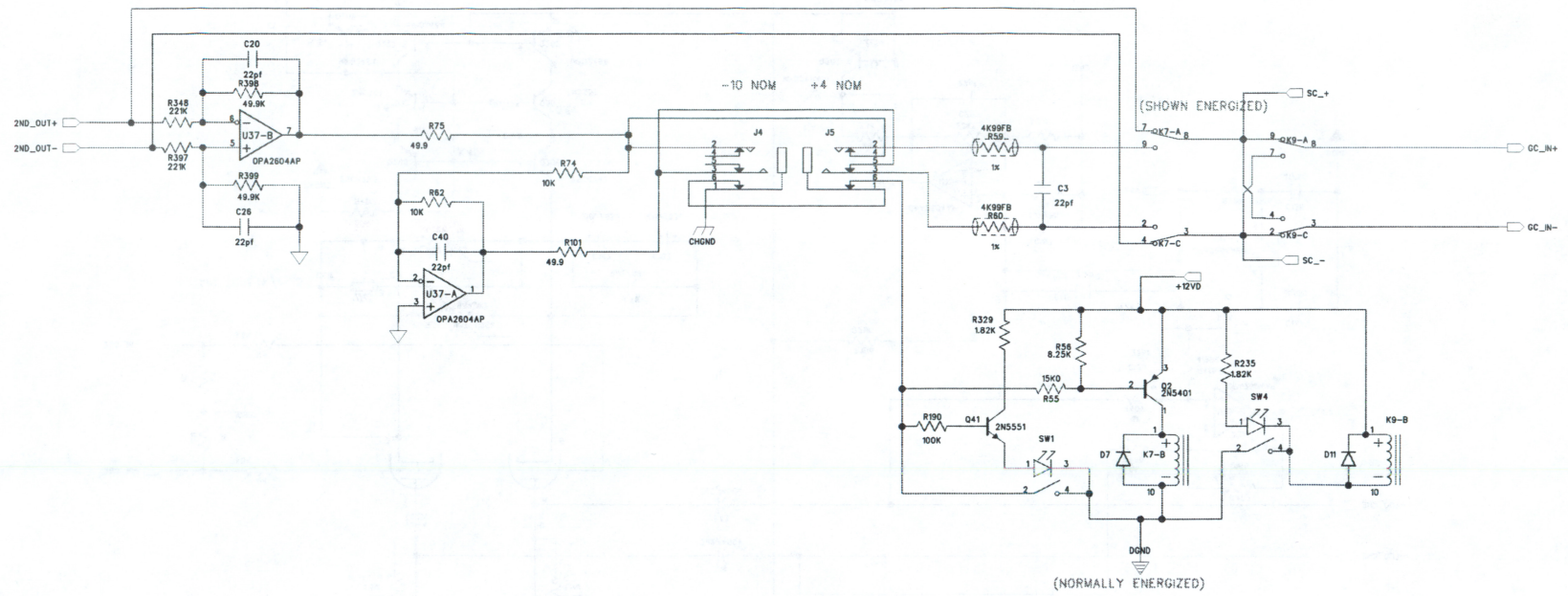
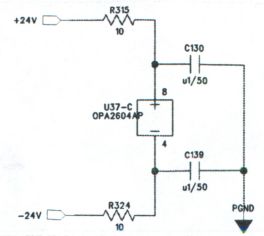

INSERT

|                               |               |                     |           |
|-------------------------------|---------------|---------------------|-----------|
| COMPANY: GREG HANKS DESIGN    |               |                     |           |
| TITLE: BA-660 Mic Pre/Limiter |               |                     |           |
| DRAWN: GH                     | DATED: 5/5/95 | DESIGN NO.          | REV: 1002 |
| CHECKED:                      | DATE:         | SCALE:              |           |
| QUALITY CONTROL:              | DATE:         | INSERT SEND AND RTN |           |
| RELEASED: GH                  | DATE: 04-2013 | SHEET: 5 of 12      |           |

5/12



| REVISION RECORD |                      |          |        |
|-----------------|----------------------|----------|--------|
| LTN             | ECO NO.              | APPROVED | DATE   |
| 1               | DB from 50k to 500k  | GH       | 5/2012 |
| 2               | R483 from 10k to 50k | GH       | 5/2012 |
| 3               | Adj C2 u1/35v Inst   | GH       | 5/2012 |
| 4               | Removed TR2          | gh       | 7/2012 |
| 5               | Added TR3 and R45    | GH       | 7/2012 |

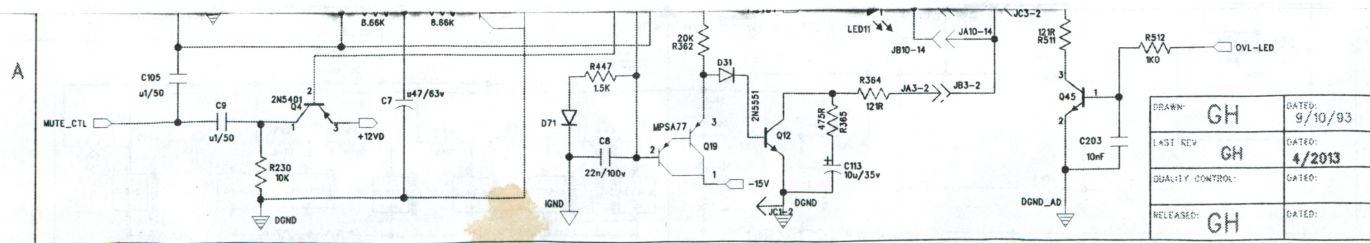
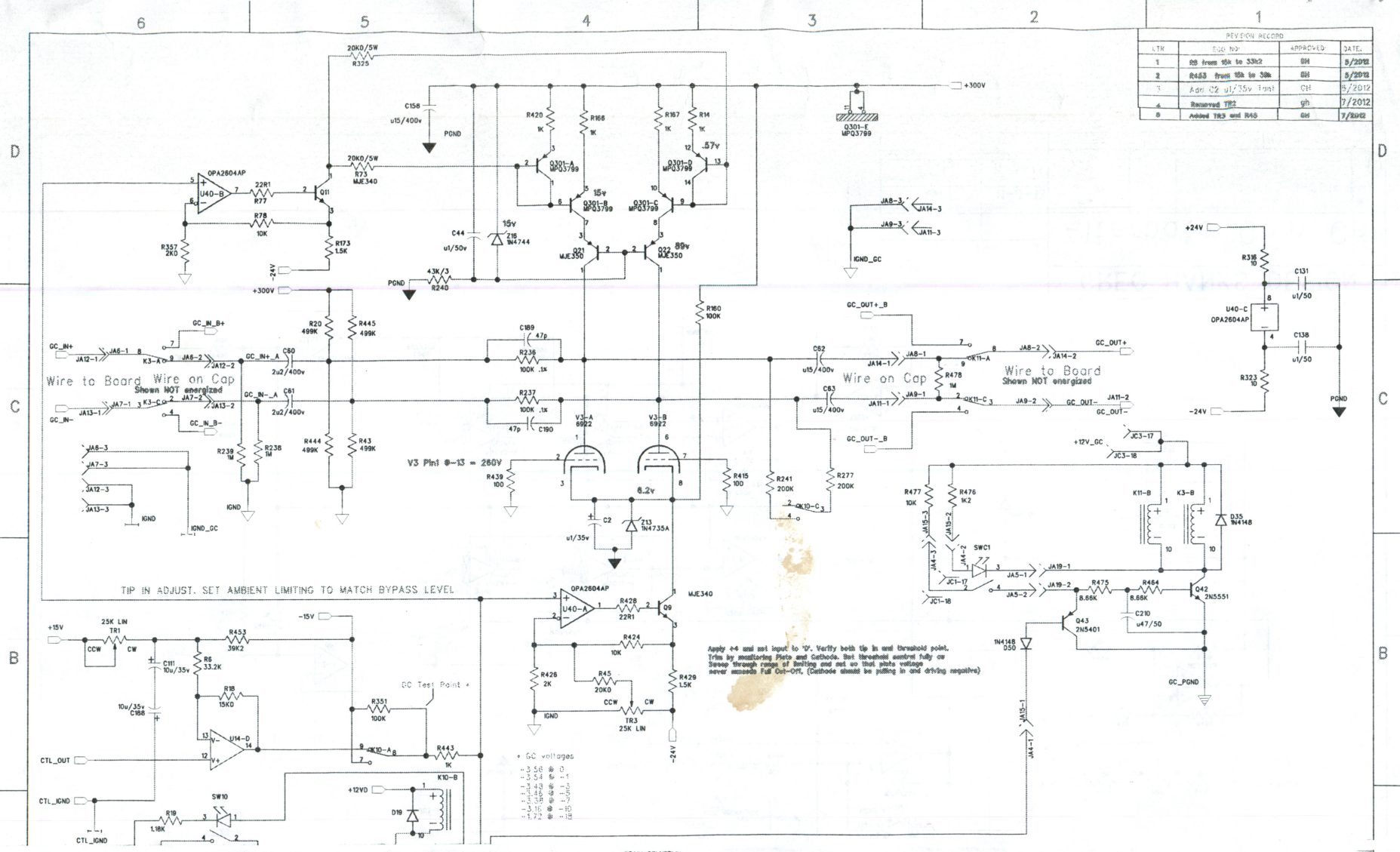

|                               |                |                         |           |
|-------------------------------|----------------|-------------------------|-----------|
| <b>GREG HANKS DESIGN</b>      |                |                         |           |
| TITLE: BA-660 Mic Pre/Limiter |                |                         |           |
| DRAWN: GH                     | DATED: 9/10/93 | CODE:                   | SIZE:     |
| LAST REV: GH                  | DATED: 4/2013  | DRAWING NO:             | REV: 1002 |
| QUALITY CONTROL:              | DATED:         | <b>GAIN CELL</b>        |           |
| RELEASED: GH                  | DATED:         | BA-660 1003-12-2013 5-4 |           |
| SHEET: 7                      |                | OF: 12                  |           |

7/12

OP\_STG

| REVISION RECORD |                      |           |          |
|-----------------|----------------------|-----------|----------|
| LTN             | EDU NO.              | APPROVED: | DATE:    |
| R454            | to 0                 | GH        | 05-07-12 |
| R455            | not used             | GH        | 05-07-12 |
| R93             | changed to .249R     |           | 3/2012   |
| J4-J5           | added to correct BDM |           |          |

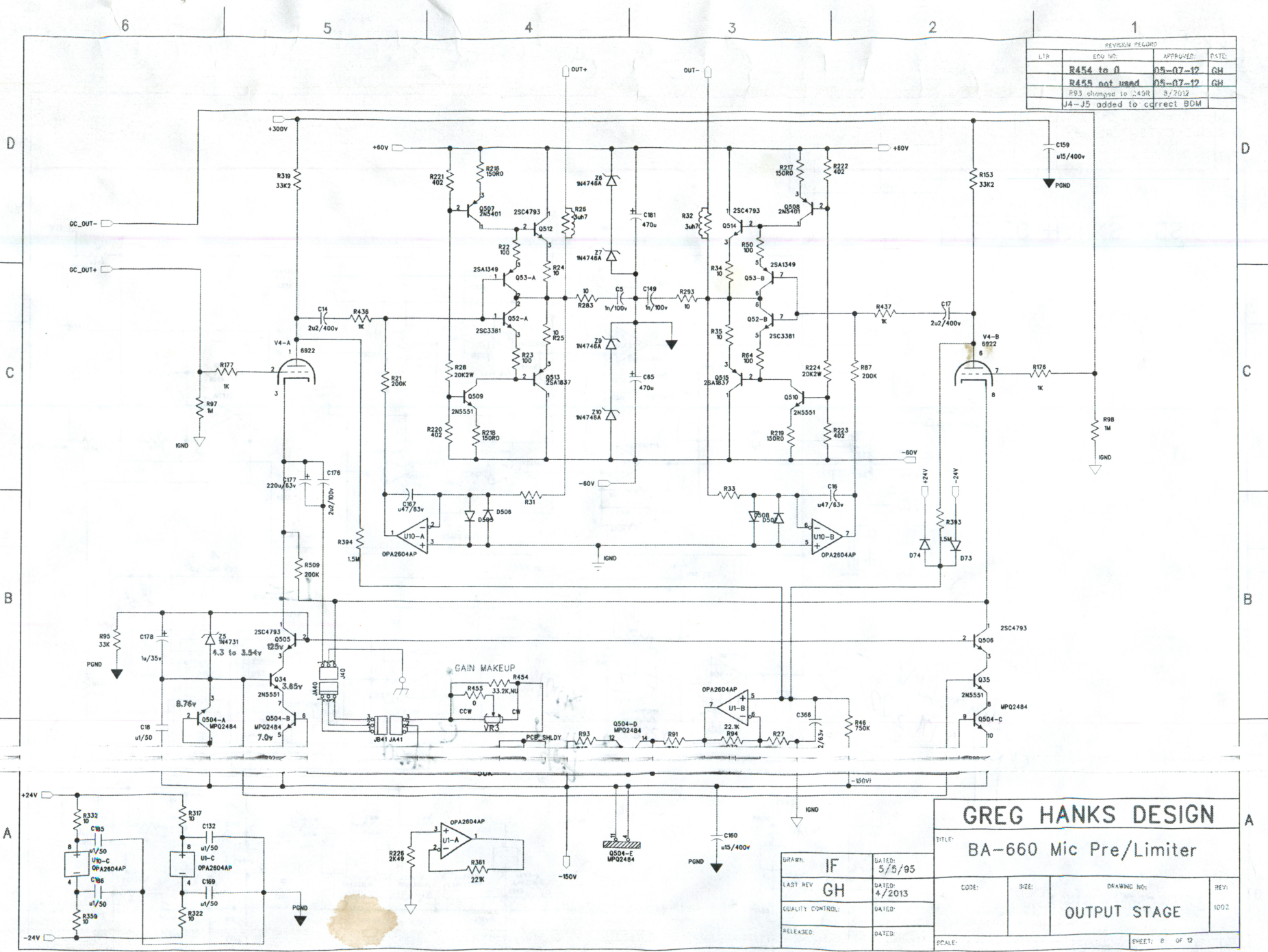

**GREG HANKS DESIGN**

TITLE: **BA-660 Mic Pre/Limiter**

OUTPUT STAGE

|              |              |                  |           |              |      |
|--------------|--------------|------------------|-----------|--------------|------|
| DRAWN: IF    | DATE: 5/5/95 | CODE:            | SIZE:     | DRAWING NO.: | REV: |
| LAST REV: GH | DATE: 4/2013 | QUALITY CONTROL: | RELEASED: | DATED:       | 1002 |

SHEET: 0 OF 12

08/12



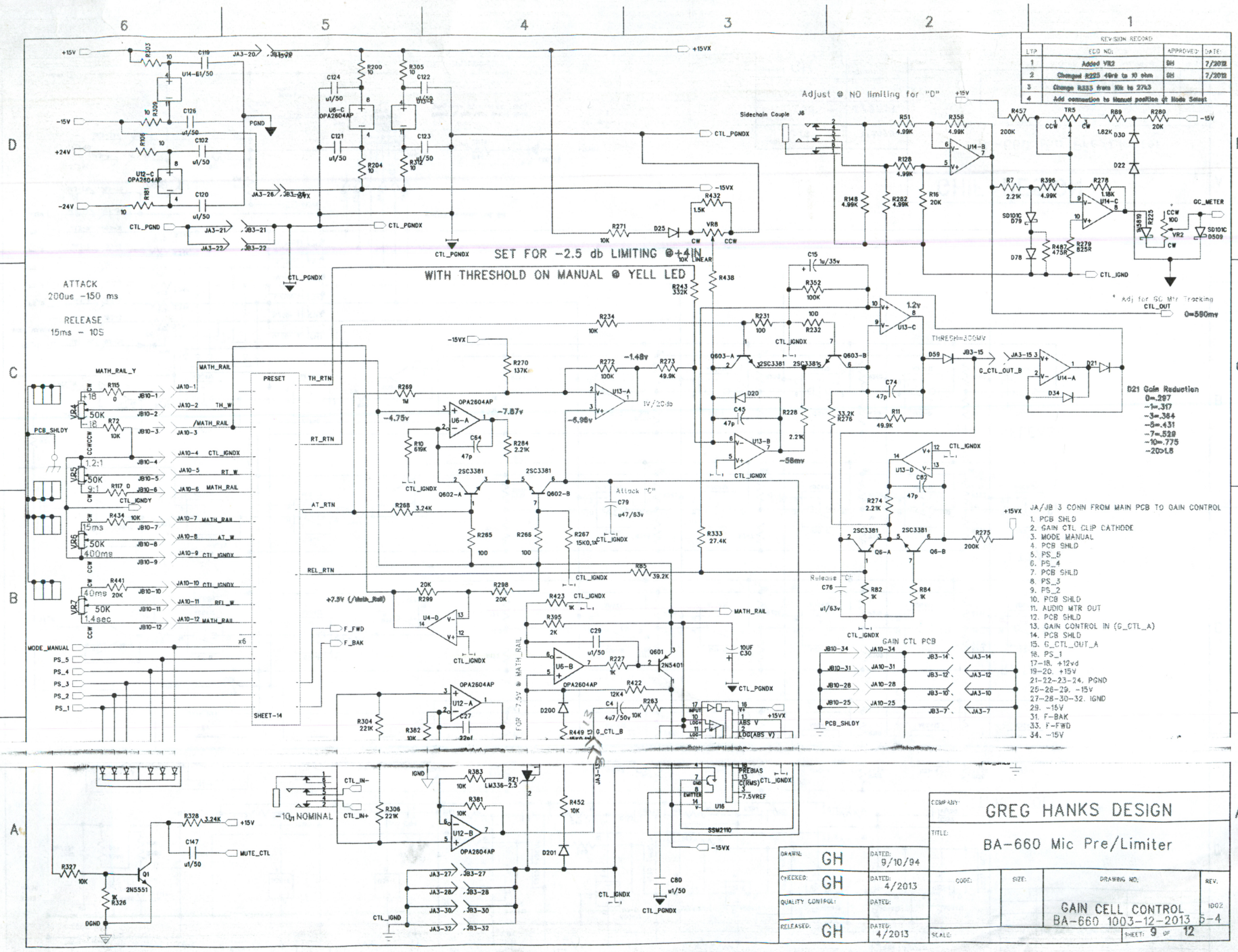

| REVISION RECORD |  |          |        |
|-----------------|--|----------|--------|
| ITP             | ECO NO.  | APPROVED | DATE   |
| 1               | Added VR2  | BH       | 7/2012 |
| 2               | Change R223 40k to 30 ohm                        | BH       | 7/2012 |
| 3               | Change R223 from 10k to 27k3                     | BH       |        |
| 4               | Add connection to Manual position of Mode Select |          |        |

- JA/JB/3 CONN FROM MAIN PCB TO GAIN CONTROL
1. PCB SHLD
  2. GAIN CTL CLIP CATHODE
  3. MODE MANUAL
  4. PCB SHLD
  5. PS\_5
  6. PS\_4
  7. PCB SHLD
  8. PS\_3
  9. PS\_2
  10. PCB SHLD
  11. AUDIO MTR OUT
  12. PCB SHLD
  13. GAIN CONTROL IN (G\_CTL\_A)
  14. PCB SHLD
  15. G\_CTL\_OUT\_A
  16. PS\_1
  - 17-18. +12vd
  - 19-20. +15v
  - 21-22-23-24. PGND
  - 25-26-29. -15V
  - 27-28-30-32. IGND
  29. -15V
  31. F-BAK
  33. F-FWD
  34. -15V

|                            |              |                               |       |
|----------------------------|--------------|-------------------------------|-------|
| COMPANY: GREG HANKS DESIGN |              | TITLE: BA-660 Mic Pre/Limiter |       |
| DATE: 9/10/94              | DATE: 4/2013 | CODE:                         | SIZE: |
| CHECKED: GH                | DATE: 4/2013 | DRAWING NO.:                  | REV.: |
| QUALITY CONTROL:           | DATE:        | GAIN CELL CONTROL             |       |
| RELEASED: GH               | DATE: 4/2013 | BA-660 1003-12-2013           |       |
| SCALE:                     |              | SHEET: 9 of 12                |       |

9/12

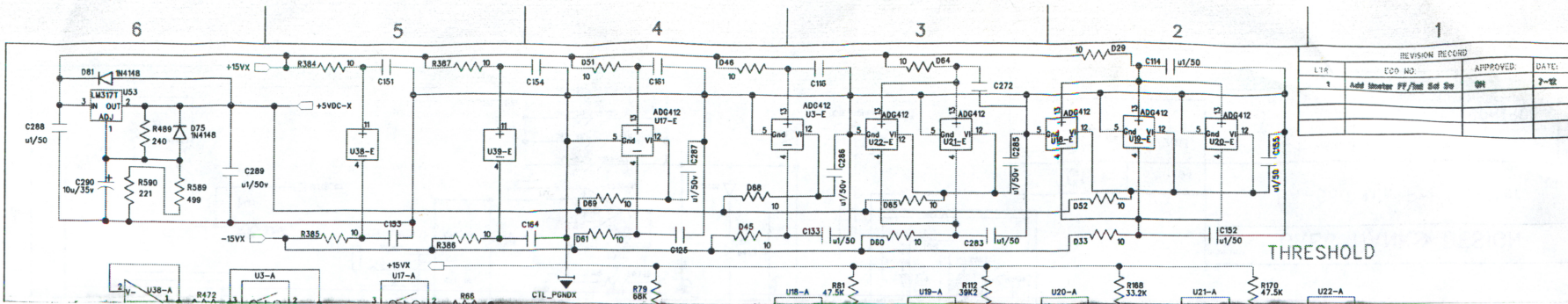

| REVISION RECORD |                          |          |      |
|-----------------|--------------------------|----------|------|
| LTR             | EDD NO                   | APPROVED | DATE |
| 1               | Add Master FF/Rel Set Sw | GH       | 7-02 |

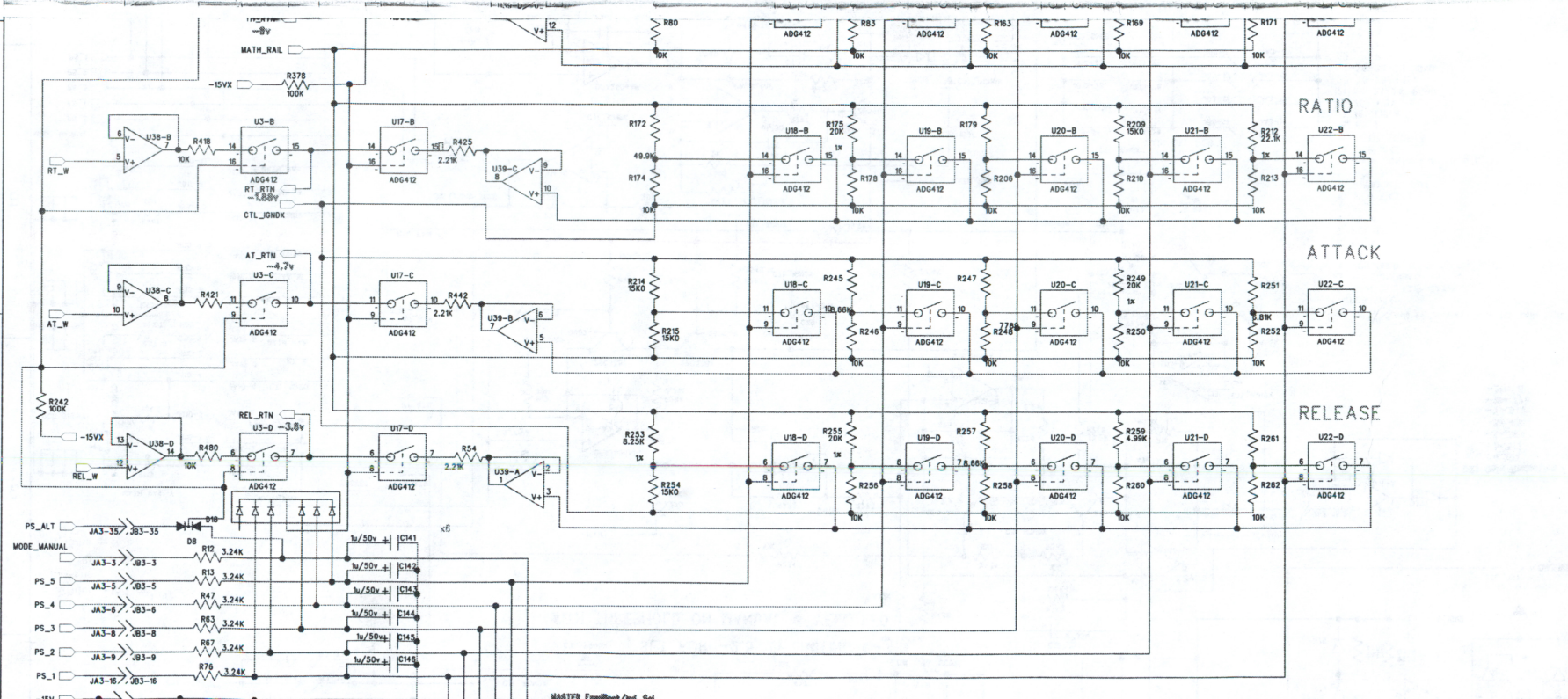

PRESET

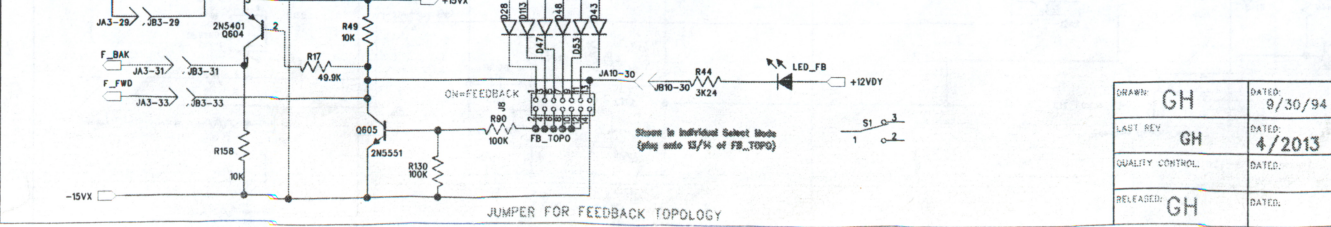

GHIF DESIGN

TITLE: BA-660 Mic Pre/Limiter

|                  |                |        |                     |
|------------------|----------------|--------|---------------------|
| DRAWN: GH        | DATED: 9/30/94 | CODE:  | DRAWING NO:         |
| LAST REV: GH     | DATED: 4/2013  | SCALE: | REV: 1002           |
| QUALITY CONTROL: | DATED:         |        | PRESET FLAVORS      |
| RELEASED: GH     | DATED:         |        | BA-660 1003-12-2013 |

SHEET 10 OF 12

10/12

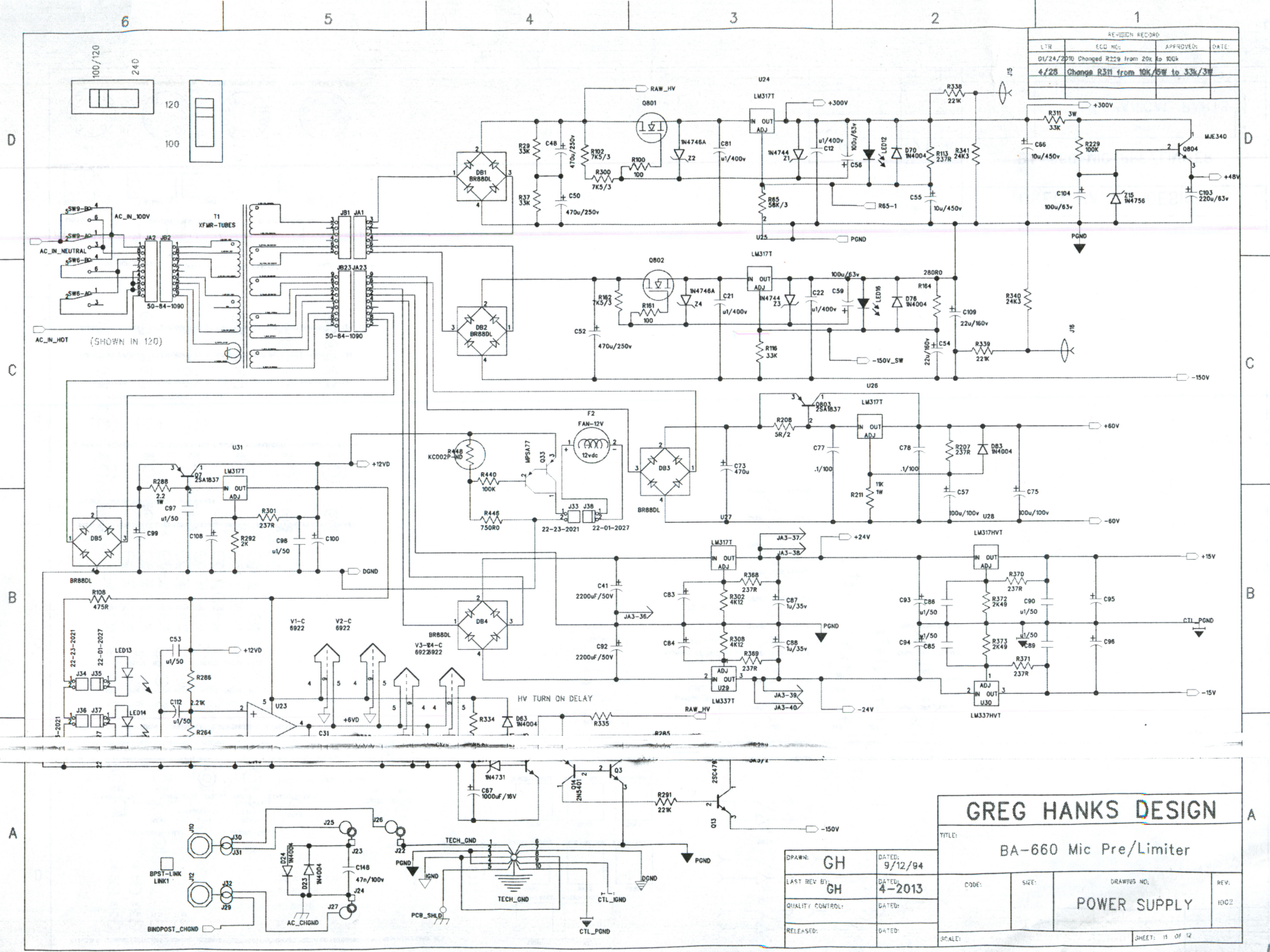

| REVISION RECORD |                                   |           |      |
|-----------------|-----------------------------------|-----------|------|
| LT#             | ECG MGS                           | APPROVED: | DATE |
| DL/24/2010      | Changed R229 from 20k to 100k     |           |      |
| 4/28            | Change R311 from 10K/5W to 33K/3W |           |      |

|                               |       |                     |         |
|-------------------------------|-------|---------------------|---------|
| <b>GREG HANKS DESIGN</b>      |       |                     |         |
| TITLE: BA-660 Mic Pre/Limiter |       |                     |         |
| DRW#:                         | GH    | DATE:               | 9/12/94 |
| LAST REV BY:                  | GH    | DATE:               | 4-2013  |
| QUALITY CONTROL:              |       | DATE:               |         |
| RELEASED:                     |       | DATE:               |         |
| CODE:                         | SIZE: | DRAWING NO.         | REV.    |
|                               |       | <b>POWER SUPPLY</b> | 1002    |
| SCALE:                        |       | SHEET: 11 OF 12     |         |

PWR

11/12

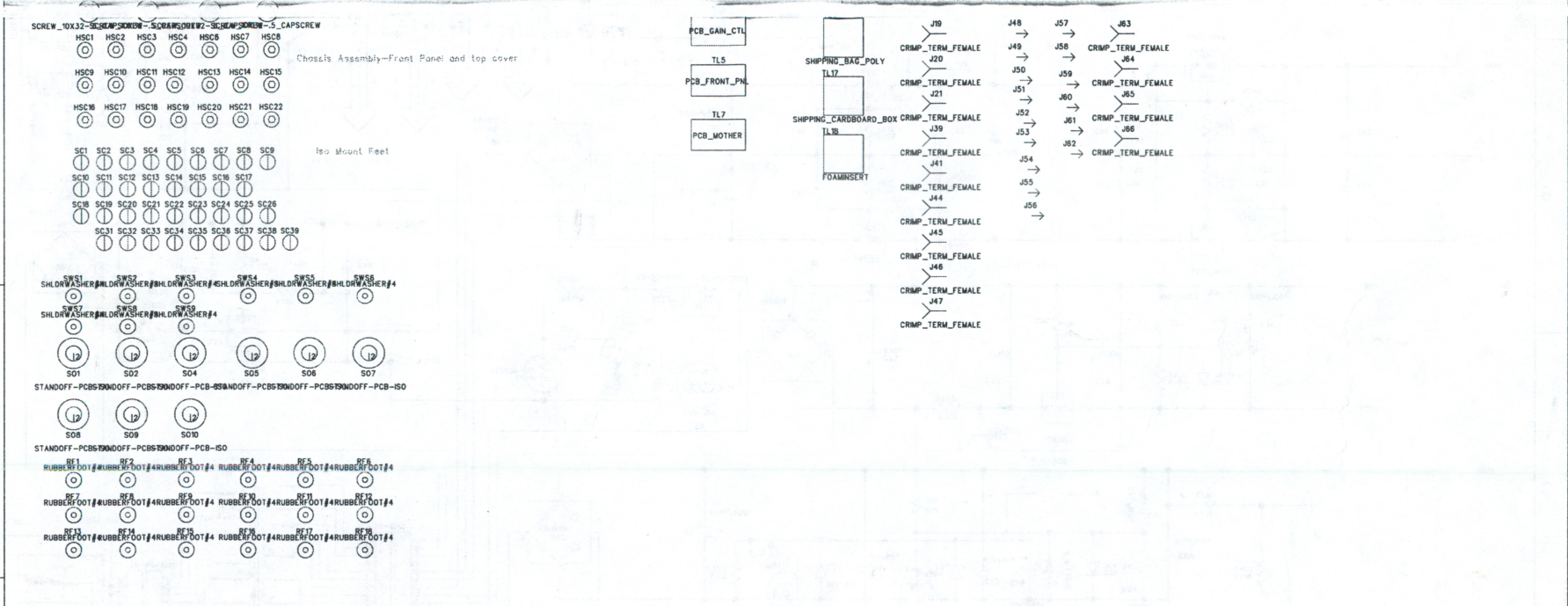
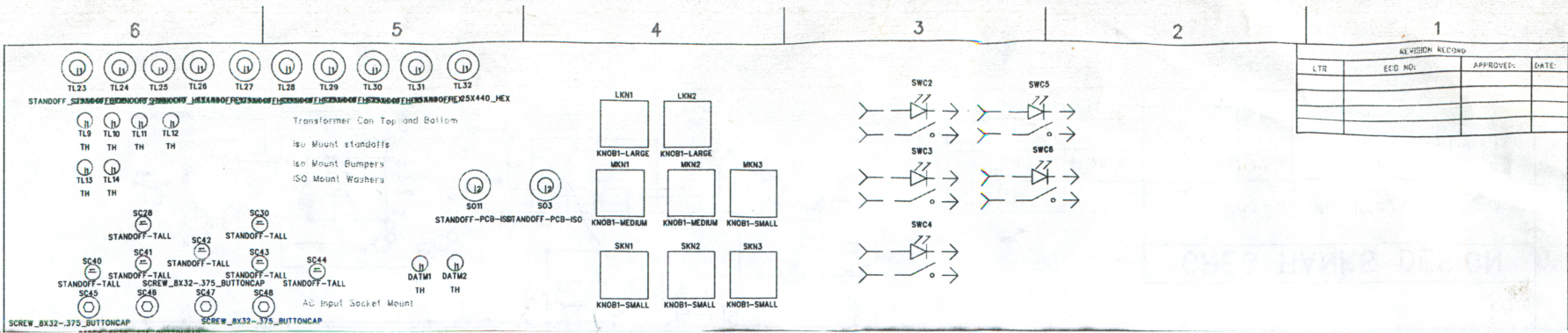

12/12

| REVISION RECORD |      |          |      |
|-----------------|------|----------|------|
| LT#             | ECO# | APPROVED | DATE |
|                 |      |          |      |
|                 |      |          |      |

1. JA22.1 WAS ADC\_IN\_R - NOW R\_ADC\_M\_COM
2. JA22.3 WAS ADC\_DC\_COUPLE\_NOW R\_ADC\_M-
3. JA22.2 WAS AD\_BIP1\_COM\_B NOW ADC\_DC\_COUPLE
4. JA23 WAS L\_ADC\_M- NOW ADC\_DC\_COUPLE

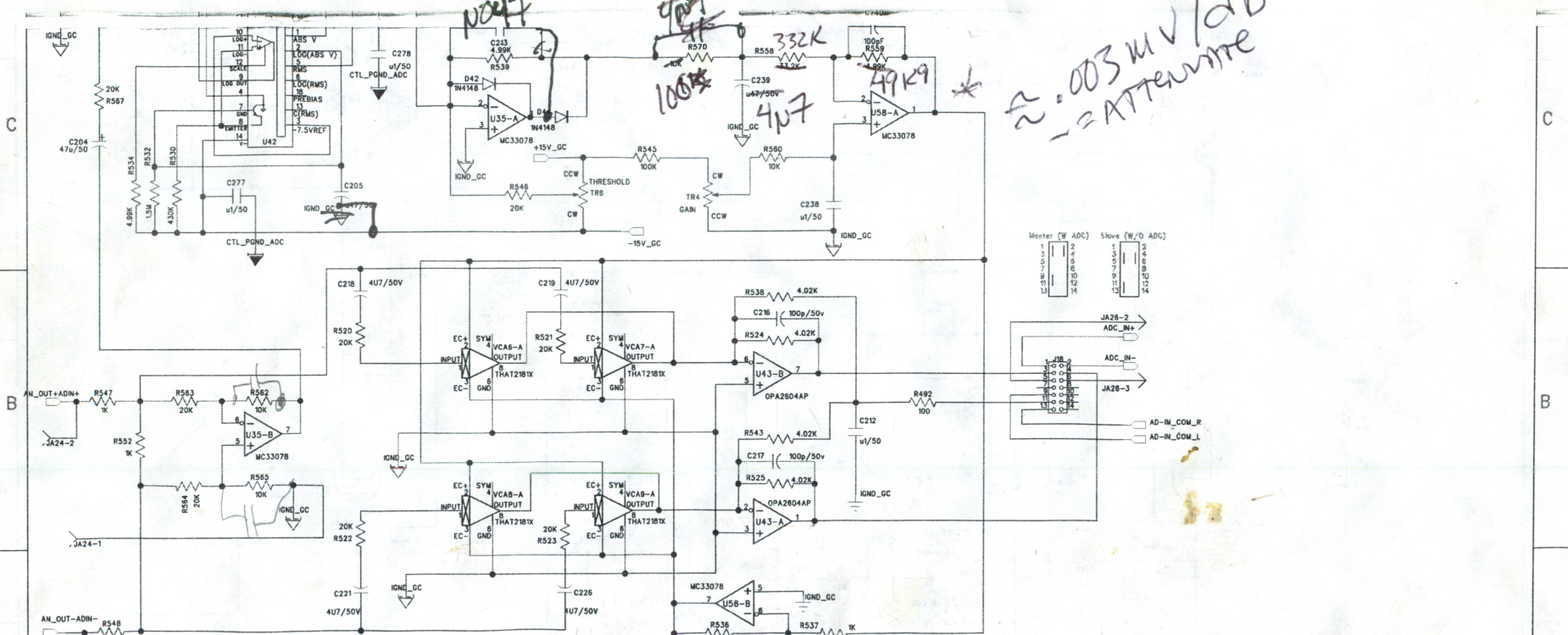
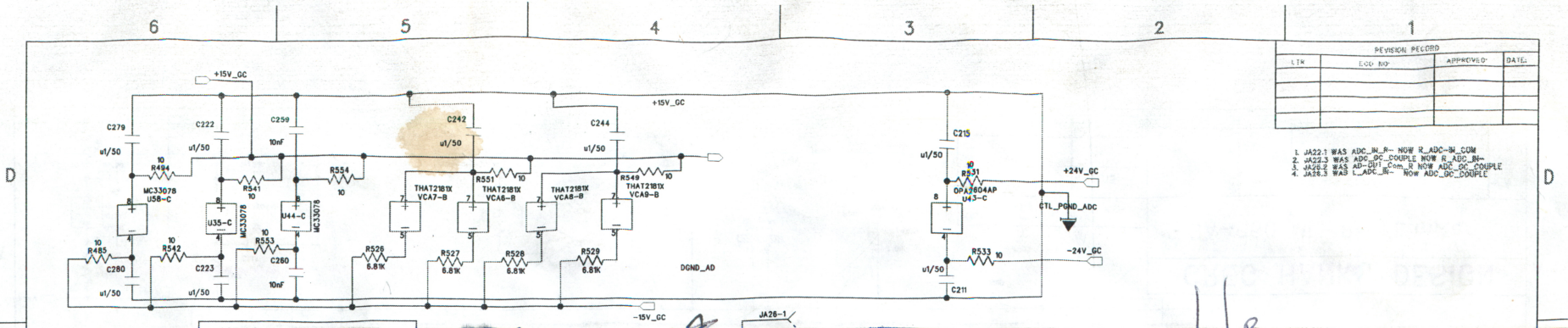

*Handwritten note:*  
 $\approx 0.003 \text{ mV/dB}$   
 $= \text{ATTENUATE}$

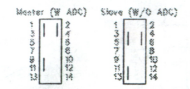

|                          |        |                                 |                |
|--------------------------|--------|---------------------------------|----------------|
| <b>GREG HANKS DESIGN</b> |        |                                 |                |
| TITLE: ADC Gain Cell     |        |                                 |                |
| DRAWN:                   | DATED: | CODE:                           | SIZE:          |
| CHECKED:                 | DATED: | ORIGIN:                         | SCALE:         |
| QUALITY CONTROL:         | DATED: | DRAWING NO: BA-660 1003-12-2013 |                |
| RELEASED:                | DATED: | REV:                            | 5-4            |
| SCALE:                   |        |                                 | SHEET: 1 OF 13 |

*Handwritten:* 13/16

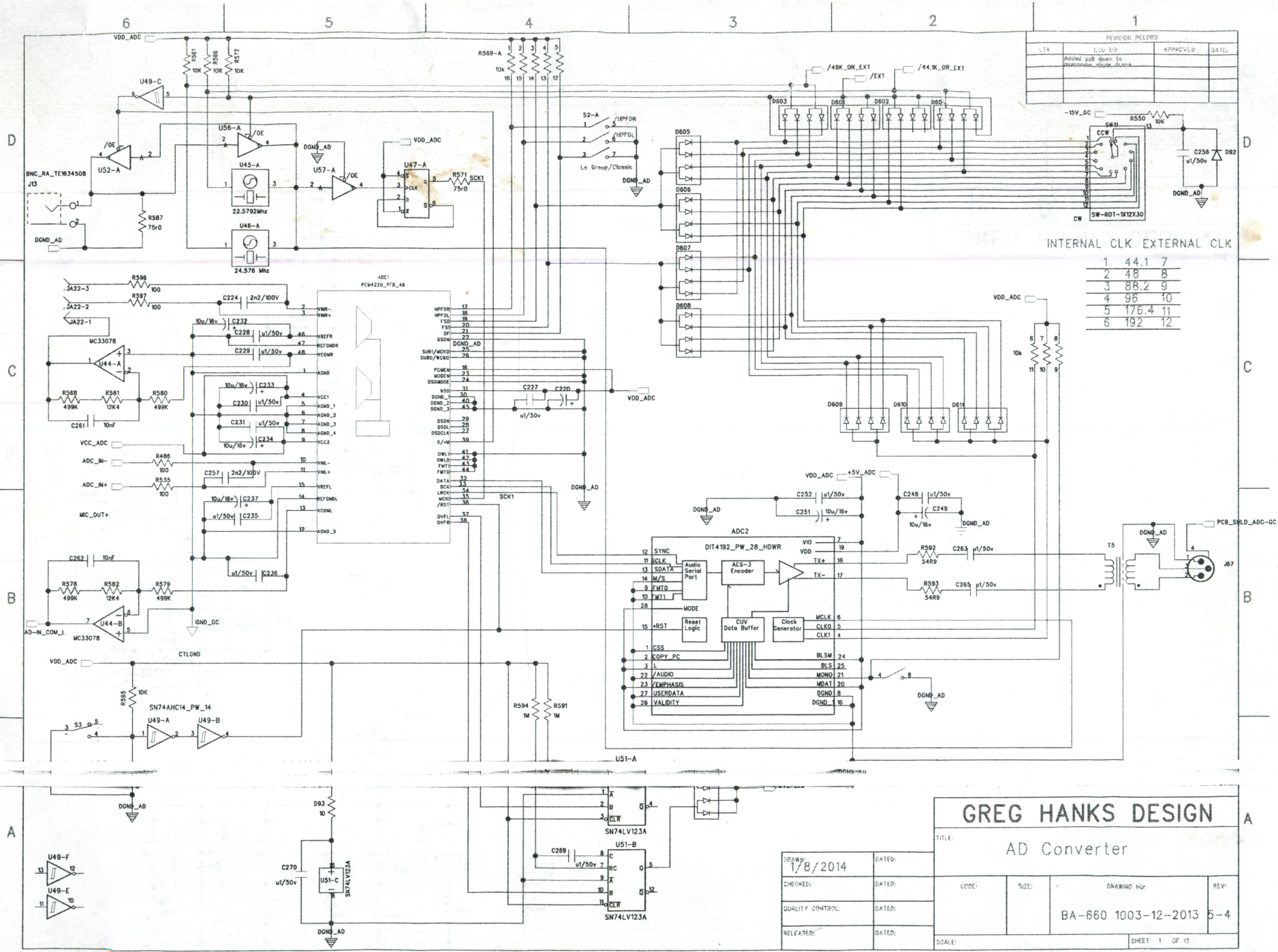

| REVISION RECORD |                             |          |      |
|-----------------|-----------------------------|----------|------|
| LT#             | REV. NO.                    | APPROVED | DATE |
|                 | Added pull down to          |          |      |
|                 | intermediate output signals |          |      |

|   | INTERNAL CLK | EXTERNAL CLK |
|---|--------------|--------------|
| 1 | 44.1         | 7            |
| 2 | 48           | 8            |
| 3 | 88.2         | 9            |
| 4 | 96           | 10           |
| 5 | 176.4        | 11           |
| 6 | 192          | 12           |

**GREG HANKS DESIGN**

TITLE: AD Converter

|                 |        |                  |                |                     |      |
|-----------------|--------|------------------|----------------|---------------------|------|
| DRAWN: 1/8/2014 | DATED: | CODE:            | SIZE:          | DRAWING NO:         | REV: |
| CHECKED:        | DATED: | QUALITY CONTROL: | DATED:         | BA-660 1003-12-2013 | 5-4  |
| RELEASED:       | DATED: | SCALE:           | SHEET: 1 OF 13 |                     |      |

14/16

6

5

4

3

2

1

| REVISION RECORD |         |          |      |
|-----------------|---------|----------|------|
| LT#             | ECO NO# | APPROVED | DATE |
|                 |         |          |      |
|                 |         |          |      |
|                 |         |          |      |

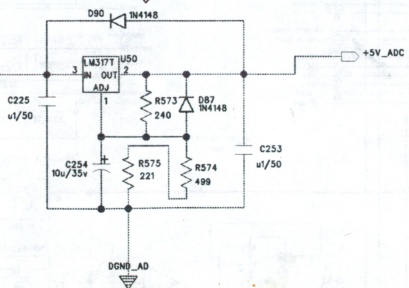
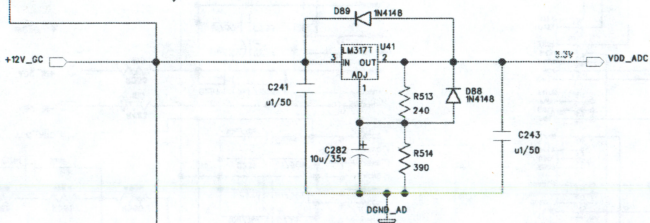
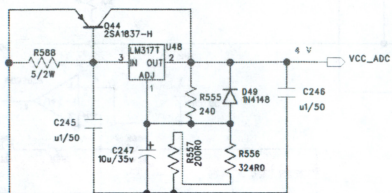
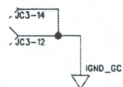
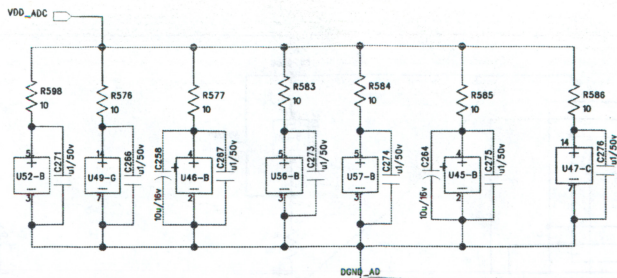

GREG HANKS DESIGN

TITLE: ADC POWER

|                  |        |       |       |                     |      |
|------------------|--------|-------|-------|---------------------|------|
| DRAWN:           | DATED: | CODE: | SIZE: | DRAWING NO:         | REV: |
| CHECKED:         | DATED: |       |       | BA-660 1003-12-2013 | 5-4  |
| QUALITY CONTROL: | DATED: |       |       |                     |      |
| RELEASED:        | DATED: |       |       |                     |      |
| SCALE:           |        |       |       | SHEET: 1 OF 1       |      |

15/16

| REVISION RECORD |         |          |      |
|-----------------|---------|----------|------|
| LTR             | ECO NO. | APPROVED | DATE |
|                 |         |          |      |
|                 |         |          |      |
|                 |         |          |      |

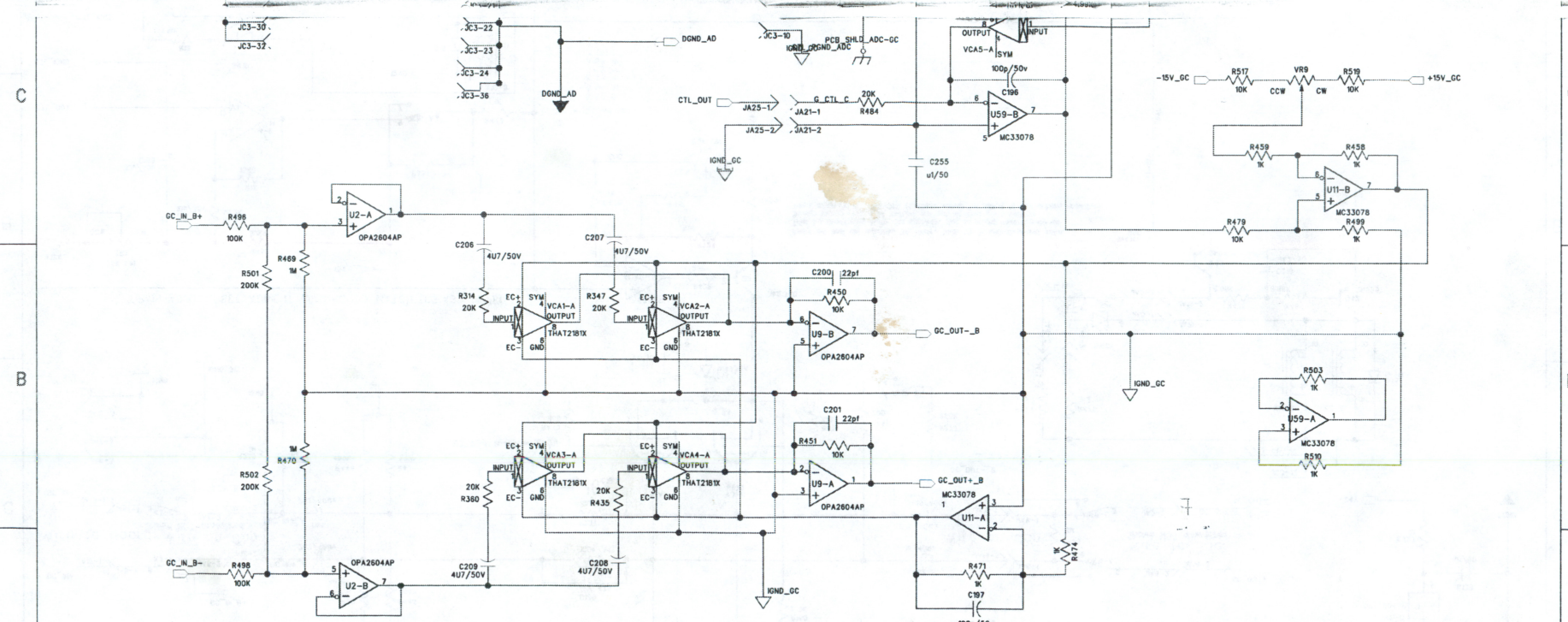
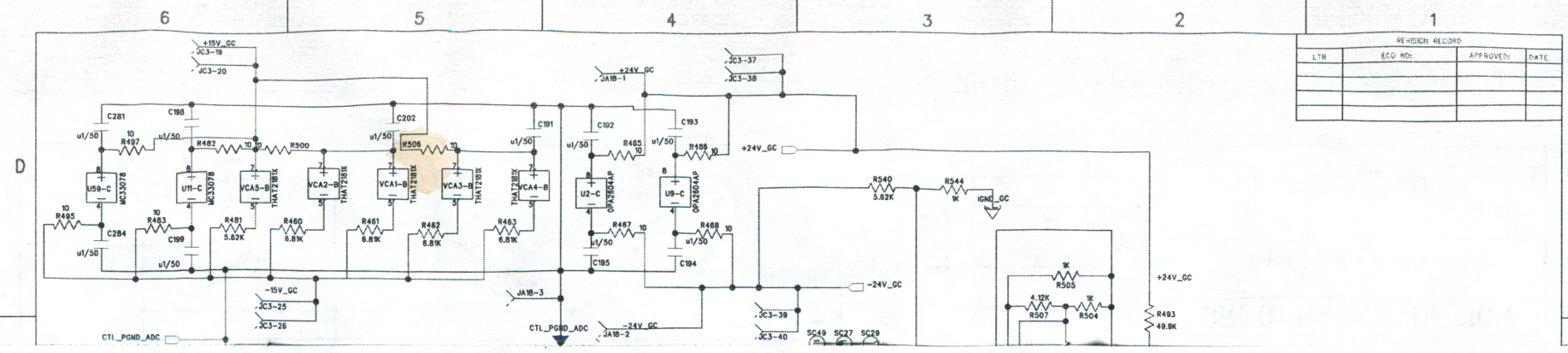

**GREG HANKS DESIGN**

FILE: **Alternate Gain Cell**

|                            |                      |        |       |                    |          |
|----------------------------|----------------------|--------|-------|--------------------|----------|
| DRAWN:                     | DATE:                | CODE:  | SIZE: | UNAWR'D NO.:       | REV.:    |
| CHECKED: <b>GH</b>         | DATE: <b>11-3-13</b> |        |       | BA-660 1003-9-2014 | 5-4      |
| QUALITY CONTROL: <b>GH</b> | DATE: <b>11-3-13</b> |        |       |                    | <b>0</b> |
| RELEASED:                  | DATE:                | SCALE: |       | SHEET: 1 OF 13     |          |

16/16