

**installation  
and  
operating  
instructions  
for model S-38  
radio receiver**

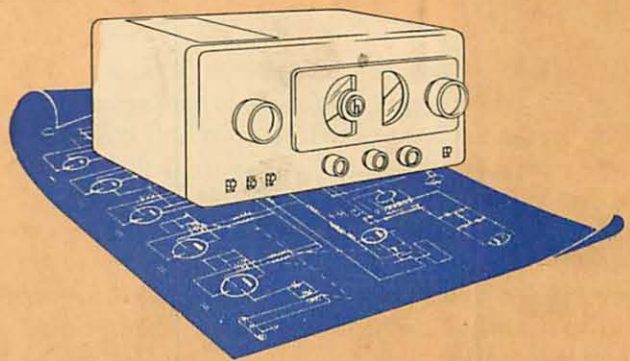

**AUGUST, 1946**

**94-162-A**

**the hallicrafters co.**

MANUFACTURERS OF RADIO AND ELECTRONIC EQUIPMENT, CHICAGO 24, U. S. A.



**INSTALLATION AND OPERATING  
INSTRUCTIONS  
FOR  
RADIO RECEIVER MODEL S-38**



*Figure 1. Radio Receiver Model S-38, front view.*

### DESCRIPTION

**GENERAL.**—The Model S-38 is a table model, six tube superheterodyne radio receiver capable of receiving standard broadcast and foreign or domestic short wave stations over four frequency ranges with continuous coverage provided from 540 kc (kilocycles) to 32 mc (megacycles). A bandswitch is provided for selecting the four ranges of reception which are indicated on the main tuning dial scale. The amateur bands are also clearly indicated on the main tuning dial scale as reference for the radio amateur. A bandspread dial is provided for fine tuning of short wave stations, the use of which is described later in these instructions. Special features are provided to improve reception such as volume control and noise limiter. Provision is made for the optional use of a headset. A beat frequency oscillator is provided for rendering code signals intelligible, this feature being especially useful to radio amateurs and code enthusiasts.

This receiver is designed to operate from a 117-volt a-c/d-c source and requires 30 watts of power. Connection to the power source is made by the two prong plug which is attached to the six foot line cord extending from the rear of the cabinet.

A special external resistance line cord can be supplied on request for operation on 220 to 250 volts a-c or d-c.

The complete receiver is  $12\frac{7}{8}$  inches wide by  $7\frac{3}{8}$  inches high by  $8\frac{5}{8}$  inches deep and weighs 10 pounds.



The maximum audio output of the receiver at the speaker is 0.8 watt with less than 10 per cent distortion.

**MECHANICAL DESCRIPTION.**—The Model S-38 radio receiver is housed in a well ventilated sheet metal cabinet to minimize electrical interference and provide mechanical strength. Access to the top of the chassis may be had without removing the chassis from the cabinet. Mixer and oscillator trimmer adjustments may be made from the bottom of the cabinet through the holes provided for this purpose under the notice card. Two holes on the bottom near the front of the cabinet are provided for oscillator padder adjustments. All controls for tuning and operating the receiver are located on the front of the receiver.

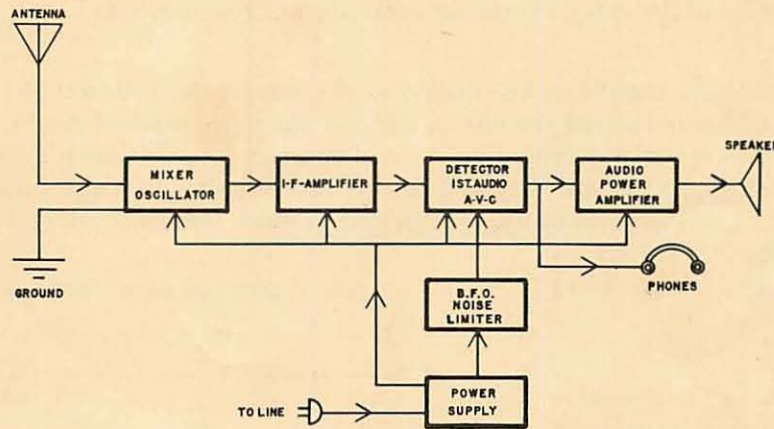

**Figure 2. Radio Receiver Model S-38, block diagram showing receiver circuits.**

**ELECTRICAL DESCRIPTION.**—The block diagram (Fig. 2) illustrates the function of the receiver circuits in a simple manner which is described as follows: Radio signals are picked up at the antenna and fed to the antenna coil of the mixer stage where the desired station signal is selected by a resonant circuit and fed to the mixer tube. At the same time, the oscillator section of the tube generates a local r-f signal which is mixed with the incoming station signal. An intermediate frequency signal of 455 kc (kilocycles) is selected by the first i-f transformer and fed to the i-f amplifier tube where it is amplified and then fed through the second i-f transformer to the detector-first audio amplifier tube where it is demodulated. The audio component of the signal is then amplified by the triode section of the tube and capacity coupled to the audio power output tube where it is further amplified and fed to the speaker.

The a-v-c circuit is a conventional one and provides stability when listening to music or voice (phone) broadcasts. It is in use when the AM/CW switch is in the AM position.

The beat frequency oscillator stage operates in the CW position of the AM/CW switch and provides an r-f signal at 455 kc (kilocycles) which is fed to the detector stage to beat against the i-f signal, thereby rendering code signals intelligible. The pitch of the code signal can of course be varied by means of the CW PITCH control which will permit a variation from 0 to 1,000 cycles.

A rectifier stage provides a well filtered source of high voltage to the plate and screen circuits when the receiver is operated from an a-c source.



## INSTALLATION AND OPERATION

### INSTALLING THE RECEIVER.—

1. As soon as the receiver has been unpacked, examine it for any apparent damage which might have occurred in shipment. If any damages are found, file a claim IMMEDIATELY with the transportation company. If purchased "over the counter", examine thoroughly for any possible visible defects, BEFORE ACCEPTANCE.

2. This receiver is equipped with rubber mounting feet for mounting on a table or other piece of furniture. Do not mount this radio on a radiator, gas stove or other area subject to excessive heat or humidity. Metal surfaced areas are not recommended.

3. An external antenna should be connected to the receiver as follows: On the rear apron of the receiver chassis is located the antenna connector strip, marked A1, A2, and G. Select one of the antenna systems described below and connect it to this strip as directed. An external ground connection is not essential to this receiver, but in some locations will give better reception. If it is desired to use an external ground, always connect it to the terminal on the strip marked "G"; NEVER connect it directly to the receiver chassis.

**A. Single Wire Antenna.—**When using a single wire antenna installation, connect a jumper between the antenna terminals A2 and G. Then connect a single wire antenna of about 50 to 75 feet (including lead-in) to terminal A1. Use #14 (AWG) or heavier wire for best results. Erect the antenna as high and free from surrounding objects as possible. This type of antenna works well where the signal to noise ratio is relatively high and a more elaborate installation is not practical.

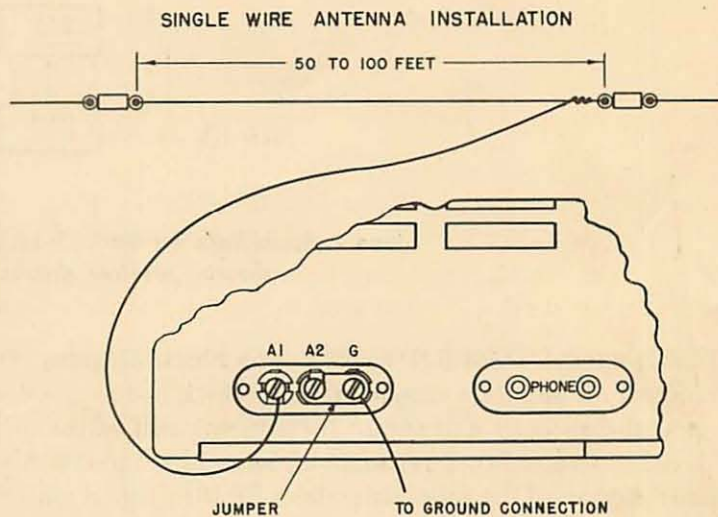

Figure 3. Single Wire Antenna Installation.

**B. Doublet Antenna.—**The doublet antenna is recommended where the receiving conditions are poor or where maximum sensitivity is required over a relatively narrow range of frequencies. The lead-in wires from the antenna are then connected to terminals A1 and A2. If a concentric line with grounded outer conductor is used, connect the inner conductor to terminal A1, the outer conductor to A2 and connect a jumper between terminals A2 and G.

- (1). To determine the proper length of the doublet antenna in feet:
  - (a) Determine the frequency range to which you wish to listen.
  - (b) Divide 468 by the frequency (in megacycles) of the high frequency end of the range you selected.
- (2) To prepare the antenna for installation:



(a) Measure the wire to the length determined in step (b) above cut exactly in half then insert insulator at that point.

(b) Wrap and solder the two wires of the lead-in to each of the quarter-wave sections at the insulator as shown in Figure 4.

Keep in mind that this type of antenna is directional broadside to its length and should be so orientated if maximum pick-up from a given direction is desired. For reference to other types of antennae refer to the latest edition of the A.R.R.L. Radio Amateur Handbook, section on antennas.

**HEADSET RECEPTION.**—Phone tip jacks located at the rear of the receiver chassis are provided for headset reception.

A high impedance headset is recommended for use with this receiver. When headset reception is desired, insert the cord tips into the PHONES jacks and set the SPEAKER-PHONES switch at PHONES.

**EXPLANATION OF THE RECEIVER CONTROLS.**—Scanning across the front of the receiver from left to right the controls and an explanation of each is as follows:

**NOTE.** Some of the control markings are in RED. This is an added feature incorporated for the convenience of the listener who is not familiar with radio terminology as an aid in setting the controls most used for the reception of standard broadcast stations.

Reference to Figure 5 will help in becoming familiar with the use of the controls.

**IF HUM IS PRESENT** when operating the receiver from an a-c source of power, reverse the line cord plug in the power outlet. If this does not remove the hum, then it is recommended that a good ground be connected to the ground terminal at rear of receiver.

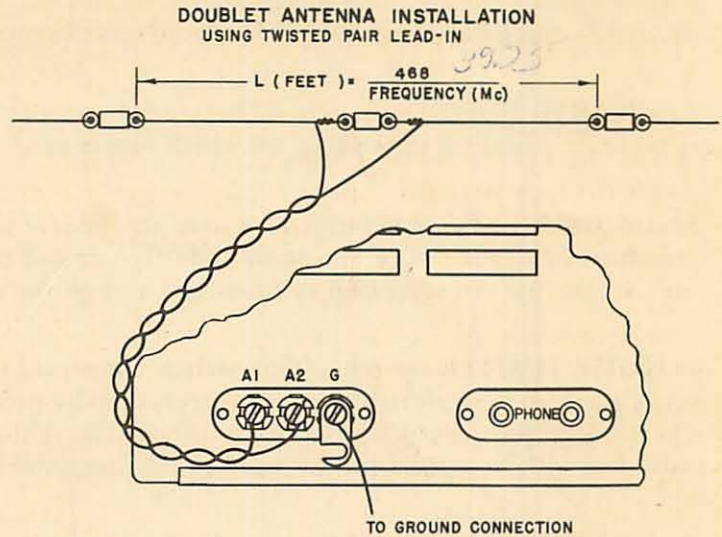

Figure 4. Doublet Antenna Installation.

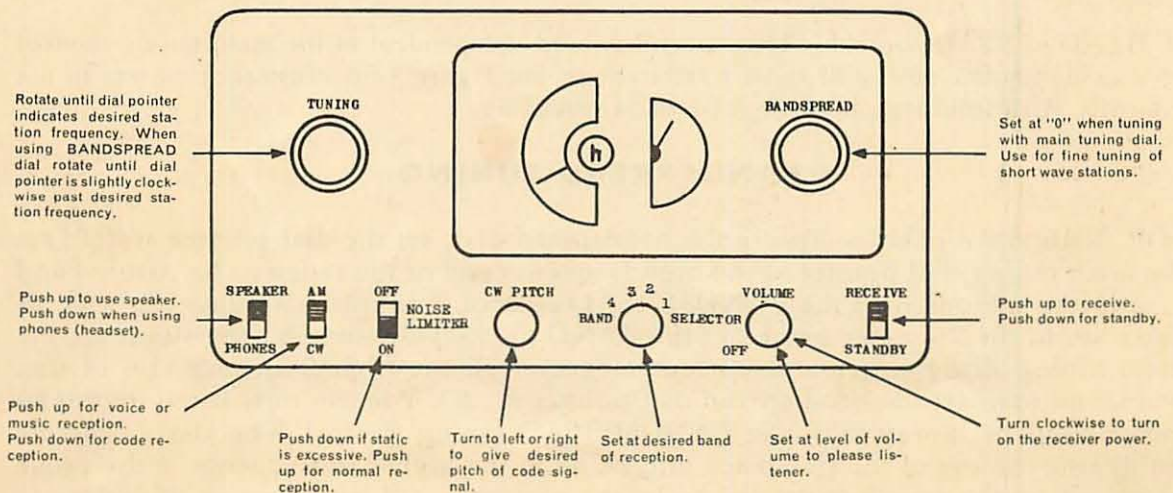

Figure 5. Radio Receiver Model S-38, view showing use of controls.



1. **TUNING.**—This control tunes the receiver to the frequency of the desired station which is read directly on the main tuning dial scale, located to the right of the control, and is indicated by the RED pointer when the bandspread pointer is set at "0".
2. **SPEAKER-PHONES switch.**—This switch connects the output of the receiver to the speaker or a headset depending on which one is used.
3. **AM/CW switch.**—This switch is used to connect the beat frequency oscillator into the detector circuit for the reception of code signals and to connect the automatic volume control circuits for the reception of broadcast and phone stations.
4. **NOISE LIMITER switch.**—This switch connects a circuit which clips the noise voltage peaks generated by electrical disturbances, thereby providing intelligible reception in cases where reception would normally be impossible. This feature will not totally remove the noise but will do a good job of limiting it to reasonable levels.
5. **CW PITCH control.**—This control varies the inductance of the beat frequency oscillator coil thereby providing a means of varying the pitch of the code signals from 0 to 1,000 cycles depending on the listener's discretion.
6. **BAND SELECTOR switch.**—This switch selects one of the four bands or frequency ranges available to the listener. The frequencies covered by each band switch position are read directly from the main tuning dial scale.
7. **VOLUME control.**—This control regulates the audio signal level at the speaker or headset and should be set to a position which will provide a level of volume most pleasing to the listener. Ganged to this control is the receiver power switch which connects the power to the receiver when the control is turned clockwise.
8. **RECEIVER-STANDBY switch.**—This switch disconnects the d-c voltage from the receiver while leaving the tube heaters at operating temperature, thus leaving the receiver in condition for instant use. This switch is used by the radio amateur "ham" to put the receiver in a standby condition when transmitting. For the general listener it provides a means of putting the receiver in an operative condition ready for instant use.
9. **BAND SPREAD control.**—This control is used independent of the main tuning control to provide for fine tuning of short wave stations. See Figure 5 for illustration on use of the controls. Also following paragraph on band spreading.

### **BANDSPREAD TUNING**

**FOR THE AMATEUR.**—To use the bandspread dial, set the dial pointer at "0", set the main tuning dial pointer at the high frequency end of the range to be covered and tune in the stations with the BANDSPREAD control. Example:—Assume you wish to listen in on the 20 meter band. Set the BAND SELECTOR switch as position #3, the main tuning dial pointer at 14.4 mc (megacycles), the high frequency end of that band, and then set the band spread dial pointer at "0". You can now listen on the 20 meter band by tuning with the BANDSPREAD tuning control. The above example holds true for any of the frequency ranges, altho the higher in frequency is the range of tuning on the main tuning dial scale, the narrower will be the range of tuning on the bandspread tuning dial scale. Bandspread tuning is not necessary on the broadcast band (Position #1 of the BAND SELECTOR switch).



**FOR THE SHORT WAVE LISTENER.**—To tune in short wave broadcast radio stations with the bandsread dial, set the bandsread dial pointer at "0", set the main tuning dial pointer slightly clockwise past the frequency of the station you wish to tune in and then tune in the station with the **BANDSPREAD** tuning control.

**IMPORTANT.**—The calibrations on the main tuning dial scale are only correct when **BAND SPREAD** dial pointer is set at "0".

## OWNER'S MAINTENANCE

**PREVENTIVE MAINTENANCE.**—Keep the various parts of the receiver clean, especially the tuning capacitors. Dust and dirt should be blown out with dry air or brushed out carefully without bending the capacitors plates in the slightest. Noisy reception may be also caused by dirty condensers wipers, faulty volume controls, switches and tubes, etc., in the receiver. Check switch contacts and controls and make sure that all tubes are always in their sockets.

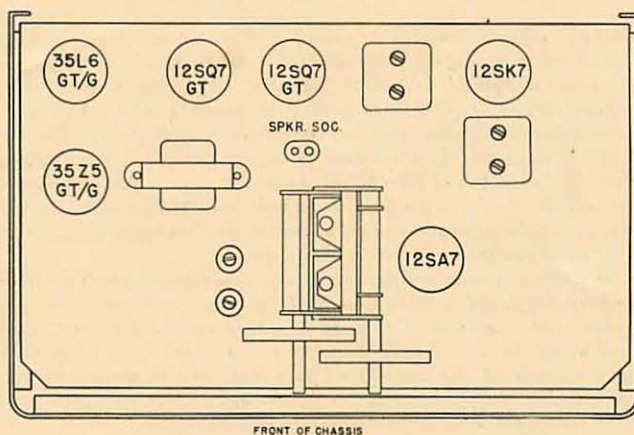

Figure 6. Radio Receiver Model S-38, view showing tube locations.

**REPLACING THE TUBES AND DIAL LAMP.**—It will be necessary to remove the fiber back cover of the receiver in order to replace tubes and dial lamp. This can be accomplished by removing the two rear screws on the bottom plate and then removing the four screws which hold the cover to the cabinet. When replacing tubes, check the tube type carefully and replace with the correct type. Refer to the top view of the receiver chassis, Fig. 6, to determine the location of each tube. The receiver employs one dial lamp with bayonet type socket to illuminate the two dial scales. Replace this lamp with smaller type, 6.8 volt, 150 ma. "brown bead" G.E. #47 or equivalent. The color code referred to is the color of the glass bead above the glass stem inside the envelope of the lamp.

**PERIODIC ADJUSTMENTS.**—This receiver has been carefully aligned at the factory and should not require realignment until it requires new tubes in the mixer-oscillator stage or shows signs of loss in sensitivity, off frequency calibration or requires service work on this stage. Alignment should not be attempted by inexperienced persons as maximum performance is obtained only by intelligent alignment.



## Warranty

*The Hallicrafters Company warrants each new radio product manufactured by it to be free from defective material and workmanship and agrees to remedy any such defect or to furnish a new part in exchange for any part of any unit of its manufacture which under normal installation, use and service discloses such defect, provided the unit is delivered by the owner to our authorized radio dealer or wholesaler from whom purchased, intact, for our examination with all transportation charges prepaid within ninety days from the date of sale to original purchaser and provided that such examination discloses in our judgment that it is thus defective.*

*This warranty does not extend to any of our radio products which have been subjected to misuse, neglect, accident, incorrect wiring not our own, improper installation, or to use in violation of instructions furnished by us, nor extend to units which have been repaired or altered outside of our authorized facilities, nor to cases where the serial number thereof has been removed, defaced or changed, nor to accessories used therewith not of our own manufacture.*

*Any part of a unit approved for remedy or exchange hereunder will be remedied or exchanged by the authorized radio dealer or wholesaler without charge to the owner.*

*This warranty is in lieu of other warranties expressed or implied and no representative or person is authorized to assume for us any other liability in connection with the sale of our radio products.*



# the hallicrafters co.

## SERVICE BULLETIN No. 2 FOR MODEL S-38

**GENERAL:** Model S-38 is a 6 tube AC/DC superheterodyne table model, radio receiver, incorporating 4 bands of AM/CW reception, as follows: band #1, 540 kc to 1650 kc; band #2, 1650 kc to 5.0 mc; band #3, 5.0 mc to 14.5 mc; band #4, 13.5 mc to 32.0 mc. Provision for AVC, noise limiting, BFO pitch, headset reception, standby operation, and bandspreading are provided.

**REAR PANEL CONNECTIONS:** Consist of line cord with plug, antenna and ground connector strip, and headset connector plug strip.

**POWER SUPPLY DATA:** 105 to 125 volts AC/DC line voltage. Power drain is 30 watts.

**TUBE TYPES AND FUNCTION:** 12SA7—mixer-oscillator; 12SK7—IF amplifier; 12SQ7GT—detector, AVC, audio amplifier; 35L6GT—audio power amplifier; 12SQ7GT—BFO and ANL; 35Z5GT—power rectifier for AC operation.

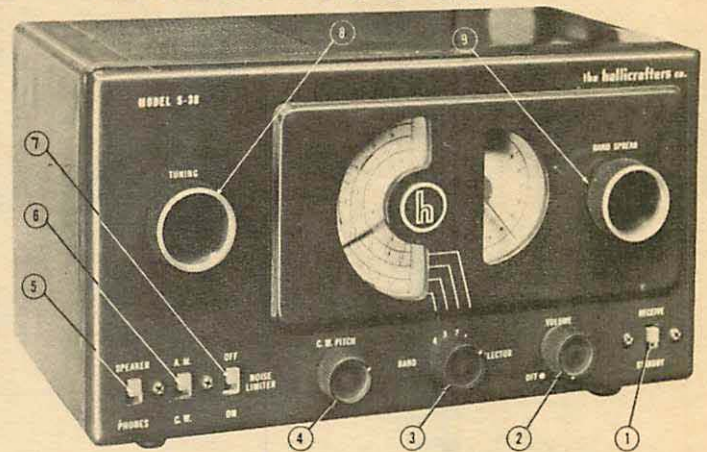

Fig. 1. Front view of receiver showing control locations.

### DETAILED SERVICE INFORMATION

IF FREQUENCY	IF SELECTIVITY	IMAGE RATIO	SENSITIVITY	AUDIO OUTPUT
455 kc	7 kc wide at 6 db down 65 kc wide at 60 db down (for 50 milliwatt output)	2.7:1 at 30 mc 6:1 at 14 mc 10:1 at 5 mc 35:1 at 1500 kc	12 microvolt at 600 kc 12 microvolt at 5 mc 11 microvolt at 14 mc 23 microvolt at 30 mc (for 50 milliwatt output)	675 milliwatt with less than 10% distortion at 400 cycles

### CONTROL SETTINGS FOR PRELIMINARY TEST OPERATION (Broadcast Band)

REF. NO. (in Fig. 1)	NAME	FUNCTION	SETTING	REF. NO. (in Fig. 1)	NAME	FUNCTION	SETTING
1	STANDBY/ RECEIVE	Receiver temporary standby	At "RECEIVE"	5	SPEAKER/ PHONES	Output selector switch	At "SPEAKER"
2	VOLUME	Audio gain control and receiver on/off switch	Half clockwise; adj. as necessary	6	CW/AM	BFO on/off switch AVC on/off switch	At "AM" (AVC on)
3	BAND SELECTOR	Operating band selector	Clockwise to "1"	7	NOISE LIMITER	Noise peak limiting	At "OFF"
4	PITCH CONTROL	CW beat note pitch selector	Any position (not in use)	8	TUNING	Main tuning control	To local station freq. on main dial scale
				9	BAND SPREAD	Short wave band spreading	To "0" on small dial scale

### HOW TO RESTRING DIAL CORDS

To restring the main tuning dial cord, cut a 14" length of 30 lb. test dial cord and tie one end to the tension spring of the main tuning capacitor drive pulley at position "1" on the diagram. Following the numbers 1 through 15, wind the cord on the pulley and knob drive shaft. At position "15," stretch the tension spring and tie the cord securely. Cut off the excess cord. Note that two complete turns are wound on the knob drive shaft.

To restring the bandspread tuning dial cord, cut a 16" length of dial cord and follow the procedure as explained above, except start at position "A" on the diagram and proceed through position "S." Note that the knob drive shaft has two complete turns.

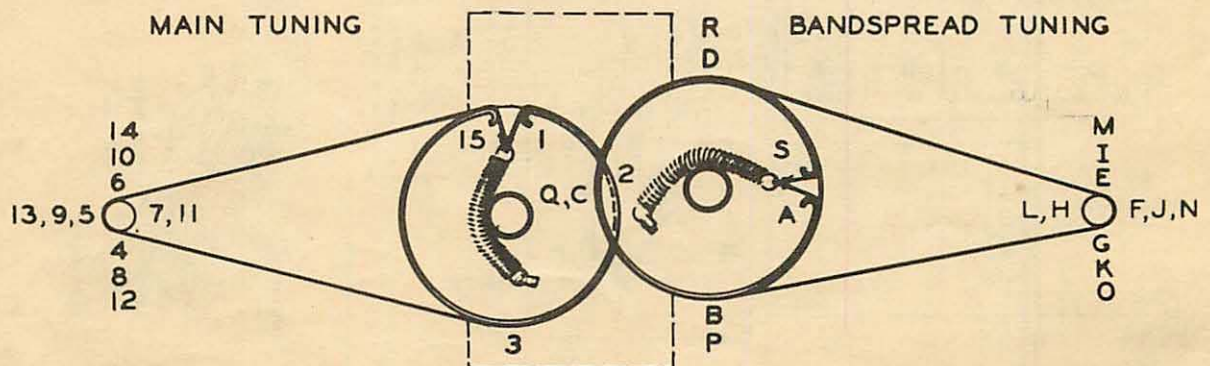

TUNING CAPACITOR FULLY CLOSED (BOTH SECTIONS).  
FRONT VIEW

Fig. 2. Dial cable stringing procedure.



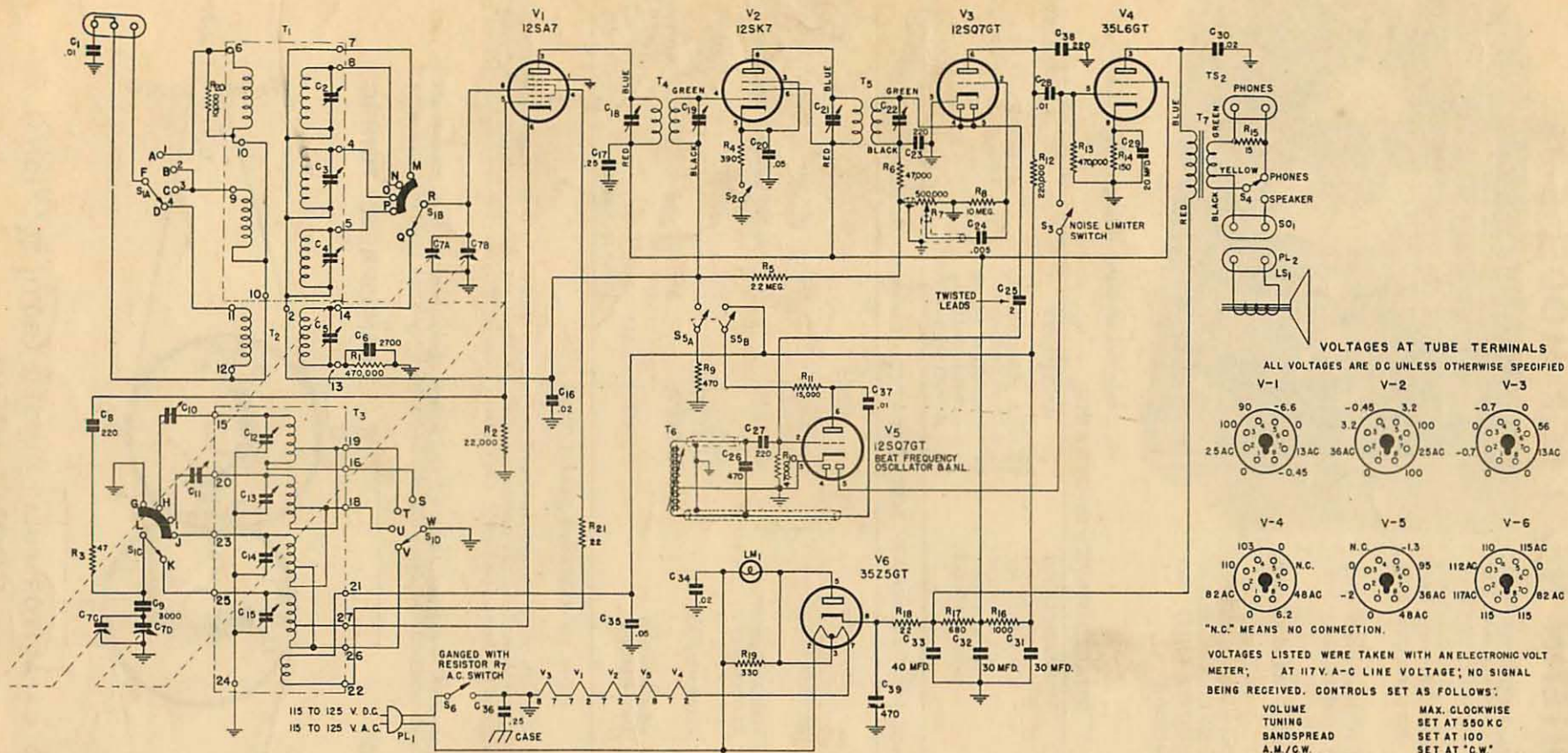

VOLTAGES AT TUBE TERMINALS  
ALL VOLTAGES ARE DC UNLESS OTHERWISE SPECIFIED

V-1	V-2	V-3
90 -0.6	-0.45 3.2	-0.7 0
100 0.0	3.2 100	0 56
25 AC 0.0	0 136 AC	-0.7 13 AC
0 -0.45	0 100	0 0

V-4	V-5	V-6
103 0	N.C. -1.3	110 115 AC
110 0	95 0	112 AC 0
82 AC 0	-2 0	36 AC 117 AC
0 6.2	0 48 AC	115 115

"N.C." MEANS NO CONNECTION.

VOLTAGES LISTED WERE TAKEN WITH AN ELECTRONIC VOLT METER, AT 117 V. A-C LINE VOLTAGE, NO SIGNAL BEING RECEIVED, CONTROLS SET AS FOLLOWS:

VOLUME	MAX. CLOCKWISE
TUNING	SET AT 550 KC
BANDSPREAD	SET AT 100
A.M./C.W.	SET AT 'C.W.'
RECEIVE/STANDBY	SET AT 'RECEIVE'
NOISE LIMITER	SET AT 'OFF'
BAND SELECTOR	SET AT '1'
SPEAKER/PHONES	SET AT 'SPEAKER'

NOTE: RESISTANCE VALUES ARE IN OHMS; MICA CAPACITOR VALUES ARE IN MMF; PAPER CAPACITOR VALUES ARE IN DECIMAL EQUIVALENTS OF MFD; ELECTROLYTIC CAPACITOR VALUES ARE IN MFD.

--- DENOTES ELECTRICAL SHIELD.  
- - - DENOTES UNSHIELDED UNIT ASSEMBLY.  
--- DENOTES MECHANICAL GANGING.

LETTERS AT BANDSWITCH (S1) AND NUMERALS AT ANTENNA AND OSCILLATOR TRANSFORMERS (T1, T2 & T3) IDENTIFY CORRESPONDING TERMINAL LUGS ON PICTORIAL VIEWS.

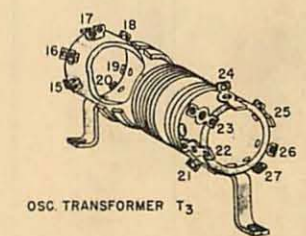
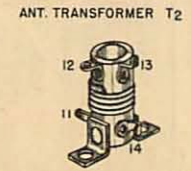
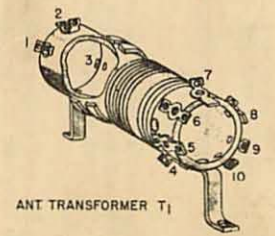
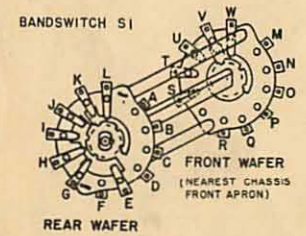

NOTE: DIMENSIONS & PROPORTIONS SHOWN IN PICTORIAL VIEWS HAVE BEEN EXAGGERATED FOR CLARITY OF TERMINAL LUG LOCATION.

89D204J

Fig. 3 Schematic diagram including tube terminal voltages and pictorial views of bandswitch, mixer and oscillator coil forms for terminal lug location and cross reference to the schematic.



## REPLACEMENT PARTS

REF. NO.	DESCRIPTION	HALLICRAFTER'S PART NUMBER	LIST PRICE PER COMPONENT	REF. NO.	DESCRIPTION	HALLICRAFTER'S PART NUMBER	LIST PRICE PER COMPONENT
<b>CAPACITORS</b>				<b>SWITCHES</b>			
C-1	0.01 mfd; 600 vdcw; paper	46AY103J	\$.10	S-1a, b, c & d	Bandswitch; two sections ganged; rotary four position	60A240	\$.95
C-2, 3 & 4	Trimmer Unit for antenna transformer T-1	44B129	.40	S-2 & 3	"RECEIVE-STANDBY" and "NOISE LIMITER" switches; slide action; SPST	60A244	.20
C-5	Trimmer for antenna transformer T-2	44A039	.10	S-4	"SPEAKER-PHONES" switch; slide action; SPDT	60A243	.20
C-6	2700 mmf; ± 5%; 500 vdcw; mica	CM30A272J	.30	S-5	"A.M.-C.W." switch; slide action; DPST	60A245	.25
C-7	Tuning capacitor; air; 2 sections ganged	48C162	2.90	<b>TRANSFORMERS</b>			
C-8, 23, 27 & 38	220 mmf; 500 vdcw; mica	CM20A221K	.15	T-1	Antenna coil for bands 1, 2 and 3	51C821	2.35
C-9	3000 mmf; 5%; 500 vdcw; mica	CM30A302J	.65	T-2	Antenna coil for band 4	51C818	.65
C-10 & 11	Dual padder for oscillator transformer T-3	44A152	.50	T-3	Oscillator coil for bands 1, 2, 3 and 4	51C822	2.45
C-12, 13, 14 & 15	Trimmer Unit for oscillator transformer T-3	44B159	.50	T-4	Input IF transformer; 455 kc	50C183	1.20
C-16 & 34	0.02 mfd; 400 vdcw; paper	46AW203J	.10	T-5	Diode IF transformer; 455 kc	50B184	1.20
C-17 & 36	0.25 mfd; 200 vdcw; paper	46AT254J	.15	T-6	Beat frequency oscillator coil; 455 kc	54B031	1.25
C-18, 19, 21 & 22	Trimmers for IF transformers T-4 and T-5	44A097	.25	T-7	Audio output transformer; 3,000 ohm primary —15 ohm secondary tapped at 3 ohms	55A075	.95
C-20 & 35	0.05 mfd; 200 vdcw; paper	46AU503J	.10	<b>TERMINAL STRIPS</b>			
C-24	0.005 mfd; 400 vdcw; paper	46AW502J	.10	TS-1	Antenna and ground connector strip	88A032	.10
C-25	2 mmf; twisted insulated wire leads; NOT AVAILABLE AS A SPARE PART.			TS-2	Headset plug connector strip; bakelite	88A071	.10
C-26 & 39	470 mmf; 500 vdcw; mica	CM20A471K	.20	<b>MISCELLANEOUS MECHANICAL COMPONENTS</b>			
C-28 & 37	0.01 mfd; 400 vdcw; paper	46AW103J	.10	QUANT. IN EQUIPMENT	DESCRIPTION	HALLICRAFTER'S PART NUMBER	LIST PRICE PER COMPONENT
C-29, 31, 32 & 33	Electrolytic; four section unit; color coded leads; sect. 1(C-29) 20 mfd, 25 vdcw; sect. 2 & 3(C-31 & 32) 30 mfd, 150 vdcw; sect. 4(C-33) 40 mfd, 150 vdcw	45B091	.80	2	Knob; for Volume Control and Band Selector switches	15A049	.15
C-30	0.02 mfd; 600 vdcw; paper	46AY203J	.10	1	Knob; for C. W. PITCH Control	15A058	.15
<b>PILOT LAMP</b>				1	Knob; for main TUNING and BANDSPREAD tuning Controls	15A047	.25
LM-1	6/8 v @ 150ma; brown bead; G. E. type 47	39A004	.10	1	Pointer; for main tuning dial	82A102	.15
<b>LOUDSPEAKER</b>				1	Pointer; for bandspread tuning dial	82A103	.15
LS-1	5" P.M. speaker; 3.2 ohm voice coil	85C035	2.50	1	Calibrated dial assembly, complete	83B257	.15
<b>PLUGS</b>				1	Dial window; glass	22B157	.30
PL-1	AC line cord with two prong plug at one end	87A078	.35	6	Octal tube sockets; Amphenol type MIP-8	6A035	.10
PL-2	Speaker voice coil connector plug	88A072	.10	1	Dial lamp socket; bayonet	86A011	.15
<b>RESISTORS</b>				1	Tuning capacitor dial drive pulley	28A002	.10
R-1 & 13	470,000 ohm; ½ watt; carbon	RC20AE474M	.10	1	Tuning capacitor rear mounting bracket	67A568	.10
R-2	22,000 ohm; ½ watt; carbon	RC20AE223M	.10	1	Tuning capacitor front mounting bracket	67A559	.15
R-3	47 ohm; ½ watt; carbon	RC20AE470M	.10	1	Left hand switch mounting bracket	67B560	.10
R-4	390 ohm; ± 10%; ½ watt; carbon	RC20AE391K	.10	1	Right hand switch mounting bracket	67B561	.10
R-5	2.2 megohm; ½ watt; carbon	RC20AE225M	.10	4	Rubber mounting feet for cabinet	16A007	.10
R-6 & 10	47,000 ohm; ½ watt; carbon	RC20AE473M	.10	2	Spring washers for grounding tuning capacitor drive shafts	4A043	.10
R-7 & S-6	Volume Control; ½ megohm; includes SPST toggle action switch assembly on rear	25B094	.50	4	"C" washers; (hair-pin type)	75A062	.10
R-8	10 megohm; ½ watt; carbon	RC20AE106M	.10	1	Rear cover plate; cardboard	32C331	.10
R-9 & 11	470 ohm; ± 10%; ½ watt; carbon	RC20AE471K	.10	1	Bottom cover plate; painted steel	63C220	.45
R-12	220,000 ohm; ½ watt; carbon	RC20AE224M	.10	<b>NOTE: ALL PRICES ARE SUBJECT TO CHANGE WITHOUT NOTICE.</b>			
R-14	150 ohm; ± 10%; ½ watt; carbon	RC20AE151K	.10	Explanation of abbreviations: mmf—micromicrofarads; mfd—microfarads; vdcw—DC working volts; v—volts; ma—milliamperes; IF—intermediate frequency; sect.—section; REF. NO.—circuit symbol as on the schematic diagram.			
R-15	15 ohm; ½ watt; carbon	RC20AE150M	.10				
R-16	1,000 ohm; ½ watt; carbon	RC20AE102M	.10				
R-17	680 ohm; 1 watt; carbon	RC30AE681M	.10				
R-18 & 21	22 ohm; ½ watt; carbon	RC20AE220M	.10				
R-19	330 ohm; ½ watt; carbon	RC20AE331M	.10				
R-20	10,000 ohm; ½ watt; carbon	RC20AE103M	.10				
<b>PILOT LAMP</b>							
<b>LOUDSPEAKER</b>							
<b>PLUGS</b>							
<b>RESISTORS</b>							

NOTE: Mica dielectric capacitors have a tolerance of ± 10% unless otherwise specified; paper dielectric capacitors tolerance is -10 +40%; carbon resistors have a tolerance of ± 20% unless otherwise specified.

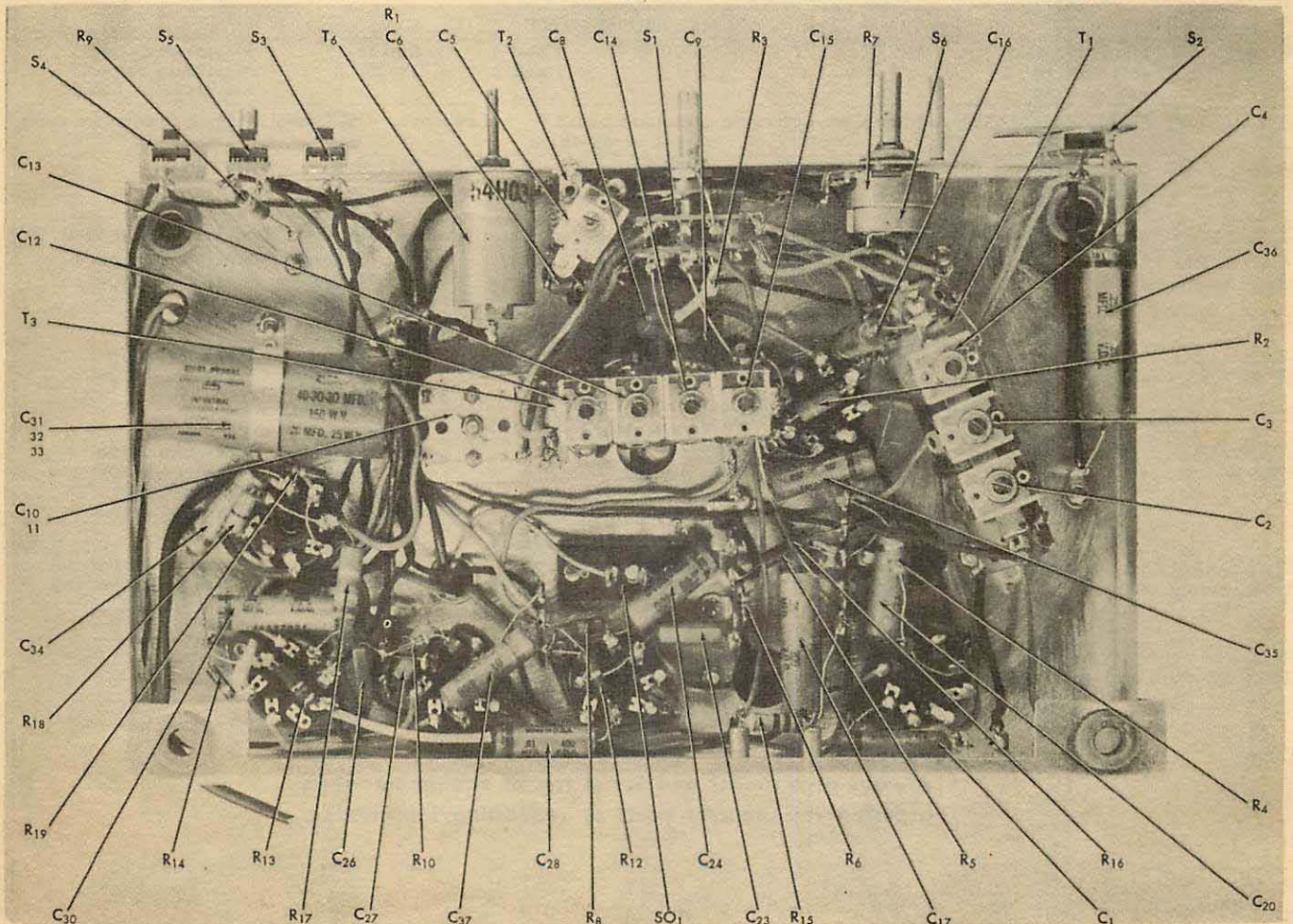

Fig. 4. Bottom view of the receiver showing components location.



# ALIGNMENT INSTRUCTIONS

## EQUIPMENT:

1. Signal Generator capable of the ranges indicated in the Alignment Chart, including a 400 cycle audio modulator.
2. Output meter capable of handling 1 watt of audio power.
3. Standard RMA dummy consisting of a 200 mmf condenser in series with a 20uh r-f choke which is shunted by a 400 mmf condenser in series with a 400 ohm carbon resistor.
4. Non-metallic screw driver.

**CONNECTIONS:** Connect the Sig. Gen. "cold" lead to "G" on the antenna strip; the "hot" lead is connected as indicated in the Chart.

Connect the output meter across the terminals of socket SO-1 and remove the speaker plug from the socket and adjust the meter for 3 ohms impedance.

Caution: Set the meter at a sufficiently high range to prevent possible damage from overload.

**CONTROL SETTINGS:** After allowing about a ten minute warm up period, set the receiver's control as follows:

- SPEAKER/PHONES switch at "SPEAKER."
- VOLUME control at full clockwise (maximum).
- CW/AM switch at "AM" (except for BFO adjustment).
- NOISE LIMITER switch at "OFF."
- BANDSPREAD TUNING control at "0," (min. cap.).
- STANDBY/RECEIVE switch at "RECEIVE."

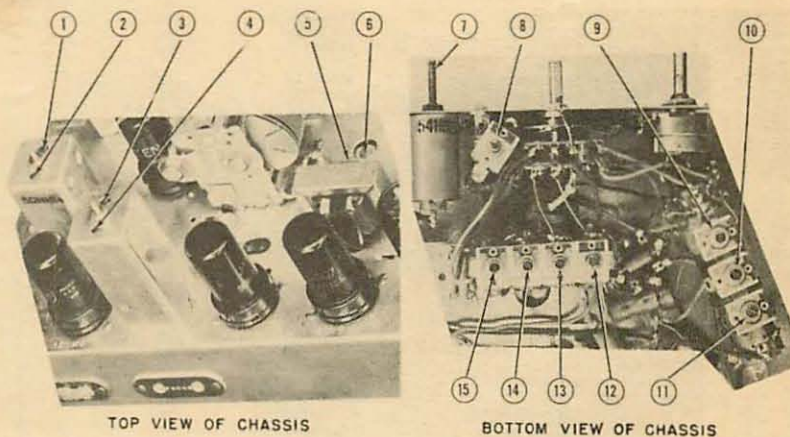

Fig. 5. Top and bottom views of the receiver locating slugs, padders and trimmers for alignment purposes.

DUMMY ANT. IN SERIES WITH SIG. GENERATOR	CONNECTION OF SIG. GENERATOR OUTPUT TO RECEIVER	SIG. GEN. FREQUENCY SETTING	BAND SWITCH SETTING	RECEIVER DIAL SETTING	ADJUST SLUG, PADDER, OR TRIMMER NO.	DESCRIPTION	TYPE OF ADJUSTMENT —MAKE ADJUSTMENT FOR:	STEP NO.
*IF ADJUSTMENT								
None	Stator plates of rear sect. of tuning gang	455 kc	"1"	1000 kc	3 and 4 1 and 2	2nd IF 1st IF	Maximum output Maximum output Repeat steps 1 and 2	1 2
BFO ADJUSTMENT—NOTE: Turn off Sig. Gen. 400 cycle modulation; set CW/AM switch at "CW"; remove Pitch Control knob and adjust slotted screw shaft.								
None	Stator plates of rear sect. of tuning gang	455 kc	"1"	1000 kc	7	BFO slug	Zero beat	3
BAND #4 ADJUSTMENT—NOTE: Make sure 400 cycle audio modulator is turned on; AM/CW switch should be at "AM."								
STANDARD	"A1" on antenna	30 mc	"4"	30 mc	12	Osc. Trimmer	Maximum output	4
RMA Dummy	strip	30 mc		30 mc	† 8	Mix. Trimmer	Maximum output	5
BAND #3 ADJUSTMENT								
STANDARD	"A1" on antenna	14 mc	"3"	14 mc	13	Osc. Trimmer	Maximum output	6
RMA Dummy	strip	14 mc		14 mc	† 9	Mix. Trimmer	Maximum output	7
*BAND #2 ADJUSTMENT								
STANDARD	"A1" on antenna	5 mc	"2"	5 mc	14	Osc. Trimmer	Maximum output	8
RMA Dummy	strip	1.8 mc		1.8 mc	6	Osc. Padder	Maximum output and repeat step 8	9
		5 mc		5 mc	†10	Mix. Trimmer	Maximum output	10
*BAND #1 ADJUSTMENT								
STANDARD	"A1" on antenna	1500 kc	"1"	1500 kc	15	Osc. Trimmer	Maximum output	11
RMA Dummy	strip	600 kc		600 kc	5	Osc. Padder	Maximum output and repeat step 11	12
		1500 kc		1500 kc	11	Mix. Trimmer	Maximum output	13

\*It may be necessary to repeat the indicated adjustments several times.

†Rock the main tuning capacitor slightly (turn back and forth) when making these adjustments.

## ATTENTION

Always give Model and Serial No. of equipment when ordering replacement parts or requesting information.