

GRAMPIAN • GOTHAM

Feedback Cutter System

Grampian Cutterhead . . .



Gotham Amplifier . . .

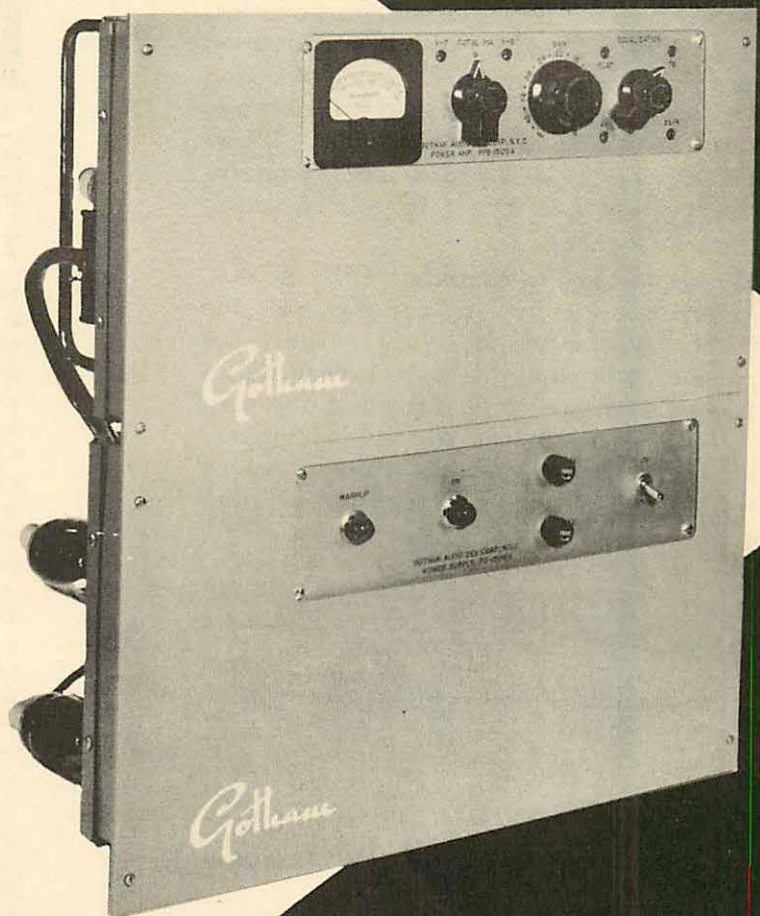

REEVES EQUIPMENT CORP.

10 East 52nd Street, New York 22, N. Y. • Plaza 9-7190

Cable address: Reevesquip

GRAMPIAN-GOTHAM

The GRAMPIAN-GOTHAM Feedback Recording System is a marvel of audio-engineering creativeness, producing the highest quality disc recordings known to date. Complete in every detail of equalization, pre-emphasis, and level correction for all three speeds, this unique system comes ready for instant mounting, turn-on, and operation without the necessity of recalibration, experimentation, etc. To operate the system requires only the sound source on one end and the lathe on the other.

It features the GRAMPIAN B1/AGU Feedback Cutterhead made in London, England; an improved version of the well-known BBC system. This superb cutterhead embodies an internal feedback winding which reduces distortion, flattens frequency response, and stabilizes operation over long periods of time and widely varying environmental conditions. Because it is damped through use of silicone damping fluid (Dow-Corning 200) with a leak-proof seal, temperature and age will not affect it, thus assuring constant performance.

The GOTHAM Recording Amplifier, PFB-150WA, is designed specifically to complement the GRAMPIAN Cutterhead in every respect. A masterpiece of precision, it is push-pull throughout for lowest even harmonic distortion and uses two 811-A Tubes as output triodes in conjunction with a toroidal output transformer which provides for low-distortion and transients during operation.

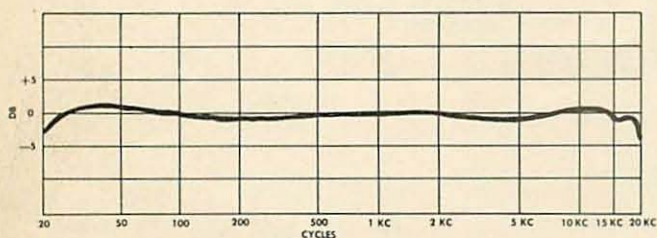
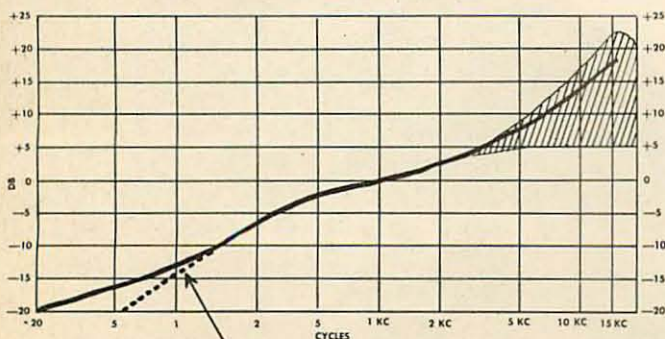

FIG. D BALANCED FM MODULATOR-DISCRIMINATOR CALIBRATION CHART OF AVERAGE CUTTER PERFORMANCE IN AIR.



THIS CURVE ON 78 RPM POSITION.

FIG. X RIAA CURVE ON 33 1/3, 45 AND 78 RPM POSITION.

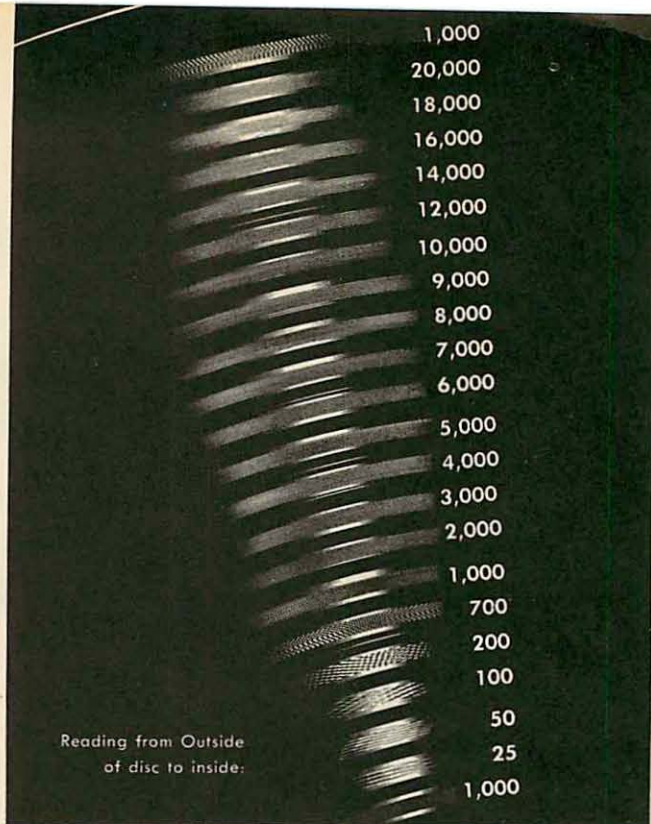

FIG. Y This is an unretouched photograph of a completely non-pre-emphasized GRAMPIAN Cutterhead with standard RIAA low-end droop. Buchmann-Meyer Patterns may be evaluated by keeping in mind that a pattern-width ratio of 2:1 indicates a level difference of 6 db.

THE RECORDING AMPLIFIER

To take full advantage of the maximum potential feedback offered by the cutter, Gotham has incorporated the feedback winding of the GRAMPIAN Cutterhead in the design of the Recording Amplifier. A front-located equalization control provides instant switching to any standard speed equalization, as well as a "Flat" position for testing the system. Also provided is individual screwdriver adjustment in each equalizing position, enabling precise adjustment of all curves to conform to the Standard RIAA curve (so adjusted at the factory), or to meet the individual requirements of the user, who prefers a slightly different equalization curve. The range of equalization adjustment is -10 db to +6 db at 15 KC, referring to the RIAA* curve in 33 1/3, 45 and 78 rpm positions (see Fig. X). Switching to the 78 rpm position automatically raises the overall level of the recording to correspond to present-day practices. The cutterhead's practically unlimited drive makes possible the highest level 78 rpm discs with full RIAA* pre-emphasis, consistent in every respect, and surpassing, the quality of today's top record manufacturers. The gain adjustment is a precision, detented control directly calibrated in 2 db steps.

The frequency response of the system is within 2 db of the RIAA* curve at all times and all levels, except in the "Flat" position where it is flat within 2 db from 30 cycles to beyond 15 KC. The high-torsion, pivotless, silicone-damped nature of the armature of the cutterhead makes it insensitive to mechanical loading so that the frequency response in air deviates less than 1 db from the frequency response in acetate. (This is best seen by observing the Balanced FM Modulator-Discriminator calibration chart of the cutter performance in air (see Fig. D) and the Buchmann-Meyer light pattern photo (see Fig. Y) of the same cutterhead. This behavior of the cutterhead is of tremendous advantage because acetate loading at various surface speeds, as well as different stylus-burnishing and heat conditions, no longer change the level or frequency response of the cutterhead. Of course, the playback losses due to small record diameters still exist.

* Recording Industry Association of America. The standard equalization to be used in disc recording adopted by this organization, comprised of all the major Recording Companies, and Record Manufacturers, has become the one unified standard to which almost everyone is adhering today.

THE CUTTERHEAD:

The Cutter is of the iron vane, balanced armature type. Simplicity of construction makes it a rugged device; there are no springs nor balances to get out of adjustment. Fig. 10 shows a cutaway view of the essential parts of the head.

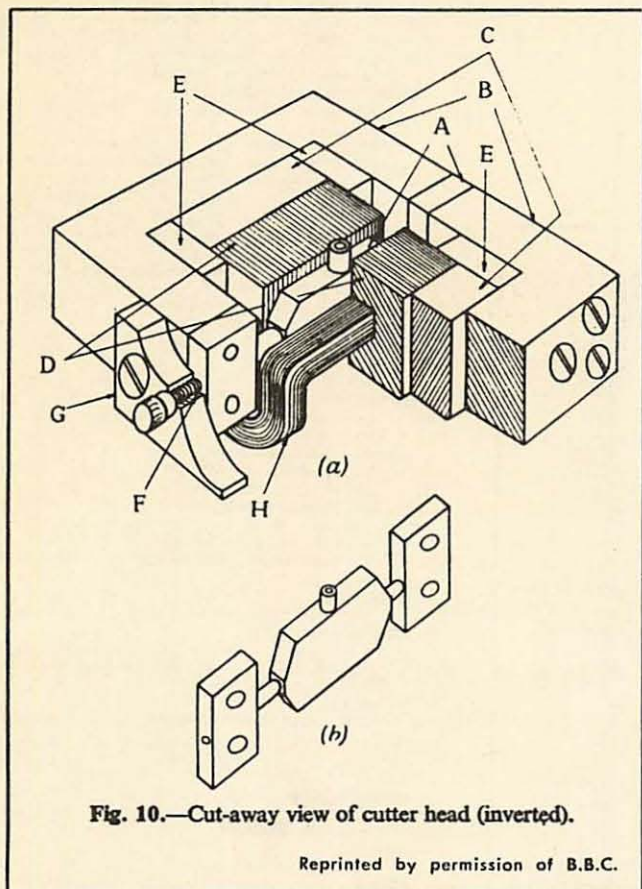

Fig. 10.—Cut-away view of cutter head (inverted).

The ends of the armature A (shown separately in Fig. 10) are clamped between two U-shaped steel yokes "B", within which lie two Ticonal magnets "C" and the laminated pole-pieces "D", with their brass clamping blocks "E". The metal at the bottom of the slots at either end of the armature is shaped to form torsion bars which support the active center portion of the armature in the gap between the pole pieces. To avoid trouble with non-axial deflections, these torsion bars are made as short as possible, consistent with reasonable stress at maximum excursion. Through the center of one of the torsion bars passes the long plain shank of the cutter clamping screw "F"; the thread is carried in an external block "G". The shank has a high torsional compliance so that the presence of the clamping screw does not add appreciably to the mechanical impedance of the armature. The coil "H" lies in the slots in the faces of the pole-pieces, and within the main winding is a second coil which is connected to the cathodes of the second stage of the GOTHAM PFB-150 WA amplifier, so as to provide negative feedback. The method of damping the mechanical resonance of the armature (around 10 KC) is to introduce a Silicone Damping Fluid into the air gaps between the armature "A" and the pole-pieces "D". Silicone is unique in

that it alone has the property of maintaining a constant viscosity over a wide temperature variation and length of service. Tests conducted with the cutter proved that the change in level covering a temperature range of 60°F. to 110°F. is no more than 1 db. Heating up of the drive coil, as well as heat transmission from a Thermo-Stylus assembly, had little or no effect.

The head will fit any standard lathe and is lightweight to reduce cutter bounce (marbleized effect on discs). The front plate cover is tapped to accommodate an adapter for use with heated stylus (sold as necessary) and the chuck fits standard short-shank styli.

TECHNICAL DATA

FREQUENCY RESPONSE

30 cycles to 15,000 cycles ± 2 db. Down no more than 4 db at 20 cycles and 20,000 cycles.

TOTAL RMS HARMONIC DISTORTION

Below 1% at 1000 cycles measured at 7 cm/sec. peak recorded velocity (NARTB Standard Level).

MATCHING IMPEDANCE

16 ohms.

D.C. RESISTANCE

Main winding 3.7 ohms, Feedback winding 23 ohms.

INDUCTANCE

Main winding 1.65 MH.

TURNS RATIO

Main winding to Feedback winding 2:5 to 1.

*AUDIO POWER REQUIRED

At 1000 cycles to record 7 cm/per sec. ($2\frac{5}{8}$ inches/sec.) peak recorded velocity (NARTB Standard Level) - 1.26 watts or ± 31 dbm.

STABILITY

Change in level less than 1 db from 60°F. to 110°F.

STYLUS

Standard short shank $\frac{5}{8}$ inches long.

DAMPING

Dow-Corning Silicone Fluid.

MOUNTING

Universal mounting for all lathes. Cover Plate tapped for mounting Fairchild Hot Thermo-Stylus.

*Frequency response measured with PFB-150WA Amplifier, balanced FM Modulator, and Buckman-Meyer Light Pattern.

FM Modulator, and Buchmann-Meyer Light Pattern.

GRAMPIAN-GOTHAM

SPECIFICATIONS: GOTHAM PFB-150WA Power Amplifier

INPUT IMPEDANCE

150/600 ohms balanced or unbalanced.
5,000 ohms bridging - unbalanced.
2,500/10,000 ohms bridging - balanced.

INPUT LEVEL REQUIREMENT

16 dbm to +4 dbm for matching inputs (150/600).
0 dbm to +20 dbm for 2,500/5,000 ohm bridging.
+8 dbm to +28 dbm for 10,000 ohms bridging.
The above mentioned input levels are required at 1000 cycles to obtain 7 cm/sec. peak recorded velocity (NARTB Standard Level) on 33 1/2 and 45 rpm positions, and approximately 15 cm/sec. peak recorded velocity at 78 rpm.

GAIN (600 ohm input)

46 db at 1000 cycles (Flat, 33 1/2 & 45 rpm positions).
52 db at 1000 cycles (78 rpm position).

FREQUENCY RESPONSE (Complementing Cutterhead to achieve RIAA recording curve ± 2 db).

RIAA Recording Curve within 1 db from 30 16,000 cycles in 33 1/2, 45 and 78 positions, "FLAT" position above 1000 cycles within 1 db to 40,000 cycles.
(screwdriver adjustments counterclockwise).

DAMPING FACTOR

Better than 40.

RMS HARMONIC DISTORTION

Less than 0.7% from 40 - 15,000 cycles at 150 watts.
Less than 0.1% at 1000 cycles at 20 watts.

INTERMODULATION

Less than 1% at 150 watts output (4:1 ratio 50/7,000).

SIGNAL-TO-NOISE RATIO

62 db below 1 watt (7 cm/sec. recorded velocity)
84 db below 150 watts.

POWER CONSUMPTION

115 volts 50/60 cycles; single phase; (220 volts supplied on special order).
2.8 amps at zero output; 5.5 amps at 150 watts out.

METERING

750 ma. direct-indicating plate-current meter.

CONTROLS

3-position plate-metering switch; 4-position equalization control; 2 db/step gain control; power switch; two line fuses.

TERMINALS

Two 7-contact barrier strips; input and output.

TUBES

1 12AX7, 3 12BH7, 2 6BL7, 2 811-A, 2 3B2B (6BL4).

MOUNTING DIMENSIONS

Two 19" standard rack units; 10.5" high each; maximum depth 11".

WEIGHT

Amplifier unit 39 lbs; Power Supply 68 lbs. net.

FINISH

Light-grey Class "A" baked enamel; Cover Panels available in RCA umber-grey or black as desired. Control panels in natural brushed and anodized aluminum; engraved.

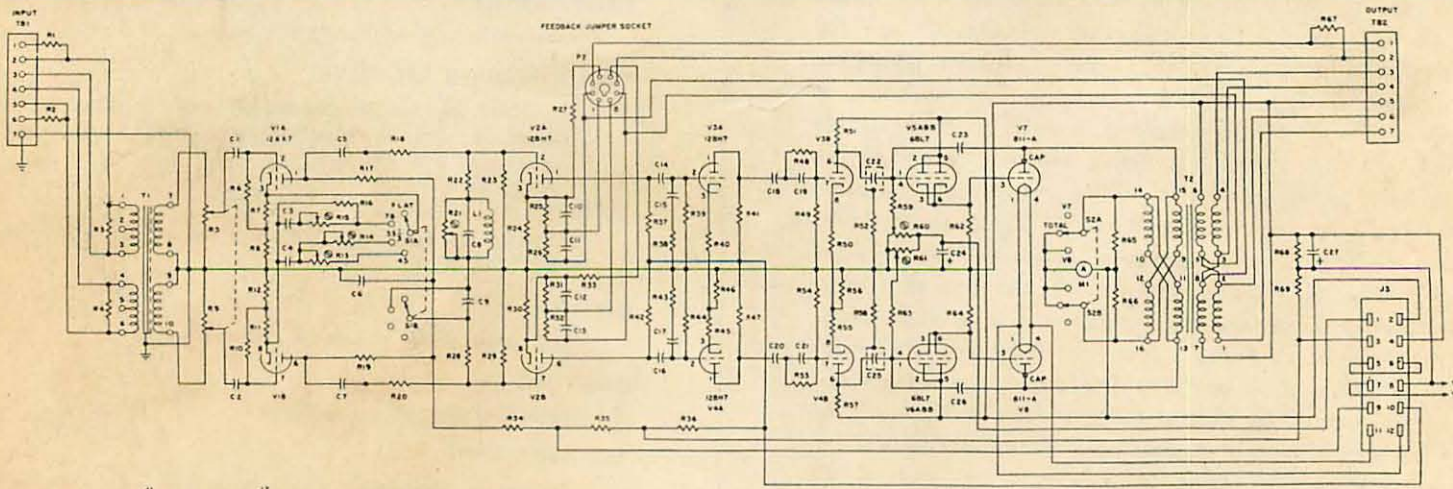
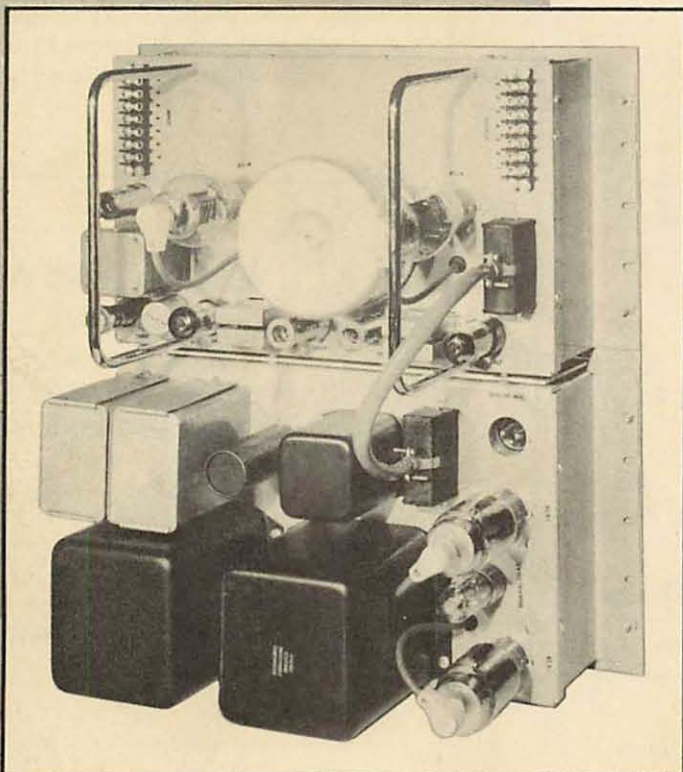
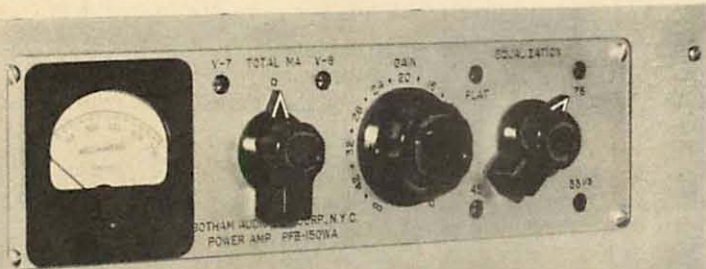

SCHEMATIC DIAGRAM, POWER AMPLIFIER PFB-150-WA

REEVES EQUIPMENT CORP.

10 East 52nd Street, New York 22, N. Y. • PLaza 9-7190

Cable address: Reevesquip