

American National Standard for television— digital control interface— electrical and mechanical characteristics

Approved January 27, 1984

Secretariat: Society of Motion Picture and Television Engineers

Page 1 of 12 pages

1. General

1.1 Scope. This standard defines the electrical and mechanical characteristics of an interface system comprised of a general purpose communication channel and interface device(s) used for the transfer of data and digital control signals between equipment utilized in the production, post-production, and/or transmission of visual and aural information. It is intended that the communication channel and device(s) described in this standard be part of an overall equipment interface, allowing interconnection of programmable and nonprogrammable control and accessory equipment as required to configure an operational system with a defined function. The standard is also intended to allow rapid reconfiguration of a system providing more than one defined function utilizing a given group of equipment.

1.1.1 The electrical and mechanical specifications set forth in this standard are intended for use in both fixed plant and field operational environments. These specifications take into account the requirement to function reliably without causing undue interference with other signals normally found in these environments.

1.1.2 This standard defines the electrical and mechanical characteristics of the communication channel and the associated interface device(s), to the exclusion of design specifications, performance requirements, safety requirements, and the communications protocol used in or by such equipment.

1.1.3 The primary intent of this standard is to establish an electrical and mechanical interface and communication channel for the purpose of interconnecting equipment by external means. This standard, or sections thereof, may be applied to the interconnection of elements within an item of equipment.

1.2 Definitions. For the purposes of this standard, the following definitions shall apply:

Equipment means either a single device which connects to the interface system or a group of interconnected devices, providing a specified operational function, having one common connection to the interface system.

Interface Bus refers to the communication channel.

1.3 Object. The intent of this standard is to:

Define a general-purpose interface system for use in the environment specified in 1.1

Specify equipment-independent electrical, mechanical, and functional interface characteristics which permit equipment to connect and communicate unambiguously via the interface system

Specify terminology and definitions related to the electrical and mechanical portion of the interface system

Enable the interconnection of independently manufactured equipment into a single functional system

Permit equipment with a wide range of operational capabilities to be connected to the interface system simultaneously

CAUTION NOTICE: This American National Standard may be revised or withdrawn at any time. The procedures of the American National Standards Institute require that action be taken to reaffirm, revise, or withdraw this standard no later than five years from the date of publication. Purchasers of American National Standards may receive current information on all standards by calling or writing the American National Standards Institute. Printed in USA

Define a system which is user configurable

Define a system based on readily obtainable standard components

1.4 Interface System Overview

1.4.1 This standard applies to systems, or portions of systems, which have the following characteristics:

A full-duplex four-wire communications channel is utilized

A nominal maximum bus length of 1220 m (4003 ft)

Data is transmitted asynchronously, bit serial, word serial

Standard transmission rate on the interface bus is 38.4 kilobits per second (kb/s)

Data exchange between devices is digital (as distinct from analog)

1.4.2 The function of the interface system is to provide an effective communications link over which messages are carried in an unambiguous way among a group of interconnected devices.

1.4.3 The interface system described in this standard assigns one of two operational characteristics to all devices:

Bus Controller. Each interface system contains one bus controller which supervises all tributaries in the system. This supervision is exercised through the use of interface protocol. The bus controller may also perform one or more functions in the operational plant in addition to its interface supervision. Although only one bus controller may be part of any particular interface system, it is recognized that an operational plant may make use of more than one interface system.

Tributary. A tributary transfers messages to and from an operational device via the interface system as specified in the interface system protocol. A tributary communicates messages through the interface bus only via the bus controller.

1.4.4 The basic message paths and the bus structure shall be as follows:

The basic message path utilizes asynchronous, bit serial/word serial transmission via a balanced wire pair

The interface bus may be utilized in either point-to-point or multi-point configuration including but not limited to

A point-to-point bus connecting one tributary to a bus controller

A multipoint bus connecting multiple tributaries to a single bus controller

The interface bus is a four-wire configuration which will effect two-way communication using a separate wire pair for each transmission direction; communication between tributaries is accomplished through the bus controller.

1.4.5 The data word and BREAK character utilized by the interface system shall be as follows:

The standard serial data word includes an eight-bit data byte; the complete serial data word consists of one start bit (SPACE), eight data bits (ONE BYTE), a parity bit (EVEN), and one stop bit (MARK). The least significant bit is transmitted first.

A BREAK character, comprised of 20 bits SPACE followed by a minimum of 2 bits MARK, is utilized to synchronize all devices connected to the interface bus.

2. Electrical Characteristics

2.1 Interface Circuit. The balanced voltage digital interface circuit is shown in Fig. 1. The circuit consists of three parts: the generator, the balanced interconnecting cable, and the load. The load may consist of one or more receivers (R) and an optional cable termination resistance (R_t). The electrical characteristics of the generator and receiver are specified in terms of direct electrical measurements while the interconnecting cable is specified in terms of its electrical and physical characteristics.

2.2 Generator Characteristics. The electrical characteristics of the generator are specified in accordance with measurements described in 2.2.1 through 2.2.6 and illustrated in Figs. 2 and 3. A generator circuit meeting these requirements results in a low impedance (100 ohms or less) balanced voltage source producing a differential voltage applied to the interconnecting cable in the range of 2 to 6 volts. The signalling sense of the voltages appearing across the interconnecting cable are defined as follows:

The B terminal of the generator shall be positive with respect to the A terminal for a binary 1 (MARK) state.

The B terminal of the generator shall be negative with respect to the A terminal for a binary 0 (SPACE) state.

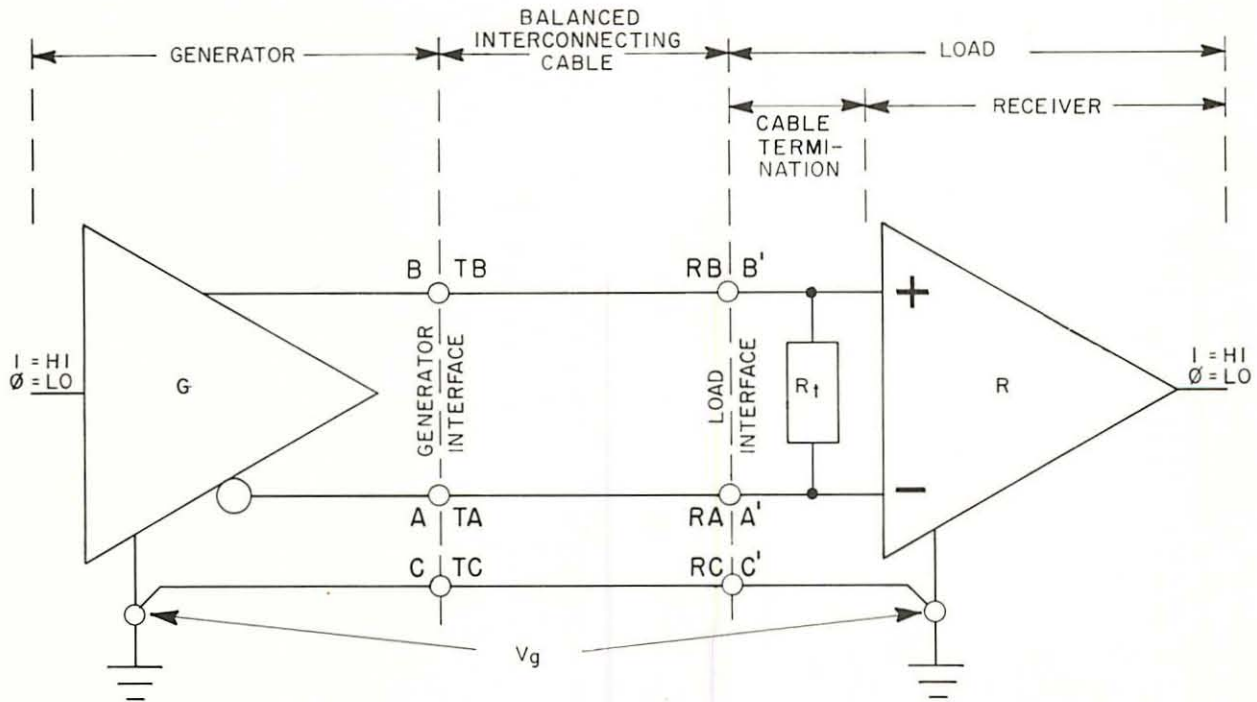

LEGEND

- R_t = CABLE TERMINATION RESISTANCE
- V_g = GROUND POTENTIAL DIFFERENCE
- A, B = GENERATOR INTERFACE POINTS
- A', B' = LOAD INTERFACE POINTS
- C = GENERATOR CIRCUIT GROUND
- C' = LOAD CIRCUIT GROUND

Fig. 1
Balanced Digital Interface Circuit

2.2.1 Open circuit measurement for either binary state shall be made in accordance with Fig. 2a. The results of this measurement shall be as follows:

The magnitude of the differential voltage (V_o) measured between the two generator output terminals shall not be more than 6.0 volts.

The magnitude of the voltage between either of the generator output terminals and generator ground (V_{oa} and V_{ob}) shall not be more than 6.0 volts.

2.2.2 The test termination measurement shall be made with a test load of two resistors, 50 ohm $\pm 1\%$, connected in series between the generator output terminals as shown in Fig. 2b. The results of this measurement shall be as follows:

The magnitude of the differential voltage (V_t) measured between the two output terminals shall not be less than either 2.0 volts or 50% of the magnitude of V_o , whichever is greater. For the opposite binary state the polarity of V_t shall be reversed (V_t).

The magnitude of the difference in magnitudes of V_i and \bar{V}_i shall be less than 0.4 volts.

The magnitude of the generator offset voltage, V_{os} , measured between the center point of the

test load and generator circuit shall not be greater than 3.0 volts.

The magnitude of the difference in the magnitudes of V_{os} for one binary state and V_{os} for the opposite binary state shall be less than 0.4 volts.

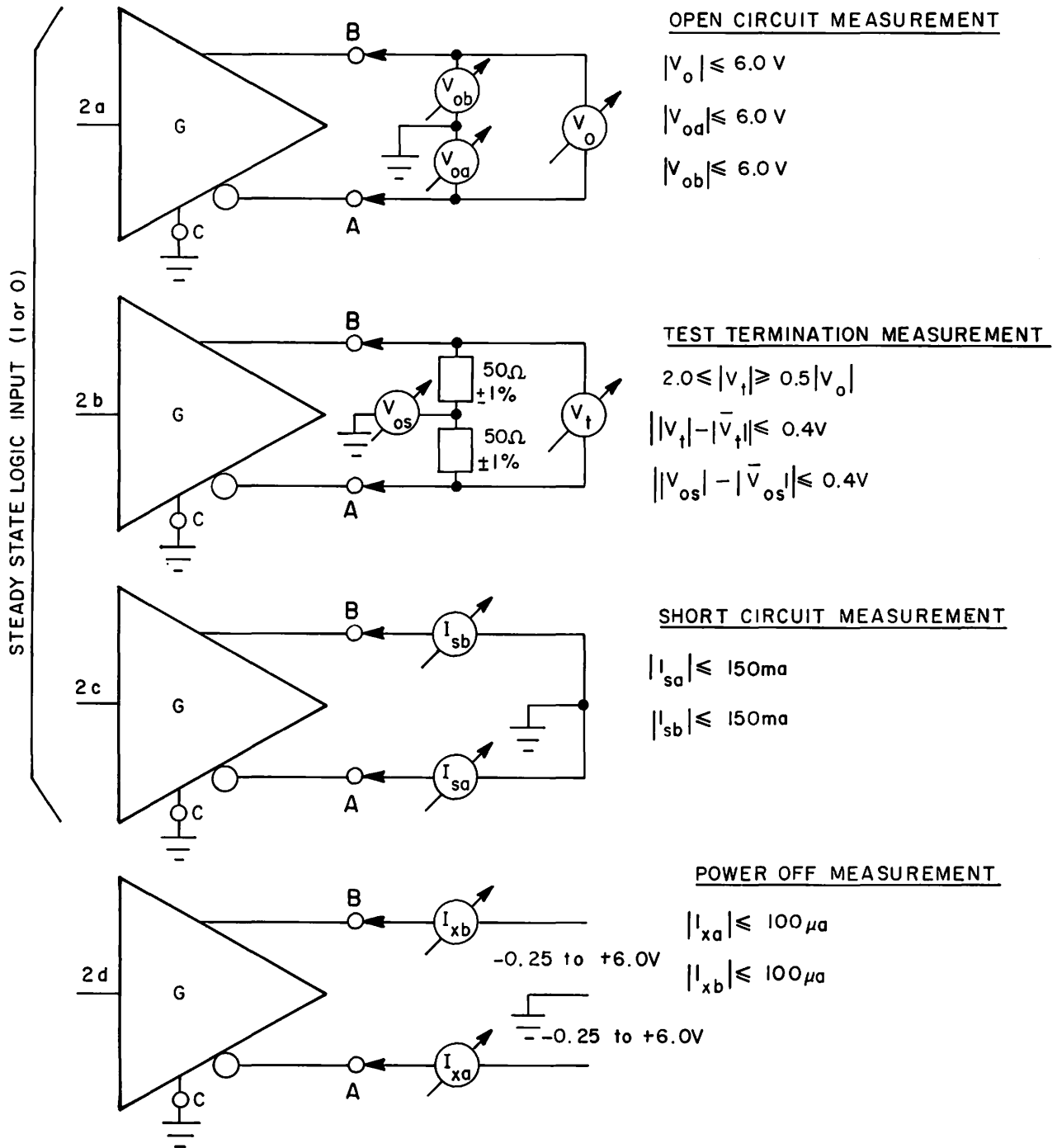

Fig. 2
Generator Parameter Measurement

2.2.3 The short circuit measurement shall be made with the generator output terminals short-circuited to generator circuit ground as illustrated in Fig. 2c. The magnitudes of the currents flowing through each generator output terminal during this test shall not exceed 150 milliamperes for either binary state.

2.2.4 The power-off measurement shall be made under power-off conditions and as illustrated in Fig. 2d. The magnitude of the generator output

leakage currents (I_{sa} and I_{sb}), with voltages ranging between +6.0 and -0.25 volts applied between each output terminal and generator circuit ground, shall not exceed 100 microamperes.

2.2.5 The output signal waveform measurement shall be made using a test load consisting of a noninductive resistor with a value of 100 ohms $\pm 10\%$ connected between the generator output terminals, as illustrated in Fig. 3. During transitions of the generator output between alternating

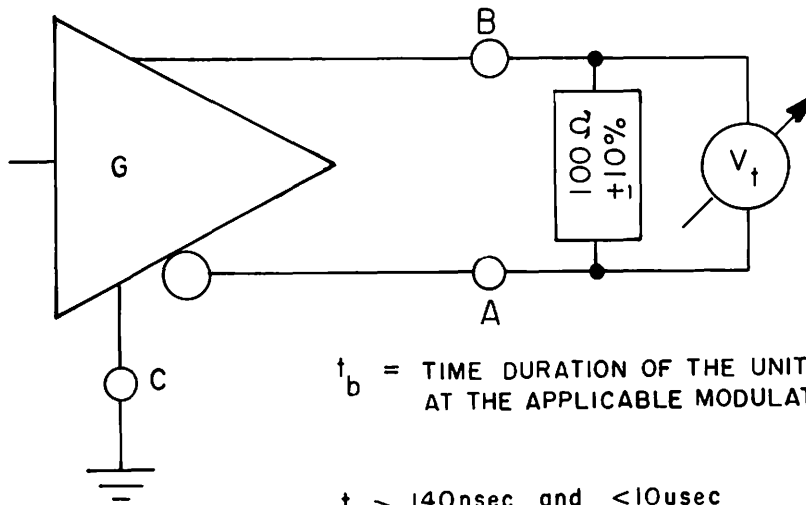

$V_{ss} =$ DIFFERENCE IN STEADY STATE VOLTAGES

$$V_{ss} = |V_t - \bar{V}_t|$$

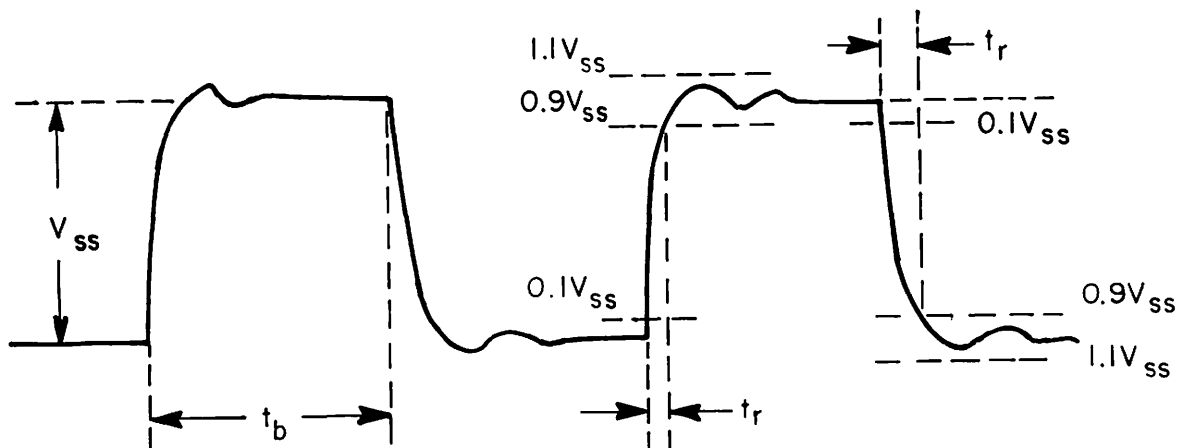

Fig. 3
Generator Output Signal Waveform

binary states (one-zero-one-zero, etc.), the differential signal measured across the test load shall be such that the voltage monotonically changes between 10% and 90% of V_{ss} at not less than 140 nanoseconds. Thereafter, the signal voltage shall not vary more than 10% of V_{ss} from the steady state value, until the next binary transition occurs. At no time shall the instantaneous magnitude of V_i or V_i exceed 6.0 volts nor be less than 2.0 volts. V_{ss} is defined as the voltage difference between the steady state values of the generator output.

2.2.6 The generator output shall be capable of being placed in a high-impedance state and when in such state shall withstand a common mode voltage swing of up to 7 volts.

2.3 Load Characteristics. The load consists of one or more receivers (R) and an optional cable termination resistance (R_t) as shown in Fig. 1. The electrical characteristics of a single receiver excluding both cable termination and fail-safe provision are specified in terms of the measurements described in 2.3.1 through 2.3.7 and illustrated in Figs. 4 through 6. A circuit meeting these requirements results in a differential receiver having a high-input impedance (> 4 kilohms), a small input threshold transition region between -0.5 and $+0.5$ volts and allowance for an internal bias voltage not to exceed 3 volts in magnitude.

2.3.1 The input current/voltage measurements shall be made with the voltage V_{ia} (or V_{ib}) ranging between -10.0 and $+10.0$ volts, while V_{ib} (or V_{ia}) is held at 0.0 volts (ground). This measurement shall be made with the power supply to the receiver in both the power-on and power-off condition. The resultant input current I_{ia} (or I_{ib}) shall remain within the shaded region shown in Fig. 4.

2.3.2 The input sensitivity measurement shall be made as illustrated in Fig. 5 over the entire common mode voltage (V_{cm}) range of -15 to $+15$ volts. The receiver shall not require a differential input voltage of more than 500 millivolts to correctly assume the intended binary state. Reversing the polarity of V_i shall cause the receiver to assume the opposite binary state. The receiver is required to maintain correct operation for differ-

ential input signal voltages ranging between 500 millivolts and 6 volts in magnitude. The maximum voltage (signal plus common mode) present between either receiver input terminal and receiver circuit ground shall not exceed 25 volts in magnitude. Application of voltages less than the maximum voltage (signal plus common mode) of 25 volts or a maximum differential signal of 15 volts at the receiver input terminals shall not result in operational failure of the receiver. The common mode voltage (V_{cm}) is defined as the algebraic mean of the two voltages appearing at the receiver input terminals (A' and B') with respect to the receiver circuit ground (C'). (Designers of terminating hardware should be aware that slow signal transitions with noise present may give rise to instability or oscillatory conditions in the receiving device and appropriate techniques should be implemented to prevent such behavior. For example, adequate hysteresis may be incorporated into the receiver to prevent this condition.)

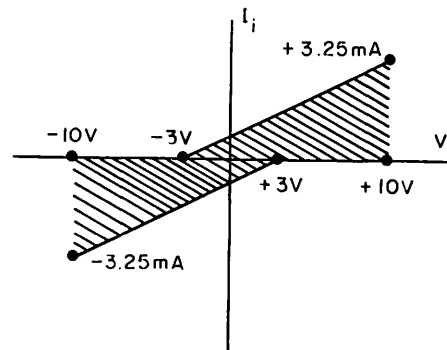
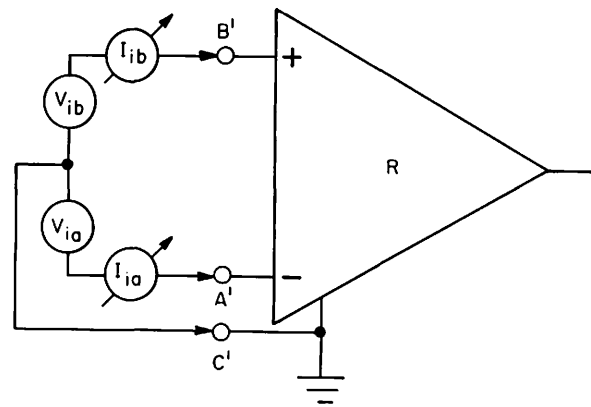
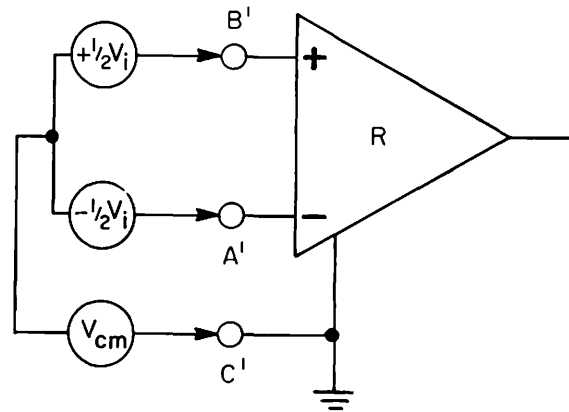

Fig. 4
Receiver Input Current-Voltage Measurement



$$V_{cm} = -15 \text{ to } +15 \text{ volts}$$

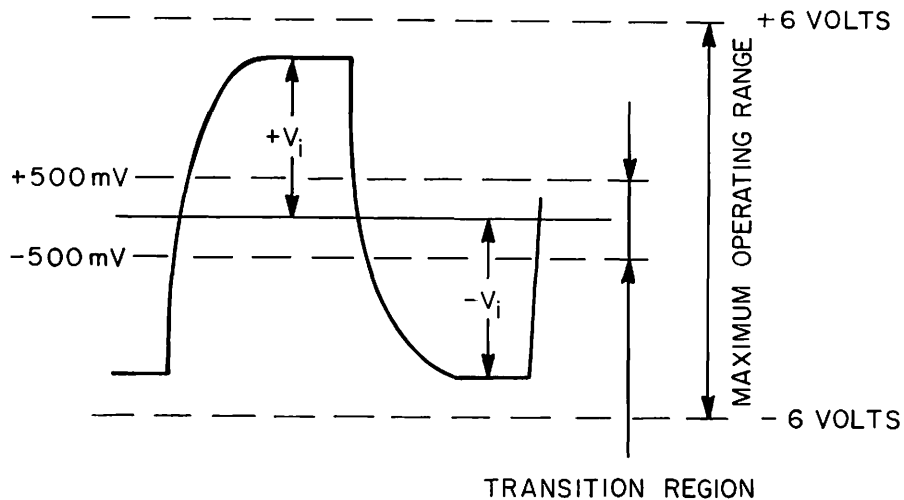

Fig. 5

Receiver Input Sensitivity Measurement

2.3.3 The Input balance measurement shall be made as illustrated in Fig. 6. The balance of the receiver input voltage/current characteristics and bias voltages shall be such that the receiver will remain in the intended binary state when a differential voltage (V_i) of 500 millivolts is applied through 500 ohms \pm 1% to each input terminal and V_{cm} is varied between -15 and $+15$ volts. When the polarity of V_i is reversed, the opposite binary state shall be maintained under the same conditions.

2.3.4 The use of a noninductive cable termination resistance (R_t) is recommended. A distributed resistive load or a combined R/C load may be re-

quired in some cases (see 4.2.1) and the use of an active cable termination resistance is desirable for the purpose of reducing cross coupling when the bus controller is placed in a high-impedance state (see 4.2.2). Care must be taken not to exceed the limits on total load resistance or sensitivity. Refer to 2.3.7 for limits on the total load resistance.

2.3.5 The use of multiple receivers may be employed. Caution must be exercised to avoid performance degradation due to signal reflective effects from stub lines emanating from the load interface point to the receivers.

2.3.6 The interface system shall fail safe. This shall be accomplished by automatic disconnection of a tributary from the interface system in the event of a malfunction or power failure and incorporating in the receiver provisions to provide a steady binary MARK to protect against the following conditions:

Generator power-off

Generator in high-impedance state

Both signal wires open or shorted (Signal common return still connected)

Generator not implemented (Signal leads may or may not be present)

Open connector (Both signal leads and the common signal return are open simultaneously)

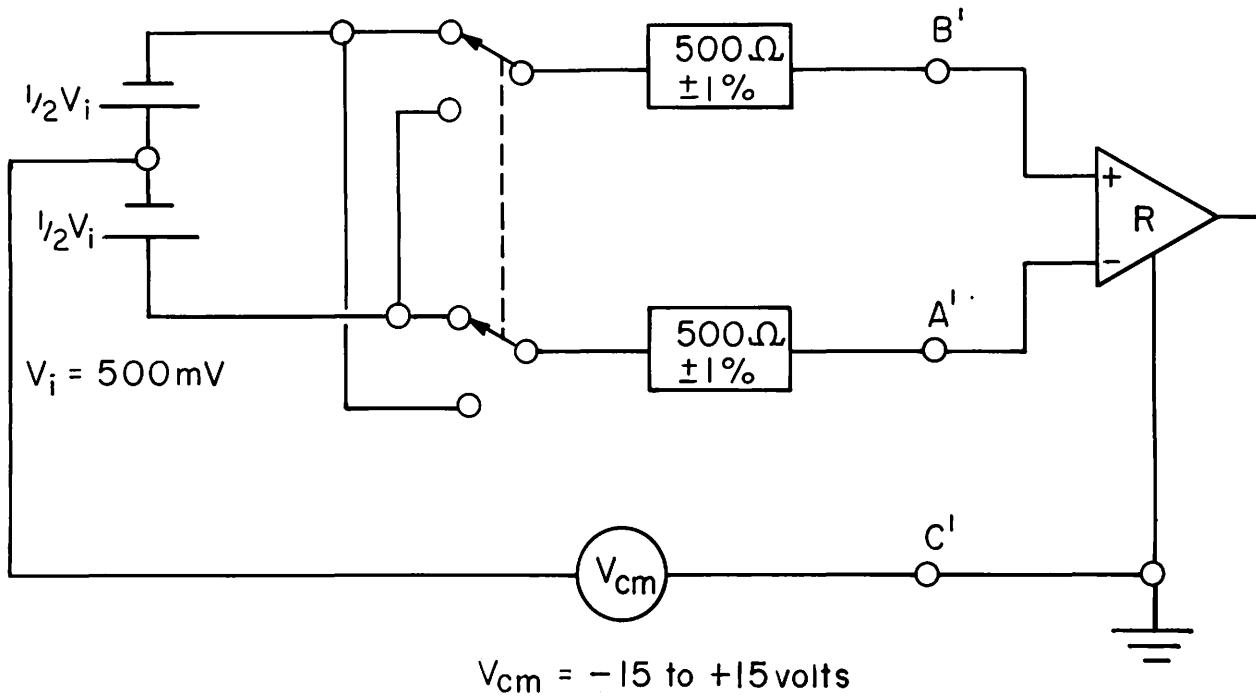

Fig. 6
Receiver Input Balance Measurement

2.3.7 The total load characteristics, including multiple receivers, fail-safe provision, and cable termination shall have a combined resistance greater than 90 ohms between its input points (A' and B' [Fig. 1]) and shall not require a differential input voltage of more than 500 millivolts for all receivers to assume the intended binary state.

2.4 Interconnecting Cable Characteristics. The physical and electrical characteristics of the interconnecting cable are given in 2.4.1 through 2.4.4 with additional guidance given in Sec. 4. An interconnecting cable conforming to this standard will result in a transmission line with a nominal characteristic impedance in the order of 100 ohms at frequencies greater than 100 kilo-

hertz, and a DC series loop resistance not exceeding 240 ohms over an operational loop length of nominally 1220 m. The cable may be composed of twisted or nontwisted (flat cable) conductors possessing the characteristics described in 2.4.1 through 2.4.4. Most commonly available cable used for telephone applications (nonloaded) will meet these specifications.

2.4.1 Each conductor of the interconnecting cable shall be composed of either a stranded or solid copper wire conductor with uniform overall diameter of at least 0.5 mm (0.02 in). Use of non-copper conductors is allowed providing they are of sufficient size to yield a DC wire resistance not exceeding 10 ohms per 100 m (30 ohms per 1000 ft) per conductor.

2.4.2 Mutual pair capacitance, that is, the capacitance between one wire in the pair and the other wire in the pair, shall not exceed 65 picofarads per meter (20 picofarads per ft) and the value shall be reasonably uniform over the entire length of the cable.

2.4.3 Stray capacitance, the capacitance between one wire in the cable and all others in the cable sheath with all others connected to ground, shall not exceed 130 picofarads per meter (40 picofarads per ft) and shall be reasonably uniform over the entire length of the cable for any given conductor.

2.4.4 Pair-to-pair balanced crosstalk is defined as the crosstalk between one pair of wires and any other pair of wires in the same cable. This crosstalk shall be attenuated a minimum of 40 dB when measured at 150 kHz with each cable pair terminated in its characteristic impedance tested in the circuit in which it is to be used.

2.5 Environment. A balanced-voltage digital interface circuit conforming to this standard will perform satisfactorily at a data rate of 38.4 kb/s providing that the following operational constraints are simultaneously observed.

The interconnecting cable length is a nominal maximum 1220 m and the cable is appropriately terminated.

The common mode voltage at the receiver is less than 15 volts (peak). Common mode voltage is defined as any uncompensated combination of the generator/receiver ground potential difference, the generator offset voltage (V_{os}), and the longitudinally coupled peak random noise voltage, measured between the receiver circuit ground and cable, with the generator end of the cable short-circuited to ground.

2.6 Circuit Protection. The balanced-voltage digital interface generator and receiver device, in either the power-on or power-off condition and complying with this standard, shall not be damaged under the following conditions:

Generator open circuit

Short-circuit across the balanced interconnecting cable

Short-circuit to any other lead using electrical characteristics in compliance with this standard

Short-circuit to ground

(The faults above may cause the power dissipation in the interface device to approach the maximum power dissipation tolerable by a typical integrated circuit (IC) package. Caution should, therefore, be exercised when multiple generators or receivers are implemented in a single IC package since only one such fault per package may be tolerated at any one time without experiencing IC failure. It should also be noted that the generator and receiver device(s) complying with this standard may be damaged by spurious voltages applied between the input/output terminals and circuit ground. In applications where the interconnect cable may be subject to severe electromagnetic environment or the possibility exists that it may be inadvertently connected to circuits not in compliance with this standard, additional protection should be employed as may be appropriate.)

3. Mechanical Characteristics

3.1 Interface Connector. The interface connector shall be a 9-pin D-subminiature female (DE-9S) with metric (M3) female screwlock. A single interface connector shall be associated with any particular tributary device. Multiple interface connectors may be utilized on a bus controller in the case of a multipoint system or when the bus controller must communicate with more than one interface system.

3.2 Pin Assignment. The pin assignments for the bus controller and tributary shall be as shown in Fig. 7. Use of the spare pin for unspecified communication or supervision is not in compliance with this standard. If used, it may not interfere with the normal operation of the standard interface system.

4. Guidelines

When interconnecting equipment using the interface system described in this standard, consideration should be given to some of the problems that may be encountered due to the characteristics of the interconnecting cable, cable termination, the number of devices in use, and grounding arrangements.

4.1 Cable. The interconnecting cable electrical characteristics are specified in 2.4. The following is intended to be used as additional guidance when considering the operational constraints placed on the system by the cable parameters.

4.1.1 The maximum length of cable separating the generator and receiver (load) is a function of modulation rate (influenced by the tolerable signal distortion), transmission losses, the amount of longitudinally coupled noise, and ground poten-

tial difference introduced between the generator and receiver circuit grounds as well as by cable balance. Increasing the physical separation and interconnecting cable length between the generator and receiver (load) interface points increases the system exposure to common mode noise, signal distortion, and the effects of cable imbalance. Users are advised to restrict cable length to the minimum consistent with the generator/receiver (load) separation requirements, and whenever possible to utilize cable specifically designed for balanced data circuits.

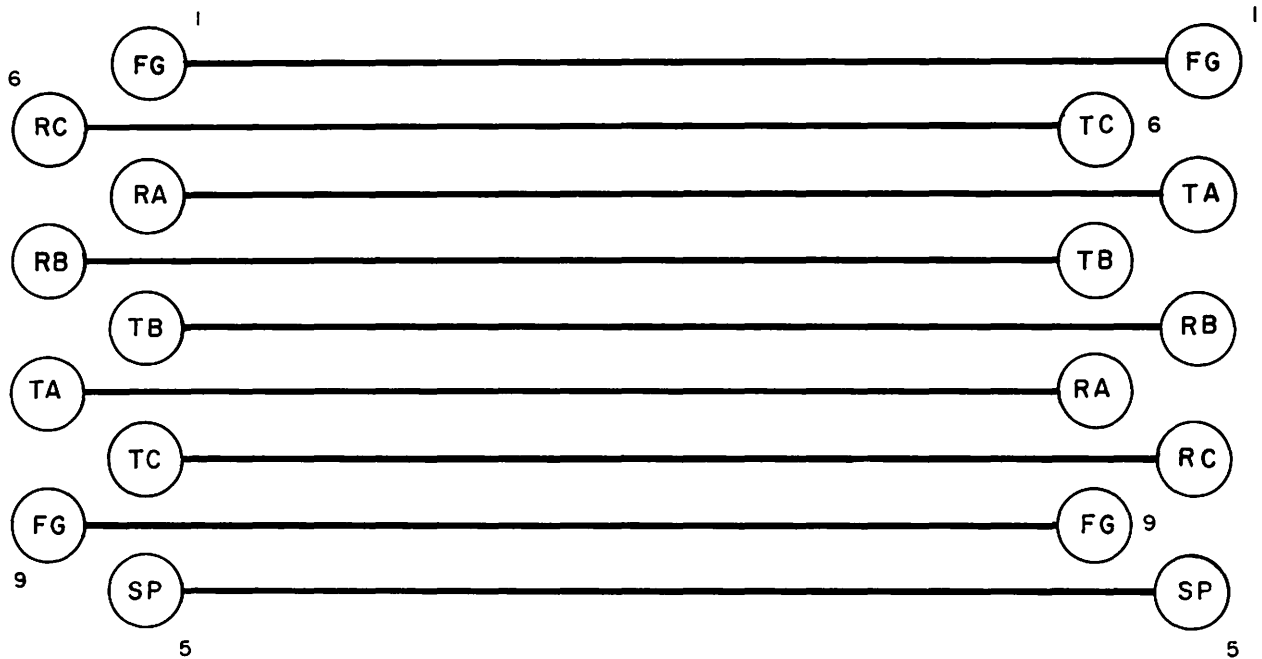

BUS CONTROLLER

TRIBUTARY

FG FRAME GROUND
 TA TRANSMIT "A"
 TB TRANSMIT "B"
 TC TRANSMIT SIGNAL COMMON
 RA RECEIVE "A"
 RB RECEIVE "B"
 RC RECEIVE SIGNAL COMMON
 SP SPARE

A < B "MARK" STATE
 A > B "SPACE" STATE

Fig. 7
Connector Pin Assignment

4.1.2 The nominal maximum cable length of 1220 m (4003 ft) is based upon:

Empirical data for nonloaded, twisted-pair telephone cable with copper conductors 0.5 mm (0.02 in) in diameter terminated in a 100-ohm resistive load

Signal rise and fall times equal to or less than 10 microseconds.

A maximum voltage loss between the generator and receiver (load) of 6 dB

(The user is cautioned that the nominal limit of 1220 m does not take into account cable imbalance or common mode noise beyond the limits set in this standard. Operation within the limit of 1220 m should result in a degradation of signal quality that will not exceed a zero-crossing ambiguity of 0.05 unit interval. It is recognized that many applications can tolerate a timing and amplitude distortion greater than this amount and in these cases correspondingly greater cable lengths may be employed. The use of cables specifically designed for the transmission of balanced data signals can also result in the ability to operate over substantially increased cable lengths.)

4.2 Cable Termination. The characteristics of the cable termination are specified in 2.3.4. The following is intended to be used as additional guidance when considering the operational constraints placed on the system by the termination resistance.

4.2.1 The determination of the type of cable termination utilized and its value must take into account the characteristic impedance of twisted-pair cable which is a function of operating frequency, wire size, wire type, and the kind of insulating materials used. The characteristic impedance of nonloaded, plastic-insulated, twisted-pair telephone cable with copper conductors 0.5 mm (0.02 in) in diameter is in the order of 100 ohms when measured with a 100 kHz sine wave.

The characteristic impedance of any cable typically contains an inductive component which could adversely affect the wave shape over extended cable lengths. Use of a composite R/C cable termination with a time constant of approximately 3 times the propagation delay of the cable may result in a significant improvement in the

wave shape and a reduction in driving power requirements.

4.2.2 The presence of stray capacitance between the interconnect cable and any adjacent cable (Fig. 8) can result in interference being coupled to an adjacent cable when a transition occurs that is other than balanced. During normal operation, inter-cable coupling is at a minimum due to the use of a balanced transmission mode along with control of signal rise-times (2.2). When the driving device is placed in a high-impedance state, however, this control is no longer applied and the conductor in the pair that was at a positive value will transition to a less positive value. This transition, being uncontrolled and of an unbalanced type, may be coupled into adjacent cables.

Capacitive coupling of this type can be reduced or eliminated by utilizing shielded cables specifically designed for the transmission of digital data information. Although this approach is practical when installing the interface system in new plants, it may not be possible when working in existing facilities. When utilizing nonshielded cable, the use of an active termination is recommended. An active termination of the type shown in Figs. 9 and 10 will result in a balanced transition to a voltage that is equal on both conductors of the cable pair. The circuit shown in Fig. 9 also provides a fail-safe bias on the bus and allows for higher impedance terminations while the circuit shown in Fig. 10 is balanced with respect to the interface bus and does not introduce a differential bias on the line.

4.2.3 In general, reliable operation of the balanced interface circuit is not particularly sensitive to the presence or absence of the cable termination resistor when operating at 38.4 kb/s. The termination of the cable with a noninductive load in the order of 90 to 250 ohms tends to result in the preservation of the rise time in the generated signal and a reduction of line noise. Caution must be exercised in the value of termination selected as too low a value would result in a reduction in signal amplitude to the point where reliable operation of the system would be affected.

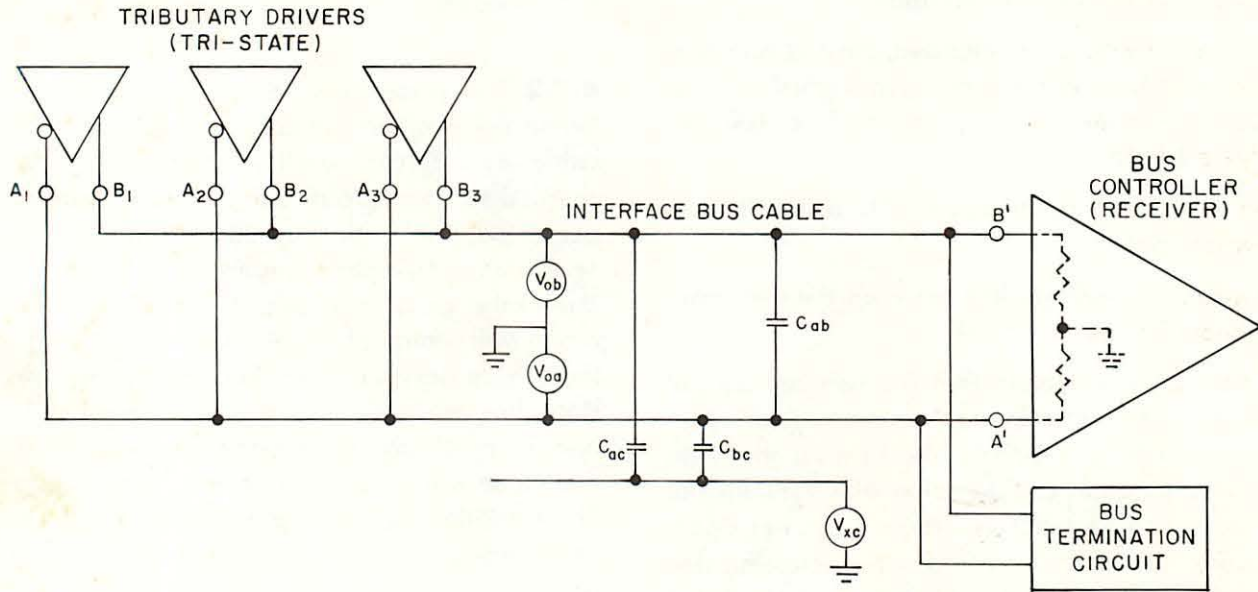
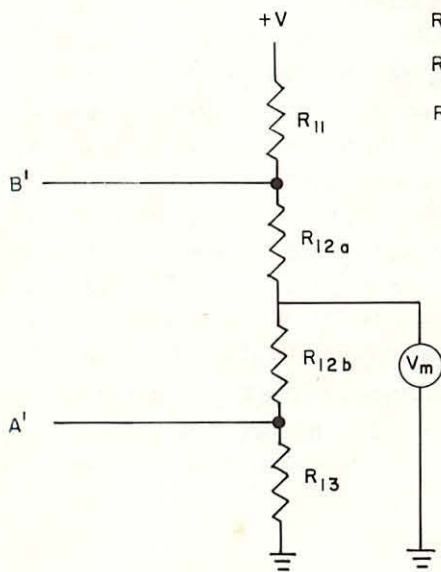

Fig. 8
Cable Model



$R_{12a} + R_{12b}$ ARE USUALLY COMBINED
 $R_{12} = R_{12a} + R_{12b}$ ALSO $R_{12a} = R_{12b}$
 $R_{11} \gg R_{12}$ $R_{13} \gg R_{12}$

Fig. 9
Terminator Circuit 1

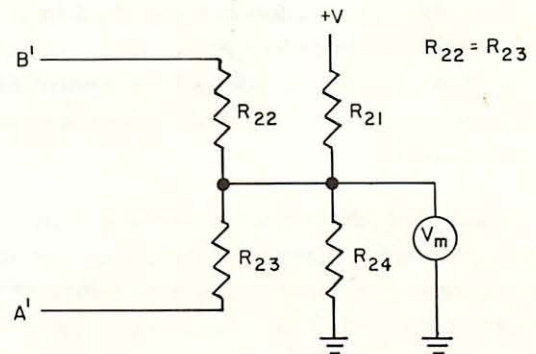

Fig. 10
Terminator Circuit 2

4.3 The data rate of 38.4 kb/s can result in a system response time within the equivalent of one television frame when the total number of tributaries is less than thirty-two. Higher data rates may be used when the operation of a specific system indicates this need. When higher data rates

are used, the device(s) shall first establish communication at 38.4 kb/s. Operation at data rates lower than 38.4 kb/s is expressly prohibited due to the possible confusion of certain data patterns with the BREAK sequence.