

PZM[®]-6D

PRESSURE ZONE MICROPHONE[®]

The PZM-6D is a Pressure Zone Microphone designed for professional recording, sound reinforcement, teleconferencing and broadcasting. Its low profile, unobtrusive appearance is appreciated in conference rooms, as well as on television, film and video productions. When suspended over an orchestra on a clear panel, the PZM practically disappears. Its miniature, permanently attached cable also reduces visual clutter.

The PZM-6D has a switchable dual frequency response: rising or flat. The "rising" position adds brilliance. This makes it useful wherever a crisp attack is desired, such as on percussion, drums or piano. The user can get a bright sound without boosting high frequencies on the recording console; the benefit is lower noise. The "flat" position provides a smooth, flat high-frequency response for natural sound reproduction.

Capable of withstanding up to 150 dB SPL without distortion, the PZM will never overload in practical use. Its electret condenser capsule provides a wide, smooth frequency response from 20 Hz to 20 kHz. Self noise is low, and sensitivity is high enough to override mixer noise in distant-miking applications.

Like other Pressure Zone Microphones, the 6D utilizes the Pressure Recording Process™ in which a miniature condenser microphone capsule is arranged very close to a sound-reflecting plate or boundary. The capsule is mounted in the "Pressure Zone" just above the boundary, a region where sound coming directly from the sound source combines in phase with sound reflected off the boundary. The benefits are a wide, smooth frequency response free of phase interference, excellent clarity and "reach," a hemispherical polar pattern and uncolored off-axis response.

Operating Instructions

The PZM-6D features self-contained electronics in the attached XLRM connector housing, which allows it to plug directly into a standard 12-48 VDC phantom power supply.

Crown makes an AC-powered model PH-4B supply for powering up to four PZMs. Also available is a single-channel AC/battery supply, Crown model PH-1A. For special applications, you can make your own battery supply as suggested in Fig. 3.

Using 2-conductor shielded microphone cable, plug the microphone into a phantom power supply. Connect the power supply output to a



Specifications

Type: Pressure Zone Microphone.

Transducer: Electret condenser.

Frequency response: 20 Hz to 20 kHz. See Fig. 1.

Polar pattern: Hemispherical when used on a floor, wall or ceiling.

Open circuit sensitivity: 7 mV/Pa* (-43 dB re 1 volt/Pa).

Power sensitivity: -43 dB re 1 mW/Pa. EIA sensitivity: -135 dBm.

Impedance: 240 ohms, balanced. Recommended minimum load impedance 1000 ohms.

Self-Noise: 20 dB equivalent sound pressure level, A-weighted.

S/N ratio: 74 dB at 94 dB SPL.

Maximum Sound Pressure Level: 150 dB SPL at the microphone produces 3% THD.

Polarity: Positive pressure on the diaphragm produces positive voltage on pin 2 with respect to pin 3 of the output connector.

Operating voltage: Phantom power, 12-48 volts DC, positive voltage on pins 2 and 3 with respect to pin 1 of the output connector.

Current drain: 1.1 mA.

Cable: Permanently attached 15-foot (4.58-m) black cable with an XLRM connector.

Switch: Frequency-response select switch for rising or flat response.

Color: Black.

Dimensions: 3-in. x 2.5-in. x .375-in. (7.62-cm x 6.35-cm x .95-cm). See Fig. 2.

Included accessories: PZM windscreen, carrying pouch.

Optional accessories: PH-4B phantom power supply (4 channels, AC powered). PH-1A phantom power supply (1 channel, battery or AC-adaptor powered).

* 1 pascal = 10 dynes/cm² = 10 microbars = 94 dB SPL.

Fig. 1

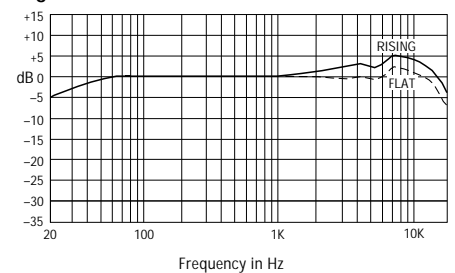

Legend ----- RISING
----- FLAT
Low frequency response depends on size of surface.

Fig. 2

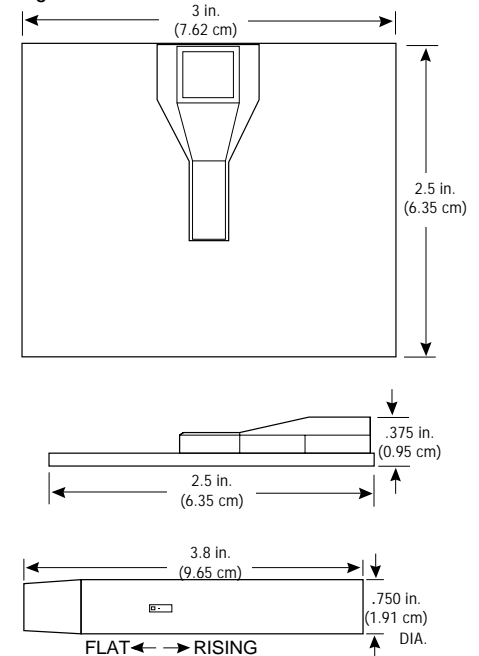

PZM[®]-6D

mixer input, or if your mixer has phantom power built in, simply plug the PZM direct into a mixer mic input.

Fig. 3

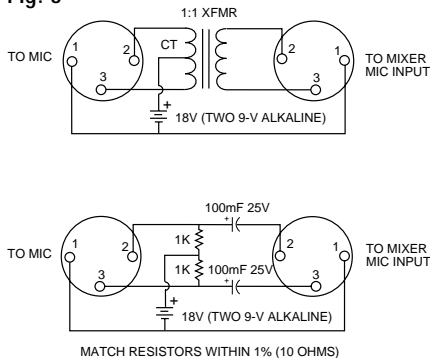

If your mixer or recorder requires an unbalanced phone plug connector, modify the cable exiting the power supply as follows: solder the cable shield and the pin-3 lead to the phone-plug ground terminal. Solder the pin-2 lead to the phone plug "hot" or "tip" terminal.

Placement

PZMs are designed to operate on any stiff, non-absorbent boundary (or surface). Typical boundaries are a floor, wall, ceiling or table. This type of mounting maintains the flattest low-frequency response.

The published response curve is measured on an "infinite" boundary such as a floor, ceiling or wall. The microphone's low-frequency response depends on the size of the boundary on which it

is placed. Specifically, the response begins to shelve down at and below the frequency F , where $F = 750/D$, and D = the boundary dimension in feet. At approximately $F = 188/D$, the output of the microphone is down 6 dB, becomes omnidirectional, and maintains a flat response down to approximately 30 Hz.

Several placement examples are described in the *Crown Boundary Mic Application Guide*, available free from your dealer or directly from the Crown Literature Department.

Architects' and Engineers' Specifications

The microphone shall be the Crown PZM-6D or equivalent. The microphone shall have a hemispherical pattern when used on an infinite boundary. The element shall be a sub-miniature electret type of rugged construction. A smooth frequency response from 20 Hz to 20 kHz shall be obtained. The response shall be switch-selectable between flat (F) or rising (R).

The microphone shall employ the patented PRP principle for maintaining phase coherency, thus eliminating comb filtering in the audible spectrum.

Permanently attached to the microphone is a fifteen-foot black cable with an XLRM connector.

The PZM-6D shall have a sensitivity of -43 dBV/Pa. The microphone shall accept 150 dB SPL input while contributing no greater than 3% THD (open circuit termination). Equivalent noise shall be typically 20 dBA re .0002 dyne/cm². The Crown PZM-6D is specified.

Warranty

Crown professional microphones are guaranteed unconditionally against malfunction from any cause for a period of three years from date of original purchase. Please refer to the enclosed full warranty sheet for more detail.

Service

If the microphone does not function properly, check that it is placed correctly and is connected as described in the Operating Instructions. Also check mic cables and your power supply. If the microphone is defective, return the microphone in its original packaging to: **Crown Service Department, Plant 2SW, 1718 W. Mishawaka Road, Elkhart, IN 46517.** For further assistance or technical support call **800-342-6939**.

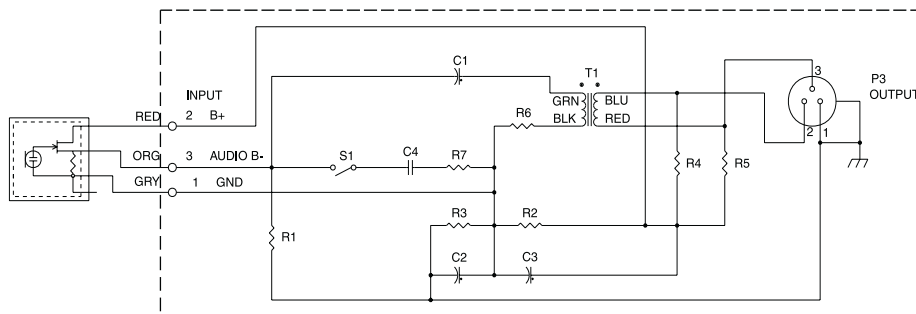

PZM-6D Schematic



Crown International, Inc.
P.O. Box 1000
Elkhart, IN 46515-1000
TEL: 219-294-8000
FAX: 219-294-8FAX

©2000 Crown International, Inc.
Crown[®], PZM[®] and Pressure Zone Microphone[®] are registered trademarks of Crown International, Inc. Pressure Recording Process is a trademark of E. M. Long Associates. Specifications subject to change without prior notice.