

- FAST SETTLING
- WIDEBAND PERFORMANCE
- NO EXTERNAL COMPENSATION
- GOOD DRIVE CAPABILITY

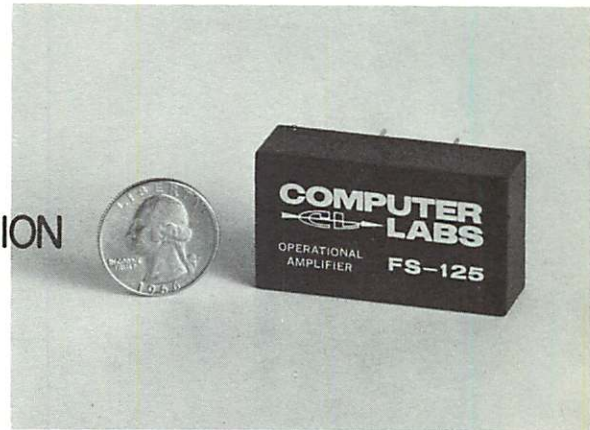

The Computer Labs FS-125 Operational Amplifier is specifically designed for fast output settling for step function signals. The design has been accomplished without sacrificing those characteristics which are important for accurate low drift operation.

Circuits using the FS-125 Operational Amplifier can be accurately calibrated with dc signals with assurance the circuits will be within 0.1% of their dc accuracy while operating at rates up to 12 MHz. This makes the FS-125 an excellent choice for sample-and-hold circuits, D/A converters, A/D converters, precision comparators, multiplexers, and a host of other "time domain" applications.

Either the FS-125 or the Model OA-125 Operational Amplifier will give wideband performance in any application requiring an inverting operational amplifier. In applications where settling time is important, the Model FS-125 is the ideal choice.

Applications which require a larger bandwidth and a larger gain bandwidth product than that available with the FS-125 should use the Model OA-125 Operational Amplifier. Applications of this type might include active filters, video amplifiers, and other "frequency domain" applications.

SPECIFICATIONS - Performance at 25°C with rated supply, unless otherwise indicated				
	Min.	Typ.	Max.	Units
INPUT: Single ended (inverting only)				
INPUT IMPEDANCE (Freq. = 20 Hz):	10	30		K ohms
†VOLTAGE GAIN (Open loop)	100,000*	500,000		
†INPUT OFFSET VOLTAGE		2.0	3.5	mV
vs. temperature		12*	5.0* 25*	mV uV/°C
†INPUT OFFSET CURRENT		1.5	2.5*	uA
vs. temperature		10*	30*	nA/°C
†SLEW RATE	250			V/us

†Test conditions shown on page 5

\*Specification from 0° to 70°C

	Min.	Typ.	Max.	Units
†INPUT NOISE				
Gain of 1			175	uVRMS
Gain of 2			100	uVRMS
Gain of 4			50	uVRMS
Gain of 8			20	uVRMS
Gain of 16			20	uVRMS
Gain of 1000			0.5	uVRMS
†SMALL SIGNAL BANDWIDTH (-3 dB; 50 mV P-P input)				
Gain of 1	30*			MHz
Gain of 2	30*			MHz
Gain of 4	26*			MHz
Gain of 8	10*			MHz
Gain of 16	4*			MHz
†LARGE SIGNAL BANDWIDTH (-3 dB; 4 V P-P output)				
Gain of 1	28*			MHz
Gain of 2	28*			MHz
Gain of 4	22*			MHz
Gain of 8	10*			MHz
Gain of 16	4*			MHz
†RISETIME (See Figure 1)				
Gain of 1			15*	ns
Gain of 2			15*	ns
Gain of 4			15*	ns
Gain of 8			30*	ns
Gain of 16			40*	ns
†ACQUISITION TIME (See Figure 1)				
Gain of 1			80	ns
Gain of 2			100	ns
Gain of 4			150	ns
Gain of 8			200	ns
Gain of 16			350	ns
Gain of 1			90*	ns
Gain of 2			110*	ns
Gain of 4			150*	ns
Gain of 8			220*	ns
Gain of 16			360*	ns
Definitions of Risetime and Acquisition Time are illustrated on idealized waveform in Figure 1				
†SMALL SIGNAL OPEN LOOP GAIN				
@ 1 MHz	750			
@ 2 MHz	400			
@ 5 MHz	100			
@ 10 MHz	35			
@ 20 MHz	10			
@ 50 MHz	6			
@ 100 MHz	2			

†Test conditions shown on pages 5 and 6

\*Specification from 0° to 70°C

(Continued on next page)

	Min.	Typ.	Max.	Units
†OUTPUT VOLTAGE 100-ohm load	+2.4* -2.2*			volts
200-ohm load	+3.0* -2.9*			volts
500-ohm load	+4.0* -3.5*			volts
†OUTPUT IMPEDANCE			1.0	ohm
†POWER SUPPLY SENSITIVITY				
$\frac{\Delta V \text{ summing node}}{\Delta V \text{ power supply}}$			200	$\mu\text{V/V}$

**POWER SUPPLY REQUIREMENTS**

The Model FS-125 will meet performance specifications with  $\pm 15$  volts  $\pm 3\%$  applied. Performance may be degraded if supply voltages are outside the 3% limits. Voltages greater than  $\pm 18$  volts should never be applied to the unit! If they are, catastrophic failures may occur. With 0 mA load current, +15 volt current is approximately +60 mA; -15 volt current is approximately -55 mA. With 20 mA load current, +15 volt current is approximately +80 mA; -15 volt current is approximately -60 mA.

Power supply voltage disturbances can affect the fast-settling characteristics of the FS-125. It is suggested that both power supplies be bypassed with a ceramic capacitor of 0.01 microfarad for high-frequency components and appropriate electrolytic capacitors for low-frequency components.

TEMPERATURE RANGE Operating Storage	0 -60		+70 +125	$^{\circ}\text{C}$ $^{\circ}\text{C}$
MECHANICAL Length Width Height Weight Volume		2.02 1.14 0.65 1.5	1.5	inches inches inches ounces cu. in.

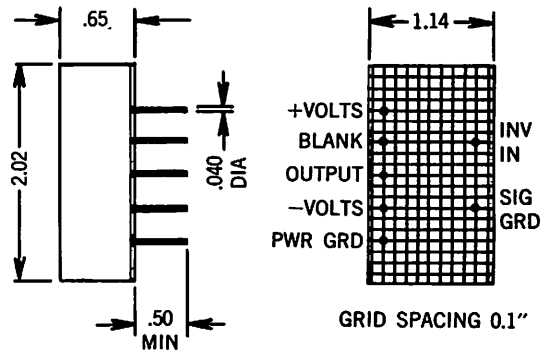

†Test conditions shown on page 6

\*Specification from 0 $^{\circ}$  to 70 $^{\circ}$  C

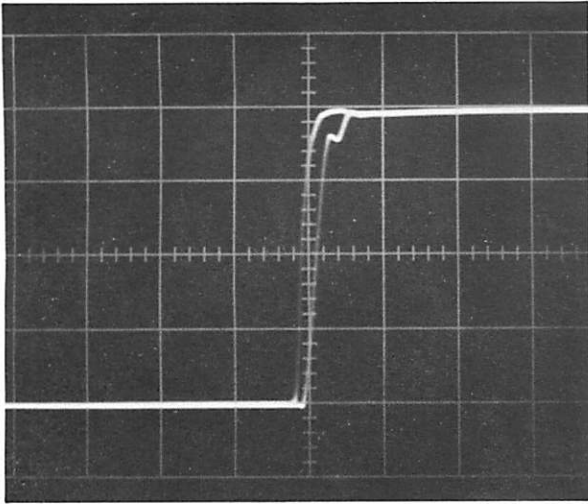

Photograph P-1

Input and (inverted) output superimposed to illustrate response of FS-125 to positive step function. Left trace is input. Oscilloscope used was Tektronix Type 454; settings 1 V/cm and 50 nsec/cm.  $R_{ff}$  and  $R_{fb}$  1000 ohms;  $R_L$  120 ohms.

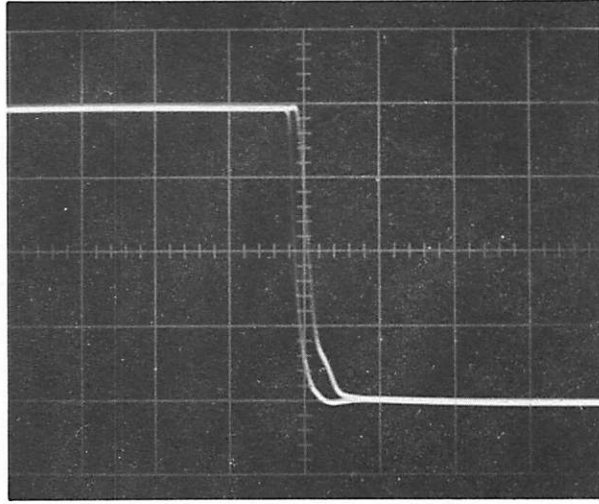

Photograph P-2

Input and (inverted) output superimposed to illustrate response of FS-125 to negative step function. Left trace is input. Oscilloscope used was Tektronix Type 454; settings 1 V/cm and 50 ns/cm.  $R_{ff}$  and  $R_{fb}$  1000 ohms;  $R_L$  120 ohms.

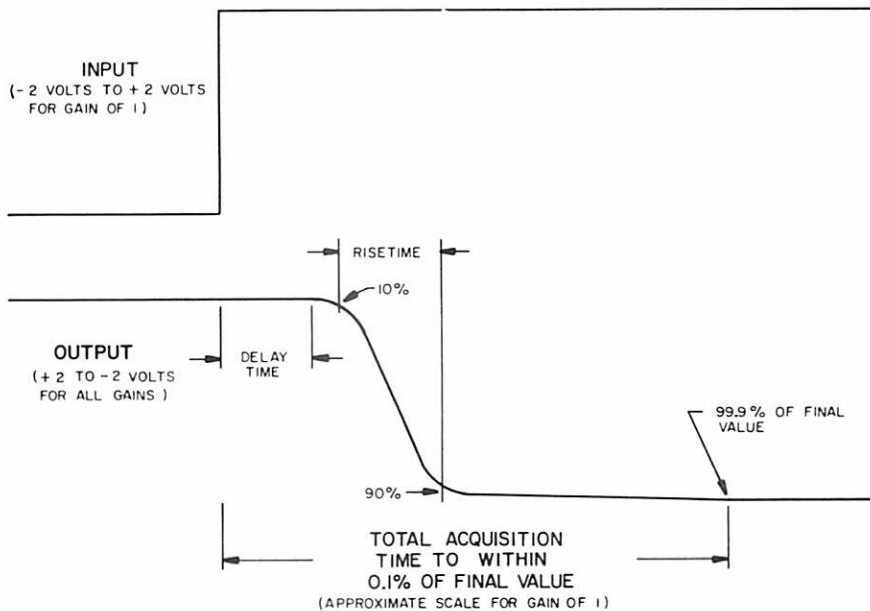
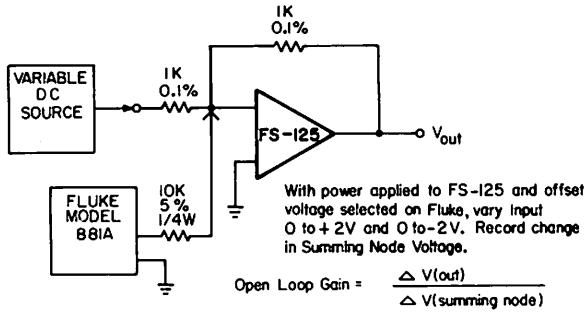
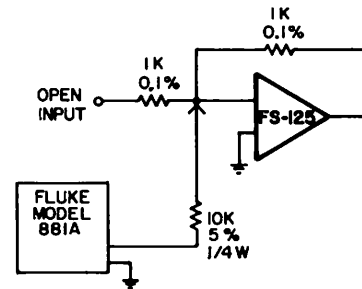

FIGURE I.



DC OPEN LOOP VOLTAGE GAIN TEST



INPUT OFFSET VOLTAGE TEST

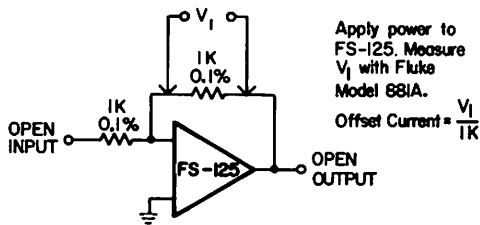

INPUT OFFSET CURRENT TEST

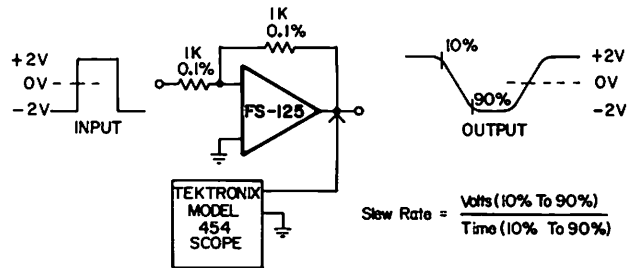

SLEW RATE TEST  
(Gain = 1)

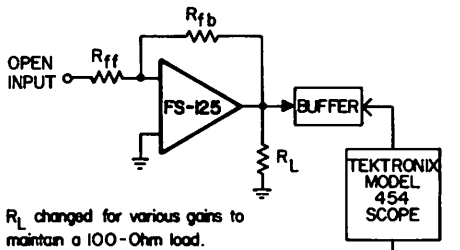

$R_L$  changed for various gains to maintain a 100-Ohm load.

GAIN	$R_{ff}$	$R_{fb}$	MAX. $\mu V$ RMS	Scope Reads Noise Peak To Peak.
1	1000	1000	175	Input RMS Noise = $0.25 \left( \frac{P-P \text{ Noise}}{\text{Gain}} \right)$
2	500	1000	100	
4	250	1000	50	
8	250	2000	20	
16	250	4000	20	
1000	250	250,000	0.5	

INPUT NOISE TESTS

Input is constant 50mV P-P for Small Signal Tests; varied as function of gain for Large Signal Tests.

Output varies as function of gain for Small Signal Tests; remains constant 4V P-P for Large Signal Tests.

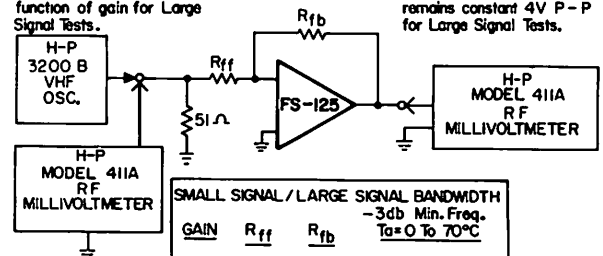

GAIN	$R_{ff}$	$R_{fb}$	SMALL SIGNAL / LARGE SIGNAL BANDWIDTH -3db Min. Freq. $T_a = 0 \text{ To } 70^\circ\text{C}$
1	1000	1000	30MHz / 28MHz
2	500	1000	30MHz / 28MHz
4	250	1000	26MHz / 22MHz
8	250	2000	10MHz / 10MHz
16	250	4000	4MHz / 4MHz

SMALL SIGNAL / LARGE SIGNAL BANDWIDTH TESTS

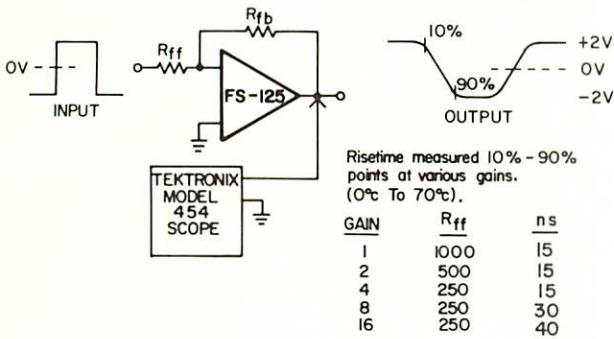

**RISETIME TESTS**  
(See Figure 1 For Definition)

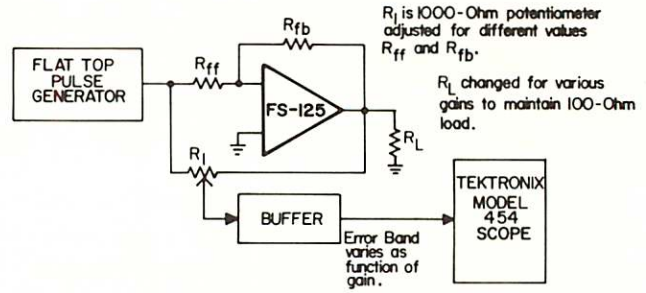

GAIN	R <sub>ff</sub>	R <sub>fb</sub>	Max. Acquisition Time To 0.1% Final Value		ERROR BAND
			T <sub>a</sub> = 25°C	T <sub>a</sub> = 0 To 70°C	
1	1000	1000	80 ns	90 ns	± 2 mV
2	500	1000	100 ns	110 ns	± 1-1/3 mV
4	250	1000	150 ns	150 ns	± 4/5 mV
8	250	2000	200 ns	220 ns	± 4/9 mV
16	250	4000	350 ns	360 ns	± 4/17 mV

**ACQUISITION TIME TESTS**  
(See Figure 1 For Definition)

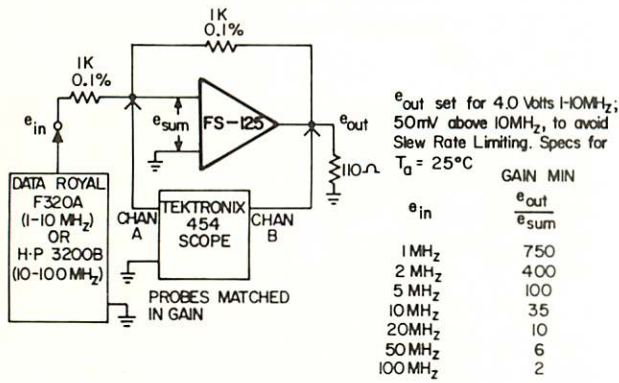

**SMALL SIGNAL OPEN LOOP GAIN TESTS**

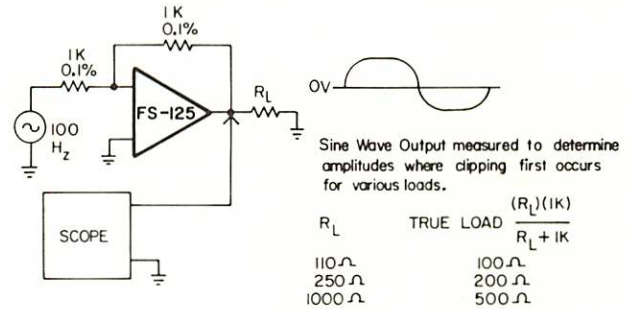

**OUTPUT VOLTAGE TESTS**

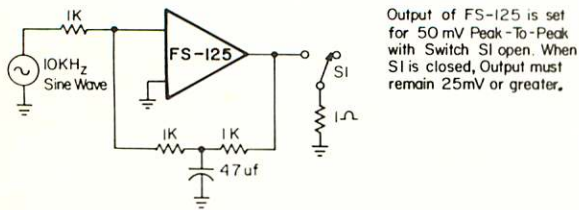

**OUTPUT IMPEDANCE TEST**

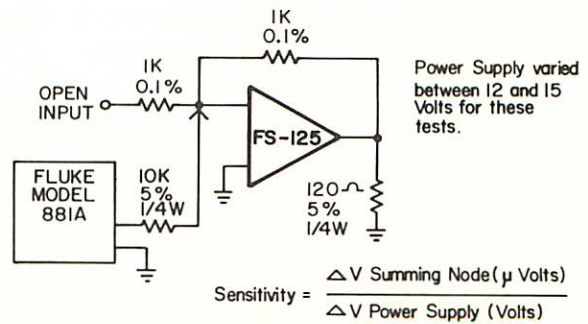

**POWER SUPPLY SENSITIVITY TESTS**

## NOTES ON DRIVING LUMPED CAPACITIVE LOADS

In some operational amplifier operations, it is necessary to drive lumped capacitive loads.

**NOTE:** Distributed capacitive loads such as coaxial cables, printed circuit wiring runs, and other transmission paths generally present no problem since they can be terminated in their characteristic impedance and made to appear resistive in nature. In this discussion, lumped capacitive loads such as the input capacitance of circuits that are being driven are the loads which are meant.

Lumped capacitive loads can cause instability in the operational amplifier and interfere with its fast settling characteristics, since capacitive loads cause additional phase lag which violates the stability criteria. The instability can manifest itself as either a few cycles of "ring" at the output after a sharp transition; or, in severe cases, as a continuous oscillation.

There are two possible methods for enhancing the ability of an operational amplifier to drive capacitive loads--resistive loading, and resistive isolation.

### RESISTIVE LOADING

A purely capacitive load can be made to appear less capacitive in nature by paralleling it with a resistance. This additional resistive load tends to cancel some of the effects of the capacitive load.

The minimum total load for the FS-125 Operational Amplifier should be 100 ohms. Therefore, the parallel combination of lumped capacitive load and the resistive loading should be more than 100 ohms at all frequencies up to the frequency of 3 dB response. This can be accomplished if the capacitive reactance and the resistive loading are each made 150 ohms at the frequency of 3 dB response. When they are, their parallel combination will be approximately 100 ohms and will meet the requirement for the minimum total load. Examples for several sets of feedback and feedforward resistors are shown in Table 1.

Table 1

$R_{ff}$	$R_{fb}$	Closed Loop Gain	Max. Capacitive Loading	3 db Freq. (Approx.)	Resistance Loading
1000	1000	X1	20 pf	50 MHz	150
500	1000	X2	25 pf	40 MHz	150
500	2000	X4	80 pf	12.5 MHz	150
500	4000	X8	160 pf	6.2 MHz	150
500	8000	X16	220 pf	3 MHz	150

Notice that the degree of allowable capacitive loading increases as the 3 dB frequency response decreases. This means that for a given closed loop gain, the maximum capacitive loading may be increased at the expense of decreasing the 3 dB frequency response. The simplest method of accomplishing this is by increasing the values of the feedback and feedforward resistors.

For unity closed loop gain using 1000 ohms as a feedback resistance and 1000 ohms as a feedforward resistance, the 3 dB bandwidth is approximately 50 MHz and the maximum capacitive loading is 20 picofarads (as shown in Table 1). Notice that the capacitive reactance of a 20 picofarad capacitor is approximately 150 ohms at 50 MHz. However, if the feedback resistance is increased to 8000 ohms and the feedforward resistance is increased to 8000 ohms, the 3 dB bandwidth decreases to approximately 2.5 MHz and the maximum allowable capacitive loading increases to 400 picofarads. The increase in the values of the feedforward and feedback resistance decreases the 3 dB response of the amplifier because the main limiting factor in the bandwidth of the FS-125 Operational Amplifier is the stray capacitance  $C_0$  shown in Figure A. The effect of this stray capacitance,  $C_0$ , is to cause a frequency roll-off dictated by the value of  $R_{fb}$ .

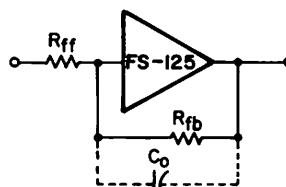

FIGURE A

Continued from reverse side

The fact that the value of the feedback resistor affects the 3 dB frequency response of the amplifier can be used to advantage in obtaining even faster settling times than those specified for the FS-125 Operational Amplifier. For example, the settling time specifications for a closed-loop gain of 16, using a 250 ohm feedforward resistance and a 4000 ohm feedback resistance, is 350 ns. However, if the feedforward resistance is decreased to 100 ohms and the feedback resistance is made 1600 ohms (still maintaining the closed loop gain at 16), the settling time to 0.1% of final value is reduced to 100 ns! **This reduction in the size of the feedback and feedforward resistances will have no effect on the stability of the FS-125 Operational Amplifier as long as the value of the feedback resistance is 1000 ohms or greater.**

#### RESISTIVE ISOLATION

The second method for driving lumped capacitive loads can be accomplished only in cases where the resistive component of the load is either precisely known or can be made to be precisely known. (i.e., by paralleling the load with a precision resistance, such as  $R_b$  in Figure B). In this method, the capacitive load is isolated from the operational amplifier by insertion of another precision resistance ( $R_a$ ) between the operational amplifier output and the lumped capacitive load, as shown in Figure B.

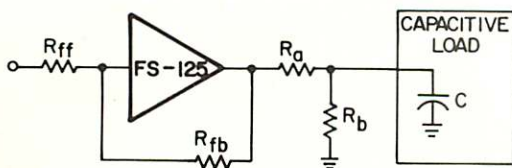

FIGURE B

The effect of resistance  $R_a$  is to isolate the lumped capacitive load from the output of the operational amplifier.

Since the resistive component of the lumped capacitive load is precisely known, the attenuation caused by the isolation resistance at low and mid-frequencies is precisely known. This loss may be compensated by increasing the closed loop gain of the operational amplifier by an appropriate amount. Resistance isolation, of course, reduces the effective bandwidth of the signal across the load. This bandwidth will be:

$$w = \frac{1}{R1C}$$

where

$R1$  is the parallel combination of  $R_a$  and  $R_b$ ; and  $C$  is the capacitance of the lumped capacitive load.

This reduction in bandwidth, however, may in some cases be less than that which would be obtained by increasing the feedforward and feedback resistances of the resistive loading method.