

type 6203

Wow and Flutter Meter

FEATURES:

- Fully automatic with manual override. No tuning required
- Meets DIN 45 507, IEC 386, CCIR 409 and IEEE 193
- Measurement of flutter and drift down to 0,001 and 0,01% peak respectively
- 3 Digit LED indication of % flutter range and % drift
- Out of range indication
- 0,3; 3 and 30 s averaging for drift measurements
- Weighted and linear modes with provision for connection of external filter
- 3,15 kHz, quartz crystal, test source built-in
- AC and DC outputs for level and XY recording

USES:

- Laboratory, studio and production line measurement of flutter and drift with sound as well as video recording and reproducing equipment
- Frequency analysis of flutter when used with external filter or analyzer
- Fault detection and diagnosis for service and maintenance work
- Early warning of equipment breakdown

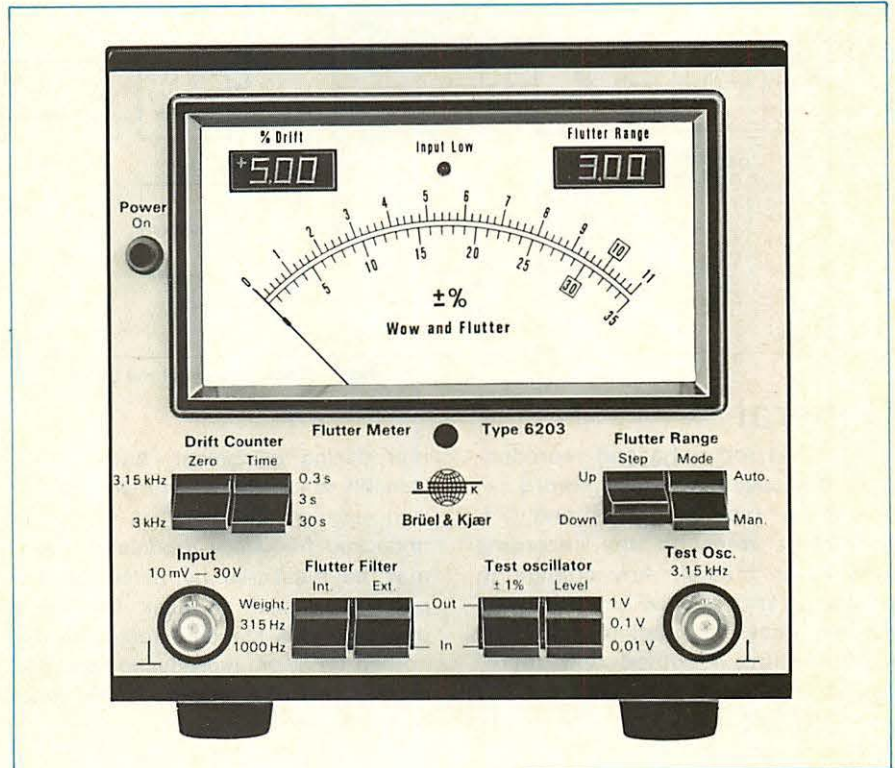

The Wow and Flutter Meter Type 6203 is a small, easy to use instrument using analogue and digital techniques for measurement of peak flutter and drift of sound recording and reproduction equipment. Automatic selection of five meter ranges from 0,035 to 3,5% for FSD with manual override and 3 digit LED indication of selected range, permit fast, accurate measurements suited to laboratory and studio work as well as production line testing of equipment and service.

Not only is the 6203 extremely easy to use, but it is fast and accurate. Simply connect its input with a 3 or 3,15 kHz test signal recorded on disc, film or tape and it will automatically select the correct measurement range, giving a direct indica-

tion of the percentage peak flutter in less than a second. Also indicated is the percentage drift of the nominal record-reproduce speed.

From just one spot measurement it may be immediately ascertained whether the recording and reproducing equipment under test is of acceptable quality and conforms to published specifications. Further, if several spot measurements are made then the influence of stylus tracking force and friction with the record groove as well as tape head pressure, tape tension variations and reel loading may be studied. Also spot measurements taken at regular intervals of say 1 month will indicate any unprecedented increase in flutter, thus warning of possible failure of equipment before breakdown occurs.

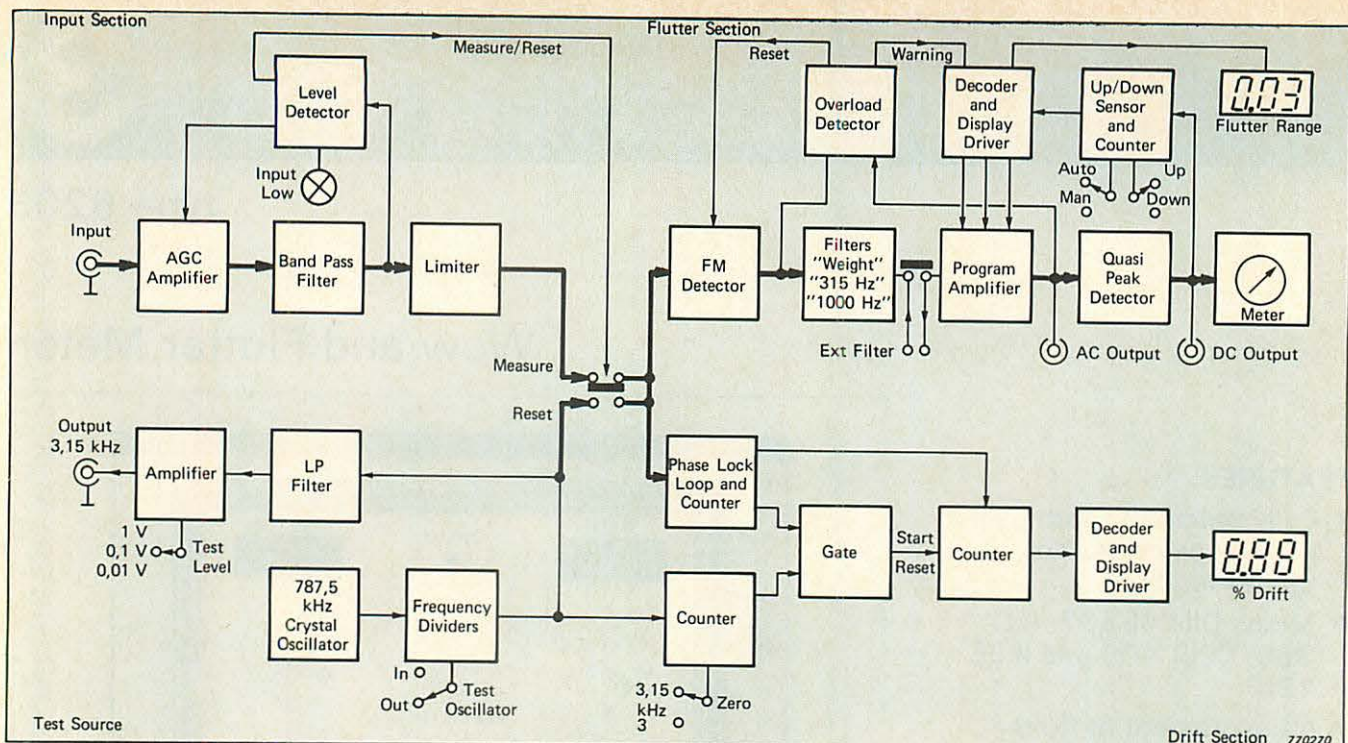

Fig.1. Block diagram of the 6203

General

In sound recording and reproduction, the speed at which record reproducers, tape recorders and film equipment transport the recording medium is critical. Any change in speed, no matter how small, results in frequency modulation that seriously distorts recorded and reproduced sounds, destroying clarity and listening pleasure. The main types of distortion are:

"Drift". Frequency modulation in the range below approximately 0,5 Hz that may be perceived as a steady or slow change in pitch.

"Wow". Frequency modulation in the range of approximately 0,5 to 10 Hz that may be perceived as a fluctuation in pitch of a tone.

"Flutter". Frequency modulation in the range of approximately 10 to 100 Hz that may be perceived as a roughening of the sound quality.

"Scrape Flutter". Frequency modulation in the range above approximately 100 Hz that may be perceived as a noise added to a reproduced sound that is not present when the sound is absent.

Measurement of the above types of distortion is not only useful in assessing the quality of sound recording and

reproducing equipment, but is also valuable in judging when maintenance is necessary. Since all are forms of undesired frequency modulation they may be measured by detecting the percentage peak to peak frequency deviation of a standard test tone recorded and/or reproduced on the equipment to be tested. Usually they are measured collectively in order to obtain a simple, easily interpreted indication of their audibility. Drift, wow, flutter and scrape are therefore often referred to collectively as "flutter". Here the word flutter means all forms of undesired frequency modulation in the 0,1 to 1000 Hz frequency range.

Description

The Flutter Meter Type 6203 has four basic sections. These are indicated in the block diagram of the instrument shown in Fig.1.

Input Section

The 6203 has two alternative INPUT sockets — a BNC coaxial socket on the front panel and a 5 pin DIN socket on the rear of the instrument. These are for application of a 3 or 3,15 kHz test signal from the sound recording and reproducing equipment to be tested.

From the INPUT sockets the test signal is applied to an amplifier and band pass filter, which amplify and clean the signal, removing extraneous noise and flutter components outside the measuring range of interest. Feedback from the band pass filter automatically adjusts the gain of the input amplifier so that test signal levels between 10 mV and 30 V may be accommodated without having to switch ranges. A level detector in the feedback loop automatically lights a red warning LED on the meter scale if the test signal level drops below 10 mV. At the same time it connects the Flutter and Drift sections of the instrument with the built-in test oscillator. This automatically resets the meter and LED displays back to zero, thus preventing false readings due to noise.

Flutter Section

For a meter indication the test signal is applied to the Flutter Section, which has a self tuning FM discriminator at its input. This adjusts automatically to the centre frequency of the test signal and demodulates the frequency deviations representing the flutter of the equipment under test. On overload, the discriminator time constant is automatically switched to a lower value to ensure rapid recovery.

Following the FM discriminator is an active filter. This has 0,1 to 315 Hz and 0,1 to 1000 Hz linear modes as well as a weighting mode which have the frequency characteristics shown in Fig.2 and may be selected using a front panel switch.

The weighting mode is used to obtain an objective indication of the audibility of the measured flutter and complies with DIN 45507, IEC 386, CCIR 409 and IEEE 193. For frequency analysis, sockets are provided on the rear panel for connection of an external filter or frequency analyzer in series with the internal filter.

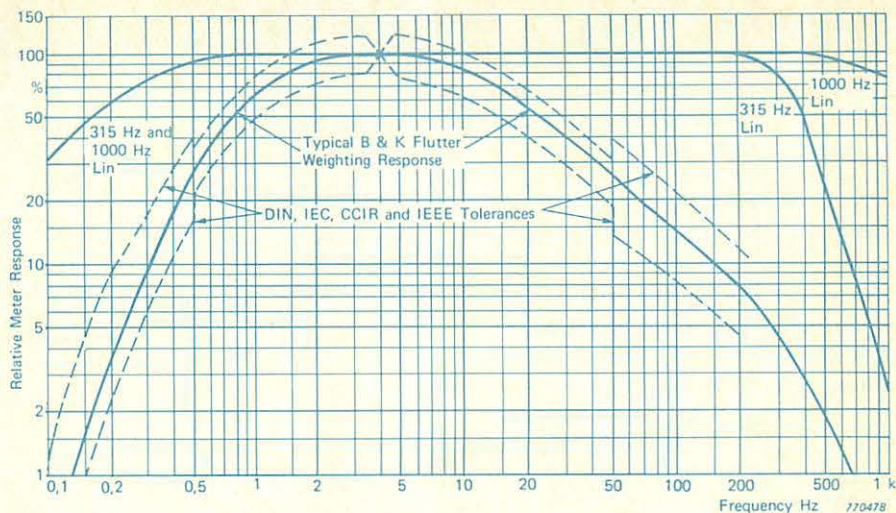

Fig.2. Filter characteristics of the 6203

After filtering, the demodulated signal is applied to a program amplifier and peak detector. These amplify and rectify the signal, providing low impedance outputs for recording, as well as a meter indication in accordance with the forementioned standards. The gain of the program amplifier is automatically switched to provide 0,03; 0,1; 0,3; 1 and 3% meter ranges. The correct range is selected by an up/down sensor which continuously monitors the level of the DC signal applied to the meter. False ranging is eliminated by using both time and amplitude hysteresis for ranging up and down. For manual selection, ranges may be stepped using a front panel switch. In addition the start range may be preselected using an internal switch.

For a digital indication of the particular flutter range selected, range information from the up/down sensor is decoded and applied to a 3 digit LED display in the top right-hand corner of the meter. On overload the display flashes on and off indicating that a higher range should be selected.

Test Oscillator

The 6203 has its own test signal source built-in. This is an ultra stable, quartz crystal oscillator operating at a frequency of 787,5 kHz which is stepped down to 3,15 kHz — the internationally agreed test frequency most used for flutter measurements.

For recording as a test signal, a low impedance output from the oscillator is available at a BNC coaxial

socket on the front panel of the 6203. Output levels of 0,01; 0,1 and 1 V may be selected, to suit most recording equipment. An alternative output, which produces a fixed test signal level of 10 mV is available via a 5 pin DIN socket on the rear panel.

Aside from serving as a test signal source for external recording equipment, the 3,15 kHz output of the oscillator is also used as a control reference with the internal measurement circuitry of the 6203. As a simple calibration check a test mode may be selected which frequency modulates the oscillator signal to produce a reference deflection of $\pm 1\%$ peak on the meter.

Drift Section

For measurement of fixed and very slowly changing differences in nominal record-reproduce speed, the frequency of the recorded test signal is compared with that of the internal test oscillator. This is done with the aid of two counters which may be switched for 0,3, 3 and 30 s counting times using a front panel switch. At the end of the selected counting time the counters operate a gate to produce a pulse with width proportional to the frequency difference. This is applied to a third counter which operates a 3 digit LED display in the top left hand corner of the meter giving a direct indication of the percentage drift. Both positive and negative values are indicated from 0,01 to 9,99%.

So as to prevent momentary drop-outs in the recorded test signal having a significant affect on the accuracy of the drift indication, the test signal counter has a phase locked loop at its input. This locks onto the recorded test signal producing a signal with the same frequency and phase relationship. However, when the test signal is momentarily absent, it fills in for it by free running at 3,15 kHz — the nominal test frequency.

In addition to selection of 0,3; 3 and 30 s counting times, the internal test oscillator counter may be switched so that percentage drift of 3 kHz as well as 3,15 kHz test signals may be measured. The 3 kHz mode also serves as a function check, as when the test signal is disconnected from the inputs of the instrument the drift indicator LEDs should always indicate + 5,00%.

Accessories Available

Test Record QR 2010

This is a 30 cm, high quality, stereo test record that is specially produced for detailed investigations on disc reproducing equipment. Both sides of the record have identical test programmes with test signals for frequency response, cross-talk and distortion measurements with record pick-ups. For measurement of flutter using the 6203 there is also a 1 minute recording of a 3,15 kHz test signal.

Examples of Use

Where more than just a spot measurement of flutter is required, flutter may be frequency analyzed. For this purpose the 6203 may be connected with an external filter such as the Tunable Band Pass Filter Type 1621 shown in Fig.3.

A typical flutter spectrogram obtained using the above analysis set-up is shown in Fig.4. This clearly indicates the precise frequencies of the major flutter components which, with a little knowledge of the record-reproduce equipment under test, can be related directly to the rotation of specific moving parts in the equipment. Such faults as poor vibration mounting and lubrication, worn or faulty bearings and minute eccentricities in machining and fitment of parts can be spotted which is of considerable help in servicing and where design improvements have to be made.

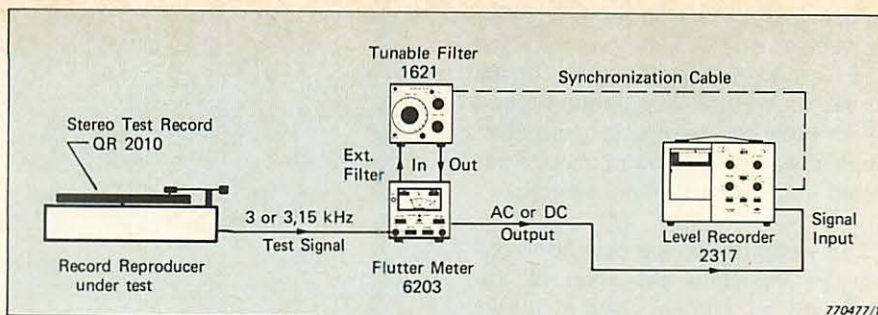

Fig.3. Instrument arrangement for third octave analysis of flutter

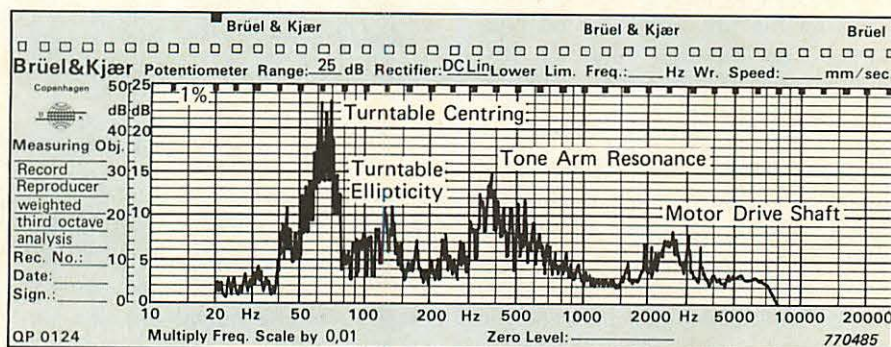

Fig.4. Typical third octave analysis of flutter produced by a record reproducer

Specifications 6203

Flutter Indication:

Moving coil meter giving quasi peak indication of % peak flutter in accordance with DIN 45507, IEC 386, CCIR 409-2 and IEEE 193

Ranges: 0,03; 0,1; 0,3; 1 and 3% peak

Accuracy: $\pm 2\%$ FSD

Range Selection: Automatic and Manual with 3 digit LED indication of selected range in top right hand corner of meter. Range preselector switch also provided

Overload: Flutter range LEDs flash for peak overloads ≥ 3 times range setting

Drift Counter:

3 digit LED display in top left hand corner of meter indicates % drift of test signal carrier

Range: $\pm 0,01$ to $\pm 9,99\%$ relative to 3 or 3,15 kHz

Accuracy: ± 20 ppm ± 1 LSD (Least Significant Digit)

Measuring Time: 0,3; 3 and 30 s — selectable

Out of Range: Drift display flashes for input frequencies $> 3,15$ kHz $+10\%$ or > 3 kHz -10%

Filter Modes

Weight: In accordance with the above standards

315 Hz: 0,1 to 315 Hz (-3 dB) linear

1000 Hz: 0,1 to 1000 Hz (-3 dB) linear

Ext: Provision for connection of external filter in series with anyone of the above internal filters

Test Signal Input

Via BNC socket on front panel and 5 pin DIN socket on rear panel

Voltage: 10 mV to 30 V

Frequency: 3 kHz -10% to 3,15 kHz $+10\%$

Impedance: > 47 K Ω

Test Signal Output:

From built-in quartz crystal reference source via BNC socket on front panel and 5 pin DIN socket on rear panel

Frequency: 3,15 kHz sine

Voltage: 0,01; 0,1 and 1 V RMS

Impedance: 600 Ω^*

AC Output:

From meter amplifier via BNC socket on rear panel

Voltage: 1 V pk corresponding to 10 and 30 on meter scale

Impedance: 1 K Ω^*

DC Output:

From meter detector via BNC socket on rear panel

Voltage: 1 V DC corresponding to 10 and 30 on meter scale

Impedance: 1 K Ω^*

Max. FM Noise:

Weighted: $\pm 0,0005\%$

0,1 to 315 Hz: $\pm 0,002\%$

0,1 to 1000 Hz: $\pm 0,01\%$

To Ext. Filter Power Input:

7 pin DIN socket on rear panel. Provides unfiltered 8 V (200 mA) DC for powering

an external filter such as the Tunable Band Pass Filter Type 1621

Power Requirements:

100; 115; 127; 200; 220; 240V AC $\pm 10\%$ (50 to 400 Hz), 8VA. Complies with safety class 1 of IEC 348

Temperature Range:

Operation: $+5$ to $+40^\circ\text{C}$ ($+41$ to $+104^\circ\text{F}$) all specifications valid

Storage: -25 to $+70^\circ\text{C}$ (-13 to $+158^\circ\text{F}$)

Max. Humidity:

90% RH (non condensing) at 30°C

Electromagnetic Compatibility:

Complies with Class B device of American FCC (Federal Communication Commission) Rules

Weight:

2,3 kg (5,1 lb)

Dimensions:

B & K module cabinet KK 0024, 4/12 of 19" rack module

Height: 132,6 mm (5,2 in)

Width: 139,5 mm (5,5 in)

Depth: 200 mm (7,9 in)

Accessories Included:

2 BNC coaxial cables AO 0133

1 Cable with 7 pin DIN plugs AQ 0042

4 40 mA slow blow mains fuses VF 0048

1 Mains Cable AN 0010

Accessories Available:

Stereo Test Record QR 2010

* Short circuit protected