

Sine/Noise Generators

types 1049 and 1051

USES:

- Wide-range, 1 mHz resolution, signal generators for electronic design, instrument test and repair
- Bus controlled, quality-control and production-line testing of electrical and mechanical products
- Swept-frequency measurement and synchronized recording of amplitude, phase and distortion response of audio recording and reproducing equipment, telephone systems, hearing aids, microphones, loudspeakers and hydrophones etc.
- Excitation source for building-acoustic measurements, vibration testing of mechanical structures and components, plus psychoacoustic, medical and biological research

FEATURES:

- 0,2 to 200 000 Hz, digitally controlled, sine generators with frequency resolution down to 1 mHz and clock stability better than $\pm 5 \cdot 10^{-6}$ /year
- Six-decade frequency sweep in one continuous range with selectable lower and upper limits
- Choice of linear and logarithmic frequency sweep with sweep rates from 0,001 Hz to 999,9 kHz/s and 0,001 mDec to 2 Dec/s respectively

The B & K Types 1049 and 1051 are two microprocessor-based sine generators which combine today's needs of increased spectral purity, frequency resolution and stability with ease of use and versatility. Their wide frequency coverage from 0,2 Hz to 200 kHz, with amplitude linearity and frequency resolution of $\pm 0,05$ dB and 1 mHz, make them suitable for numerous applications in electronic engineering, as well as in acoustics and vibration measurements. Linear and logarithmic sweep ranges, each with their own user-presettable lower and upper limits may be chosen, including extended linear sweeps from 0,001 Hz to 200 kHz. Single, repetitive and continuous sweep modes are also included and the time for each individual sweep is automatically calculated and displayed.

- Single, repetitive (1–99) and continuous sweep modes with 0,01 to 100,0 s pause between sweeps
- Calibrated output from 100 μ V to 5V with less than –96 dB harmonic and spurious distortion
- 1024 point amplitude memory, with automatic amplitude interpolation, for preconditioned test excitation
- 40 character, alphanumeric, line display for monitoring and setting-up of frequency and amplitude sweep parameters etc.
- 9 set-ups for recalling frequently repeated excitation test and measurement sequences
- Versatile IEEE/IEC bus for remote control and digital output of data
- Remote control functions for synchronous operation of Level and X-Y Recorders

ADDITIONAL FEATURES 1049:

- Narrow-band random, white and pink noise modes
- Logarithmic amplitude sweep with sweep rates from 0,1 to 999 dB/s
- 126 dB compressor circuit for active control of sound or vibration level at exciter output
- Automatic learn mode for amplitude memory, via compressor

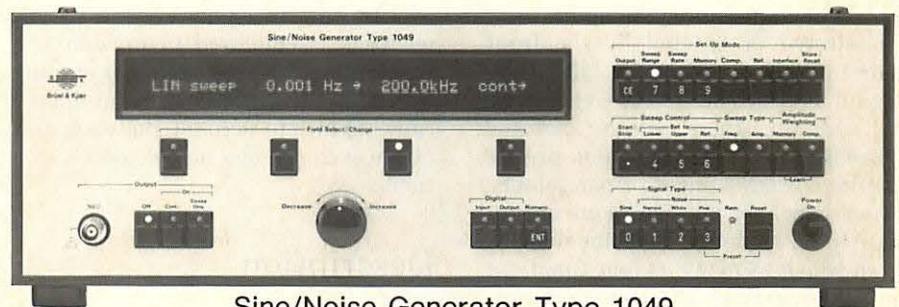

Sine/Noise Generator Type 1049

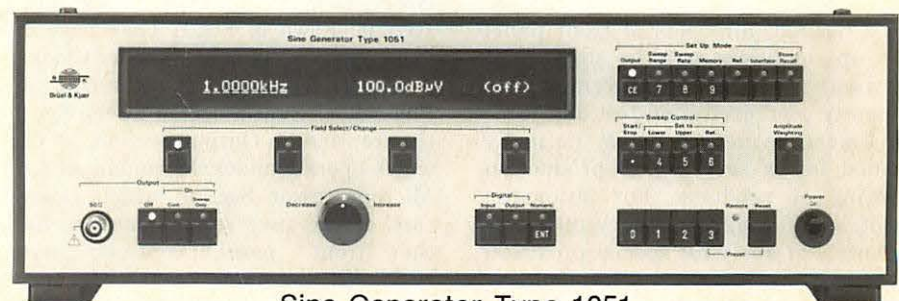

Sine Generator Type 1051

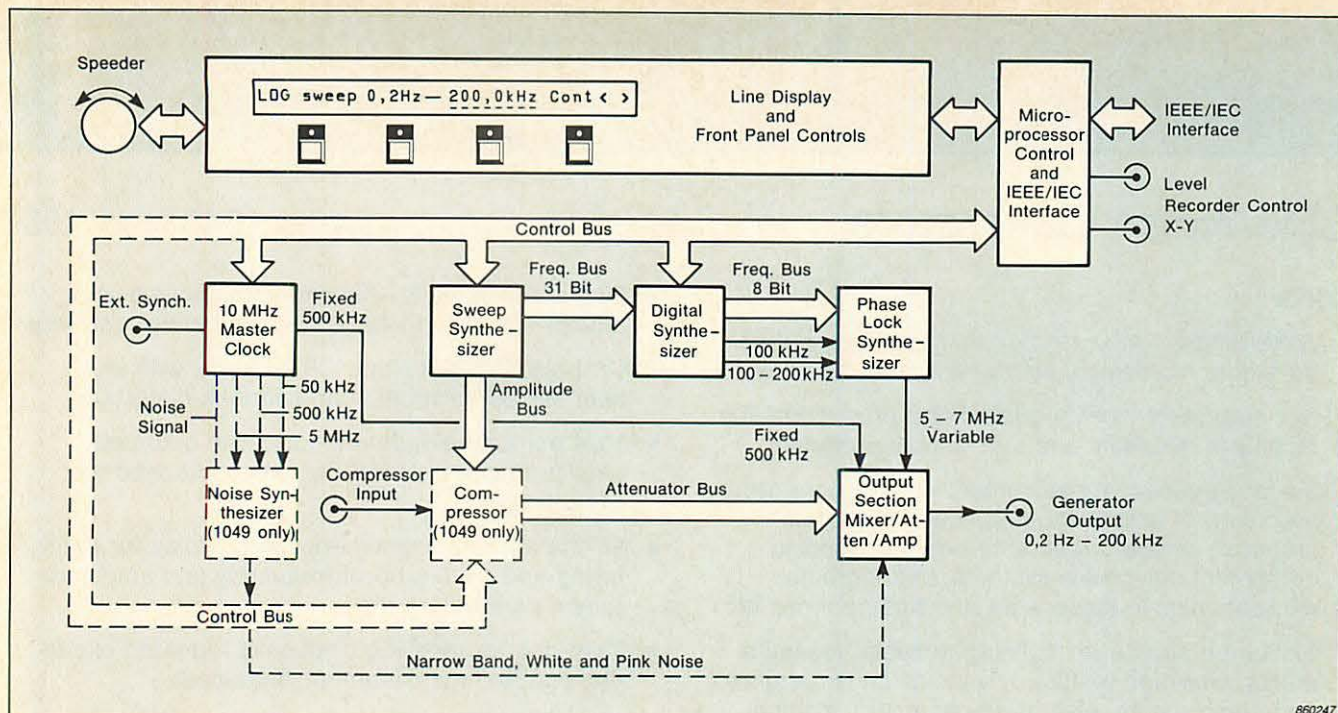

Fig. 1. Simplified block diagram of the B&K Sine/Noise Generator Type 1049 and Sine Generator Type 1051

Outputs levels from $100 \mu\text{V}$ to 5 V RMS may be chosen to 3 digits, permitting either a constant amplitude or an amplitude-weighted, frequency sweep to be obtained. With the latter up to 1024 amplitudes may be stored, which enable the Generators to simulate the output of record reproducer pick-ups, tape heads and electrical circuits etc. Also, equalization characteristics can be stored for maintaining a constant sound pressure or vibration output with loudspeakers and vibration exciters.

All functions and parameters may be selected or entered by the front panel pushkeys or via the IEEE/IEC digital interface bus of the Generators. In addition, there is an analogue "speeder" knob for fast and precise continuous adjustment of parameters. Front panel set-up conditions are indicated on a 40-character line display, from which as many as four functions and their individual parameters may be monitored simultaneously.

If desired, nine sets of front panel set-up conditions may be stored and instantly recalled for performing frequently used excitation test and measurement sequences, as is normally called for in service and production testing of products. For automatic plotting of swept-frequency measurements and analyses, special provision is made for synchronizing level and X-Y recorders. Alternatively, where an

IEEE/IEC system controller is used for automatic control of the Generators, they may be coupled with a digital plotter.

In addition to the above, the Type 1049 has a number of extra facilities. These include a logarithmic amplitude sweep, as well as narrow-band random, white and pink noise outputs. Also, a compressor circuit is built in as an alternative means of obtaining a constant sound or vibration level output when a loudspeaker or vibration exciter is employed with the generator. In this case, however, external feedback is employed to provide active regulation of the generator output which has the benefit that it automatically takes into account the response of the exciter under actual test conditions.

Description

A simplified block diagram of the B&K Generators Types 1049 and 1051 is shown in Fig.1. They have 6 main sections, namely a Master Clock, a Digital Frequency Synthesizer, a Phase Lock Synthesizer, a Sweep Synthesizer and an Output Section, all of which operate under the guidance of a Microprocessor Section which takes care of the user communication via the front panel controls and IEEE/IEC interface of the Generators. In addition, Type 1049 features a

Noise Generator and Compressor, which greatly increase its range of applications, especially for acoustic and vibration measurements.

Frequency Synthesizer

The Generators employ a heterodyne synthesis technique where a 500 kHz fixed frequency is mixed with a 500 to 700 kHz variable frequency to produce an 0,001 Hz to 200 kHz swept-frequency, sine-wave output with frequency resolution of 1 mHz. The 500 kHz fixed frequency is obtained from a Master Clock, while the 500 to 700 kHz variable frequency is derived from the 5 to 7 MHz output of a Phase Lock Synthesizer.

The Master Clock is based on a highly stable 10 MHz crystal oscillator whose relative accuracy is transferred to the output frequency. If an even greater accuracy is required the internal oscillator can be phase locked with an external reference which may be coupled to an Ext. Sync. socket on the rear panel. See Fig.2.

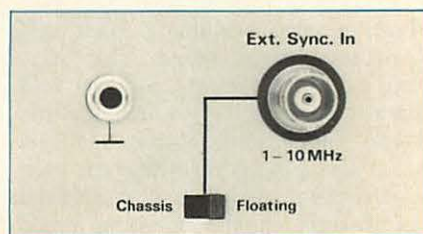

Fig. 2. Ext. Sync. Input of the 1049 and 1051 Generators

For a 5 to 7 MHz variable frequency proportional to the generator output frequency, a 31 bit frequency control output from the Sweep Synthesizer is utilized. To achieve a wide sweep range while maintaining a high accuracy and resolution, the Sweep Synthesizer output is split into two components. The lowest 23 bits are used to produce a 100 to 200 kHz variable control frequency proportional to the Hz and mHz frequency setting of the Generators, while the remaining 8 bits are used to produce a 49,9 to 69,9 MHz control frequency proportional to the kHz setting.

The respective control frequencies are generated by a digital synthesis and a divide by "N" phase lock loop. They are then summed by another phase lock loop to produce a 50 to 70 MHz control frequency which after application to a 10:1 frequency divider in the Phase Lock Synthesizer is fed to the Output Section where the final stages of frequency conversion take place. The use of two phase lock loops for producing 50 to 70 MHz control frequency, ensures that phase noise is kept to a minimum.

Output Section

From the Phase Lock Synthesizer the 5 to 7 MHz control frequency is applied to a second 10:1 frequency divider which is included at the input of the mixer stage of the Output Section. The output is then mixed with the 500 kHz output of the Master Clock to produce a sine-wave signal whose frequency corresponds directly to the frequency indicated on the display of the Generators. For removing unwanted side-band components in the mixed signal, a 280 kHz low-pass filter is employed.

Before application to the outputs of the Generators the filtered sine-wave signal is fed to an attenuator and amplifier for amplitude conditioning. The output attenuator gives an overall attenuation of 16 bits enabling the

fraction and exponent of the output level to be accurately set within 3 digits from 100 μ V to 5,00 V RMS via the front panel controls and interface bus of the Generators.

The Output Amplifier provides two low impedance signal outputs, which are made available at a BNC socket on the front and rear panels. These may be matched with 50 Ω signal lines and to suit the individual grounding requirements of different measurement and test systems may be isolated or connected to chassis by means of a slider switch on the rear panel. See Fig. 2.

In the design of the Generators, particular attention has been paid to obtaining very low signal distortion and good amplitude linearity. At frequencies between 20 Hz and 20 kHz, the maximum harmonic and spurious distortion is more than -96 dB down, with typical second and third harmonic distortion components -105 dB down at 800 Hz.

The amplitude linearity of the output is better than $\pm 0,05$ dB at frequencies between 20 Hz and 20 kHz, decreasing to $\pm 0,2$ dB at 0,2 Hz and 200 kHz. At lower frequencies the amplitude falls by 20 dB per decade, but by utilizing the "Memory Learn" function of the Generators to maintain a constant output level of 300 mV or less, a flat amplitude characteristic can be maintained at all frequencies down to 0,001 Hz.

Sweep Synthesizer

The Sweep Synthesizer includes a ramp register which produces a 31 bit output representing the frequency setting of the Generators. The frequency may be set by an input either from the front panel keyboard or via the interface bus of the Generators. For a frequency sweep, however, an internal clock signal is used, enabling either "Linear" or "Logarithmic" frequency sweeps to be chosen with sweep rates from 0,001 Hz/s to 999,9 kHz/s and 0,001 mDecade/s to 2 Decade/s, respectively.

With linear and logarithmic frequency sweeps, six or more complete frequency decades can be covered in a single range. The logarithmic sweep range extends from 0,2 Hz up to 200 kHz, while the linear sweep range is from 0,001 Hz up to 200 kHz, however, either can be independently set to any lower or upper frequency limit within these ranges if so desired.

In addition to the above, "Up", "Down", "Up/Down", "Single", "Repetitive" (1 to 99) and "Continuous" sweeps modes may be chosen. Also there is a "Pause" function whereby a preset delay of between 0 and 100 s may be included between each consecutive sweep.

A particularly useful feature is that the Generators automatically compute the time for a single sweep. The sweep time is indicated directly on the front panel display and automatically takes into account the particular frequency limits and sweep rate chosen. With single and repetitive Up/Down sweeps a minimum sweep time of 8 ms can be achieved, while with sweeps including pause or those in one direction, sweep times as short as 62,5 μ s are possible.

Amplitude Memory

Besides a ramp register for frequency synthesis, the Sweep Synthesizer contains an amplitude register for controlling the Output Section Attenuator.

For manual setting of the output level, the amplitude register accepts a numeric input from the front panel keyboard or a digital input applied over the interface bus of the Generators. The input may be applied directly to the amplitude register or, if the "Memory Learn" function is used, via the internal memory of the Generators. In the latter case, up to 1024 amplitudes can be stored for successive frequencies within any desired frequency range of the Generators, and when recalled enable almost any type of single or repetitive, amplitude weighted, frequency sweep to be generated.

The "Memory Learn" function is of particular benefit for swept frequency sound and vibration measurements. When one of the Generators is employed to drive a loudspeaker or vibration exciter, for example, its output level can be weighted according to the dynamic response of the loudspeaker or vibration exciter so that a constant sound pressure or vibration level output is maintained over the entire frequency range of interest.

To save entry of each individual level manually, the "Memory Learn" function includes automatic amplitude interpolation between consecutive amplitudes input. Alternatively, amplitudes may be entered as a voltage signal via the Compressor Input of the 1049.

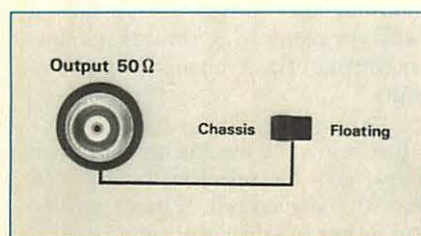

Fig. 3. BNC Output and Chassis/Floating switch of the 1049 and 1051

Additional Features Type 1049

Noise Generator

In the Sine/Random Generator Type 1049 wide band, pseudo random noise of very even spectral density is generated by two long shift registers followed by a low- and high-pass filter. The noise signal has a symmetrical gaussian amplitude distribution up to $4,5 \sigma$ with upper frequency limit, line spacing and sequence length depending on the shift register clock frequency. See "Specifications".

By selecting the appropriate -0,5 dB lower and upper frequencies of the filters, nine combinations of white noise can be obtained, ranging from 2, 20 or 200 Hz up to 2, 20 or 200 kHz. The filters are 3-pole Chebyshev types giving less than 0,1 dB ripple and an 18 dB/octave low- and high-frequency roll-off. For a pink noise output over the same frequency ranges, the white noise signal is fed through a -3 dB/octave filter before being applied to the attenuator and amplifier stages of the Output Section.

For a swept-frequency, narrow-band noise output, the white noise signal is fed to a balanced modulator circuit. This produces two DC to 1,25 kHz noise signals with relative phase of 0 and 90° which are applied to two identical low-pass filters. The filters are 3-pole Butterworth type which have a high frequency attenua-

tion slope of 18 dB/octave with selectable cut-off frequency of exactly half the particular noise bandwidth chosen on the Generator.

From the low-pass filters the two signals are mixed to produce two complementary signals which on an amplitude basis represent each half of the narrow-band noise characteristic shown in Fig.4, but with centre frequency of 500 kHz. The two signals are then combined and fed to the 500 to 700 kHz mixer stage of the Output Section where they are converted to a swept-frequency, narrow-band, noise output operating over the same sweep range as the sine-wave output of the Generator.

Because of the high crest factor of the narrow-band, white and pink noise generated by the 1049, the noise is attenuated by 12 dB (factor of 4) with respect to the sine output. The generator automatically accounts for this, so that the exact output level in the noise as well as the sine modes is displayed.

Compressor

As an alternative means of maintaining a constant output level with a loudspeaker or vibration exciter, the 1049 includes a Compressor. This enables a "live" control signal from an external preamplifier and measurement transducer to be used to automatically regulate and weight the output level of the Generator according to the dynamic characteristics of the loudspeaker or vibration exciter under actual test conditions.

The Compressor comprises an Input Attenuator and RMS Detector, followed by a VCO and Voltage Comparator. The VCO is used to produce a variable-frequency clock signal which is proportional to the rate of change of the input signal and is fed to the amplitude sweep register for automatic control of the Output Attenuator. The decision as to whether an increasing or decreasing amount of compression is needed to maintain a constant excitation level is made by the Comparator, which actuates the up/down input of the amplitude register.

The Compressor is equally adapt at regulating the random noise as well as sine wave outputs of the 1049 and gives no regulation error when dwelling at a single frequency. In both modes regulation over a 126 dB range is achieved, relative to a maximum output level of 5 V RMS.

The amount of compression is adjustable over a wide range using the Input Attenuator and either the input level or the amount of compression can be monitored directly on the 1049. For regulating low frequency signals without distorting the signal waveform, as well as counteracting excitation peaks of loudspeakers and vibration exciters, there is a choice of eight compressor speeds ranging from 0,3 to 1000 dB/s.

Amplitude Sweep

Also available with the 1049 is a logarithmic amplitude sweep. This may be chosen in place of a frequency sweep and is useful for investigating the electrical limiting and delimiting characteristics of audio recording and reproducing equipment, plus studying the dynamic behaviour of loudspeakers, earphones and telephone handsets. For these applications, either the random noise or sine output may be employed and the output level swept up and down with a sweep rate between 0,01 and 999 dB/s which may be set in accurate 0,1 dB/s steps.

As with the Compressor, the amplitude sweep is obtained by utilizing the amplitude register of the Sweep Synthesizer to automatically step the Output Section Attenuator of the 1049. In this case, however, a separate clock signal is applied whose frequency determines the particular sweep rate selected. The amplitude resolution of the sweep is better than 0,1 dB.

Monitoring and Set-Up Adjustments

Display and Field Entry

For convenient setting-up and monitoring of control settings, frequency sweep and output voltage limits etc., the front panel is furnished with a 40-character vacuum fluorescent line display plus a keyboard for selection of set-up and operating modes (see Figs.5 and 6). Depending on the particular set-up and operating mode chosen, the display is capable of indicating as many as four control settings simultaneously which also makes it useful for monitoring control parameters during the course of measurements.

Just below the display are four Field Select keys for selecting control settings to be changed. These may be used either to select and set a particular control setting directly, enabling a

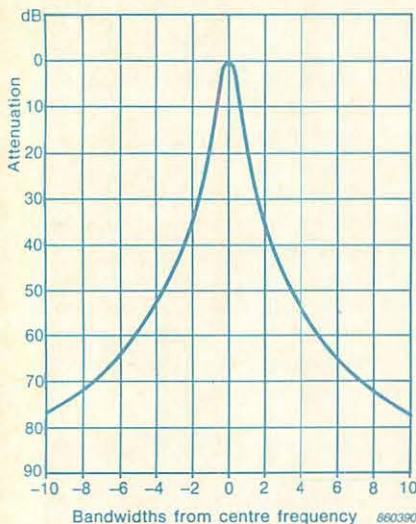

Fig. 4. Pass band of the 1; 3,16; 10; 31,6; 100 and 316 Hz narrow-band noise bandwidths of the 1049

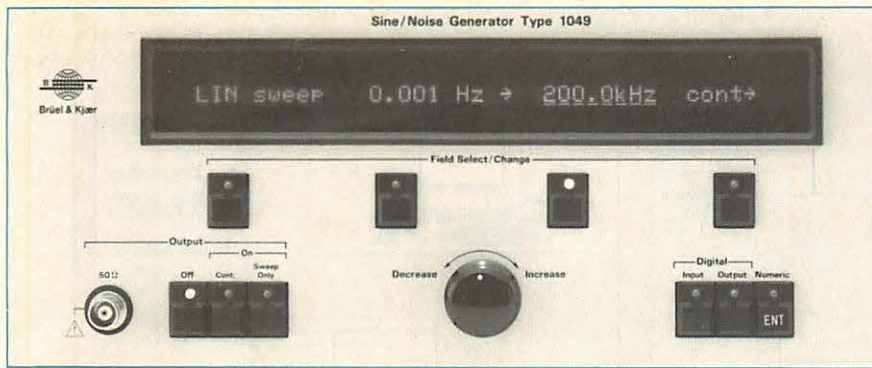

Fig. 5. Vacuum fluorescent line display, plus the field select and speeder controls of the 1049 and 1051

linear sweep to be changed to a logarithmic sweep for example, or for increasing the number of digits by which the frequency may be entered using the numeric pushkeys on the right of the front panel. Alternatively, the frequency and amplitude limits may be altered by employing the Speeder knob which is located beneath the Field Select keys.

The Speeder emulates the function of the coarse and fine tuning knobs of analog types of generator. Turning the knob a fraction to the left or right gradually decreases or increases the displayed frequency or amplitude limit, while a proportionately larger turn increases the speed at which the displayed value is altered.

Operating Set-Ups

When first switched on the Generators are automatically set to the control settings selected during previous use. The settings are stored in a continuous memory which is capable of storing 9 complete sets of front panel settings or setups so that a number of exciter control programmes may be kept on hand for performing frequently repeated swept frequency tests and measurements.

The individual setups may be instantly recalled whenever desired, simply by entering their set-up number. Provided that the internal battery for the memory is kept charged by subjecting the Generators to 4 to 8 hours use per week, then the set-ups may be retained more or less indefinitely, even when mains power is disconnected. See the "Specifications" section.

If required an entire setup may be copied in another setup so that only a limited number of control settings changes need be made to obtain a new setup suited to a specific test or task.

Where more than 9 setups are required, they may be stored externally using a digital tape or disk station and input over the digital interface of the Generators.

Interfacing

Digital Interface

The digital interface of the 1049 and 1051 conforms with the IEEE Std. 488-1978, and is fully compatible with the IEC 625-1 standard. It may be interconnected with as many as 15 separate instruments at one time, thus enabling numerous fully integrated test and measurement systems to be built which may be operated via a desk top calculator, personal computer or purpose built controller.

The interface has a full Talker (T5) and Listener (L3) capability, permitting remote sensing and selection of the generator controls, plus printing of the control status. As with other B & K instruments, the interface accepts easy to interpret acronyms as well as complete control names for commands, thus enabling users to setup their own fully automatic control sequences with the minimum of programming experience.

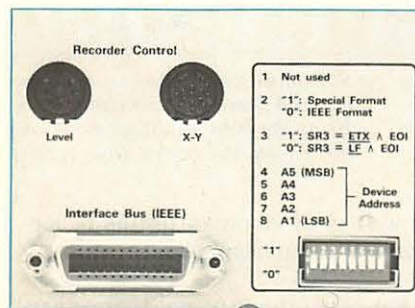

Fig. 7. The Recorder and Digital Interface connectors of the 1049 and 1051

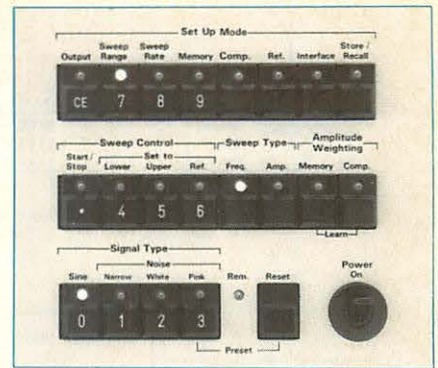

Fig. 6. The Setup Mode, Sweep and Signal keys of the 1049

Recorder Interface

For graphic recording of swept frequency tests and measurements analog outputs are available for coupling level or X-Y recorders. These are shown in Fig. 7 and provide the necessary control voltages for synchronous recording over a maximum of six frequency decades with either the B & K Level Recorder Type 2307 or X-Y Recorder Type 2308. For operation with the B & K Portable Level Recorders Type 2309 and 2317 manual synchronization is possible because of the very accurate sweep timing possibilities with the Generators.

With X-Y Recorders, recordings can be made on linearly or logarithmically graduated paper, irrespective of which type of frequency sweep is chosen on the Generators. Also plotting of forward and reverse frequency sweeps is possible and for tape recorder and acoustic investigations the X-Y synchronization can be delayed between 0 and 1 s in 10 ms steps to coincide with the arrival of the measured signal. For continuous monitoring of measurements the wide choice of sweep rates of the Generators enable the X-Y output to be used to control an oscilloscope.

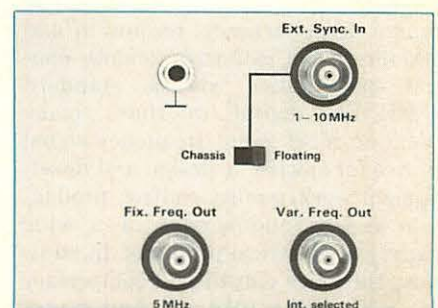

Fig. 8. The Fixed and Variable Freq. Outputs, plus the Ext. Sync. Input

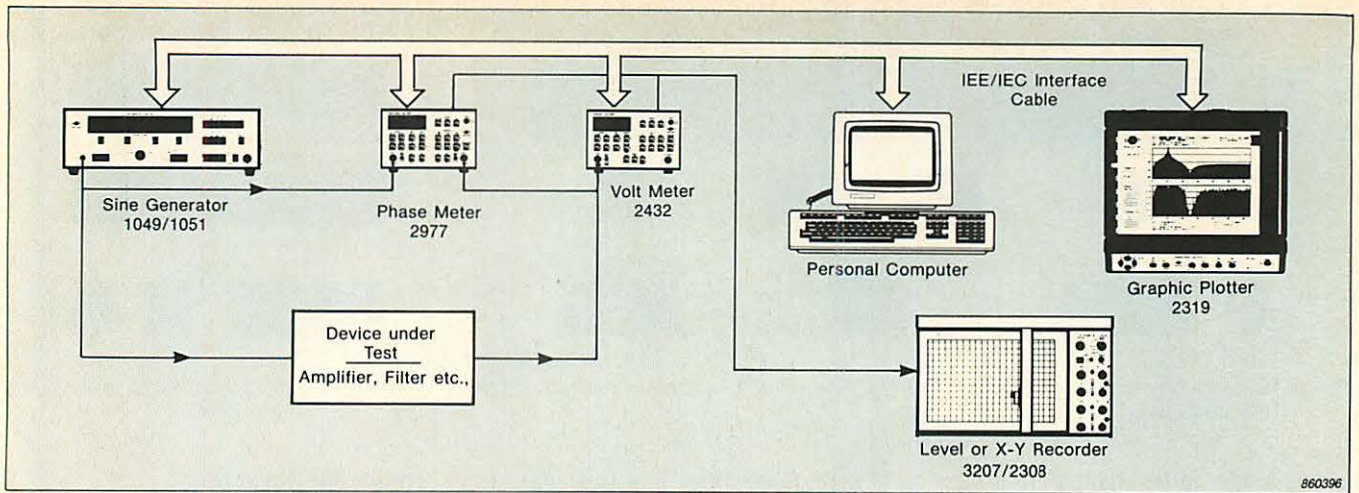

Fig. 9. Instrument arrangement for frequency response and phase measurements on audio recording and reproducing equipment. Using their internal memory for preconditioning, the 1049 and 1051 Generators can simulate a record pick-up, tape head, preamplifier equalization network output etc.

Auxiliary Outputs

Supplementing the sine-wave and noise outputs of the Generators is a square wave output. This provides a 1 mHz to 200 kHz TTL signal corresponding with the frequency setting of the Generators which will be found ideal for pulse testing of electronic measuring, recording and reproducing equipment.

Also available with the Generators are a fixed frequency (5 MHz) and a variable frequency (5 - 7 MHz/50 - 70 MHz user selected) output which may be used as clock references for external equipment. For locking the internal clock of the Generators with an external source, a Synch. Input is provided which accepts a 10 MHz signal or an appropriate sub-harmonic. See "Specifications".

Examples of Use

Because of their ultra high performance capability and extreme operating flexibility, the Sine Generators Types 1049 and 1051 can be used for a very wide range of applications.

Their wide frequency and dynamic ranges, high accuracy, resolution and stability, plus extensive remote control possibilities via a standard IEEE/IEC digital interface, make them an ideal swept frequency signal source for electronic design and development work, quality control, production testing and service of a wide variety of electrical products. In addition, the noise output and compressor facilities of the 1049 will find extensive applications in electro-acoustic and building acoustic investigations,

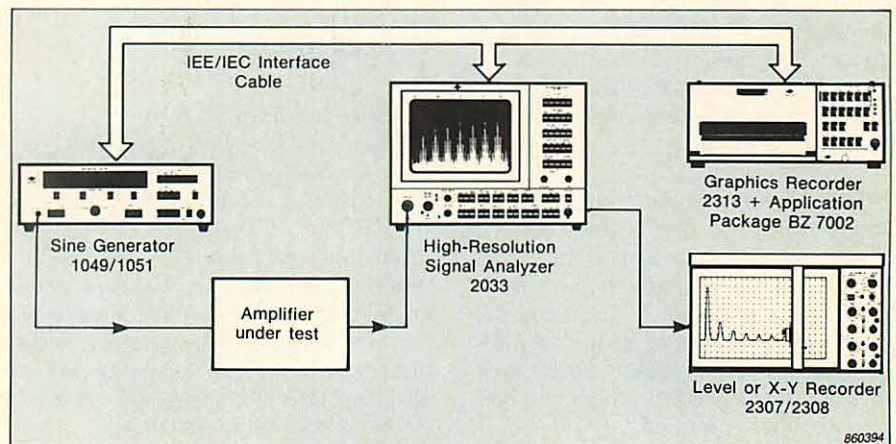

Fig. 10. Harmonic and intermodulation distortion measurements using the 1049 or 1051 Generator with the 2033 High-Resolution Signal Analyzer

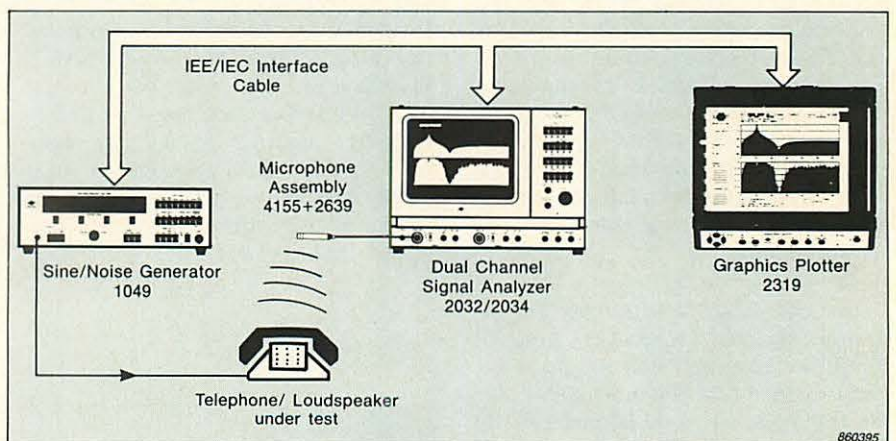

Fig. 11. Simulated free-field measurements on electro-acoustic devices using the noise output and Start/Stop function of the 1049 Generator to create random noise bursts. Using the 1049 amplitude sweep, a similar arrangement may be used for measuring the attack and release time of telephone equipment, loudspeakers etc.

as well as in vibration testing of mechanical components and structures.

For use of the 1049 and 1051 as part of a much larger measurement system Brüel & Kjær markets a range of ana-

logue and digital equipment. These include the Digital Voltmeter Type 2432, Digital Phase Meter Type 2977, Digital Frequency Analyzer Type 2131, High Resolution Signal Analyzer Type 2033 and Dual Channel Signal

Analyzers Type 2032 and 2034 which are especially designed for a wide variety of response measurements and frequency analyses. For storage and documentation of results the Digital Cassette Recorder Type 7400, plus Graphics Recorder and Plotter Type 2313 and 2319 are available.

As with the Generators, all the digital equipment mentioned can be controlled via a terminal, personal computer or purpose built system con-

troller which features an IEEE/IEC interface. This makes them ideal for use in laboratory, production and environmental testing where very many simple as well as complex swept frequency performance tests and calibration checks have to be carried out which are of a repetitive nature. Here it is useful that tests are carried out on an automatic basis using a personal computer or system controller to control the entire test setup. Also, a personal computer can be used for re-

formatting measured data to produce a hardcopy readout of frequency, phase and amplitude responses etc., with a graphics recorder or plotter. In more advanced systems a computer may be used to decide on whether test results are within acceptable limits as well as to diagnose faults.

For further details on the B & K equipment mentioned, please consult the B & K Short-Form or Master Catalogues.

Specifications 1049/1051

SINE GENERATOR:

Frequency Range: 0.2 Hz to 200 kHz. The generator can be used at frequencies down to 0.001 Hz. See "Amplitude Linearity" Spec.
Frequency Resolution: 0.001 Hz
Frequency Accuracy: ± 0.1192 mHz
Frequency Stability: < 25 ppm from 10 to 40°C with < 5 ppm aging per year

Harmonic and Spurious Distortion:

< -96 dB from 20 Hz to 20 kHz
 < -85 dB from 0.2 Hz to 200 kHz

Phase and A.M. Noise: < 85 dB in a 200 kHz band (excluding 1 Hz band) centred on carrier with 5 V max. output

Amplitude Linearity:

± 0.05 dB from 20 Hz to 20 kHz
 ± 0.2 dB from 0.2 Hz to 200 kHz
 -3 dB limit ~ 0.01 Hz with 20 dB/decade attenuation slope down to 0.001 Hz

GENERATOR OUTPUTS:

Via BNC sockets on front and rear panel
Output Voltage: 100 μ V to 5 V RMS selectable to 3-digits with $\pm 0.2\%$ relative attenuator accuracy. Output readout based on no-load condition
Output Impedance: 50 Ω
Grounding: Chassis/Floating (0.1 V max.)

OUTPUT On/Off:

Fast: < 0.1 ms rise and decay time
Slow: ~ 30 ms for raising and suppressing output signal 60 dB

AMPLITUDE LEARN:

1024 amplitudes can be memorized within any given frequency range and later recalled for successive single or repetitive frequency sweeps. Amplitudes may be input numerically via the front panel pushkeys, digitally via the IEEE/IEC interface or as a voltage input to the 1049 compressor. Includes automatic amplitude interpolation between consecutive amplitudes input

FREQUENCY SWEEP:

Linear/Logarithmic with or without amplitude weighting via amplitude learn function

Sweep Limits: from 0.2 Hz to 200 kHz, selectable to 4 digits. In extended range 0.001 Hz to 200 kHz linear sweep. The limits will be reached within the resolution of the programmed stop frequency ± 0.001 Hz

Sweep Rate:

Linear: 0.001 Hz/s to 999.9 kHz/s selectable to 4 digits with $\pm 2^{-15}$ accuracy
Logarithmic: 0.001 mDec/s to 2,000 Dec/s selectable to 4 digits with $\pm 2^{-15} \pm 0.2\%$ per Dec/s accuracy

Sweep Resolution:

Linear: < 1 mHz at rate $< 4,768$ kHz/s or < 0.244 Hz at rate $> 4,768$ kHz/s
Logarithmic: < 1 mHz at rate $< 8,089$ mDec/s or frequencies < 1 kHz. 0.244 Hz outside the above limits

Sweep Modes: Up, Down, Up and Down, Single, Repetitive 1 - 99 times and Continuous are selectable

Amplitude Weighting: 1024 amplitude levels can be played back during the frequency sweep. See "AMPLITUDE LEARN" Spec.

Sweep Pause: 0.00 to 100.0 s pause between repetitive sweeps selectable with 10 ms resolution or 0.1% accuracy whichever is the greatest

Pause Output: Output may be set "On" or "Off" between repetitive sweeps

Control Limits: Sweep on may be individually preset to reference or any preset lower and upper frequency or amplitude limit dependent on sweep type

Sweep Time: Computes and displays time for single sweep between particular lower and upper limit and sweep rate selected. Minimum single sweep time is 8 ms for repetitive Up/Down sweeps and 62.5 μ s for sweeps including pause or those in one direction

LINE DISPLAY:

40-character, vacuum fluorescent, line display with 4 display fields for entry and storage of generator control settings, as well as simultaneous monitoring of generator output frequency, output voltage, compressor voltage, etc.

TEST PROGRAMMES:

Non volatile memory for entry, storage and recall of front panel control settings. Enables 9 user-defined control sequences to be stored and instantly recalled for electronic, electro-acoustic and vibration test work. Memory backup battery enables stored settings to be retained 1 month with 8 hours use of the Generators

AUXILIARY INPUTS/OUTPUTS:

Via separate BNC sockets on rear panel
Square Output: TTL square wave output of generator frequency from 1 mHz to 200 kHz
Ext. Synch. In: For phase locking internal clock with external signal source

Input Freq: 10 MHz down to tenth sub-harmonic

Input Voltage: 0.6 to 30 V Peak-to-Peak
Tuning Range: ± 100 ppm

Ground: Chassis/Floating (0.1 V max)

Fix. Freq. Out: 5 MHz sine-wave output reference frequency

Output Voltage: 0.6 V Peak-to-Peak

Output Impedance: 200 Ω

Var. Freq. Out: User selected 5 to 7 MHz or 50 to 70 MHz output depending on generator frequency

Output Voltage: 0.6 V Peak-to-Peak

Output Impedance: 25 Ω

Sweep Start: TTL output for trigger recording

RECORDER INTERFACE:

Level Recorder: 7-pin DIN socket providing remote control of start, stop, automatic stop and pen lift

X-Y Recorder: 8-pin DIN socket providing remote control of pen lift and X-deflection

Voltage Ramp: 0 to 10 V for X-deflection 12 bit D/A Converter. Accuracy 10 bit. 200 Hz sample frequency

Ramp Voltage Limits:

Lin. or Log. voltage ramp selectable for either Lin. or Log. frequency sweep

Lin. Ramp: 0 to 10 V for any lower or upper frequency limit from 0 Hz to 200 kHz or fixed limits of 0 Hz to 200 Hz, 0 Hz to 2 kHz, 0 Hz to 20 kHz and 0 Hz to 200 kHz

Log. Ramp: 0 to 10 V ramp for any lower or upper frequency limit from 0.2 Hz to 200 kHz or fixed limits of 0.2 Hz to 200 kHz, 2 Hz to 2 kHz, 20 Hz to 20 kHz and 200 Hz to 200 kHz

Amp. Ramp (1049 only): 0 V to 10 V for any lower or upper amplitude limit from 40 to 140 dB μ V or fixed limits of 40 to 100 dB μ V, 60 to 120 dB μ V and 80 to 140 dB μ V

Ramp Delay: 0.00 to 1.00 s selectable with resolution down to 0.01 s

IEEE/IEC DIGITAL INTERFACE:

Conforms to IEEE 488 and IEC 625-1 standards. Connection into an IEC interface system is made using cable AO 0264 or cable AO 0194 and Adaptor AO 0195. Connection into an IEEE interface system is made using cable AO 0265.

Functions Implemented: Source Handshake (SH 1), Acceptor Handshake (AH 1), Talker (T 5), Listener (L 3), Service Request (SR 1), Remote Local (RL 1), Parallel Poll (PP 0), Device Clear (DC 1), Device Trigger (DT 1), Controller (C 0)

Data Output: Generator frequency, output level etc., plus all front panel control settings

Remote Control: All functions and instrument front panel settings can be remotely controlled via the digital interface

Code: ISO 7 bit code

GENERAL

Warm-Up Time: ~20 minutes

Temperature Range:

Operation: 10 to 40°C (50 to 104°F)

Max. Humidity: 90% RH (non condensing) at 30°C

Electromagnetic Compatibility: Complies with Class B Device of the American FCC Rules

Power Requirements: Complies with IEC 348 Safety Class II

Supply Voltage: 100; 115; 127; 200; 220; 240 V AC (50 to 60 Hz) ±10%

Consumption: 50 VA

Cabinet: Supplied as Model A (light-weight metal cabinet) or Model C (as A but with flanges for standard 19 in rack)

Dimensions: Metal cabinet, excluding knobs and feet

Height: 177 mm (5,2 in)

Width: 430 mm (16,9 in)

Depth: 320 mm (12,6 in)

Weight:

Type 1049: 11,6 kg (25,5 lb)

Type 1051: 11,1 kg (24,5 lb)

ACCESSORIES INCLUDED:

1 × Mains Cable AN 0020

1 × BNC Plug JP 0035

1 × 24-pin IEEE Std. 488

Bus Connector Kit..... UA 0814

2 × 250 mA Fuse VF 0031

2 × 500 mA Fuse VF 0023

ACCESSORIES AVAILABLE:

IEC 625-1 to IEEE 488

Interface Cable (2 m) AO 0264

IEEE 488 Interface Cable (2 m)..... AO 0265

X-Y Recorder

Control Cable (1,5 m)..... AQ 0034

Level Recorder

Control Cable (1,5 m)..... AQ 0035

Additional Specifications 1049

NOISE GENERATOR:

Generator Type: Pseudo Random

Distribution: Symmetrical Gaussian amplitude distribution up to $4,5\sigma$

Line Spacing and Sequence Length:

Upper Limit	2 kHz	20 kHz	200 kHz
Line Spacing	11,37 nHz	113,7 nHz	1,137 μHz
Sequence Length	24434 H	2443 H	244,3 H

T01029GB0

Spurious Distortion: As for Sine Generator +12 dB

Spectral Flatness: ±0,5 dB within freq. range

Output Voltage: As for Sine Generator -12 dB

Narrow-Band Random Mode:

Centre Frequency: As for Sine Generator

Noise Bandwidth: 1; 3,16; 10; 31,6; 100 and 316 Hz. Actual -3dB bandwidth 4,6% narrower than noise bandwidth

Filter Types: 3-pole Butterworth

White Noise Mode:

Frequency Range Limits:

Lower: 2; 20 and 200 Hz - 0,5 dB

1,4; 14 and 140 Hz noise limit. The actual -3dB lower limit is 4,6% greater

Upper: 2; 20 and 200 kHz - 0,5 dB

2,8; 28 and 280 kHz noise limit. The actual -3 dB upper limit is 4,6% less

Filter Type and Ripple: 3-pole Chebishev <0,1 dB ripple

Pink Noise Mode: As for White Noise Mode, but with -10 dB/decade attenuation above 2; 20 and 200 Hz lower limits

AMPLITUDE SWEEP:

Rate: 0,01 to 999 dB/s with resolution down to 0,1 dB and 2^{-8} to 2^{-14} accuracy

Switching: Amplitude sweep and compressor regulation causes small transients due to range switching at the following levels:

Down Sweep: 612,5 μV; 10 mV and 160 mV

Up Sweep: 1,25 mV; 20 mV and 320 mV

Sweep Limits: Selectable to 4 digits in whole amplitude range with 0,1 dBμV resolution

COMPRESSOR:

Speed: 0,3; 1; 3; 10; 30; 100; 300; and 1000 dB/s

Input Attenuator: 0,10 to 2,50 V accuracy 1%. 3 digit, 0,01 V resolution

Input Detector: RMS

Freq. Response: 2 Hz to 200 kHz ±0,2 dB

Dynamic Range: More than 126 dB below max. level