

Microphone Amplifiers Type 2603 and 2604

The Microphone Amplifiers Type 2603 and 2604 are accurate, multi-purpose instruments for use in the sound and vibration measuring field as well as in ultrasonic measurements. Both instruments consists basically of an input amplifier section, the proposed IEC standard weighting networks "A", "B" and "C" for Precision Sound Level Meters (Helsinki 1961), and an output amplifier section.

Provision is made for the insertion of external filters between the amplifier sections. An output terminal makes it possible to connect the Amplifiers to an a.c. recording instrument, e.g. the B & K Level Recorder Type 2305.

When used in connection with one of the B & K Condenser Microphones a **precision sound level meter** is obtained. The Amplifiers

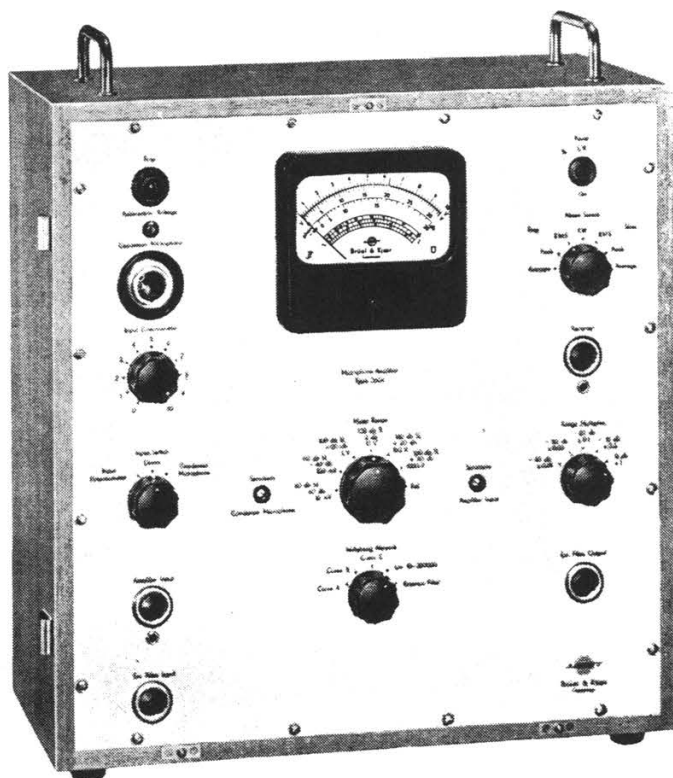

Fig. 1. Microphone Amplifier.

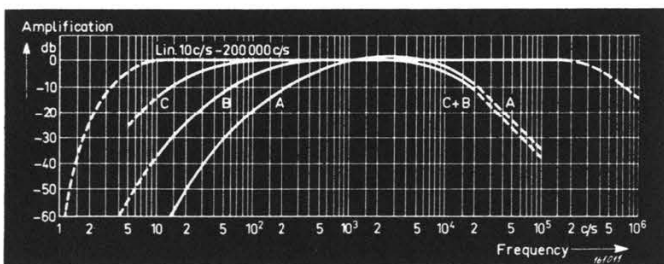
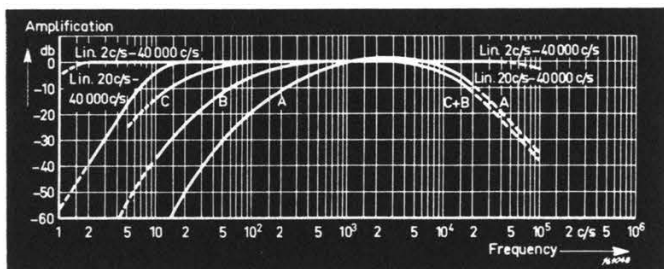

Fig. 2. Typical frequency characteristics of the Microphone Amplifiers.
a) Type 2603.
b) Type 2604.

can also be used as **calibrated amplifiers** with a linear frequency characteristic from 2 c/s to 40000 c/s for Type 2603 and from 10 c/s to 200000 c/s for Type 2604, and, additionally, as **a.c. vacuum-tube voltmeters**. An outstanding feature of the instrument is the possibility they offer to measure the **true R.M.S., the arithmetic average and the peak value** of the input signal. To enable easy meter readings for both rapidly and slowly varying signal levels two different and selectable meter damping characteristics are provided, both of which are in accordance with the proposed IEC standards for Precision Sound Level Meters.

DESCRIPTION

From the block diagram shown in Fig. 3 the basic design of the Amplifiers can be seen. The input amplifier section, which contains three amplifier stages, is supplied with a great amount of negative feedback to ensure high stability and low output impedance, approximately 10 ohms at the terminal marked "Filter Input". This terminal, together with

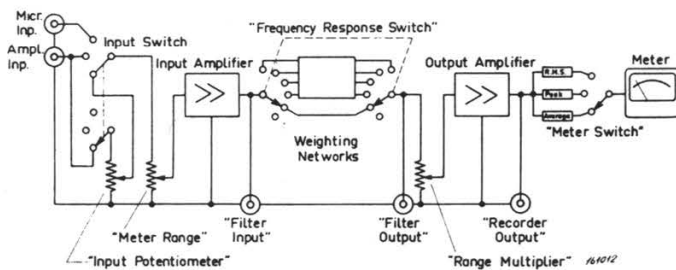

Fig. 3. Block diagram of the Amplifiers.

the one marked "Filter Output" is provided for insertion of external filters. Also, the "Filter Input" and "Filter Output" terminals allow separate use of the input and output amplifier sections. The input impedance at the "Filter Output" terminal is approximately 1.5 Mohms for Type 2603 and 150 Kohms for Type 2604.

The built-in weighting networks can be inserted between the two amplifier sections by operating a switch, which also allows the selection of the desired frequency characteristic of the Amplifier. Typical frequency characteristics are plotted in Fig. 2.

The output amplifier section contains, similar to the input amplifier section, three stages and is also supplied with a great amount of negative feedback.

When utilizing Type 2603 as a calibrated amplifier, the output voltage is fed to the terminal marked "Recorder".

When the Amplifier is used as a vacuum tube voltmeter, the desired type of rectification (peak, arithmetic average or R.M.S.) as well as the meter damping characteristic can be chosen by a switch in the output circuit of the instrument.

The true R.M.S. indication is obtained by approximating the square-law curve by straight line portions. The true reading is

accurate to within 0.5 db for the measurement of signals with crest values up to 5.

SENSITIVITY ADJUSTMENT

The sensitivity of the instruments is readily checked by applying a **built-in reference voltage**. Possible deviations from the proper sensitivity should be corrected by a screw-driver operated potentiometer accessible through holes in the front panel of the instrument. Separate and independent sensitivity controls are provided for the "Condenser Microphone Input" and the "Amplifier Input".

EXAMPLES OF APPLICATION

PRECISION SOUND LEVEL MEASUREMENTS

Fig. 4 shows a measuring arrangement in which the Amplifier Type 2603 is used as a precision sound level meter.

To correctly measure the sound level, the instrument should be switched to indicate the R.M.S. value of the input signal and one of the weighting networks "A", "B" or "C" be inserted.

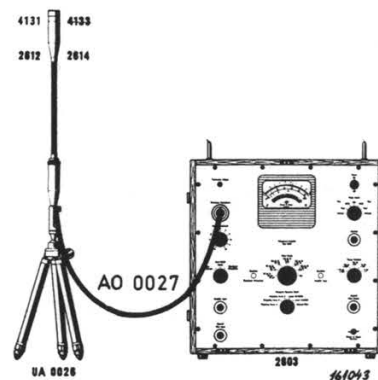

Fig. 4. Set-up for precision sound level measurements.

Before use the measuring arrangement can be readily calibrated by using the Pistonphone Type 4220, or, if high precision is not demanded, the Noise Source Type 4240 can be utilized for checking. These instruments produce a certain specified sound pressure level at the microphone diaphragm and are very useful aids in the field of noise investigation.

RECORDING OF NOISE

In many workshops or offices the noise level varies considerably with time. If the noise level is measured in such places by a single reading, a serious error may be introduced. In such cases it may be necessary to record the noise level over a relatively long period of

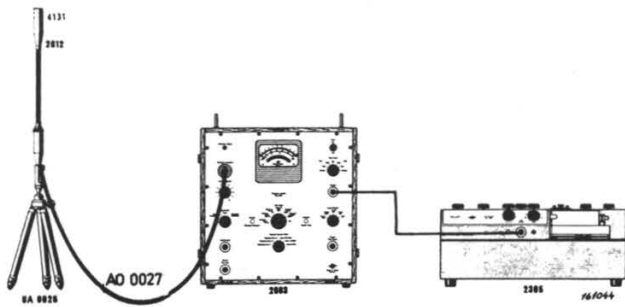

Fig. 5. Set-up for recording of noise levels.

time. A satisfactory average figure can then be obtained and noise peaks be observed, as these are of particular interest from a health point of view.

Fig. 5 shows a measuring set-up by which a continuous recording of the noise level can be made, and in Fig. 6 the result of measurements taken in a mechanical workshop is shown.

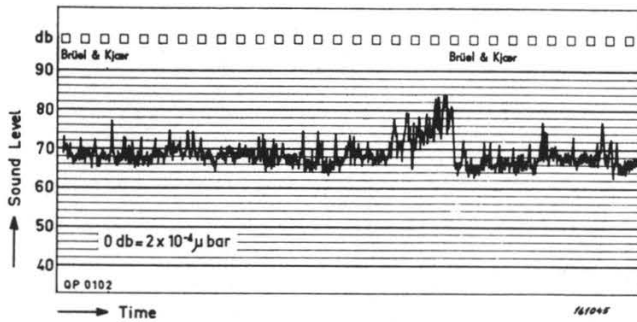

Fig. 6. Recording of the noise level in a mechanical workshop as a function of time, obtained by means of the set-up shown in Fig. 5.

DISTORTION MEASUREMENTS

The nonlinear distortion in four-terminal networks is normally expressed by the formula:

$$d \approx 100 \frac{\sqrt{A_2^2 + A_3^2 + A_4^2 + \dots}}{A_1} \%$$

When the Microphone Amplifier Type 2604 is used together with the Frequency and Distortion Measuring Bridge Type 1607 it forms a convenient distortion meter, on which the factor d can be read directly in per cent in one reading.

Type 1607 is basically a variable rejecting network, by which means any frequency in the range 20 c/s to 20000 c/s can be attenuated by more than 80 db, while all other frequencies are allowed to pass the network without or with a specified degree of attenuation. The Distortion Bridge can be connected to the "Filter Input" and "Filter Output" terminals of Type 2604. With an arrangement as shown in Fig. 7 distortion factors down to 0.5 % can be measured.

NOTE: The instrument must be switched to measure the RMS value of the signal.

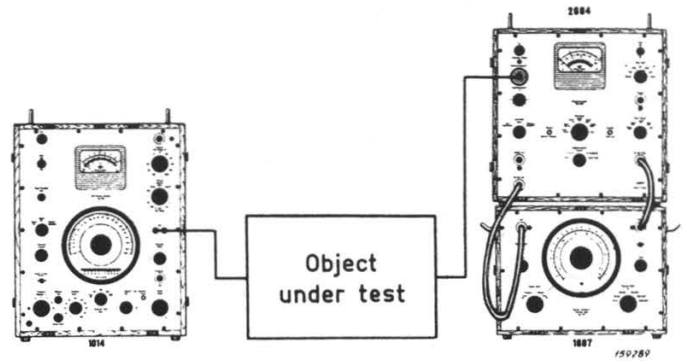

Fig. 7. Measuring arrangement for distortion measurements.

RECORDING THE FREQUENCY RESPONSE OF HYDROPHONES

The Amplifier Type 2604 is a very convenient instrument for measurements in the ultrasonic range, for example when the characteristics of hydrophones are measured. In Fig. 8 is shown an arrangement for automatic recording of the frequency response of a hydrophone. A B & K Beat Frequency Oscillator Type 1013 is here used as signal source for the projector, and the signal from the hydrophone under test is via Amplifier Type 2604 fed to the Level Recorder Type 2305. The signal from the regulating hydrophone is, when amplified, by another

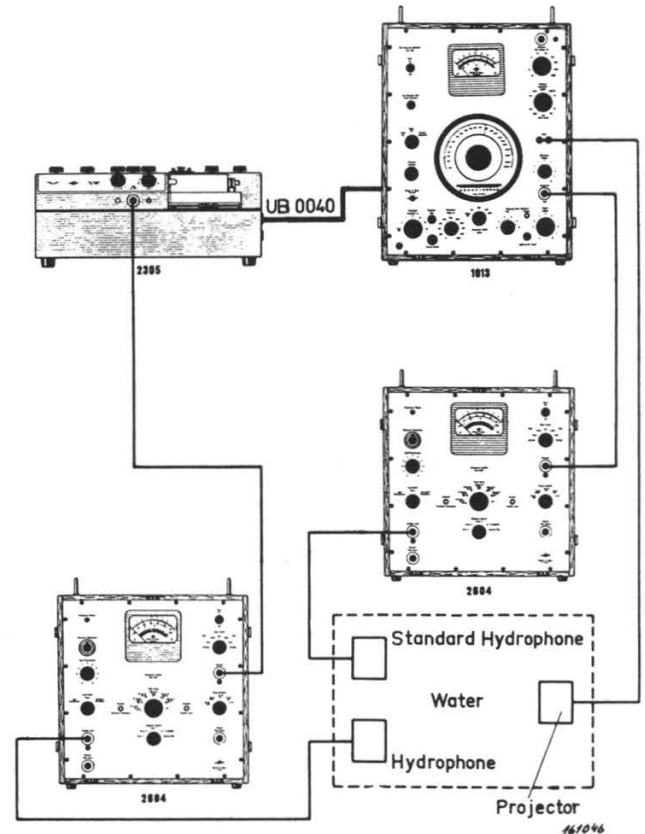

Fig. 8. Recording the frequency response of a hydrophone.

Amplifier Type 2604 applied to the regulating circuit of the B.F.O. This arrangement makes it possible to keep a constant reference sound pressure level at the symmetrically placed hydrophones.

With the aid of a mechanical connection (flexible shaft) the frequency scanning of the B.F.O. can be synchronized with the paper drive of the Level Recorder. In this manner the frequency response of the hydrophone being tested is recorded automatically on preprinted paper. In Fig. 9 is shown a typical frequency response curve of a piezoelectric type of hydrophone.

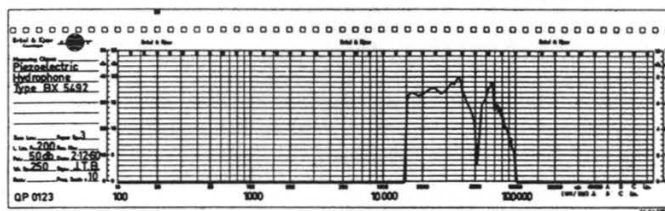

Fig. 9. Typical frequency response curve of a piezoelectric type hydrophone.

SPECIFICATION TYPE 2603

Frequency Characteristics:

“Linear”: 2 c/s to 40000 c/s to within ± 0.5 db (± 0.3 db in the range 5 c/s to 20000 c/s).

Weighting Networks:

“A”, “B” and “C”. Characteristics in accordance with the proposed IEC standards for Precision Sound Level Meters (Helsinki 1961).

“Lin”, gives linear range 20–40000 c/s. Cutting off below 20 c/s with a maximum slope of 18 db per octave.

Sensitivity: Max. 100 μ V full scale deflection. Min. 1000 volts. Variable in steps of 10 db.

Amplification: Max. 100 db. Amplifier noise referred to input and max. gain: Approx. 15 μ V with open input, and approx. 5 μ V with short-circuited input.

Input: Switch selection of three different input facilities:

1. “Direct”. Input impedance 2.2 M Ω paralleled by 30 pF.
2. “Input Potentiometer”. Input impedance approx. 1 M Ω . To be used for relative measurements.
3. “Condenser Microphone”. 7-poled socket for the B & K Condenser Microphones, Artificial Ears, and Pre-amplifiers.

Output: “Recorder”. Output impedance smaller than 50 Ω . Output voltage corresponding to full scale meter deflection approx. 10 V. Max. available output voltage approx. 45 V peak.

Meter: Conveniently illuminated instrument scale. Perfectly safeguarded against overload. Accuracy: Approx. 1 % of full scale deflection. Scales: 0–10 and 0–31.6 V (linear), 0–20 db (logarithmic) as well as 3 scales calibrated in % absorption for use in connection with the

Standing Wave Apparatus Type 4002.

Switch selection of two different meter damping characteristics in accordance with the proposed IEC standards for Precision Sound Level Meters.

Meter Rectifier: R.M.S., Arithmetic Average or Peak (half the peak-to-peak) type rectification can be selected by means of a switch.

Polarization Voltage: The polarization voltage for the Condenser Microphone Cartridges can be adjusted between 150 and 250 volts.

Tubes: ECC81 (12AT7) – ECC83 (12AX7) – EF94 (6AU6) – ECF82 (6U8) – EZ90 (6X4) – OA2 – OB2.

Power Supply: 100 – 115 – 127 – 150 – 220 – 240 volts a.c. 40–400 c/s. Power consumption is approx. 50 watts.

Cabinet: Mahogany cabinet with handles and lid.

Accessories included:

- 4 screened plugs JP 0018 matching the coaxial terminals,
- 1 power cable,
- various fuses and lamps.

Dimensions excl. dials and knobs	Height	Width	Depth
Centimetres	40	40	20
Inches	16	16	8
Weight	20 kg		45 lbs.

SPECIFICATION TYPE 2604

The specification for Type 2604 is similar to that of Type 2603 except for the following items:

Frequency Characteristics: “Linear”: 10 c/s to 200000 c/s to within ± 0.5 (± 0.3 db in the range 20 c/s to 100000 c/s).

Weighting Networks: No “Lin” (20–40000 c/s) characteristic.

Input: Switch selection of three different input facilities:

1. “Direct”. Input impedance 1.1 M Ω paralleled by 30 pF.

2. “Input Potentiometer”. Input impedance 0.5 M Ω approx. To be used for relative measurements.

3. “Condenser Microphone”. 7-poled socket for the B & K Condenser Microphones, Artificial Ears, and Pre-amplifiers.

Tubes: 2 \times ECC81 (12AT7) – EF94 (6AU6) – ECF82 (6U8) – EZ90 (6X4) – OA2 – OB2.

2. Identification of Control Knobs, Terminals etc.

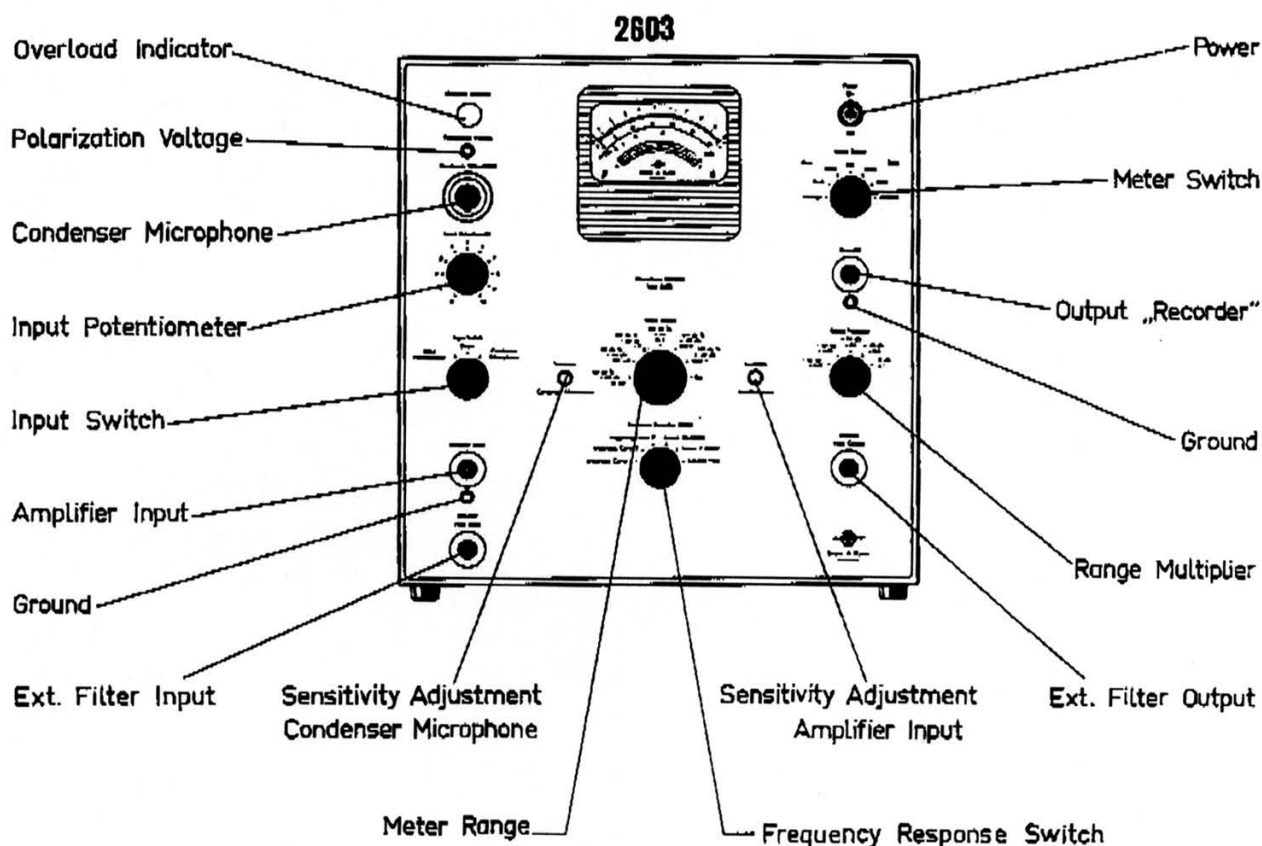

Fig. 2.1. Drawing of Type 2603 with control knob identification.

(Refer Fig. 2.1).

OVERLOAD INDICATOR:

Red light indicating that the input amplifier is overdriven (4.5 volts peak at the output of the input amplifier).

POLARIZATION VOLTAGE:

For measurement of the microphone polarization voltage. (The measurement should be carried out with a DC voltmeter having an internal resistance of at least 20000 Ω /volt).

CONDENSER MICROPHONE:

Input terminal for the B & K Microphones (and associated Cathode Follower). Also Preamplifier when used.

INPUT

POTENTIOMETER: For continuous variation of input signal attenuation.

INPUT SWITCH:

1. "Input Potentiometer", for use in relative measurements at the same frequency.
2. "Direct", the signal is then applied directly from AMPLIFIER INPUT to the attenuator METER RANGE.
3. "Condenser Microphone".

AMPLIFIER INPUT: The signal is applied to the attenuator METER RANGE either directly or via the INPUT POTENTIOMETER.

EXTERNAL FILTER INPUT: For connection of external filter (e.g. the Band-Pass Filter Set Type 1612).

SENSITIVITY, CONDENSER MICROPHONE: A screwdriver-adjusted potentiometer for adjustment of sensitivity when the input CONDENSER MICROPHONE is used.

METER RANGE: A stepped attenuator (20 dB) for attenuation of input signal.

FREQUENCY RESPONSE SWITCH: For the selection of linear amplification in the range 2—40000 Hz, the insertion of the built-in weighting networks A, B or C conforming to IEC recommendations for sound level measurements, or an external filter.

SENSITIVITY AMPLIFIER INPUT: Screwdriver-operated potentiometer for adjustment of sensitivity when terminal AMPLIFIER INPUT is used.

POWER: "On" and "Off" selection of power.

METER SWITCH: Selects three different rectifier and meter indicating properties:—

- "Average"
- "Peak" (i.e. half peak-to-peak)
- "RMS"

Positioned to right or left, high or low damping of the meter can be obtained. In position "Off" the meter is disconnected.

RECORDER: Output terminal for connection to monitoring instruments such as the Level Recorder Type 2305.

RANGE MULTIPLIER: Stepped attenuator (10 dB) for attenuation of the signal level between filter outputs and the output amplifier.

EXTERNAL FILTER OUTPUT: For use when utilizing external filter.

3. Operation

VOLTAGE MEASUREMENTS

Calibration.

1. Bring the Microphone Amplifier in its "Off" position by means of the switch marked POWER on the front panel.
2. Connect the instrument to the power line and make sure that the line voltage selector placed on the rear of the instrument is in its proper position. If not, remove the fuse from the fuseholder and rotate the selector using a coin or similar means until the white mark indicates the desired value for the line voltage.
3. Reinsert the fuse and switch on the power. The scale light should come on immediately, and after a few minutes warm-up time the instrument is ready for use.
4. For calibration of the Microphone Amplifier the control knobs must be set in the following positions:
INPUT SWITCH: "Direct" or "Input Potentiometer"
METER RANGE: "Ref."
FREQUENCY RESPONSE SWITCH: "Linear 2—40000"
METER SWITCH: "RMS-fast"
RANGE MULTIPLIER: " $\times 1$ (0 dB)"
The control knobs not mentioned can be in any position.
5. The meter deflection should now be 16 dB (red mark on the scale). If not, adjust to the correct value by means of the screwdriver operated potentiometer SENSITIVITY-AMPLIFIER INPUT on the front panel.

Measuring.

The Microphone Amplifier has now been calibrated to be used as a linear vacuum tube voltmeter in the frequency range 2—40000 Hz and with an input impedance of 2.2 megohms in parallel with 30 pF.

1. The control knobs must be set in the following positions:
INPUT SWITCH: "Direct"
METER RANGE: "1000 V"
FREQUENCY RESPONSE SWITCH: "Linear 2—40000"
METER SWITCH: "RMS-fast" or any other of the 2×3 possible indicating positions.
RANGE MULTIPLIER: " $\times 1$ "
2. Feed the unknown voltage to the AMPLIFIER INPUT socket and turn the METER RANGE counter-clockwise (20 dB steps) until a suitable deflection is obtained on the meter.

If the deflection is insufficient even though the METER RANGE is in its "10 mV" position further increase in sensitivity will be necessary. This is accomplished by turning the RANGE MULTIPLIER counter-clockwise (10 dB steps). The total reading is then found by multiplying METER RANGE position and RANGE MULTIPLIER position, this value being full scale deflection referring to one of the two upper scales on the meter.

Example 1:

METER RANGE position: "10 V"

RANGE MULTIPLIER position: "× 1"

Full scale deflection is now found as $10 \text{ V} \times 1 = 10 \text{ volts}$, i.e. the 0—10 volts scale has to be used.

Example 2:

METER RANGE position: "10 mV"

RANGE MULTIPLIER position: "× 0.3"

Full scale deflection is now found as $10 \text{ mV} \times 0.3 = 3 \text{ mV}$, i.e. the 0—31.5 volts scale must be used.

The voltage measured can be recorded on a level recorder such as the Type 2305, which should then be connected to the output socket marked RECORDER. Other monitoring instruments such as oscilloscopes, tape recorders or even high impedance loudspeakers can be used utilizing the RECORDER socket which is able to give 10 volts r.m.s. for full deflection on the meter scale with an output impedance of 50Ω in series with $24 \mu\text{F}$.

SOUND LEVEL MEASUREMENTS

Setting up.

The Microphone Amplifier Type 2603 can operate as a precision sound level meter when used in conjunction with one of the B & K Condenser Microphones 4131, 4132, 4133 or 4134 and a cathode follower of the Type 2612, 2613, 2614

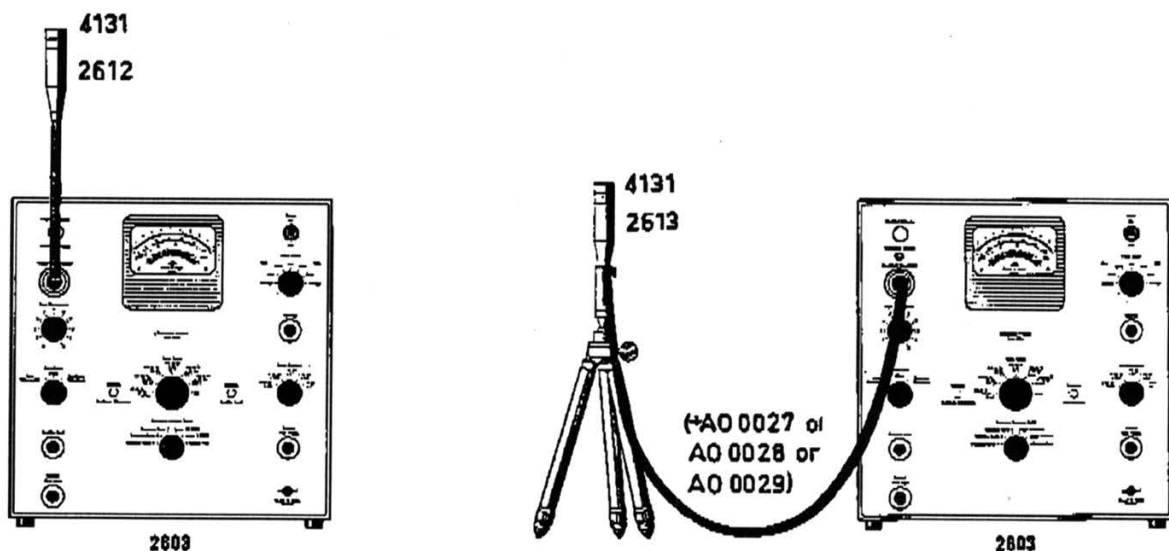

161112

Fig. 3.1. Various methods of connecting the Condenser Microphone to the Amplifier.

or 2615. An extension cable can be used, and it will normally be an advantage to place the Microphone on one of the Microphone Stands UA 0049. Further accessories for the microphones are outlined in their Instruction Books.

The Microphone is connected to the Amplifier by inserting the seven-pin plug into the socket marked CONDENSER MICROPHONE on the front panel, either going directly into the amplifier or using an extension cable (see Fig. 3.1.). Via the seven-pin plug the Microphone is supplied with the voltages necessary for its operation.

Calibration.

1. Insert the seven-pin plug from the Microphone into the CONDENSER MICROPHONE socket (Fig. 3.1).
2. Connect the Microphone Amplifier to the power line and make the same preparations as mentioned under "Voltage Measurements 1-3".
3. For calibration of the Microphone Amplifier + Condenser Microphone proceed as outlined in the following tables.

Microphone 4131 or 4132.

1. Check the microphone polarization voltage.
2. Set the control knobs in the following positions:—
INPUT SWITCH: "Condenser Microphone"
METER RANGE: "Ref."
METER SWITCH: "RMS-fast"
RANGE MULTIPLIER:
"× 1 (0 dB)"
FREQUENCY RESPONSE
SWITCH: "Linear 2—4000"
Control knobs not mentioned can be in any position.
3. Allow 2 minutes to warm up.
4. Next note the correction factor "K" from the calibration chart of the microphone employed (Fig. 3.2).
5. With a screwdriver turn the SENSITIVITY - CONDENSER MICROPHONE potentiometer until the meter pointer deflects to the red mark + the "K" factor in dB. If "K" factor is negative it has to be subtracted from the value which corresponds to the red mark.

Microphone 4133 or 4134.

1. Check the microphone polarization voltage.
2. Set the control knobs in the following positions:—
INPUT SWITCH: "Condenser Microphone"
METER RANGE: "Ref."
METER SWITCH: "RMS-fast"
RANGE MULTIPLIER:
"× 1 (0 dB)"
FREQUENCY RESPONSE
SWITCH: "Linear 2—4000"
Control knobs not mentioned can be in any position.
3. Allow 2 minutes to warm up.
4. Turn the SENSITIVITY - CONDENSER MICROPHONE potentiometer by means of a screwdriver until the meter pointer deflects to the red mark.

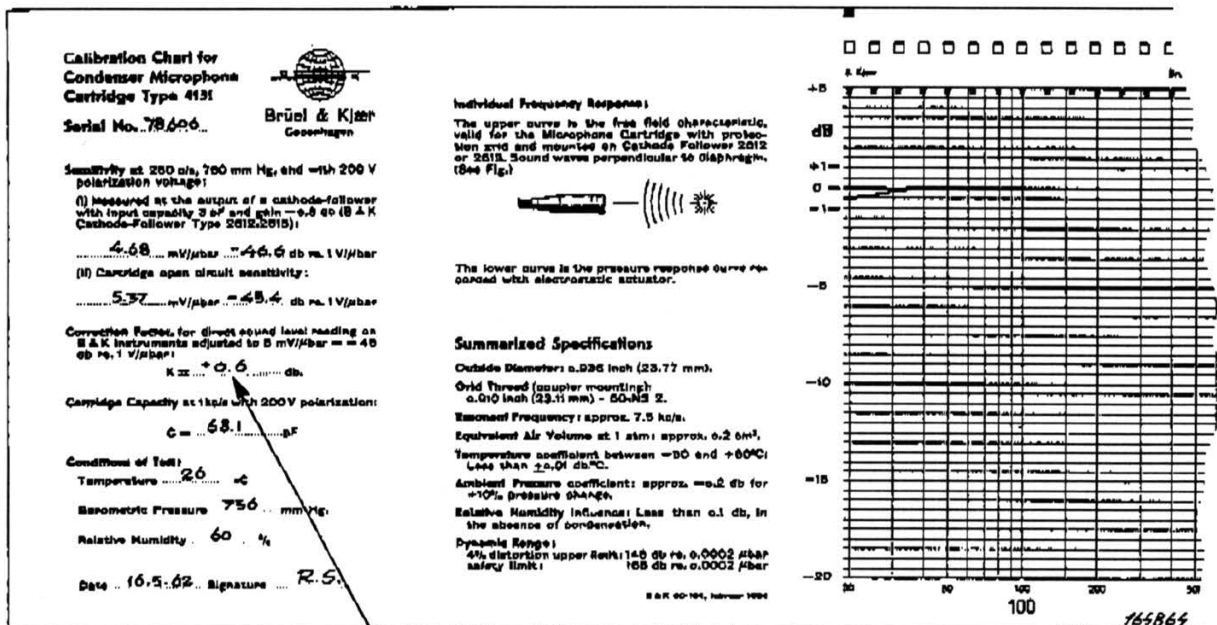

Correction Factor K

Fig. 3.2. Typical Microphone calibration curve with indication of the factor "K" in dB.

Measuring.

For sound level measurements the control knobs should be in the following positions:

- INPUT SWITCH: "Condenser Microphone"
- METER RANGE: "160 dB SL"
- FREQUENCY RESPONSE SWITCH: "Linear", "Weighting Curves A, B, and C" or "External Filter" as desired.
- RANGE MULTIPLIER: "0 dB"
- METER SWITCH: "RMS-fast" or other positions as desired.

The control knobs not mentioned can be in any position.

1. The Condenser Microphone should be exposed to the sound field.
2. METER RANGE switch is turned counter-clockwise until a suitable deflection is observed on the instrument meter. If a convenient deflection on the meter cannot be obtained by using METER RANGE switch, the RANGE MULTIPLIER switch may be set to a position with higher sensitivity.
3. The absolute value of the sound level can now be read on the instrument meter using the formulae:

Microphone 4131 or 4132.

The deflection in dB on the indicating meter

- + the number of dB SL indicated by METER RANGE
- + the number of dB indicated by RANGE MULTIPLIER

Microphone 4133 or 4134.

The deflection in dB on the indicating meter

- + the number of dB SL indicated by METER RANGE
- + the number of dB indicated by RANGE MULTIPLIER

+ the correction factor "K" in dB ("K" being the correction factor for the microphone).

Example 1:—

Deflection of the meter 19 dB
 Position of METER RANGE 60 dB SL
 Position of RANGE MULTIPLIER —10 dB
 Position of FREQUENCY RESPONSE SWITCH "B"
 Sound level = 19 dB + 60 dB — 10 dB
 = 69 dB (B)

Example 2:—

Deflection of the meter 10 dB
 Position of METER RANGE 80 dB SL
 Position of RANGE MULTIPLIER 0 dB
 Position of FREQUENCY RESPONSE SWITCH "B"
 Sound level = 10 dB + 80 dB + 0 dB
 = 90 dB (B)

Example 1:—

Deflection of the meter 15 dB
 Position of METER RANGE 100 dB SL
 Position of RANGE MULTIPLIER —10 dB
 Position of FREQUENCY RESPONSE SWITCH "C"
 Correction Factor "K" + 11 dB
 Sound level = 15 dB + 100 dB — 10 dB + 11 dB = 116 dB (C)

Example 2:—

Deflection of the meter 19 dB
 Position of METER RANGE 60 dB SL
 Position of RANGE MULTIPLIER 0 dB
 Position of FREQUENCY RESPONSE SWITCH "B"
 Correction Factor "K" 16 dB
 Sound level = 19 dB + 60 dB + 0 dB + 16 dB = 95 dB (B)

Recording of Sound Level.

In many workshops and offices the noise level will vary considerably with time and if the noise level was determined by means of a single reading it could give way to a serious error being introduced. Therefore, in such circumstances the noise level should be recorded over a relatively long period of time and the record studied, particularly with regard to the value and fre-

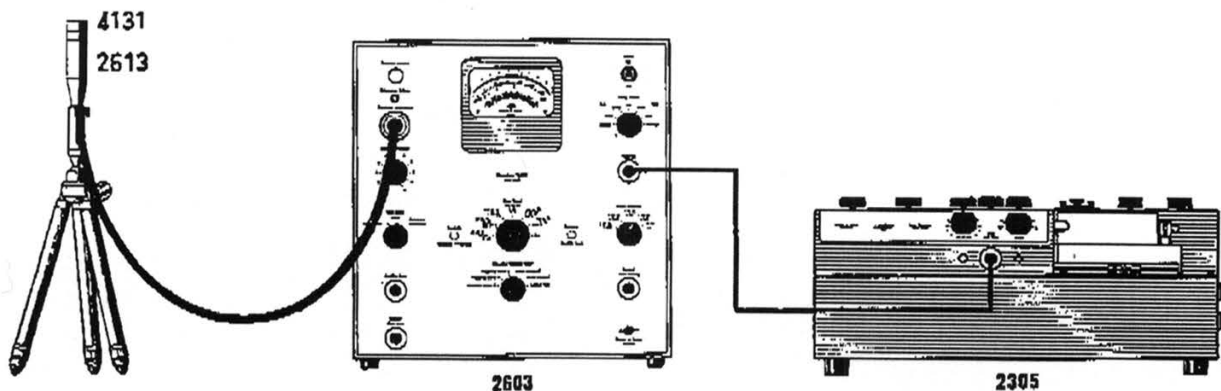

161111

Fig. 3.3. Measuring set-up for recording sound levels in relation to time.

quency of occurrence of noise peaks which are of the greatest interest in relation to health.

A suitable measuring arrangement is shown in Fig. 3.3 and consists of a B & K Condenser Microphone, the Microphone Amplifier Type 2603 and the Level Recorder Type 2305. The following calibration and operating procedure is recommended for this arrangement: Connect the RECORDER output of the Amplifier to the Level Recorder input and supply the Recorder with a 50 dB Range Potentiometer. (Refer Level Recorder Manual if necessary).

1. Measure the sound level referring to the preceding passage "Sound Level Measurements".
2. Next set the control knobs of the Level Recorder Type 2305 as follows:—

POTENTIOMETER RANGE DB:	"50"
RECTIFIER RESPONSE:	"RMS"
LOWER LIMITING FREQUENCY:	"20 Hz"
WRITING SPEED:	"100 (200)"
PAPER DRIVE STOP/START:	"Start"
PAPER DRIVE REVERSE/FORWARD:	"Forward"
POWER:	"On"
MOTOR:	"On"
3. Adjust INPUT POTENTIOMETER in conjunction with INPUT ATTENUATOR until sufficient stylus deflection is obtained, and select a suitable paper drive speed by means of the knob PAPER SPEED.
4. Start the recording by pressing the pushbutton SINGLE CHART — CONT. RECORDING and turning it clockwise to "Continuous Recording".

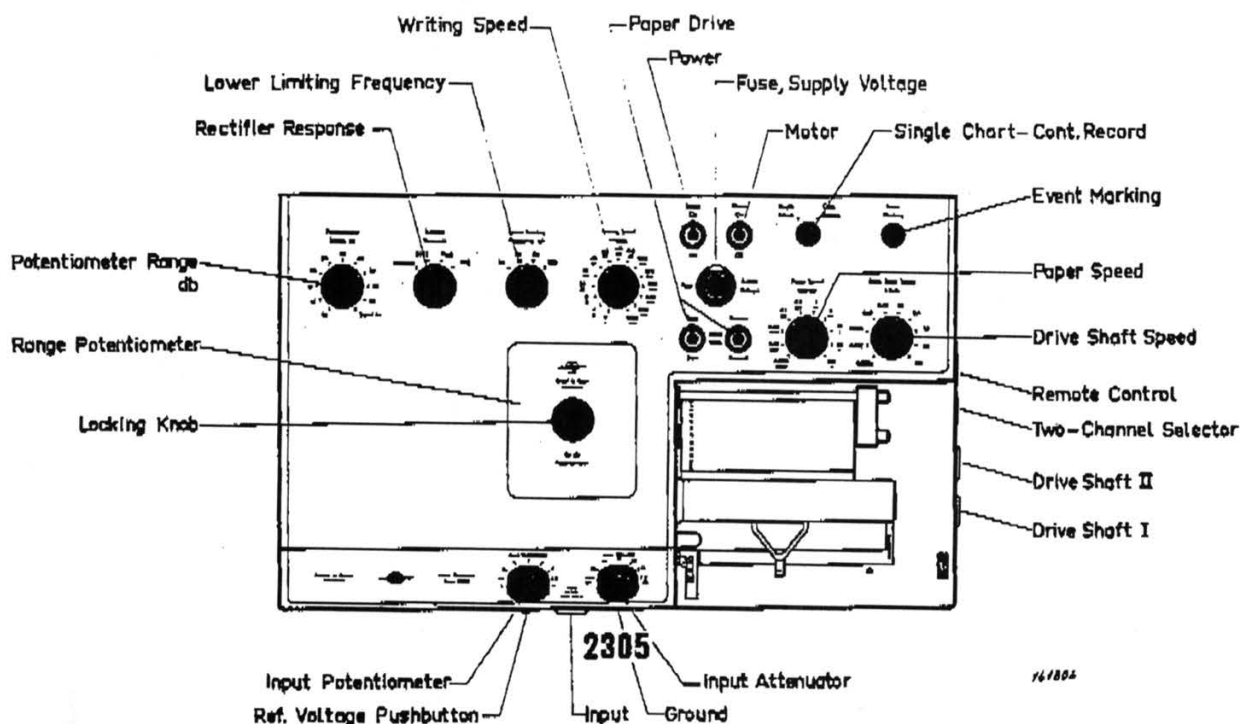

Fig. 3.4. Level Recorder Type 2305 with control knob identification.

5. After the desired period of recording has passed, the Level Recorder motor is stopped, by releasing the pushbutton SINGLE CHART. — CONT. RECORDING, and the paper cut-off. The variations in noise level can then be readily examined.

Remarks: For the necessary calibration of the recording paper use the sound level measured during adjustment. If this varies too quickly to obtain an accurate calibration figure for the measuring set-up it is recommended that use should be made of the *Pistonphone Type 4220* (or the Noise Source Type 4240) prior to commencement.

Calibration by means of the Pistonphone the Noise Source is carried out as described in the following passages.

Calibration by Means of a Calibrated Sound Source.

An easy way to calibrate or check a measuring arrangement for sound investigation is offered by the employment of the B & K Pistonphone Type 4220 or Noise Source Type 4240 respectively.

I. Pistonphone.

The Pistonphone is compact battery-operated, easily portable device, designed for the calibration of microphones and measuring set-ups. It is very accurate, and the calibration procedure actually consists of measuring the sound pressure level produced by this instrument.

1. The Microphone Amplifier control knobs should be positioned as follows:

Microphone 4131 or 4132.

INPUT SWITCH: "Condenser
Microphone"
METER RANGE: "120 dB SL"
RANGE MULTIPLIER:
"× 0.3 (−10 dB)"
FREQUENCY RESPONSE
SWITCH: "Linear 2—40000"
METER SWITCH: "RMS-fast"

Microphone 4133 or 4134.

INPUT SWITCH: "Condenser
Microphone"
METER RANGE: "100 dB SL"
RANGE MULTIPLIER: "× 1 (0 dB)"
FREQUENCY RESPONSE SWITCH:
"Linear 2—40000"
METER SWITCH: "RMS-fast"

2. Place the Pistonphone against the Microphone Cartridge and switch on its motor.
3. The indicating meter on the Microphone Amplifier should now deflect to:

Microphone 4131 or 4132.

The value of SPL given in dB on the calibration chart for the Pistonphone less 110 dB.

Microphone 4133 or 4134.

The value of SPL given in dB on the calibration chart for the Pistonphone, less 100 dB and in addition less "K".

"K" is the correction factor in dB valid for the Microphone in use.

Example:

The value of SPL given on the calibration chart 124.2 dB.
 The deflection of the indicating meter should then be:
 $124.2 \text{ dB} - 110 \text{ dB} = 14.2 \text{ dB}.$

Example:

The value of SPL given on the calibration chart: 124.2 dB.
 The correction factor "K" of the Microphone 13.3 dB.
 The deflection of the indicating meter should then be:
 $124.2 \text{ dB} - 100 \text{ dB} - 13.3 \text{ dB} = 10.9 \text{ dB}.$

4. Possible deviation has to be corrected by means of the SENSITIVITY-CONDENSER MICROPHONE accessible on the front of the Microphone Amplifier.
5. When the Level Recorder Type 2305 is combined with the Microphone Amplifier the deflection of its stylus can readily be calibrated by the Pistonphone. The procedure employed is the same as the one given here.

II. Noise Source.

The Noise Source is designed to give a quick check on measuring arrangements set up for sound investigation. The Source is a cartridge in which steel balls generate the noise level. Further information is given in the manual or data sheet for this device.

1. The procedure for employing the apparatus is similar to that given for the Pistonphone, with the exception that the control knobs of the Microphone Amplifier should now be set as follows:

Microphone 4131 or 4132.
 INPUT SWITCH: "Condenser Microphone"
 METER RANGE: "100 dB SL"
 RANGE MULTIPLIER:
 "× 0.3 (-10 dB)"
 FREQUENCY RESPONSE SWITCH: "Linear 2—40000"
 METER SWITCH: "RMS-fast"

Microphone 4133 or 4134.
 INPUT SWITCH: "Condenser Microphone"
 METER RANGE: "80 dB SL"
 RANGE MULTIPLIER:
 "× 1 (0 dB)"
 FREQUENCY RESPONSE SWITCH: "Linear 2—40000"
 METER SWITCH: "RMS-fast"

2. The Noise Source is placed against the Microphone Cartridge. The outer ring of the Noise Source housing should then be turned through 180° whereby the noise is generated by the running of the steel balls.
3. The indicating meter of Microphone Amplifier should now deflect to:

Microphone 4131 or 4132.
 The value of SPL written in dB on the Source housing less 90 dB.

Microphone 4133 or 4134.
 The value of SPL written in dB on the Source housing less 80 dB and further, less "K".
 "K" is the correction factor in dB valid for the Microphone in question.

Example:

Value of SPL given on the housing:
107 dB.

The indicating meter should then
deflect to:—
 $107 - 90 = 17$ dB

Example:

Value of SPL given on the housing:
107 dB.

The correction factor "K" of the Mi-
crophone: 13.3 dB.
The indicating meter should then de-
flect to:—
 $107 - 80 - 13.3 = 13.7$ dB

Influence of Background Noise.

If it is required to measure the sound emitted from a particular piece of equipment, e.g. an electric motor, best results would be obtained by removing the motor and do the measurements in an anechoic room with no disturbing background noise. However, this is not always possible, and the measurements have to be done with the background noise present.

If the background sound level with the motor switched off is much lower than the sound level with the motor running, no correction is required, but if the difference is less than about 10 dB it is necessary to correct for background noise. A graph is given below of the dB value to be subtracted from the total reading for different values of background sound level.

When the difference between total reading and background level is more than 2—3 dB this method is accurate enough for most purposes. However, when smaller differences are measured, the motor noise must be measured in an anechoic room, or the background sound level must be reduced.

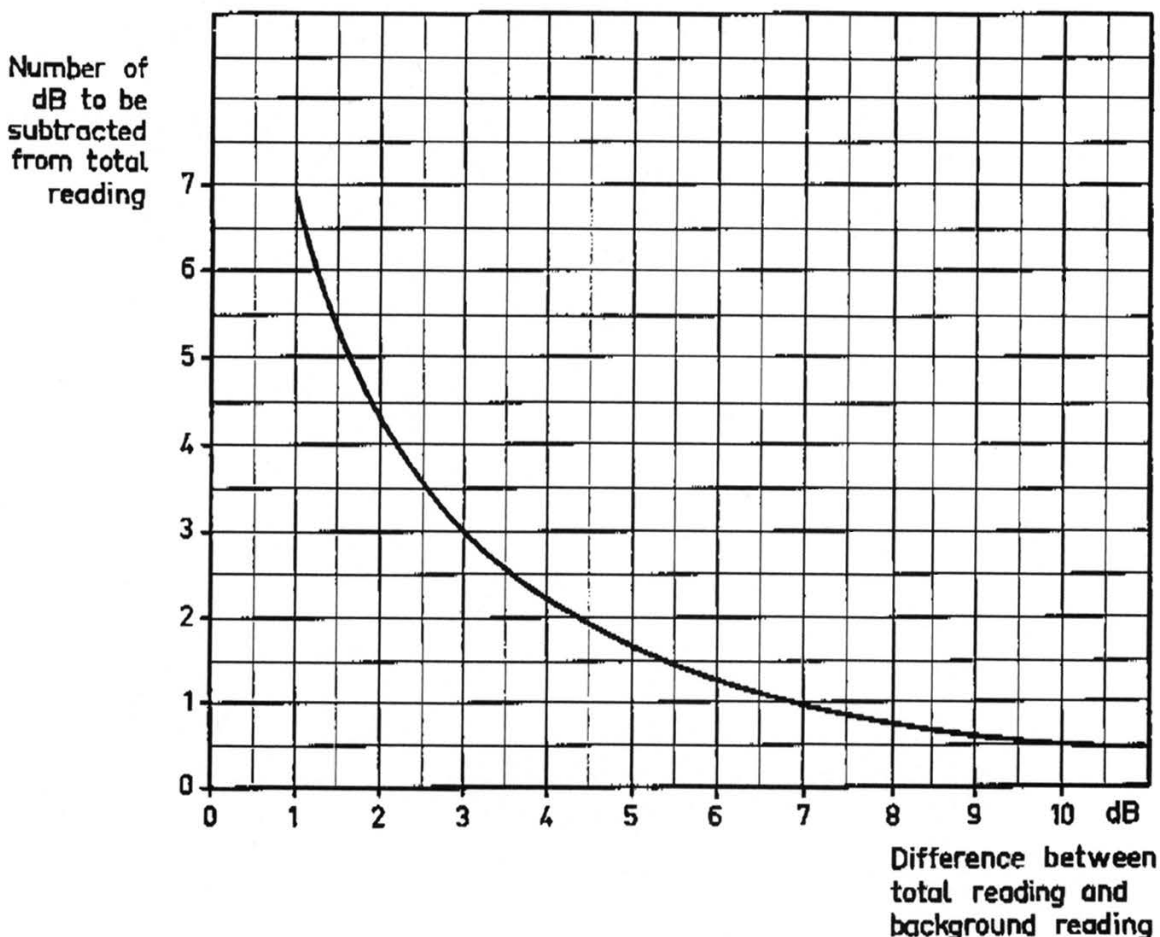

Consisting of:

Meter Circuit	2603.1
Output Amplifier	2603.2
Input Amplifier	2603.3
Weighting Network	2603.4
Position of Components	2603.5
Parts List	2603.6
Circuit Diagram	2603.7

Removal of the Metal Case

After removing the four threaded retainers at the back of the instrument, it is possible to slide the chassis and the front panel out of the case.

Trouble Shooting

If the reason for a fault is not an obvious one such as a dead tube, broken down resistor, blown or disconnected fuse etc., then first test the voltages of all the tubes and compare them with the voltages shown in the circuit diagram in order to localize the defect. Should this method of finding the fault prove unsuccessful, then check the instrument by adopting the method described in the adjustment procedure. When the trouble has been found and remedied, the voltages and adjustments which are influenced by the remedy must be rechecked.

The tolerances stated in the instructions can only be used as a guide for adjustment and control, but any deviations must not be corrected without being sure that the tolerances of the instruments used for making the adjustment are so small as to have no influence on the measurements.

The instructions in this Manual are given purely as a guide to the service of equipment. Some faults, as f.i. small deviations in tolerances require for their correction special control equipment and extensive experience, and in these cases it is necessary to send the instrument to the factory.

Instruments and accessories necessary for service and repair:

Multimeter (50 μ A)
Frequency Analyzer type 2107
Beat Frequency Oscillator type 1022
Pistonphone type 4220
Cathode Follower type 2612/2613
Condenser Microphone type 4131/32

1.1. Mechanical Zero-Point

METER SWITCH: "Off"
POWER: "Off."

Adjust for zero deflection.

1.2. Electrical Zero-Point

METER RANGE: "10 V"
RANGE MULT.: "X 1"
POWER: "On"

Check that the instrument is still at zero deflection.

Tolerance: "1/2 pointer width".

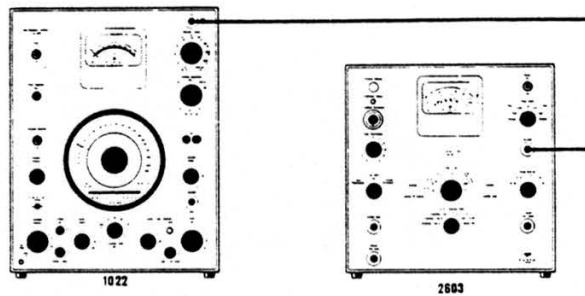

1.3. Check of Meter Switch

a. METER SWITCH: "RMS fast"
POWER: "Off."

Frequency: 1000 c/s. Adjust the input voltage for a 16 dB deflection on type 2603.

b. METER SWITCH to "Average fast"

Deflection on type 2603: 14.9-15.3 dB.
If necessary adjust P 6.

c. METER SWITCH to "Peak fast"

Deflection on type 2603: 18.5-19.5 dB.
If necessary adjust P 6 and repeat item b.

Also check a-b-c at 20 c/s in pos. "fast"
20.000 c/s " " "

1.4. Sensitivity

METER SWITCH: "RMS fast"
POWER: "Off"

Frequency: 1000 c/s. Adjust the input voltage for a full scale deflection on type 2603. The input voltage from type 1022 should be with 8-11 V.

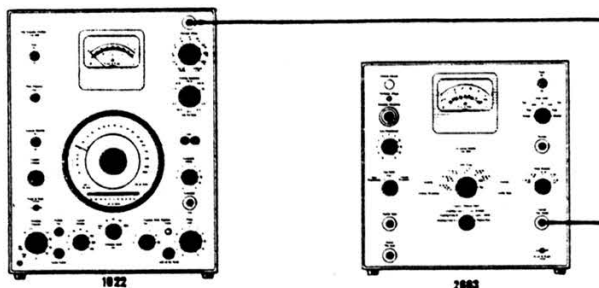

2.1. Sensitivity

- a. RANGE MULT.: "X 1"
METER SWITCH: "RMS"
INPUT SWITCH: "Direct"
FREQ. RESP. SWITCH: "Ext. filter"

Input signal: 1 V. 1000 c/s.
Deflection on type 2603: app. 10 V.
If not check item: 3.6.

2.2. Range Multiplier

- INPUT SWITCH: "Direct"
METER SWITCH: "RMS"
RANGE MULT.: "X 1"
FREQ. RESP. SWITCH: "Ext. filter"

Frequency: 1000 c/s. Adjust the input voltage for an 18 dB deflection on type 2603.

Check the steps of RANGE MULT. by comparison to type 1022.

Tolerance: ± 0.2 dB (+ tolerance of type 1022: 0.2 dB)

Possible reasons for fault: defective tube V 4
" capacitor C 2.

2.3. Frequency Response. Check

- a. INPUT SWITCH: "Direct"
METER SWITCH: "RMS"
RANGE MULT.: "X 1"
FREQ. RESP. SWITCH: "Ext. filter"

The apparatus must be placed in its case or in other way effectively screened.

Frequency: 1000 c/s. Adjust the input voltage for an 18 dB deflection on type 2603.

Vary the frequency from 20-20.000 c/s and check the deflection on type 2603.

Tolerance: ± 0.2 dB (+ tolerance of type 1022: 0.3 dB)

2.4. Frequency Response. Adjustment

- a. INPUT SWITCH: "Direct"
METER SWITCH: "RMS"
RANGE MULT.: "X 0.3"
FREQ. RESP. SWITCH: "Ext. filter"
- b. RANGE MULT. to X 0.1

Frequency: 1000 c/s. Adjust the input voltage for an 18 dB deflection on type 2603.

Change frequency to 20.000 c/s and adjust C 41 for an 18 dB deflection on type 2603.

as item a, but adjust C 43 for an 18 dB deflection on type 2603.

Possible reasons for fault: defective tubes V 4 - V 5 - V 16.

Whenever V 5 or V 16 is replaced, P 24 should be adjusted to V_k triode (pin 8, V 16) is 125 V d.c.

2.5. Output Impedance

- INPUT SWITCH: "Direct"
METER SWITCH: "Peak"
RANGE MULT.: "X 1"
FREQ. RESP. SWITCH: "Ext. filter"

Frequency: 1000 c/s. Adjust the input voltage for a 20 dB deflection on type 2603.

When loading the RECORDER socket with a resistor of 1200 Ω the deflection should be within 19.5 - 20 dB.

If necessary adjust P 24 or change V 16 and check d.c. voltage on V 16 pin 8: 110-140 V.

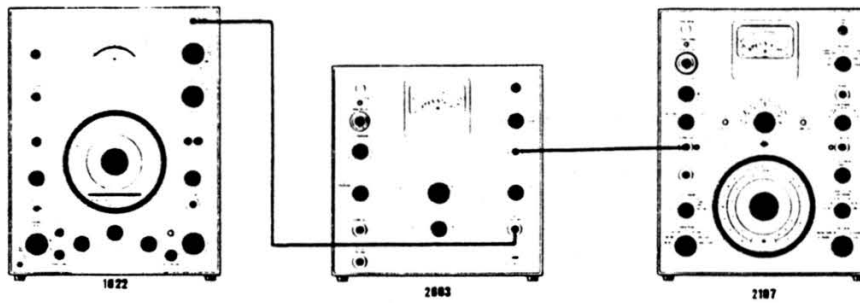

2.6. Output Voltage

- a. INPUT SWITCH: "Direct"
METER SWITCH: "RMS"
RANGE MULT.: "X 0.3"
FREQ. RESP. SWITCH: "Ext. filter"
- b. METER SWITCH to "Off"

Frequency: 1000c/s. Adjust the input voltage for a 20 dB deflection on type 2603.

Output voltage on the RECORDER socket: 8-11 V.

If the input voltage is increased by 10dB the output voltage should increase by 9.7 - 10.3 dB.

2.7. Noise - Hum.

- a. INPUT SWITCH: "Direct"
RANGE MULT.: "X 1"
FREQ. RESP. SWITCH: "Ext. filter"
METER SWITCH: "RMS"
- b. RANGE MULT. to "X 0.01"

The apparatus must be placed in its case or in other way effectively screened.

Disconnect type 1022 and measure hum at line frequency and 2nd and 3rd harmonic.

Tolerance: max. 5 mV hum
 max. 10 mV noise

Tolerance: max. 10 mV hum
 max. 20 mV noise

Possible reasons for fault: defective tube V4.

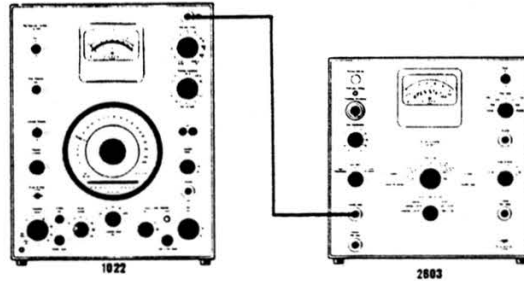

3.1. Meter Range

INPUT SWITCH: "Direct"
METER RANGE: "10 V"
FREQ. RESP. SWITCH: "Lin. 20-40.000 c/s"
RANGE MULT.: "X 1"
METER SWITCH: "RMS"

Frequency: 1000 c/s. Adjust the input voltage for an 18 dB deflection on type 2603.

Check the steps of METER RANGE by comparison to type 1022.

Tolerance: ± 0.2 dB (+ tolerance of type 1022: 0.2 dB)

Possible reasons for fault: defective tubes V 1 - V 2.

3.2. Frequency Response Check

INPUT SWITCH: "Direct"
METER RANGE: "10 V"
FREQ. RESP. SWITCH: "Lin. 2-40.000 c/s"
RANGE MULT.: "X 1"
METER SWITCH: "RMS"

Frequency: 1000 c/s. Adjust the input voltage for an 18 dB deflection on type 2603.

Vary the frequency from 20 - 20.000 c/s.

Deflection on type 2603: 18 dB.

Tolerance: ± 0.3 dB (+ tolerance of type 1022: 0.3 dB)

3.3. Frequency Response Adjustment.

a. INPUT SWITCH: "Direct"
METER RANGE: "100 mV"
FREQ. RESP. SWITCH: "Lin. 2-40.000 c/s"
RANGE MULT.: "X 1"
METER SWITCH: "RMS"

The apparatus must be placed in its case or in other way effectively screened.

Frequency: 1000 c/s. Adjust the input voltage for a 20 dB deflection on type 2603.

Change frequency to 20.000 c/s and adjust C 42 for a 20 dB deflection on type 2603.

b. METER RANGE to "10V"

As under item a but adjust C 40 for a 20 dB deflection on type 2603.

c. Check all steps of METER RANGE

Vary the frequency from 20-20.000 c/s.

Tolerance: ± 0.3 dB (+ tolerance of type 1022: 0.3 dB)

3.4. Overload Indicator

INPUT SWITCH: "Direct"
METER RANGE: "1 V"

Input signal: 1 V 1000 c/s.

The indicator should light up if the input voltage increases by 9 - 11 dB.

Also check at frequencies from 20 - 20.000 c/s.

3.5. Output Impedance

INPUT SWITCH: "Direct"
METER RANGE: "10 V"
FREQ. RESP. SWITCH: "Lin. 2-40.000 c/s"
RANGE MULT.: "X 0.1"
METER SWITCH: "RMS"

Load the EXT. FILTER INPUT socket with a resistor of 500 Ω in series with a 50 μ F capacitor.

Set frequency to 1000 c/s and adjust the input voltage for a 20 dB deflection on type 2603.

When changing the resistor to 50 Ω the deflection on type 2603 should be within 19-20 dB.

3.6. Reference

- a. INPUT SWITCH: "Direct"
METER RANGE: "10 V"
RANGE MULT.: "X 1"
METER SWITCH: "RMS"
FREQ. RESP. SWITCH: "Lin. 2-40.000 c/s"
- b. METER RANGE to "Ref."
- c. INPUT SWITCH to "Cond. micr."

Frequency: 1000 c/s. Adjust the input voltage to exactly 10 V.
Adjust P 3 SEN. AMPL. INPUT for full scale deflection on type 2603.

Adjust P 1 for deflection to the red line on type 2603.

Adjust P 2 SEN. COND. MICR. for deflection to the red line on type 2603.

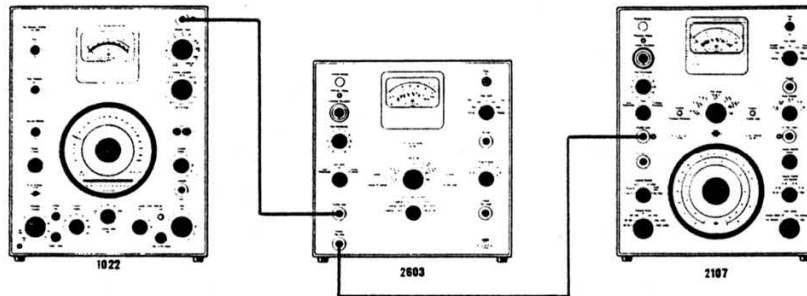

3.7. Distortion

- INPUT SWITCH: "Direct"
METER RANGE: "10 V"
FREQ. RESP. SWITCH: "Ext. filter"

Distortion down to around 0.5% can be measured by type 1022 and type 2107 only. Lower distortion requires the use of a filter type 1607 connected between type 2603 and type 2107 for rejection of fundamental frequency and a filter connected between type 1022 and type 2603 to ensure that the distortion of the input signal is below 0.01%.

If these filters are available check limits.

Adjust the input voltage for 1 V on EXT. FILTER INPUT socket which is loaded with a resistor of 500 Ω in series with a 50 μF capacitor.

Measure distortion at 40 - 1000 - 6500 c/s.

Tolerance:	max. 0.1%	2nd harmonic
	max. 0.1%	3rd harmonic

3.8. Noise - Hum

- a. INPUT SWITCH: "Potentiometer"
METER RANGE: "10 mV"
FREQ. RESP. SWITCH: "Ext. filter"
INPUT POTENTIOMETER: 10
- b. INPUT POTENTIOMETER: 0

The apparatus must be placed in its case or in other way effectively screened. Disconnect type 1022 and measure hum at line frequency and 2nd and 3rd harmonic.

Tolerance:	max. 200 μV hum
	max. 1.5 mV noise

Tolerance:	max. 200 μV hum
	max. 500 μV noise

Possible reasons for fault: defective tube V 1
" resistor R 31.

3.9. Polarization Voltage

Connect a multimeter to POL. VOLTAGE socket and check the d.c. voltage: 200 V.

If necessary adjust P 4.

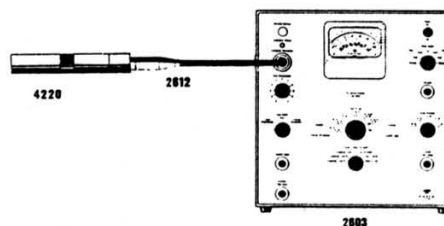

3.10. Acoustical Calibration

- INPUT SWITCH: "Cond. micr."
METER RANGE: "120 dB SL"
FREQ. RESP. SWITCH: "Lin. 20-40.000 c/s"
RANGE MULT.: "-10 dB"
METER SWITCH: "RMS fast"

Switch on the pistonphone and adjust P 2 SEN. COND. MICR. until the deflection on type 2603 is equal to the SPL produced by the pistonphone, with, for example, a pistonphone producing 124.1 dB the deflection should be 14.1 dB.

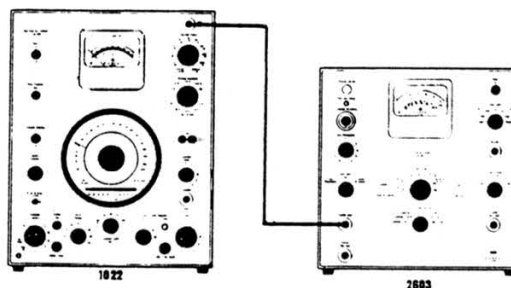

4.1. Linear

METER SWITCH: "RMS"
INPUT SWITCH: "Direct"
RANGE MULT.: "X 1"
FREQ. RESP. SWITCH: "Lin. 2-40.000 c/s"
METER RANGE: "10 V"

Frequency: 1000 c/s. Adjust the input voltage for an 18 dB deflection on type 2603.

Change frequency to 50 c/s.
Deflection on type 2603: 18 dB.
Tolerance: ± 0.1 dB (+ tolerance of type 1022: 0.3 dB)
If necessary adjust R 99.

Vary the frequency from 20 - 20.000 c/s.
Deflection on type 2603: 18 dB.
Tolerance: ± 0.3 dB (+ tolerance of type 1022: 0.3 dB)

4.2. Curve A-B-C. Check.

a. METER SWITCH: "RMS"
INPUT SWITCH: "Direct"
RANGE MULT.: "X 1"
FREQ. RESP. SWITCH: "Lin. 2-40.000 c/s"
METER RANGE: "10 V"

Frequency: 1000 c/s. Adjust the input voltage for an 18 dB deflection on type 2603.

Freq. c/s	Curve "A"		Curve "B"		Curve "C"	
	Defl. on type 2603 dB	Range Mult.	Defl. on type 2603 dB	Range Mult.	Defl. on type 2603 dB	Range Mult.
20	4.6-12.6	X 0.01	10.6-18.6	X 0.1	8.7-16.7	X 1
63	10.4-13.9	X 0.1	7.1-10.6	X 1	15.7-19.2	X 1
500	14.4-15.2	X 1	17.3-18.1	X 1	17.6-18.4	X 1
1000	17.7-18.3	X 1	17.7-18.3	X 1	17.7-18.3	X 1
2000	19.0-19.4	X 1	17.6-18.0	X 1	17.6-18.0	X 1
8000	15.7-17.4	X 1	13.8-15.5	X 1	13.8-15.5	X 1
20.000	6.8-10.3	X 1	15.0-18.5	X 0.3	14.9-18.4	X 0.3

4.3. Curve A-B-C. Adjustment at 1 kc/s.

a. METER SWITCH: "RMS"
INPUT SWITCH: "Direct"
RANGE MULT.: "X 1"
FREQ. RESP. SWITCH: "Lin. 2-40.000 c/s"
METER RANGE: "10 V"

Frequency: 1000 c/s. Adjust the input voltage for an 18 dB deflection on type 2603.

b. FREQ. RESP. SWITCH to curve "A"

Adjust R 98 for an 18 dB deflection on type 2603.

c. FREQ. RESP. SWITCH to curve "B"

Adjust R 97 for an 18 dB deflection on type 2603.

d. FREQ. RESP. SWITCH to curve "C"

Adjust R 94 for an 18 dB deflection on type 2603.

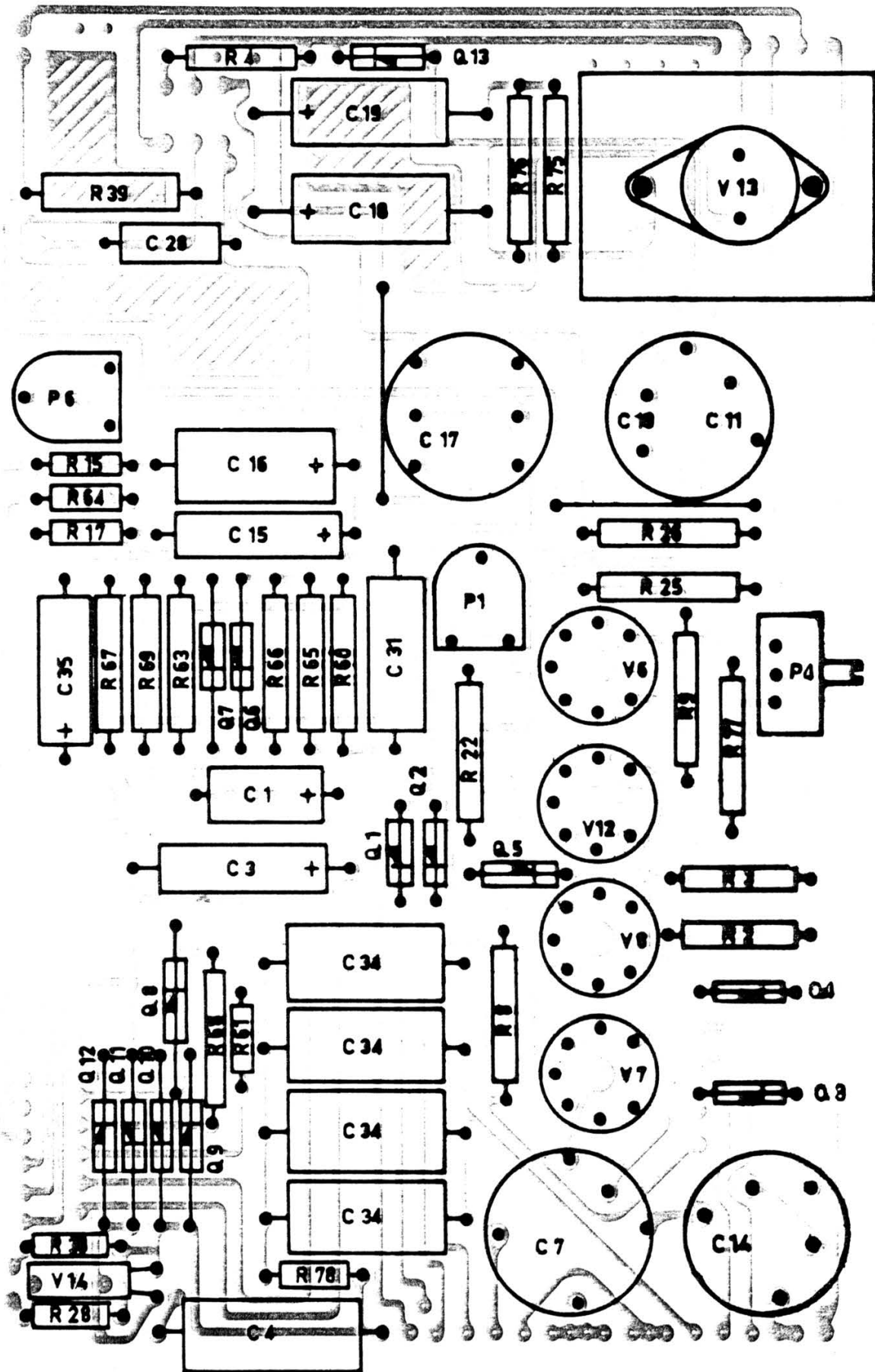

Power Supply

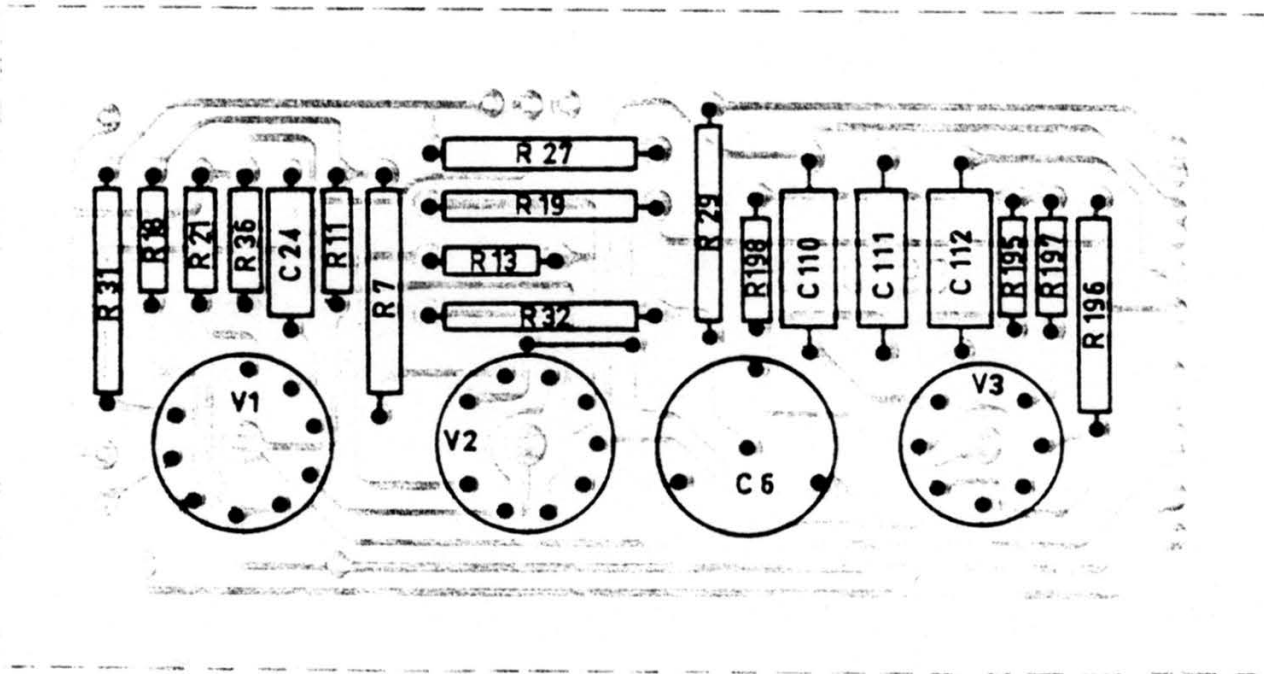

Input Amplifier

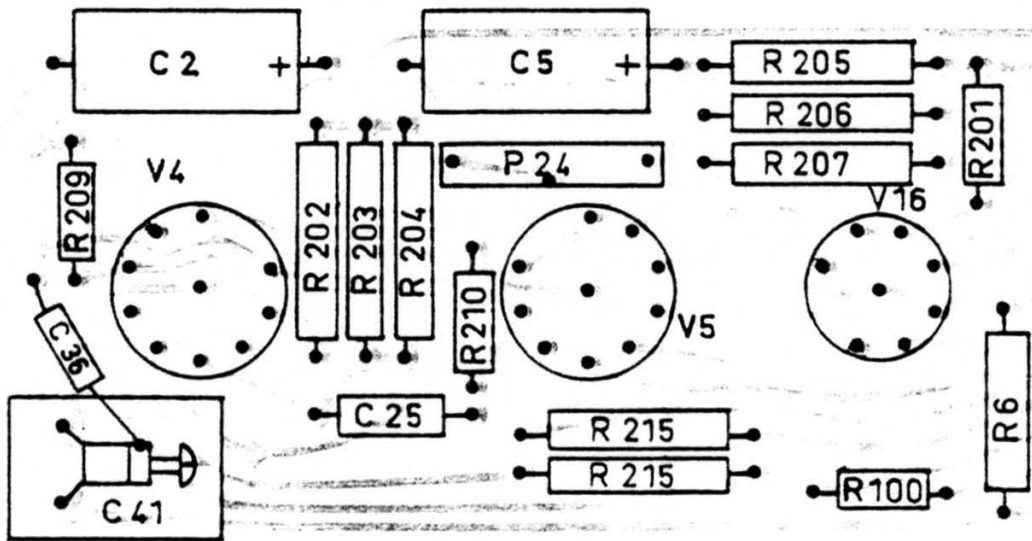

Output Amplifier

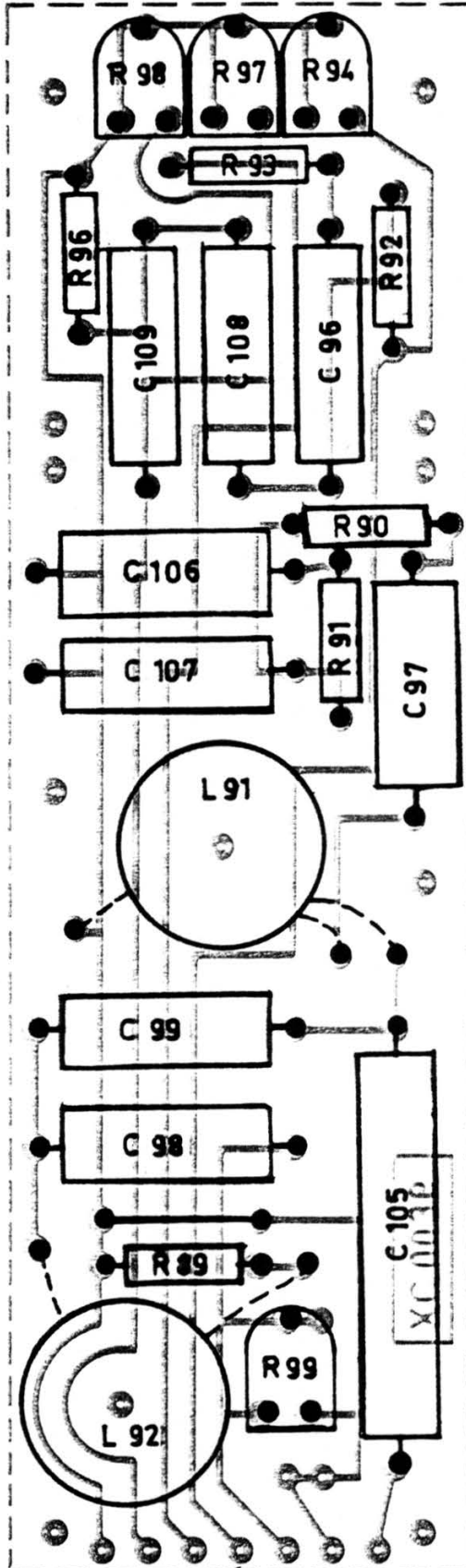

Weighting Network

CIRCUIT DIAGRAM REF.	COMPONENT TYPE		STOCK REF.	CIRCUIT DIAGRAM REF.	COMPONENT TYPE		STOCK REF.
CAPACITORS:				R 39	Carbon	1/2 W 10%	25 MΩ
C 1	Electrolytic	4 μF/250 V	CE 2034	R 41	"	" 0,5%	22,2 Ω
C 2	"	8 μF/350 V	CE 0802	R 42	"	"	200 Ω
C 3	"	50 μF/ 64 V	CE 0513	R 43	"	"	2 kΩ
C 4	" rev.	24 μF/ 25 V	CE 0412	R 44	"	"	20 kΩ
C 5	"	8 μF/350 V	CE 0802	R 45	"	"	200 kΩ
C 6	"	16 μF/450 V	CE 6846	R 46	"	"	2 MΩ
C 7	"	50 μF/450 V	CE 0907	R 47	"	"	14,6 kΩ
C 8,9	"	2 x 100 μF/350 V	CE 0804	R 48	"	"	31,5 kΩ
C 10,11	"	2 x 100 μF/250 V	CE 0707	R 49	"	"	100 kΩ
C 12,13	"	2 x 100 μF/350 V	CE 0804	R 50	"	"	315 kΩ
C 14	"	150 μF/350 V	CE 0803	R 51	"	"	1 MΩ
C 15	"	125 μF/ 16 V	CE 0312	R 60	"	"	2,66 kΩ
C 16	"	640 μF/ 16 V	CE 0209	R 61	"	1/3 W 10%	7 kΩ
C 17	"	2000 μF/ 25 V	CE 0411	R 63	"	1/2 W 0,5%	8,9 kΩ
C 18,19	"	250 μF/ 25 V	CE 0413	R 64	"	1/3 W 10%	6,3 kΩ
C 21	Ceramic	1 pF/500 V	CK 0100	R 65	"	1/2 W 0,5%	17,6 kΩ
C 22	Polystyrene	250 pF/500 V	CT 0108	R 66	"	"	19,7 kΩ
C 23	"	125 pF/500 V	CT 0104	R 67	"	"	23,7 kΩ
C 24	Polyester	22 nF/400 V	CS 0105	R 68	"	"	34,3 kΩ
C 25	"	0,1 μF/250 V	CS 0013	R 69	"	"	49 kΩ
C 26	"	56 nF/400 V	CS 0110	R 70	"	" 10%	10 MΩ
C 27	Ceramic	4,7 nF/500 V	CK 3470	R 75,76	"	"	100 Ω
C 28	Polyester	0,22 μF/250 V	CS 0017	R 90,91	"	1/3 W 2%	3,15 kΩ
C 29,30	Paper	0,25 μF/400 V	CP 1722	R 92	"	"	14 kΩ
C 31	Polyester	1 μF/250 V	CS 0025	R 93	"	"	32 kΩ
C 32	Ceramic	1 pF/500 V	CK 0100	R 96	"	"	160 kΩ
C 33	Polyester	68 nF/250 V	CS 0011	R 195	"	" 10%	5 MΩ
C 34	"	2 μF/250 V	CS 0028	R 196	"	1/2 W "	50 kΩ
C 35	Electrolytic	16 μF/ 63 V	CE 0504	R 197	"	1/3 W 5%	800 Ω
C 36	Ceramic	4,7 pF/500 V	CK 0470	R 198	"	"	500 Ω
C 40	Trimmer	3 pF	CV 0113	R 200	"	1/3 W 10%	31,5 kΩ
C 41	"		CV 0013	R 202	"	1/2 W 5%	1,25 MΩ
C 42,43	"	6 pF	CV 0112	R 203,204	"	"	630 kΩ
C 96	Polystyrol 2%	6,3 nF/200 V	CT 3346	R 205-207	"	" 10%	160 kΩ
C 97,98	" "	63 nF/100 V	CT 3130	R 209	"	" 5%	2 kΩ
C 99	Electrolytic rev.	2 μF/100 V	CE 8927	R 210	"	1/3 W 10%	315 kΩ
C 105	"	40 μF/170 V	CE 2038	R 211	"	"	50 Ω
C 106	Polystyrol 2%	3,15 nF/200 V	CT 3127	R 212	"	"	10 MΩ
C 107-109	"	4 nF/200 V	CT 3325	R 215	"	1/2 W 5%	125 Ω
C 110-112	Polyester	0,1 μF/250 V	CS 0113	POTENTIOMETERS:			
RESISTORS:				P 1	Ref. Voltage Adj.		50 kΩ PG 3501
R-2	Wire	5,5 W	10%	330 Ω	RX 0300		
R 3	"	"	"	3,3 kΩ	RX 0306		
R 4	"	"	"	30 Ω	RX 0309		
R 6	"	8 W	"	6,8 kΩ	RX 0401		
R 7	"	5,5 W	"	6,2 kΩ	RX 0303		
R 8	Carbon	1 W	"	100 kΩ			
R 9	"	"	"	6,3 kΩ			
R 11	"	1/3 W	5%	56 Ω			
R 12	"	1/2 W	10%	200 Ω			
R 13	"	1/3 W	"	50 Ω			
R 14	"	"	"	800 kΩ			
R 15	"	"	"	160 Ω			
R 17	"	"	5%	200 Ω			
R 18	"	"	10%	1 kΩ			
R 19	"	1/2 W	"	1,25 kΩ			
R 21	"	1/3 W	"	2,5 kΩ			
R 22	"	1/2 W	5%	86 kΩ			
R 25,26	"	"	10%	31,5 kΩ			
R 27	"	"	"	50 kΩ			
R 28	"	1/3 W	5%	25 kΩ			
R 29	"	1/2 W	10%	100 kΩ			
R 31	"	"	"	315 kΩ			
R 32	"	"	5%	315 kΩ			
R 36	"	1/3 W	10%	3,15 MΩ			
R 38	"	"	5%	125 kΩ			
P 2				100 Ω	PQ 1100		
P 3				100 Ω	PQ 1100		
P 4				50 kΩ	PB 3501		
P 5				1 MΩ	PP 5100		
P 6				5 kΩ	PG 2500		
P 24				1 kΩ	PG 2103		
R 94				150 kΩ	PG 4151		
R 97-99				300 kΩ	PG 4301		
SWITCHES:				N	Power On-Off		NN 0563
O 1				Input Switch	OR 2603		
O 2				Meter Range	OV 2110		
O 3				Weighting Network	OT 2603		
O 4				Range Multiplier	OT 2109		
O 5				Meter Switch	OS 2112		
O 6				Power Voltage Selector	OA 0021		
RECTIFIERS:				Q 3,4	Silicon	1200 V/0,15 A	QV 0025
Q 5				Zener	6,8 V/ 30mA		QV 1106
Q 6				Germanium	115 V/0,15 A		QV 0085
Q 7				"	45 V/ 0,1 A		QV 0078
Q 8-12				"	115 V/0,15 A		QV 0085
Q 13				Zener	13 V/ 15mA		QV 1316
Q 14,15				Silicon	50 V/ 0,6 A		QV 0501

CIRCUIT DIAGRAM REF.	COMPONENT TYPE	STOCK REF.	CIRCUIT DIAGRAM REF.	COMPONENT TYPE	STOCK REF.
----------------------------	-------------------	---------------	----------------------------	-------------------	---------------

TUBES-TRANSISTORS:

V 1	Twin-triode	ECC83/12AX	VA 0012
V 2	"	ECC81/12AT7	VA 0009
V 3	Pentode	EF94/6AU6	VA 0021
V 4	"	EF86/6CF8	VA 0019
V 5	"	EF184/6EJ7	VA 0079
V 6	Stabilizer	OB2	VA 0040
V 7	"	OA2	VA 0037
V 8	"	OB2	VA 0040
V 9	Fuse	1 A	VF 0008
V 10	Dial Lamp	6.3 V/0.5 A	VS 1271
V 11	Neon Lamp	110 V	VS 8001
V 12	Stabilizer	OB2	VA 0040
V 13	Germanium Trans.	2N554	VB 0023
V 14	Cold Cathode Tube	3L/90 V	VA 0072
V 16	Pentode	EL95/6DL5	VA 0026

PRINTED CIRCUITS:

	Weighting Network	XC 0036
	Input Amplifier	XC 0252
	Power Supply	XC 0256
	Output Amplifier	XC 0422
	XC 0036 with components	8480063
	XC 0252 "	8012603
	XC 0256 "	8002603
	XC 0422 "	8022603

MISCELLANEOUS:

	Bakelite Knob, large	SN 4021
	" , small	SN 3222
	Knob Retaining Ring	DB 0674
	Screw for do	YQ 2083
	Cabinet	KA 0011
L 91	L 91 Filter Coil	LB 0017
L 92	"	LB 0431
	Cover, plastic	KF 0027
	Jack, coaxial	JJ 0013
	" , ground	JT 6204
	" , insulates	JT 8344
	" , microphone	JJ 0016
I	Moving Coil Meter	IM 2604
	Phonefilter	ZS 0017
	Plug, coaxial	JP 0018
	Power Cord EUR	AN 0005
	" USA	AN 0006
T	Power Transformer	TN 0001

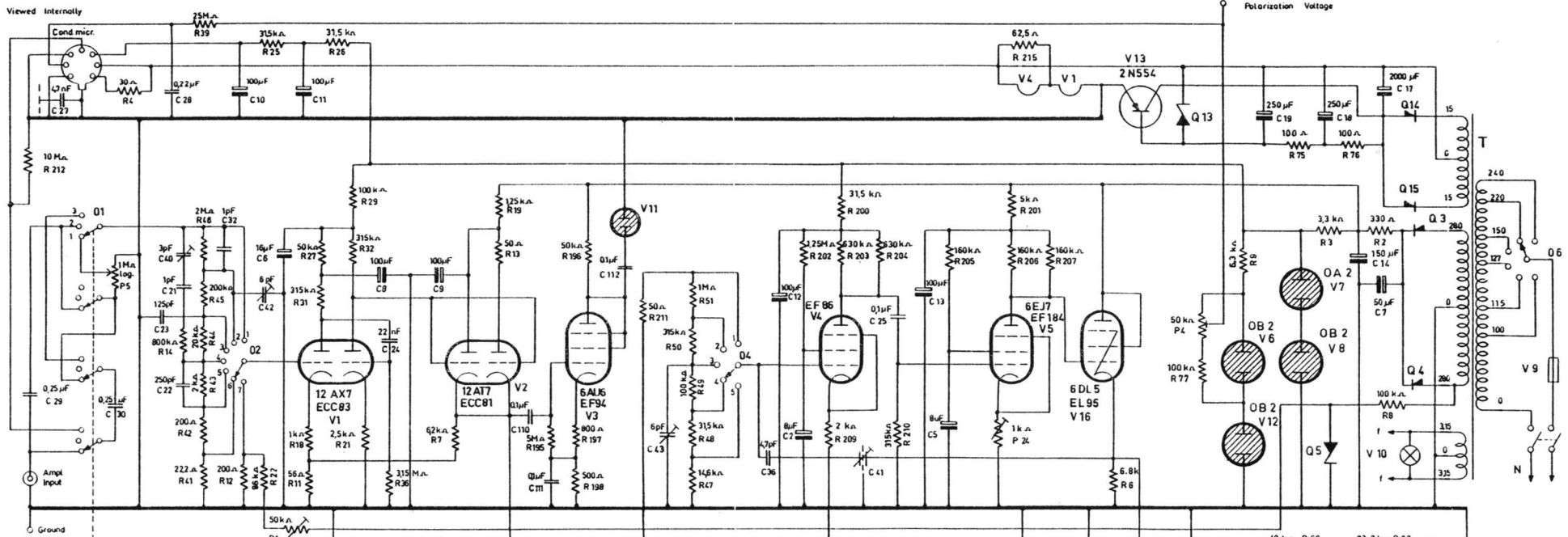

- P1: Ref voltage adj.
P2: Sensitivity condenser micr.
P3: Sensitivity amp input
P4: Polarization voltage adj.
P5: Input potentiometer
- O1: Input Switch
1 Potentiometer
2 Direkt
3 Condenser Microphone
- O2: Meter Range
1 10mV
2 100mV
3 1V
4 10V
5 100V
6 1000V
7 Ref.

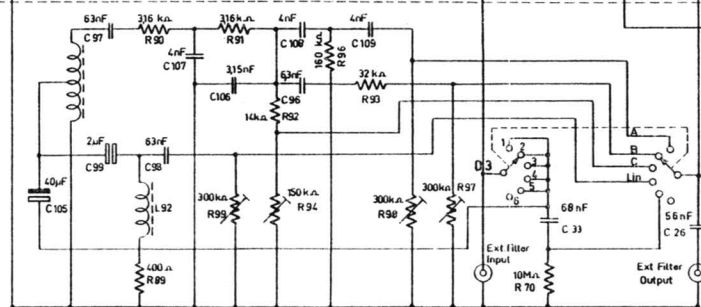

- O3: Frequency Response Switch
1: Weighting Curve A
2: - " - B
3: - " - C
4: Linear 20-40000
5: 2-40000
6: External Filter

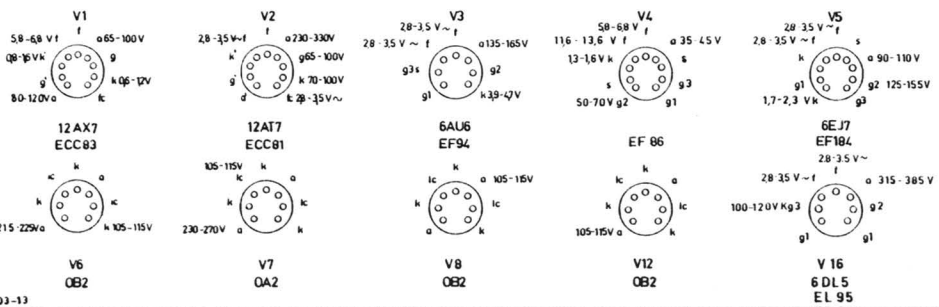

- O4: Range Multiplier
1: - 0.01
2: - 0.03
3: - 0.1
4: - 0.3
5: - 1
- O5: Meter Switch
1: Average Fast
2: Peak -
3: RMS -
4: Off
5: RMS Slow
6: Peak -
7: Average -

17-11-66	192197		
8-11-67	204180		
20-3-68	228097		



Here are some photos once again taken from e-bone. The seller's name was batessurplus. I'm not sure who actually took the shots. These photos are of a B&K 2604.





