

# Altec Precision Attenuators and Networks

ATTENUATORS  
AND  
NETWORKS

Bridging Pads



VU Extenders



Rotary Attenuators

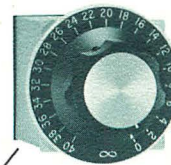

Typical 9200 Series  
Altec Console Utilizing  
Components from this Catalog

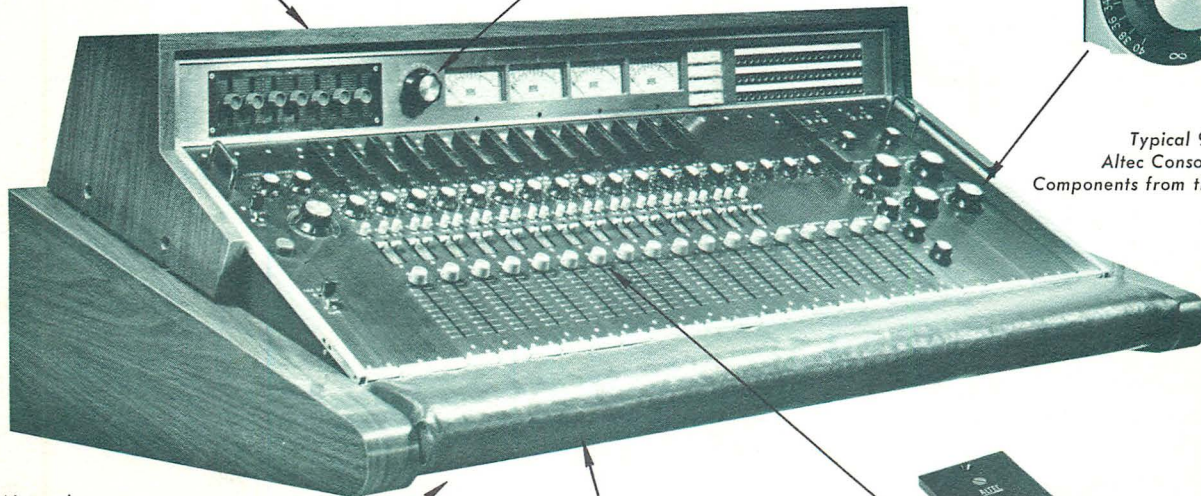

Mixing Networks

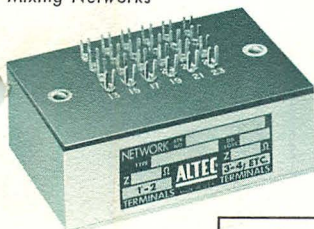

Loss Pads



Straight Line  
Attenuators

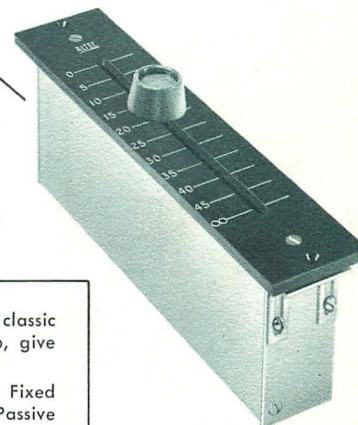

ALTEC precision Attenuators and Networks are engineered in accordance with classic design techniques. The finest materials, combined with experienced craftsmanship, give extreme reliability.

ALTEC Attenuators and Networks are made in three basic classifications: (1) Fixed (2) Rotary (3) Straight Line. This catalog lists 14 different categories. Every "Passive Loss" device required in the construction of professional speech input equipment is now available from a single source.

## TABLE OF CONTENTS

	Page		Page		Page
General Information .....	2	Calibrated Grid Control Potentiometers: RP8600-8606, RP8621-8627, RP8640-8643 Series .....	6	Rotary Differential Attenuators: RA8811 Series .....	8
Ordering Information .....	3	Precision Decade Attenuators: DA8735-8746 Series .....	7	VU Meter Range Extenders: VU8010-8011, VU8700-8712 Series .....	9
Impedance Code .....	3	Precision Variable Impedance Matching Networks: PN8747-8754 Series .....	7	Mixer Networks: MN8000 Series .....	10
Straight Line Attenuators (Primarily used in Mixing Circuits): SM8272-8281 and SM8324-8327 Series .....	4	Motion Picture Projection and Turntable Faders: FA8800-8801, FA8804-8805 Series ....	8	Fixed Loss Pads: LP8000 Series .....	11
Rotary Attenuators (Primarily used in Mixing Circuits): RM8200-8223 and RM8225-8226 Series .....	5	Stereo Pan Potentiometers: PP8806-8807-8812 Series .....	8	Bridging Pads: BP8000 Series .....	11
Calibrated Attenuators: RA8400-8418, RA8457-8474, RA8505-8506 Series .....	6			Minimum Loss Matching Pads: MP8000 Series..	11
				VU Meter corrections for impedances other than 600Ω. A chart for rapid conversion of Indicated-VU to actual dBm .....	12



A Division of *LSV* Ling Altec, Inc.

1515 S. Manchester Ave., Anaheim, Calif. 92803  
New York

RECORDING &

BROADCASTING

EQUIPMENT

**GENERAL:**

The basic information on this page is intended as a guide to practices relative to passive resistive networks that have been accepted by a majority of engineers engaged in audio systems-design.

**WHAT IS A MIXER?** Specifically, a mixer is a passive, fixed network composed of non-inductive resistances (see Page 10). In normal practice, each input leg of these networks has a variable attenuator associated with it. Such variable attenuators are called "Mixer Controls." Mixer Controls are standard, variable attenuators that meet the following requirements:

1. No detents are used, and the dial markings have arbitrary scale markings.
2. Attenuation is linear down to about 45 dB, and then rapidly tapers off in increasingly larger steps to maximum cutoff.
3. Circuit configuration is compatible with low-noise requirements and impedance-match to the fixed-mixer network.

In control consoles used for mixing audio signals, two circuit configurations predominate for use in variable attenuators. These are the "ladder" and the "bridged-T." For the mixer control application, the ladder is usually preferred, since it allows a maximum attenuation of -120 dB, as compared to the "T's" -90 to -100 dB. Additionally, contact noise and signal level both decrease with increasing attenuation in the ladder, whereas contact noise remains at the same level as the signal is attenuated in the "T." Another "built-in" advantage of the ladder circuit, when used as a mixer control, is the 6-dB insertion loss provided. This residual loss ensures impedance isolation between the mixer network and the output

of the preamplifier. Due to modern negative feedback design practices, the preamplifier often presents a very low output impedance to the mixer network if no isolation is provided. The bridged-T makes an excellent board master - at this point in the console, signal levels are sufficiently high, and noise control is less of a problem.

**CIRCUIT TYPES**

Attenuators are available in both unbalanced and balanced circuit configurations. Professional audio consoles normally use unbalanced attenuators, even though all input and output lines are balanced. This is due to:

1. An unbalanced circuit allows simplicity of design (one-half the components required for balanced configuration.)
2. Associated equipments, such as equalizers, are normally available only as unbalanced circuits.
3. Cost of a console more than doubles, if balanced circuitry is employed.

Balanced circuitry, however, is the rule for any line outside the physical confines of the console itself. Balanced attenuators are employed where they must be inserted in long audio lines or where an unbalance-to-ground would cause difficulty - as in measurement work.

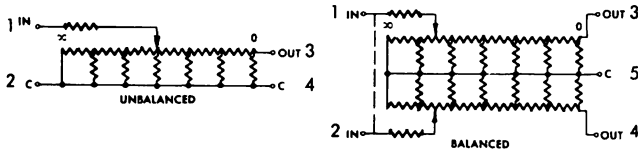

Ladder Circuits

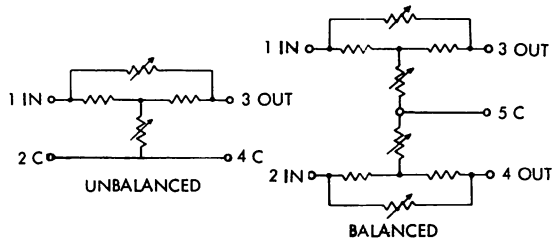

Bridged-T and Balanced-H Circuits

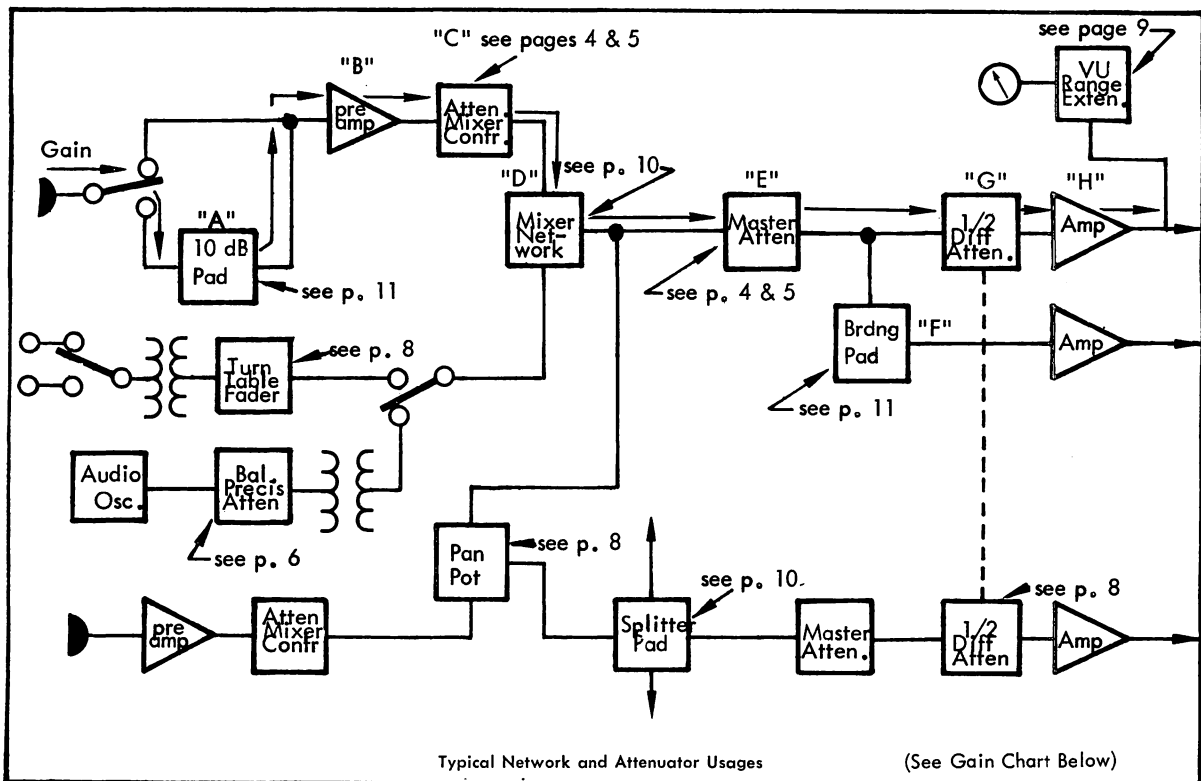

Typical Network and Attenuator Usages

(See Gain Chart Below)

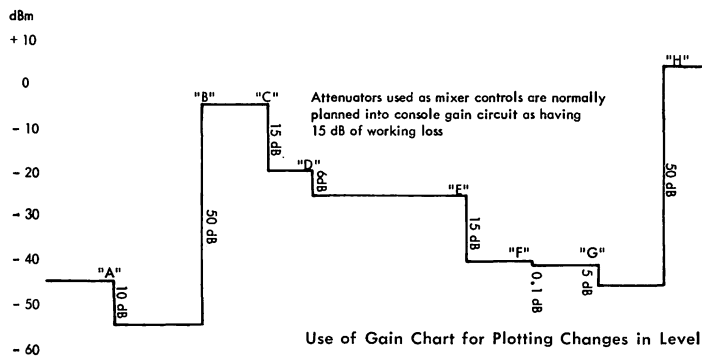

Use of Gain Chart for Plotting Changes in Level

NOTE: Passive resistance networks should be properly terminated with their specified operating impedance. This means a physical termination must be established. An amplifier may have a nominal "600-ohm input impedance," and yet, physically, be many times that. Make sure that the attenuator, loss pad, fader, etc., sees a definite termination impedance; calibration accuracy is lost if this is not done.

## HOW TO ORDER AN ALTEC ATTENUATOR OR NETWORK FROM THIS CATALOG:

Consult current ALTEC price lists to determine which controls listed herein are regularly stocked by the factory. NON-STOCK ITEMS are considered "special order" and, as such, are NOT RETURNABLE.

ALTEC Attenuators and Networks are coded to describe specific audio controls. Each code consists of:

1. A two-letter prefix in the first of the six boxes (see tables below) identifies the type of control.
2. The four-digit number (second box), obtained from the tables on specific catalog sheets, denotes the control's series-number.

3. The fourth box (following the dash) usually indicates the number of attenuators "ganged" together. In fixed mixer networks, this box is used to indicate the number of inputs (a single output is implied). In the case of fixed loss pads and VU meter extenders, the loss figure, in dB required, may be put in this box. If the loss-required figure contains a decimal, the 00 is left in the fourth box, and the loss-required figure appears at the end of the code, in parenthesis.
4. Box number five indicates input impedance.
5. Box six indicates output impedance. Since all fixed resistive networks (except "Ladder" and attenuators with a cue position) are reversible, either set of ports may be used as input or output.
6. Box seven allows notation for inclusion of detents or cue position. It is always helpful to include data on the service for which a control is intended, or other special information, such as "flats", length of shaft, special detent angle, etc., that may be required.

NOTICE: ALTEC LANSING invites special orders for any network listed in this catalog.

TABLE I: Code For Control Types

Code	Control
BP	Bridging Pads
DA	Precision Decade Attenuators
FA	Motion Picture Projection and Turntable Faders
LP	Fixed Loss Pads
MN	Mixer Networks
MP	Minimum Loss Matching Pads
PN	Precision Impedance Matching Networks
PP	Stereo Pan Pots
RA	Calibrated Attenuators and Rotary Differential Attenuators
RM	Rotary Attenuators, Mixer Controls
RP	Calibrated Grid Control Potentiometers
SM	Straight Line Attenuators, Mixer Controls
VU	VU Meter Extenders

UNBALANCED

Model Number	Circuit	Size
RM8200-01GG	Ladder	1½

TABLE II: Impedance Code

Impedance	Code	Impedance	Code
30 Ω	A	7,100 Ω	J
50 Ω	B	7,500 Ω	V
100 Ω	I	10,000 Ω	M
125 Ω	C	20,000 Ω	P
150 Ω	K	25,000 Ω	R
200 Ω	D	50,000 Ω	S
250 Ω	E	100,000 Ω	T
500 Ω	F	200,000 Ω	W
600 Ω	G	250,000 Ω	X
1500 Ω	H	500,000 Ω	Y
3900 Ω	U	1,000,000 Ω	Z
5000 Ω	L	Non-Standard	N*

\*May also mean "not applicable." Where a non-standard impedance value is required, include the value desired, in numerals, following the part number.

RM	8200	—	02	G	G	Q
Rotary Mixer	Basic Number	(Dash)	Two Gang	600 Ω Input Impedance	600 Ω Output Impedance	Cue Position

The two digits following the dash may indicate any of several things, depending on the type of control being ordered. IN A MAJORITY OF CASES, THESE TWO DIGITS WILL INDICATE THE NUMBER OF GANGS: i.e., "01" means a single-gang unit, "02" is a two-gang unit, etc. However, in the case of fixed networks where the number of gangs does not apply, these two figures are used to indicate other specifications. For example, in mixer networks they refer to the number of inputs: i.e., "03" would mean three inputs, "11" would indicate eleven inputs, etc. (up to 20). In the part number of fixed loss pads and VU Meter extenders, these two digits refer to the amount of loss (in dB) or the dBm required. Where this value requires a decimal, the numbers following the dash (-) should be listed as "00", and the amount required placed in parenthesis, following the suffix. For example, a network with a 9.5 dB loss should be ordered as "LP8004-00GG (9.5)".

Check to ensure that coding is correct for:

- (1) Basic Number Check against specifications in the appropriate table.
- (2) Gangs Make certain the digits following the dash (-) indicate the correct number of gangs (or inputs or amount of loss desired for some fixed networks).
- (3) Impedance Check the suffix to be certain that the proper input and, where applicable, output impedance is correctly coded.
- (4) Detents If the unit is a mixer\* or stereo pan pot and detents are desired, add a "D" to the suffix. If detents are

not desired on a control that normally has them, delete the "D" from the suffix of the model number.

- (5) Cue Position Specify by adding a "Q" to the suffix of the model number. (Cue positions are not available on controls having detents.)

Other information which may be included with the order is:

- (1) Shaft Length Standard shaft length is 0.87 inch from the face plate (or the bushing, if the unit is designed for center-hole mounting). If other than standard length is required, indicate the desired length on the order.
- (2) Flats on Shaft Mounting Indicate position if flats are desired. Specify center or plate mounting. (See mounting information, page 5.)

It is advisable to double-check the model number by providing information, where applicable, as to:

Circuit type  
Loss in dB per step  
Total dB loss or voltage ratio  
Input and output impedances  
Number of gangs  
Number of steps  
Detent angle

\*Mixers with detents require a special dial for proper indexing.

## STRAIGHT LINE ATTENUATORS (SM8272-8281 and SM8324-8327)

ALTEC Straight Line Attenuators, which are precision controls for signal blending, are designed for the most critical applications in musical scoring, re-recording, radio and television usage, and high quality sound reinforcement systems. These mixers feature a nylon bearing on a longitudinally-honed, chrome-plated shaft that provides almost friction-free operation. Less than 40 grams of pressure is required to alter a setting, and break-away friction is not apparent. The resistance wire and the collector rail are made of the same material as the wire (nichrome) to prevent generation of thermal voltages. Brushes are gold tipped. A dirt trap over the resistance element catches airborne particles, which greatly decreases the need for periodic cleaning and maintenance. Connections are made by a plug to the connection cable socket or a plug-in adapter, permitting rapid disassembly

for inspection. An adjustable screw (located just ahead of the knob) may be tightened or loosened to alter the pressure required to move the control knob—a useful feature for installations where a sound engineer might prefer more than 40 grams pressure. For multi-channel applications, the ALTEC Straight Line Mixer is available in 2, 3, 4, 5, and 6-gang assemblies, all operating with a single control knob.

Special frames for plug-in mounting and special escutcheons for these mixers are available as accessories and **MUST BE ORDERED SEPARATELY**. All straight line mixers are supplied with a knob; all ladders have 6-dB insertion loss; and all units have a standard impedance of 600 ohms. Other impedances are available on special order.

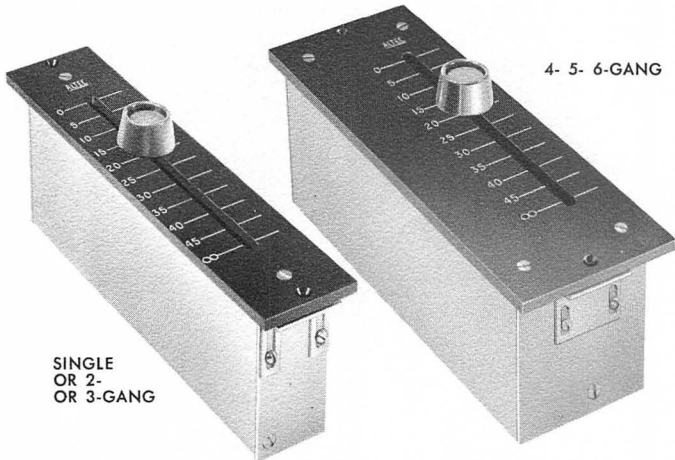

TABLE III: Dimension and Weight Information

STRAIGHT LINE CONTROLS Straight Line Mixers, Stereo Pan Pots				ACCESSORIES Escutcheons Mounting Frames	
Gangs	D	Weight (oz.)	E	F	G
1	1 1/8"	20.3	1.5" (or 1.25")	1.25"	0.750" (or 0.625")
2	1 1/8"	22.5	1.5" (or 1.25")	1.25"	0.750" (or 0.625")
3	1 1/2"	28.5	1.75"	1.625"	1.068"
4	2 3/4"	36.8	3"	2.875"	1.906"
5	2 3/4"	38.9	3"	2.875"	1.906"
6	2 3/4"	41.0	3"	2.875"	1.906"

TABLE IV: Straight Line Mixers

UNBALANCED		SPECIFICATIONS		BALANCED	
Model Number	Circuit	No. of Steps	dB per Step	Model Number	Circuit
SM8272-01GG	Ladder	Slide Wire	—	SM8277-01GG*	Slide Wire
SM8273-01GG	Ladder**	20	2	SM8278-01GG	Balanced Ladder
SM8274-01GG	Ladder**	30	1 1/2	SM8279-01GG	Balanced Ladder
SM8275-01GG	Bridged-T**	20	2	SM8280-01GG*	Balanced-H
SM8276-01GG	Bridged-T**	30	1 1/2	SM8281-01GG*	Balanced-H
SM8326-01SN	Unbalanced Pot**	20	2	SM8324-01SN	Balanced Pot
SM8327-01SN	Unbalanced Pot**	30	1 1/2	SM8325-01SN	Balanced Pot

\*Available in single, 2, or 3-gang models only (NOTE: for 2 or 3-gang version, substitute "02" or "03" for the "01" in the model number.)  
\*\*Step-Type. (Detents available on Special Order.)

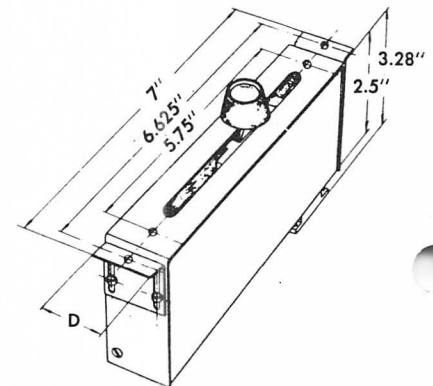

STRAIGHT LINE CONTROLS

## ACCESSORIES & WIRING INFORMATION

Escutcheons and plug-in mounting frames are not supplied with straight line controls, and must be ordered separately. All straight line controls are supplied with a standard red knob. A variety of solid-color molded knobs are also available. They should be ordered by part number:

Red	9622-2	Grey	9622-8
Yellow	9622-4	White	9622-9
Green	9622-5	Black	9622-10
Blue	9622-6		

There are several sizes and types of escutcheon plates and mounting frames for straight line controls. These should be ordered by part number, as follows:

### STRAIGHT LINE ESCUTCHEONS

For 1- and 2-gang units, black, engraved, 1 1/2 inch wide	9611
For 1- and 2-gang units, cue position, black, engraved, 1 1/2 inch wide	9630
For 1- and 2-gang units, clear, engraved, 1 1/2 inch wide	9640
For 1- and 2-gang units, cue position, clear, engraved, 1 1/2 inch wide	9641
For 1- and 2-gang units, black engraved, 1 1/4 inch wide	9636
For 1- and 2-gang units, cue position, black, engraved, 1 1/4 inch wide	9637
For 1- and 2-gang units, clear, engraved, 1 1/4 inch wide	9638
For 1- and 2-gang units, cue position, clear, engraved, 1 1/4 inch wide	9639
For 3-gang units, black, engraved	9624
For 3-gang units, cue position, black, engraved	9631
For 4-, 5-, and 6-gang units, black, engraved	9623
For 4-, 5-, and 6-gang units, cue position, black, engraved	9632
For Stereo Pan Pot, 1 channel into 2	9628
For Stereo Pan Pot, 1 channel into 3	9629
For Stereo Pan Pot, 1 channel into 5	9633

### STRAIGHT LINE MOUNTING FRAMES

For 1- and 2-gang units	9701
For 3-gang units	9702
For 4-, 5-, and 6-gang units	9703

### STRAIGHT LINE BRUSH REPLACEMENT

For straight line Brush Block Assembly, order part number	50360
For straight line Single Brush Block assembly, Step Type, order part number	50995
For straight line Double Brush Block assembly, Step Type, order part number	50996

On the bottom of each Altec Straight Line Attenuator is a connector-cable socket or a plug-in adapter with six pins. The pins are identified as A, B, C, D, E, and F, or 1, 2, 3, 4, 5, and 6. Input and output connections should be made as follows: Pin 1-A = IN; 2-B = IN (C); 3-C = OUT 4-D = OUT (C); 5-E = GND (chassis ground); and 6-F = Cue (when used).

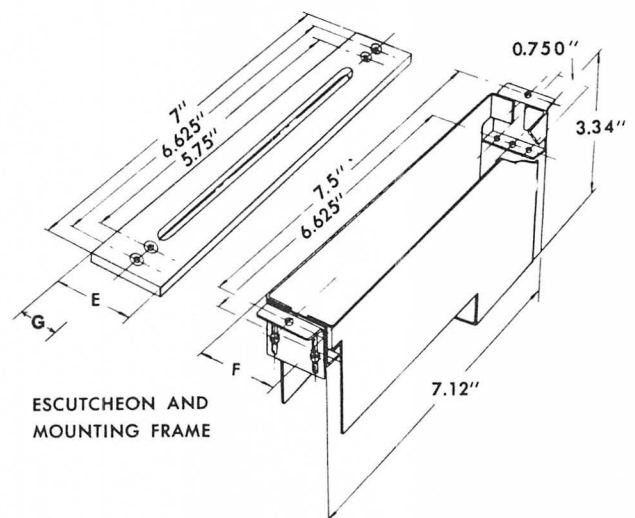

ESCUTCHEON AND MOUNTING FRAME

DETENTS  
NOT NORMALLY  
SUPPLIED

Mounting brackets are supplied on all straight line attenuators (mounting holes: 5/32" in diameter). If mounting frames are used, the mounting brackets should be removed from the control and installed on the mounting frame.

## ROTARY ATTENUATORS (RM8200-8223 and RM8225-8226)

ALTEC Rotary Attenuators, accurate controls for the blending of signals in all audio applications, have a life expectancy in excess of a million turns. These controls require no cleaning, since they are enclosed to exclude all dirt, corrosion, and moisture. Only fine silver is used in the contacts and brushes. Light, but uniform, operating pressure decreases wear. Low friction bearing ensure precise contact positioning, minimum drag, and smooth, accurate control. Only 2 inch-ounces of torque are required to alter settings for ladder circuit mixers; however, 4 inch-ounces are needed for the bridged-T types.

All connections are made to solder-terminals at the rear of the unit. Maximum cutoff and elimination of crosstalk is provided with the use of an extra "C" (common) terminal, which eliminates the usual 2-wire common, thus simplifying testing and wire changing. Case ground on all controls appears at a terminal that is completely removed from the signal ground (common).

ALTEC Rotary Attenuators are available in two frame sizes, as well as in

single, double, and triple "gang" units for multi-channel applications. They have standard input and output impedances of 600 ohms (other impedances available on special order) and are supplied with knob and dial.

Attenuators used as mixing controls do not have detents or cue positions, however either are available on special order. Attenuators with detents require a special dial for proper indexing, which should be ordered separately. A cue position requires an extra step (except on those models with 45 steps) where the cue position replaces the last step and the next-to-last step is infinity.

Only single-gang models are listed in the table. Available (except as noted) are 2-, 3-, & 4-gang models, which may be ordered by inserting the desired number of gangs in the model number. The "01" portion of the model number indicates one (or single) gang units. Substitute "02" to order a 2-gang unit, or "03" for the 3-gang unit of the model desired. For example, RM8200-01GG is the single-gang version; RM8200-02GG is the 2-gang version; etc.

3-GANG

2-GANG

SINGLE  
(shown)

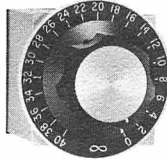

DETENTS  
NOT NORMALLY  
SUPPLIED

TABLE V: Rotary Mixers, Numbers, and Specifications

UNBALANCED			SPECIFICATIONS			BALANCED		
Model Number	Circuit	Size	No. of Steps	DB per Step	Total Degrees of Rotation	Model Number	Circuit	Size
RM8200-01GG	Ladder	1½"	20	2¼	300	RM8204-01GG	Balanced Ladder	2¼"
RM8201-01GG	Ladder	1½"	20	2	300	RM8205-01GG	Balanced Ladder	2¼"
RM8202-01GG	Ladder	1½"	30	1½	300	RM8206-01GG	Balanced Ladder	2¼"
RM8203-01GG	Ladder	2¼"	45	1	337½	RM8207-01GG*1	Balanced Ladder	2¼"
RM8208-01GG	Bridged-T	2¼"	20	2¼	300	RM8212-01GG*1	Balanced-H	2¼"
RM8209-01GG	Bridged-T	2¼"	20	2	300	RM8213-01GG*1	Balanced-H	2¼"
RM8210-01GG	Bridged-T	2¼"	30	1½	300	RM8214-01GG*1	Balanced-H	2¼"
RM8211-01GG*1	Bridged-T	2¼"	45	1	337½	RM8215-01GG*2	Balanced-H	2¼"
RM8216-01SN	Unbalanced-Pot	1½"	20	2¼	300	RM8220-01SN	Balanced-Pot	2¼"
RM8217-01SN	Unbalanced-Pot	1½"	20	2	300	RM8221-01SN	Balanced-Pot	2¼"
RM8218-01SN	Unbalanced-Pot	1½"	30	1½	300	RM8222-01SN	Balanced-Pot	2¼"
RM8219-01SN	Unbalanced-Pot	2¼"	45	1	337½	RM8223-01SN*1	Balanced-Pot	2¼"
RM8225-01GG	Ladder	1½"	30	1½	337½			
RM8226-01GG	Bridged-T	2¼"	30	1½	337½			

\*Single unit in 2-gang frame and 2-gang unit in 4-gang frame.

<sup>1</sup>Made in single and 2-gang models only.

<sup>2</sup>Made in single-gang model only.

NOTE: Mixers with potentiometer circuitry require input impedance code only. Output impedance should be N (Not Applicable) as indicated in the Table.

### ACCESSORIES

All rotary controls are supplied with knob and dial, but they may be ordered without knob and/or dial if preferred.

### KNOB

The 9607 Knob, 2" in diameter, is furnished with all equipment with the exception of the 9200A Console.

The 9608 Knob, 1¼" in diameter, is furnished with the 9200A Console.

TABLE VI: Rotary Controls

Frame Size	A & B	C	Weight (oz.)	
			1½"	2¼"
Single	1½" or 2¼"	2.30"	7	11
2-Gang	1½" or 2¼"	3.47"	10	14
3-Gang	1½" or 2¼"	4.59"	13	17
4-Gang	1½" or 2¼"	5.78"	16	20
5-Gang	1½" or 2¼"	6.87"	19	23
6-Gang	1½" or 2¼"	8.02"	22	26

NOTE: Additional gangs are available, by special order, on some combinations. Request special quote.

### ROTARY ATTENUATORS

Small size (1½" square) Rotary Attenuators may be either center-hole or plate mounted. Plate mounting holes are 1¼" apart.

The larger size Rotary Attenuators (2¼" square) should be plate mounted. Mounting holes are 1¼" and 1½" apart.

The control shafts are ¼" in diameter, but the mounting hole is drilled ⅜" in diameter to accommodate the threaded bushing. Shaft length is 7/8".

All rotary units may be opened by removing the mounting plate at the knob end of the control, then sliding the case off the unit.

### ROTARY CONTROLS

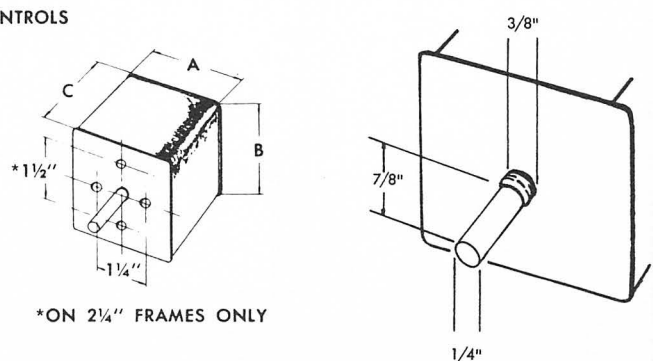
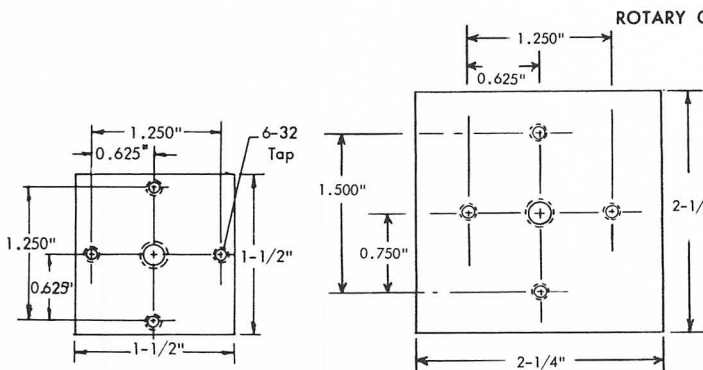

**CALIBRATED ATTENUATORS (RA8400-8418, RA8457-8474, RA8505-8506, RA8508)**

ALTEC Calibrated Attenuators are equipped with a calibrated dial and, unlike mixers, are made with detents to facilitate return to exact control settings. These attenuators are available in both unbalanced and balanced circuits. The unbalanced units are designed around "ladder" or "bridged-T" circuitry, while the balanced attenuators utilize the "balanced ladder" or "balanced-H" type of circuit, as illustrated to the right.

The insertion loss of the "T" and "H" circuit attenuators is zero. For the ladder circuit attenuators, the insertion loss is 6 dB. All models have standard input and output impedances of 600 Ohms (other desired impedances are available by special order) and are made in single, double, and triple gang types (except as noted in Table VII). Specifications for these attenuators will be found in Table VII with unbalanced models listed on the left and their balanced equivalents on the right.

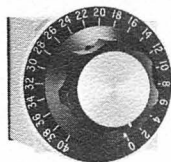

SUPPLIED WITH DETENTS

**CALIBRATED ATTENUATOR CIRCUITS**

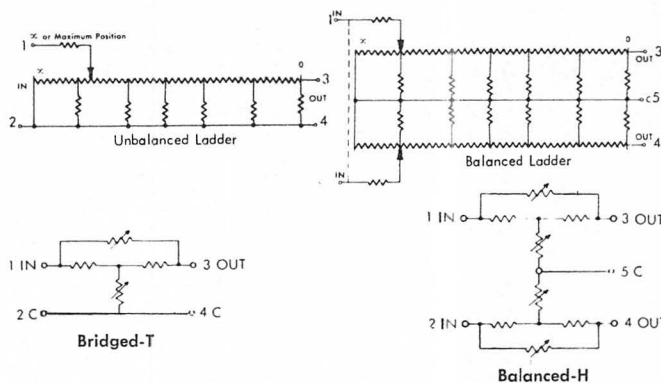

TABLE VII: Calibrated Attenuators										
UNBALANCED			SPECIFICATIONS					BALANCED		
Model Number	Circuit	Size	No. of Steps	DB per Step	Total DB Loss	Detent Angle	Total Degrees of Rotation	Model Number	Circuit	Size
RA8400-01GGD	Ladder	1½	10	1	10	15°	150°	RA8457-01GGD	Balanced Ladder	1½
RA8401-01GGD	Ladder	1½	20	1	20	15°	300°	RA8458-01GGD	Balanced Ladder	2¼
RA8402-01GGD	Ladder	1½	30	1	30	11¼°	337½°	RA8459-01GGD	Balanced Ladder	2¼
RA8403-01GGD	Ladder	1½	10	2	20	15°	150°	RA8460-01GGD	Balanced Ladder	1½
RA8404-01GGD	Ladder	1½	20	2	40	15°	300°	RA8461-01GGD	Balanced Ladder	2¼
RA8405-01GGD	Ladder	1½	10	5	50	15°	150°			
RA8406-01GGD	Bridged-T	1½	10	1/10	1	15°	150°	RA8462-01GGD	Balanced-H	2¼
RA8407-01GGD	Bridged-T	2¼	20	1/10	2	15°	300°	RA8463-01GGD*	Balanced-H	2¼
RA8408-01GGD	Bridged-T	1½	10	½	5	15°	150°	RA8464-01GGD	Balanced-H	2¼
RA8409-01GGD	Bridged-T	2¼	20	½	10	15°	300°	RA8465-01GGD*	Balanced-H	2¼
RA8410-01GGD	Bridged-T	1½	10	1	10	15°	150°	RA8466-01GGD	Balanced-H	2¼
RA8411-01GGD	Bridged-T	1½	15	1	15	10°	150°	RA8467-01GGD	Balanced-H	2¼
RA8412-01GGD	Bridged-T	2¼	20	1	20	15°	300°	RA8468-01GGD*	Balanced-H	2¼
RA8413-01GGD	Bridged-T	2¼	30	1	30	11¼°	337½°	RA8469-01GGD*	Balanced-H	2¼
RA8414-01GGD	Bridged-T	1½	10	2	20	15°	150°	RA8470-01GGD	Balanced-H	2¼
RA8415-01GGD	Bridged-T	1½	15	2	30	10°	150°	RA8471-01GGD	Balanced-H	2¼
RA8416-01GGD	Bridged-T	2¼	20	2	40	15°	300°	RA8472-01GGD*	Balanced-H	2¼
RA8417-01GGD	Bridged-T	2¼	30	2	60	11¼°	337½°	RA8473-01GGD*	Balanced-H	2¼
RA8418-01GGD	Bridged-T	1½	10	5	50	15°	150°	RA8474-01GGD	Balanced-H	2¼
			20	1/10	2	15°	300°	RA8506-01GGD*	Balanced-H	1½
RA8508-01GGD	Bridged-T	2¼	45	1	45	7½°	337½°			

\*Single gang unit in 2-gang frame and 2-gang unit in 4-gang frame. No 3-gang unit available. NOTE: Last step can be used for "Infinity" or "Off", but 1 step of calibrated attenuation will be lost.

**CALIBRATED GRID CONTROL POTENTIOMETERS (RP8600-8606, RP8621-8627, RP8640-8643)**

ALTEC Calibrated Grid Control Potentiometers are designed to ensure calibration into an open circuit, such as the grid of a Class "A" amplifier tube. ALTEC Grid Control Potentiometers are available with an unbalanced

configuration for single grids, and with a balanced configuration for push-pull grid circuitry. All units are equipped with detents, and all are supplied with knob and dial. Other specifications are listed in Table VIII.

TABLE VIII: Calibrated Grid Control Potentiometers								
UNBALANCED		SPECIFICATIONS					BALANCED	
Model Number	Size	No. of Steps	DB per Step	Total DB Loss	Detent Angle	Total Degrees of Rotation	Model Number	Size
RP8600-01SND	1½	10	5	50	15°	150°	RP8621-01SND	1½
RP8601-01SND	1½	15	5	75	15°	225°	RP8622-01SND**	1½
RP8602-01SND	1½	20	3	60	15°	300°	RP8623-01SND	2¼
RP8603-01SND	1½	30	1	30	11¼°	337½°	RP8624-01SND	2¼
RP8604-01SND	1½	30	2	60	11¼°	337½°	RP8625-01SND	2¼
RP8605-01SND	2¼	40	1	40	7½°	300°	RP8626-01SND*	2¼
RP8606-01SND	2¼	40	2	80	7½°	300°	RP8627-01SND*	2¼
RP8640-01SND	1½	20	2	40	15°	300°	RP8643-01SND	1½

\*Single gang unit in 2-gang frame and 2-gang unit in 4-gang frame. Not available as 3-gang unit.  
 \*\*Detent angle of RP8622-01SND is 11¼°.

NOTE: Impedance should be specified as a part of the model number by the appropriate code letter (see Ordering Information and Impedance Code on Page 3. In this chart, S (50,000 Ω) is used in the model number only as an example. Since there is no output impedance specified in potentiometer circuits, the code letter N (not applicable) should be used for the output impedance section of the model number. ALTEC Calibrated Grid Control Potentiometers are available with the following impedance values:

1000 Ω (N - Specify value)	10,000 Ω (M)	50,000 Ω (S)	250,000 Ω (X)
5000 Ω (L)	25,000 Ω (R)	100,000 Ω (T)	500,000 Ω (Y)

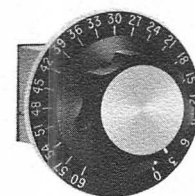

SUPPLIED WITH DETENTS

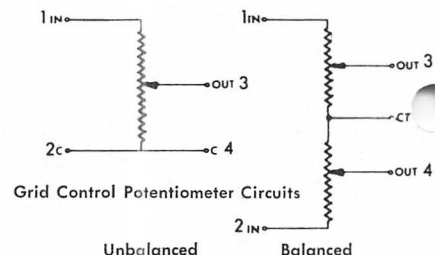

## PRECISION MEASURING EQUIPMENT

The Altec series of Precision Measuring Equipment, primarily intended for use in Gain Sets and for measurements of transmission levels, consists of Altec Precision Decade Attenuators and Altec Precision Impedance Matching Networks. Fixed networks such as Fixed Loss Pads, Minimum Loss Matching Pads, and Bridging Pads also are included in this section.

### PRECISION DECADE ATTENUATORS (DA8735-8746)

The Altec Precision Decade Attenuator is designed as a 10-step unit with a 15-degree detent angle with a total rotation of 150 degrees. To insure best results and continuing accuracy over an indefinite period, steady sine wave power input levels should not exceed 1 watt. On the other hand, program material up to 5 watts can be handled for an unlimited time. These attenuators are available in either the "T" or "H" type of circuitry, with 0.1, 1, or 10 db steps, and with either 150 or 600 ohms impedance. A knob and dial is supplied with each unit. Additional specifications are listed in Table IX.

SUPPLIED WITH DETENTS

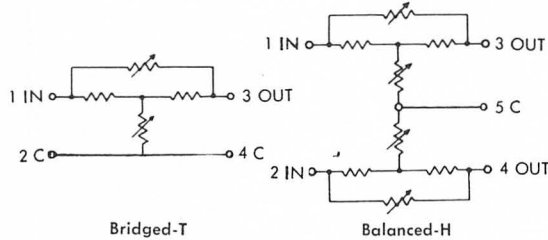
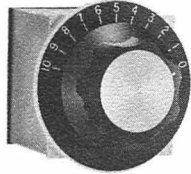

### PRECISION DECADE SET (9711, 9712)

The Altec Precision Decade Attenuator model 9711 is a combination of three precision decade attenuators, DA8742-01GGD, DA8744-01GGD, and DA8746-01GGD, which have been assembled in one case with separate controls, but common input and output terminals. Thus, one precision measuring set does the work of three. The 9711 is an unbalanced bridged-T circuit, matching a 600-ohm input circuit, and provides up to 111 dB of attenuation in steps of 0.1 dB each. As with the individual decade attenuators, program material up to 5 watts can be handled for an unlimited time. The model 9712 is similar to the 9711, but is available in a balanced-H circuit.

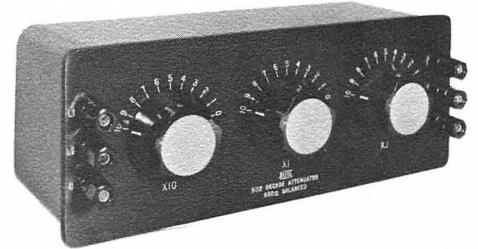

Model Number	Circuit	Size	Impedance	DB per Step	Total DB Loss
DA8735-01KKD	Unbalanced-T	1½	150Ω	0.1	1
DA8736-01GGD	Unbalanced-T	1½	600Ω	0.1	1
DA8737-01KKD	Unbalanced-T	1½	150Ω	1	10
DA8738-01GGD	Unbalanced-T	1½	600Ω	1	10
DA8739-01KKD	Unbalanced-T	1½	150Ω	10	100
DA8740-01GGD	Unbalanced-T	1½	600Ω	10	100
DA8741-01KKD	Balanced-H	2¼	150Ω	0.1	1
DA8742-01GGD	Balanced-H	2¼	600Ω	0.1	1
DA8743-01KKD	Balanced-H	2¼	150Ω	1	10
DA8744-01GGD	Balanced-H	2¼	600Ω	1	10
DA8745-01KKD	Balanced-H	2¼	150Ω	10	100
DA8746-01GGD	Balanced-H	2¼	600Ω	10	100

### PRECISION VARIABLE IMPEDANCE MATCHING NETWORKS (PN8747-8754)

Altec Precision Variable Impedance Matching Networks consist of a series of fixed matching pads selectable by a rotary switch. These networks are ideal for Gain Sets since they are designed to permit a high degree of accuracy in matching impedances and are calibrated for relative losses due to matching of unequal impedance ratios. The networks are available in both the "T" and "H" type of circuit, and with 150- or 600-ohm input impedance with a series of output impedances. These units have a total rotation of 140 degrees and detent angles of 20 degrees. A knob and dial is supplied with each network. Since these networks are reversible, they may be matched to either input or output impedances. The "H" circuit networks may be balanced to common center or to ground. Other specifications are listed in Table X.

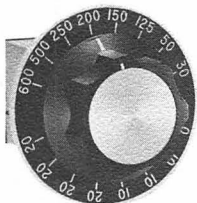

SUPPLIED WITH DETENTS

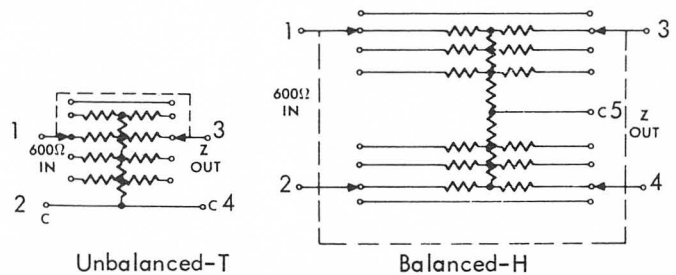

UNBALANCED		SPECIFICATIONS										BALANCED		
Model Number	Circuit	Size	Input Impedance	Insertion Loss in DB for Output Impedance								Model Number	Circuit	Size
				30Ω	50Ω	125Ω	150Ω	200Ω	250Ω	500Ω	600Ω			
PN8747-01KND	Unbalanced-T	1½	150Ω	20	20	20	0	10	10	10	20	PN8751-01KND	Balanced-H	2¼
PN8748-01KND	Unbalanced-T	1½	150Ω	20	20	20	20	20	20	20	20	PN8752-01KND	Balanced-H	2¼
PN8749-01GND	Unbalanced-T	1½	600Ω	20	20	20	20	10	10	10	0	PN8753-01GND	Balanced-H	2¼
PN8750-01GND	Unbalanced-T	1½	600Ω	20	20	20	20	20	20	20	20	PN8754-01GND	Balanced-H	2¼

## MOTION PICTURE PROJECTION AND TURNTABLE FADERS (FA8800-8801, FA8804-8805)

In the projection of motion pictures, the changeover from one reel of film to the next should be imperceptible... not only visually, but audibly as well. In radio broadcasting, the switching over from one turntable to another must be equally subtle. Altec Motion Picture Projection and Turntable Faders are designed to accomplish these functions.

The Altec Fader is available in ladder or potentiometer circuit configuration,

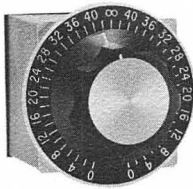

SUPPLIED WITH DETENTS

and with either 16 or 22 steps on each side of infinity. Knob and dial are supplied with each unit, and the calibrated dials are marked in red on the right side and in white on the left side for ease of operation. Detents are at 10 degrees on the 16-step model and at 7 1/2 degrees on the 22-step unit. Impedances up to 600 ohms are available, as well as values up to 500,000 ohms for the potentiometer models. Available for stereo application are 2-gang or 4-gang units on special order. For other than stereo application these units may be ordered as single, 2-, 3-, or 4-gang faders. Table XI lists other specifications for these units and the circuitry is shown in the illustration below.

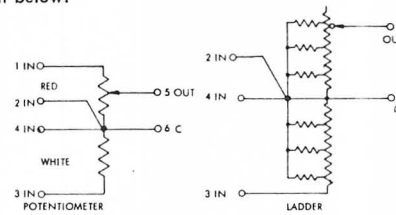

Model Number	Circuit	No. of Steps On Each Side of Infinity	Total No. of Steps	DB per Step	Range	Detent Degrees	Total Rotation	Frame Size
FA8800-01GGD	Unbalanced Ladder	16	32	3	0-45-∞-45-0	10°	320°	1 1/2"
FA8801-01GGD	Unbalanced Ladder	22	45	2	0-42-∞-42-0	7 1/2°	337 1/2°	2 1/4"
FA8804-01SND	Unbalanced Pot	16	32	3	0-45-∞-45-0	10°	320°	1 1/2"
FA8805-01SND	Unbalanced Pot	22	45	2	0-42-∞-42-0	7 1/2°	337 1/2°	2 1/4"

## STEREO PAN POTENTIOMETERS (PP8806-8809, PP8812, PP8814)

The advent of stereo and multi-channel transmission created problems in transferring the apparent position of a sound source from one section of the recording field to another. The arrival time of a sound will influence the apparent position of its source, and the intensity of that sound can offset the effects of its arrival time. A change of only 3 db in intensity is enough to displace the apparent source across the recorded field, an effect which may be controlled by the use of Altec Stereo Pan Potentiometers.

Either a two-channel or a three-channel pan pot may be used to pick up a monaural sound and transfer it to any "geometric" position desired in the final stereo transmission. A stereo pan potentiometer is a two-channel system. Two oppositely wound controls are arranged in such a way that the 3 db down point of each control occurs at zero degrees. (For a three-channel system, three controls are ganged so that the 3 db down point

occurs at 45 degrees to either side of the center.) At either 90-degree position, the extreme opposite channel is at infinite attenuation.

The unusual taper of each winding demands 16 positions in each unit in order to attain the smoothest transition throughout the audible range of control. Attenuation to extremes is rapid at both ends, but low in the region of overlap from one section to another. This attenuation rate is precise and conforms to the exacting calculations which govern angular displacement in the sound field as indicated by changes in level.

These Altec Stereo Pan Pots have a 12-dB insertion loss and are designed for 600-ohm input and output impedances. The rotary models have 270 degrees of rotation. Special frames for plug-in mounting and special escutcheons for straight line stereo pan pots are available as accessories. Dial and knob are supplied with the rotary model, but straight line units are supplied with knob only. Additional specifications are listed in Table XII and the circuitry is shown in the illustrations below.

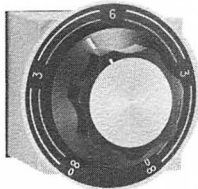

SUPPLIED WITHOUT DETENTS

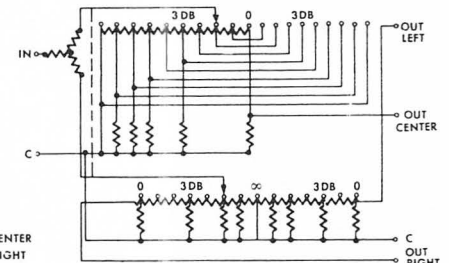
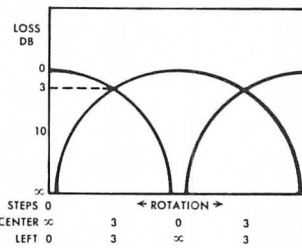
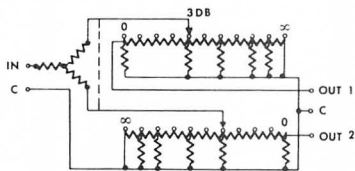
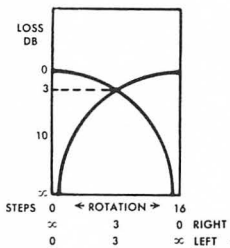
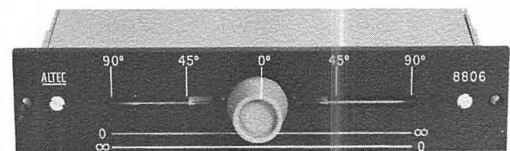

Straight Line Model Number	Rotary Model Number	Channels	No. of Steps	Attenuation	Escutcheon Required
PP8806-02GG	PP8808-02GG	1 into 2	16 (Right) (Left)	∞ --3 db -- 0 0 --3 db -- ∞	9628
PP8807-03GG	PP8809-03GG	1 into 3	22 (Right) (Left)	0 --3 db -- ∞ --3 db -- 0 ∞ --3 db -- 0 --3 db -- ∞	9629
PP8812-05GG	PP8814-05GG	1 into 5	40* (Right) (Left)	∞ --3 db -- 0 --3 db -- ∞ --3 db -- 0 --3 db -- ∞ 0 --3 db -- ∞ --3 db -- 0 --3 db -- ∞ --3 db -- 0	9633

\*Rotary Model PP8814-05GG has 41 steps. Mounting Frame: 9701 Available for straight line models.

## ROTARY DIFFERENTIAL ATTENUATOR (RA8811)

Similar to the Stereo Pan Pot, the Altec Rotary Differential Attenuator is a balance control. Unlike the Pan Pot, it does not attenuate to infinity at either end, but does provide up to 10 db of attenuation in twenty steps of 0.5 db each. Both sections are at -5 db when the unit is set at zero. The Differential Attenuator should be ordered by model number (RA8811-01GG). It is 2 1/4 inches square by 2.30 inches in depth, and weighs 11 ounces.

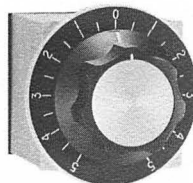

SUPPLIED WITHOUT DETENTS

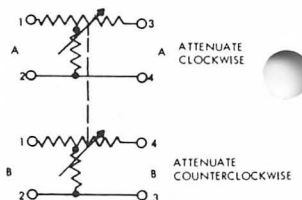

Available only in unbalanced circuit



## ALTEC VU METER RANGE EXTENDERS

Altec has VU Meter Range Extenders available as rotary, adjustable and fixed attenuators. They are designed to extend the range of standard VU meters.

### VARIABLE ROTARY VU METER RANGE EXTENDERS

(8700-8712)

Each Altec Variable Rotary VU Meter Range Extender consists of a 3900-ohm bridged-T attenuator with building-out resistors at the input. With the 3600-ohm series resistor in the circuit (see figure to right), the input impedance is 7500 ohms, and the output impedance is 3900 ohms. Two fixed resistors (3100 and 500 ohms) permit the range to start at +4 VU. The terminals of these resistors appear at the back of the unit to permit use of wire-wound adjusting potentiometers for stereo balance or calibration simply by selection of the appropriate solder terminal.

Altec Variable Rotary VU Meter Range Extenders, available for 3900-ohm impedance only, may be ordered in single-, 2-, 3-, or 4-gang models. All models are supplied with a knob and dial. Other specifications are listed in Table XIII.

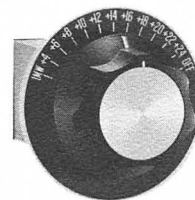
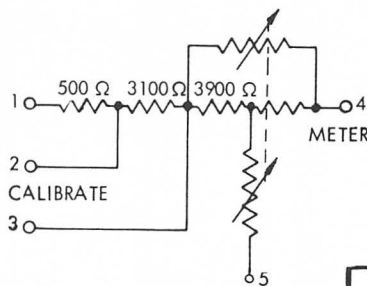

SUPPLIED WITH DETENTS

TABLE XIII: Rotary VU Meter Range Extenders

Model Number	No. of Steps	DB per Step	Range Clockwise	Detent Angle	Total Degrees of Rotation	Size
VU8700-01VUD	10	1	+4 TO +14	15°	150°	1 1/2
VU8701-01VUD	10	2	+4 TO +24	15°	150°	1 1/2
VL8702-01VUD	12	1	1 MW +4 TO +14 & OFF	11 1/4°	135°	1 1/2
VU8703-01VUD	12	2	1 MW +4 TO +24 & OFF	11 1/4°	135°	1 1/2
VU8704-01VUD	16	1	+4 TO +20	15°	240°	2 1/2
VU8705-01VUD	15	2	+4 TO +34	15°	225°	2 1/4
VU8706-01VUD	20	1	+4 TO +24	15°	300°	2 1/4
VU8707-01VUD	20	2	+4 TO +44	15°	300°	2 1/4
VU8708-01VUD	18	1	1 MW +4 TO +20 & OFF	15°	270°	2 1/4
VU8709-01VUD	20	2	1 MW +4 TO +40 & OFF	15°	300°	2 1/4
VU8710-01VUD	30	1	+4 TO +34	11 1/4°	337 1/2°	2 1/4
VU8711-01VUD*	40	1	+4 TO +44	7 1/2°	300°	2 1/4
VU8712-01VUD*	42	1	1 MW +4 TO +44 & OFF	7 1/2°	315°	2 1/4

\*Available as single-gang in 2-gang frame only.

### ADJUSTABLE (By Strapping) VU METER RANGE EXTENDER (VU8010)

The Altec Adjustable VU Meter Range Extender (VU8010-00VU) inserts a fixed loss into a VU meter circuit, permitting the range of the meter to be extended to cover additional levels. It is designed to bridge 600-ohm lines and may be used in the 3900-ohm or the 7500-ohm configuration. Figure 13A illustrates the circuitry of this unit which may be strapped to provide the meter range required.

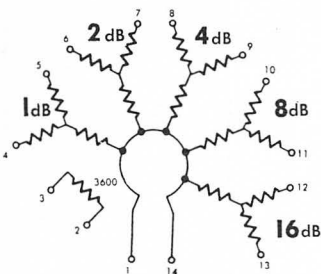

FOR DIMENSIONAL INFORMATION ON FIXED NETWORK CASES SEE PAGE 11

### FIXED VU METER RANGE EXTENDER (VU8011)

The Altec Fixed VU Meter Range Extender serves the same purpose as the other extenders, but is designed for those installations where a rotary or an adjustable extender is not needed. The model number of the Fixed VU Meter Range Extender should specify the value of the required pad. For example: model number VU8011-19VU is a fixed extender which will enable the VU meter to indicate 0 db for a true level of +15 dbm, or, for a 0 db indication for a true level of +12 dbm, model number VU8011-16VU should be ordered. To order, see representative ordering information below.



Model No.	Pad Loss	VU Reading	dBm
8011-04VU	0 dB	0 VU	= +4
8011-05VU	1 dB	0 VU	= +5
8011-06VU	2 dB	0 VU	= +6
8011-16VU	12 dB	0 VU	= +12
8011-19VU	15 dB	0 VU	= +15

FOR DIMENSIONAL INFORMATION ON FIXED NETWORK CASES SEE PAGE 11

### BASIC VU METER CIRCUITS WITH CORRECT IMPEDANCES INDICATED

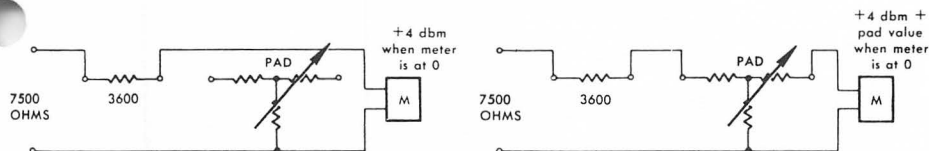

9

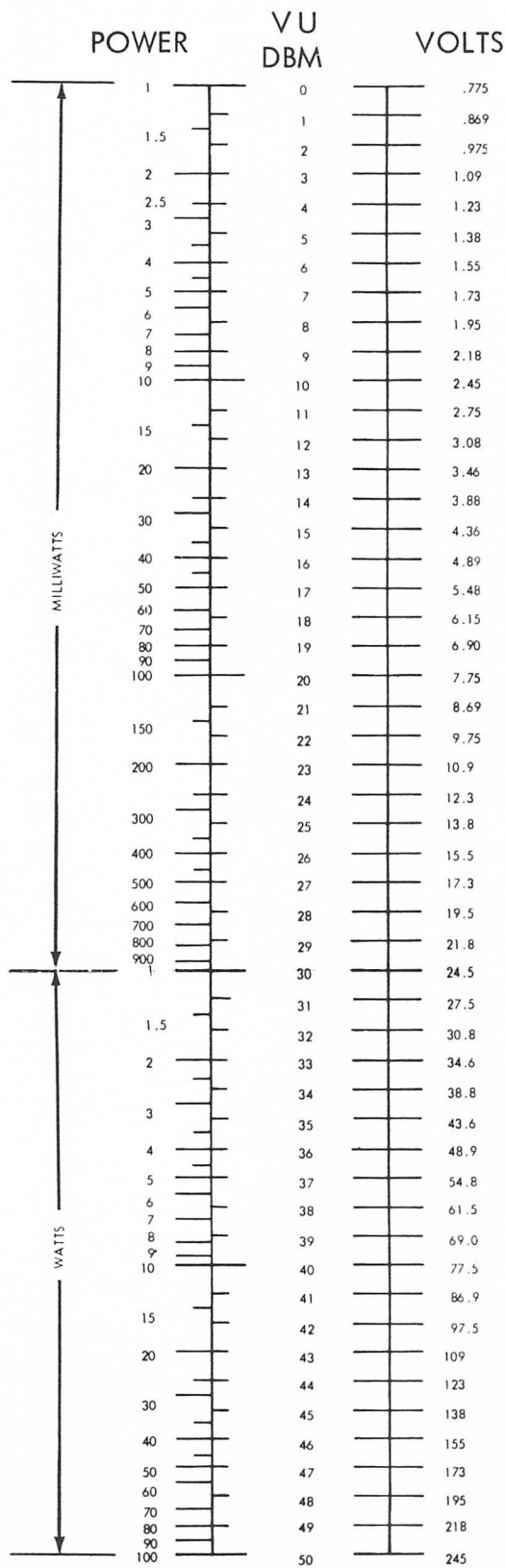

For use with 600-Ohm line

## MIXER NETWORKS (MN8000-8001)

Mixer Networks should be used where two or more attenuator controls are combined to build a mixer system. They allow a number of input signals to be paralleled and matched to the desired line impedance. The Altec series of Mixer Networks will handle any number of mixer branches up to 20 (more on special order) and, because they are reversible, may be used not only as mixer or combining networks, but also as splitting networks — by inverting the input and output. Altec Mixer Networks will sustain steady sine-wave tones up to a level of +30 dBm (1 watt). Designed for a standard impedance of 600 ohms, they may be ordered for 150-ohm impedance and are available in both the unbalanced (MN8000- series) or

the balanced (MN8001- series) configuration as indicated in the illustration below.

To order, specify the model number including the number of inputs and the impedance desired. Table XIV lists only the unbalanced models and will serve as an ordering guide. To order a balanced version, merely substitute the MN8001- series number for the basic model number shown in the table. For example: MN8000-04GG is an unbalanced mixer network with four inputs and 600-ohm impedance. MN8001-04GG is the balanced version, also with four inputs and 600-ohm impedance. (See Page 3 for detailed ordering information including the impedance code.)

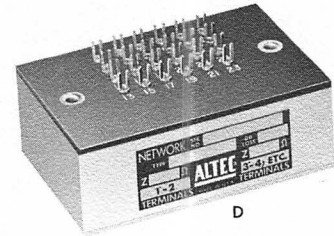
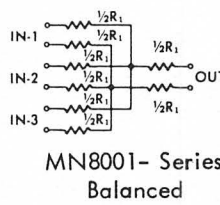
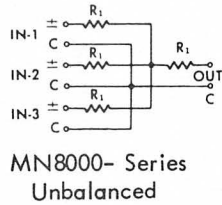
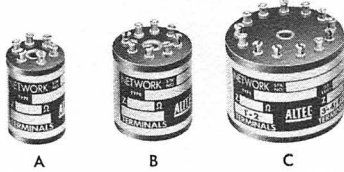

**TABLE XIV: Mixer Networks**

Model Number*	Number of Inputs	DB Loss	Case Size	Model Number*	Number of Inputs	DB Loss	Case Size
MN8000-02GG	2	6.0	A	MN8000-12GG	12	21.6	D
MN8000-03GG	3	9.5	B	MN8000-13GG	13	22.3	D
MN8000-04GG	4	12.0	C	MN8000-14GG	14	22.9	D
MN8000-05GG	5	14.0	C	MN8000-15GG	15	23.5	D
MN8000-06GG	6	15.6	C	MN8000-16GG	16	24.1	D
MN8000-07GG	7	16.9	D	MN8000-17GG	17	24.6	D
MN8000-08GG	8	18.1	D	MN8000-18GG	18	25.1	D
MN8000-09GG	9	19.1	D	MN8000-19GG	19	25.6	D
MN8000-10GG	10	20.0	D	MN8000-20GG	20	26.0	D
MN8000-11GG	11	20.8	D				

\*Model numbers shown are for unbalanced. Use MN8001- series for balanced circuits.

FOR DIMENSIONAL  
INFORMATION ON  
FIXED NETWORK  
CASES SEE  
PAGE 11

## REPRESENTATIVE MIXER CIRCUITS

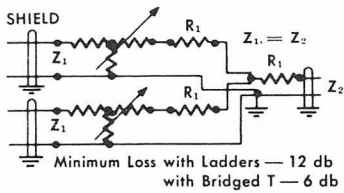

$$\frac{N-1}{N+1} Z = R_1 \quad N = \text{Number of Inputs}$$

TWO-POSITION MIXER

**TABLE XV: R<sub>1</sub> Value in Ohms for Various Mixer Circuits**

Impedance	Two Position	Three Position	Four Position	Five Position	Six Position	Eight Position
30	10	15	18	20	21.42	23.3
50	16.6	25	30	33.3	35.7	38.8
150	50	75	90	100	107	116.8
200	66.6	100	120	133	142.8	155.5
250	83.3	125	150	166	178.5	194.6
500	166	250	300	333	357	388
600	200	300	360	400	428.4	466

**Minimum Loss Values (in Decibels)**

	Two Position	Three Position	Four Position	Five Position	Six Position	Eight Position
Ladder Circuit	12	15.5	18	20	21.6	24.1
Bridged-T Circuit	6	9.5	12	14	15.5	18.1

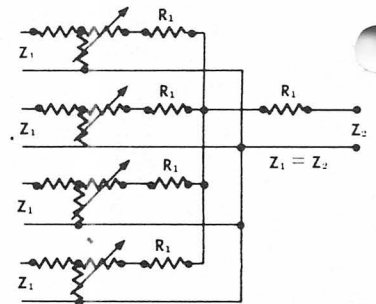

Minimum Loss  
with Ladders — 18 db  
with Bridged T — 12 db

FOUR-POSITION MIXER

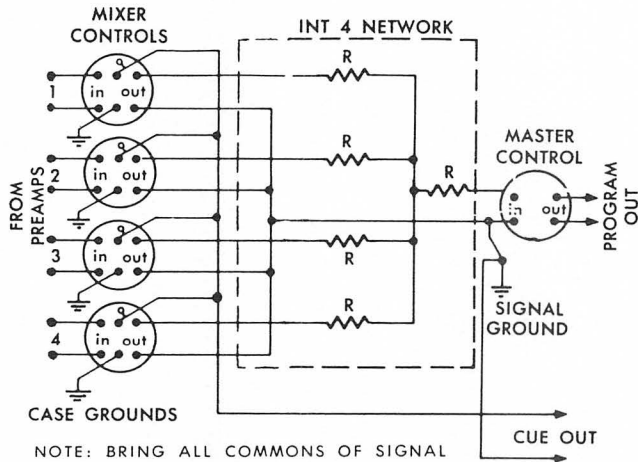

NOTE: BRING ALL COMMONS OF SIGNAL GROUND SEPARATELY TO ONE POINT. DO NOT BUS. IT IS PERMISSABLE TO BUS CASE GROUNDS.

If attenuators are switched to two different mixer nets, each Q circuit should be isolated with a line-to-line transformer.

### PARALLEL MIXER CIRCUIT

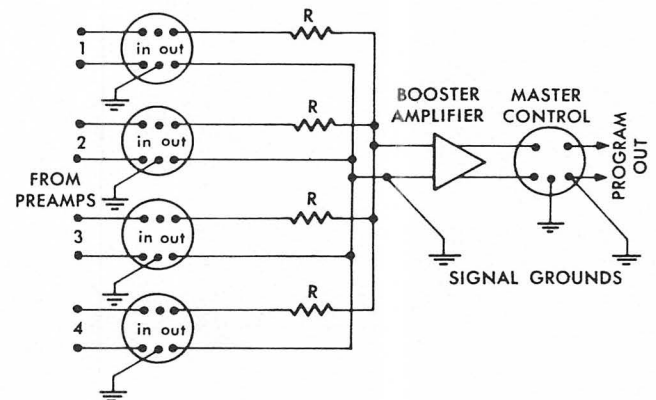

### MINIMUM LOSS PARALLEL MIXER CIRCUIT

## BRIDGING, MATCHING, AND LOSS PADS

Occasionally the audio engineer will encounter a situation where an amplifier provides more gain than is desired. To compensate for this condition, a Loss Pad may be used to protect other equipment in the line from possible overload without adding any distortion to the signal or program material. Also, a Loss Pad can be used to provide impedance stabilization between circuits.

### ADJUSTABLE LOSS PAD (Unbalanced Circuit) (LP8012)

The Altec LP8012-00GG (unbalanced-T circuit) is an adjustable fixed-loss pad for those installations where the value of the pad must be changed from time to time. These fixed loss pads permit selection (by strapping) of any loss up to 63 dB in 1 dB steps. The maximum power handling capacity is +30 dBm (1 watt).

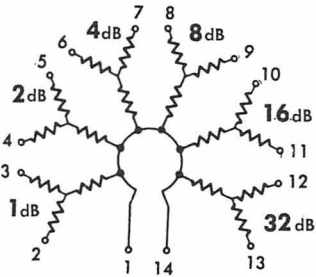

#### STRAPPING EXAMPLE:

3 dB pad = strap 3-4.  
Input on 1 & 2,  
Output on 5 & 14.

LP8012-00GG

### BRIDGING PADS (BP8008-8009)

Altec Bridging Pads are designed for those applications where high impedance bridging is desired across a 600-Ohm line output. These bridging pads are available in unbalance (BP8008-series) and balanced (BP8009-series) configurations, as illustrated below. Input and output impedances should be specified (as with Minimum Loss Matching Pads) by code as a part of the model number when bridging pads are ordered. For example: an unbalanced bridging pad with a 15,000-Ohm input and a 600-Ohm output is model number BP8008-00MG. Detailed ordering information will be found on Page 3.

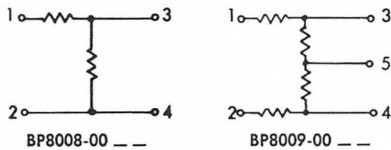

Bridging Pad Circuits

### MINIMUM LOSS MATCHING PADS

Altec Minimum Loss Matching Pads are designed for the exact matching of frequently used line impedances. The combinations available and the corresponding amount of loss in dB is shown in Table XVI. Losses greater than the minimum loss specified in the Table are available on special order. For example: Minimum loss specified for the 150-to-600 pad is 11.43 db, but losses greater than (although not less than) that value are available for the 150-to-600 pad on special order.

These Altec Minimum Loss Matching Pads are available in unbalanced (L) and balanced (U) circuitry. The MP8003-series are balanced while the MP8002-series are unbalanced as shown in the illustrations below. To order: specify the model number and the input and output impedance desired. For example: the MP8003-00GB is a balanced pad with an input impedance of 600 Ohms (G) and an output impedance of 50 Ohms (B).

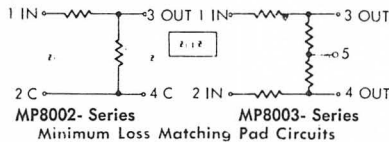

Minimum Loss Matching Pad Circuits

TABLE XVI: Minimum Loss Matching Pad Impedance Chart (in dB)

Input Impedance (in ohms)	Output Impedance (in ohms)							
	30	50	125	150	200	250	500	600
600	18.92	16.63	12.33	11.43	9.95	8.73	3.76	0
500	18.11	15.79	11.43	10.52	8.96	7.65	0	3.76
250	14.95	12.54	7.65	6.47	4.18	0	7.65	8.73
150	13.91	11.44	6.19	4.74	0	4.18	8.96	9.95
125	12.53	8.93	3.76	0	4.74	6.47	10.52	11.43
75	11.63	8.97	0	3.76	6.19	7.65	11.43	12.33
50	6.47	0	8.97	9.96	11.44	12.54	15.79	16.63
30	0	6.47	11.63	12.53	13.91	14.95	18.11	18.92

### FIXED LOSS PADS (Balanced & Unbalanced Circuits) (LP8004-8005)

These Altec Fixed Loss Pads are available in unbalanced-T (LP8004-series) or balanced-H (LP8005-series) circuits and in any amount of loss up to 60 dB. Standard impedance is 600 ohms, but other impedance values are available on special order.

To order, specify the model number, amount of loss required and impedance value. For example: LP8004-30GG is an unbalanced pad with a 30 dB loss and 600 ohms impedance (see Page 3 for the impedance code), and a balanced pad with a 23-dB loss and 150-ohm impedance would be model number LP8005-23KK.

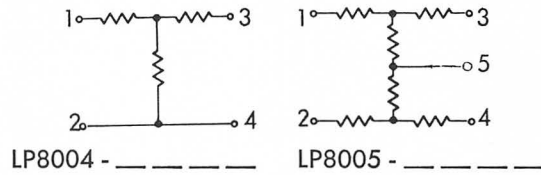

### ADJUSTABLE LOSS PAD (Balanced Circuit) (LP8013)

The Altec LP8013-00GG (balanced-H circuit) is an adjustable fixed-loss pad the same as the LP8012-00GG, except that it represents a balanced-H circuit. Any loss up to 63 dB in 1 dB steps is permitted by simply strapping the appropriate terminals, and it has a maximum power handling capacity of +30 dBm.

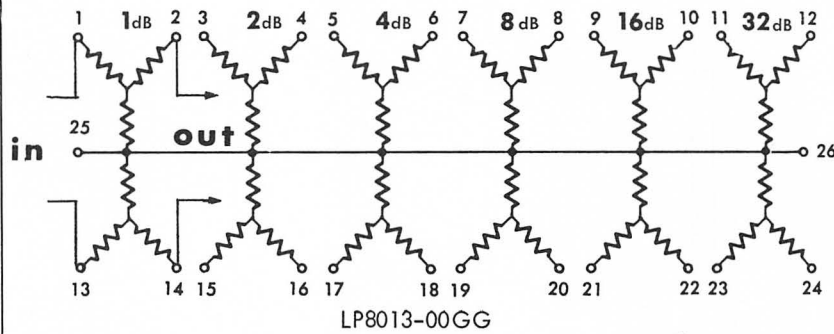

#### STRAPPING EXAMPLE:

3 dB pad = strap 2-3 and 14-15.  
Input on 1 & 13,  
Output on 4 & 16.

5 dB pad = strap 2-5 and 14-17.  
Input on 1 & 13,  
Output on 6 & 18.

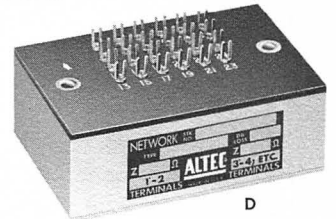

LP8013-00GG

### DIMENSIONS AND WEIGHT INFORMATION

Type	Dimensions	Weight
A	3/4" in diameter x 1 1/16" high	Less than 1/2 ounce
B	1" in diameter x 1 1/16" high	Less than 1/2 ounce
C	1 1/2" in diameter x 1 1/16" high	Less than 1/2 ounce
D	2" wide x 3" long x 1 1/16" high	Approximately 3 ounces

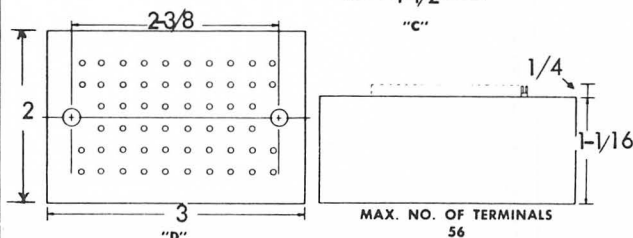
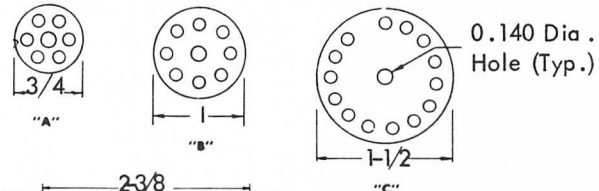
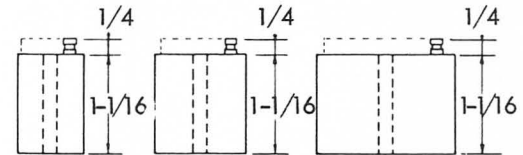

Specifications and components subject to change without notice. Overall performance will be maintained or improved.

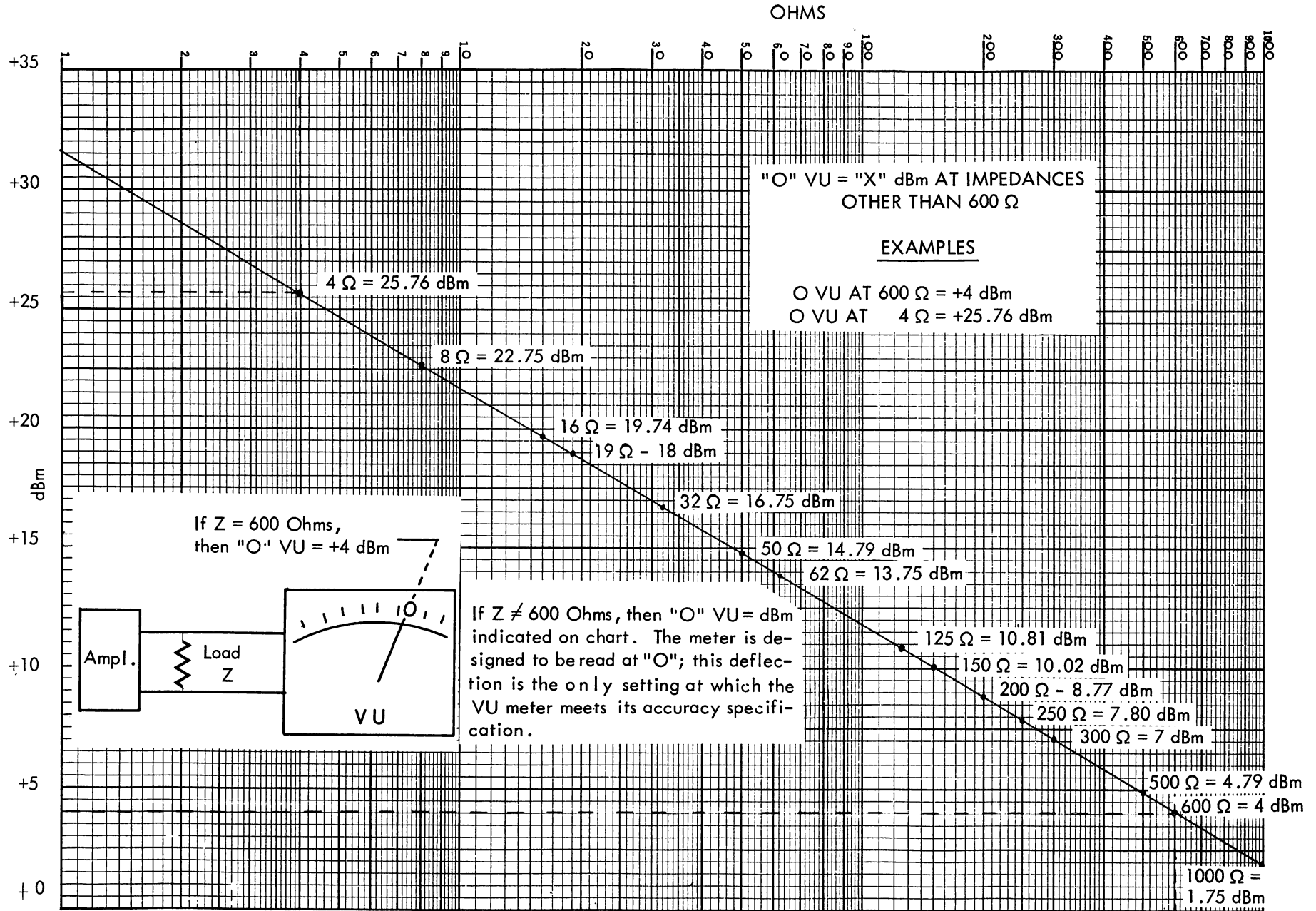

**NOTICE**

We recommend that you obtain your Altec products from factory trained authorized Altec Sound Contractors and Distributors. This will assure you of proper installation, a continuing source of knowledgeable advice, service, and quick warranty protection.