

OPERATING INSTRUCTIONS

Reference Documents for Incremental Power System:

CAUTION: No user-serviceable parts inside. Hazardous voltage may be encountered within the chassis. Installation and Service information within this document is for use only by ALTEC sound contractors, factory authorized warranty stations and qualified service personnel.

IMPORTANT: Il est enjoint à l'utilisateur de ne pas réparer lui-même les pièces internes de l'appareil, des courants à haute tension pouvant passer à l'intérieur du châssis. Les renseignements inclus dans ce document sont destinés uniquement à l'usage des installateurs agréés des systèmes acoustiques ALTEC, des centres de réparation sous garantie autorisés, ainsi que du personnel d'entretien qualifié.

42-02-045291	Modular Block Diagram Kit
42-02-045284	Model 2220/2221 Input Modules
42-02-045285	Model 2250/2250SA Driver Modules
42-02-045286	Model 2251/2251SA Driver Modules
42-02-045287	Model 2252/2252SA Driver Modules
42-02-045288	Model 2275 Power Amplifier Module
42-02-045362	Model 2276 Power Amplifier Module
42-02-045289	Main Frame

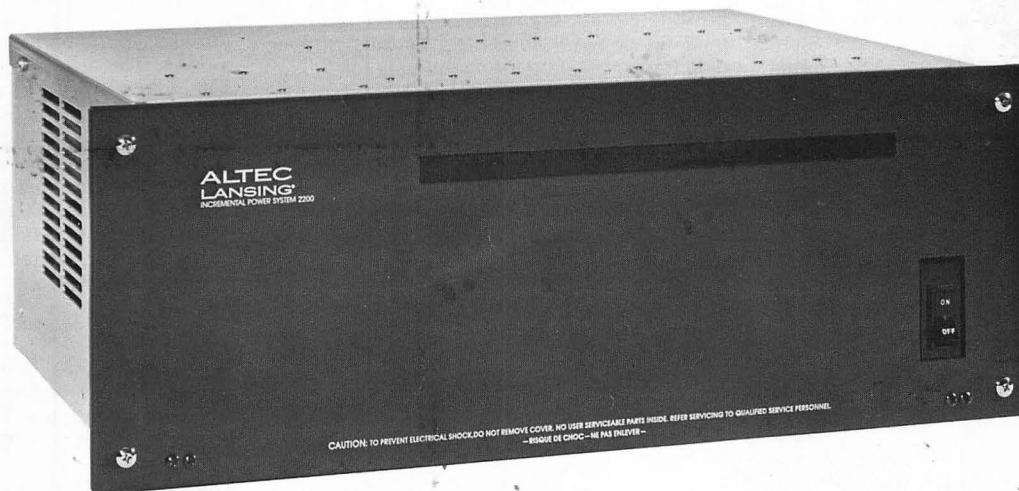

INTRODUCTION TO THE INCREMENTAL POWER SYSTEM

The ALTEC Incremental Power System consists of a main frame with plug-in modules. The rackmount main frame accepts modular input, crossover, driver, and up to eight 75-watt power amplifier cards.

The ALTEC Incremental Power System can:

- Control high, mid, and low frequency loudspeakers with separate power amplifiers.
- Connect far, middle, and near-throw horns to separate power amplifiers while providing separate level controls.
- Power up to four separate balanced 70-volt systems from a single main frame.
- Power extremely complex sound systems by combining the abilities of two or more Incremental Power Systems.

Power amplifier modules may be combined in increments of 75 watts to meet most conceivable audio applications. Parallel modes may drive high power, low impedance loads. Bridged modes may drive balanced 70-volt lines. A parallel-bridge mode may drive high power balanced 70-volt lines or other loads.

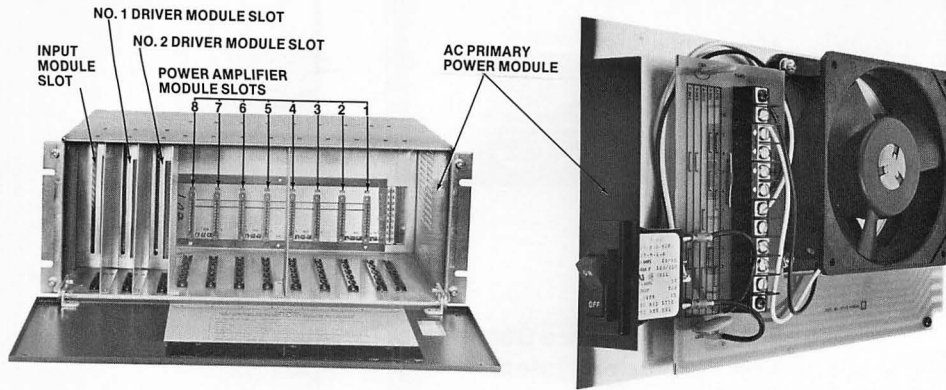

Figure 1. Main Frame and Position Assignments of Card Modules

MAIN FRAME

The main frame accepts one primary power (ac) module, one input module, up to two driver or crossover driver modules, and up to eight power amplifier modules. Each plug-in module is inserted into the appropriate connector within the main frame, according to functional position as shown in Figure 1. A hinged panel covers the module positions after installation and adjustment.

All input/output connections are located on the rear panel of the main frame. Four XLR-3 type female receptacles connect balanced signals to the selected input module. Eight 1/4" phone jacks connect up to four separate unbalanced input signals. Four special input/output stereo 1/4" phone jacks (J213, J214, J215, and J216) connect up to eight unbalanced signals directly to the driver modules. Separate output connections are provided for each power amplifier module position.

When balanced input signals are fed to the appropriate XLR-3 type connectors, output signals may be derived at the UNBAL phone jack connectors. The eight (UNBAL) phone jacks adjacent to the XLR-3 connectors may

become *unbalanced outputs*, deriving signals from transformer secondaries of the Model 2221 Input Card Module. The four special input/output jacks may become special *outputs*, deriving signals from the high, mid, and low frequency outputs of the Model 2251 Crossover Driver Card Module. This capability of special signal routing is readily indicated from study of the Modular Block Diagram.

As shipped from the factory, each main frame is equipped with an ac primary power module, installed as in Figure 1. The module is equipped with an ON-OFF ac power switch (circuit breaker type) with built-in pilot lamp. A terminal strip permits strapping the power transformer primary for 100V, 120V, 200V, 220V, or 240V at 50/60 Hz; as shipped from the factory, straps are installed for 120 Vac. A fan is incorporated in the module for forced-air cooling of power amplifier modules.

INPUT MODULES

The main frame of the Incremental Power System has four primary input connectors (XLR-3 type) which accept balanced inputs.

One input module card may be inserted in the main frame to process four primary inputs. These four inputs may be balanced or unbalanced by using the Model 2221 (transformer isolated) Input Card Module. The four inputs may be unbalanced by using the Model 2220 (transformerless) Input Card Module. Each input card module has four adjustable attenuators to set levels separately for each input. Figure 2 illustrates each type of input card module.

If inputs to the main frame are unbalanced, it is not always necessary to use an input card module, because the Model 2250 and 2252 Driver Modules have attenuators to adjust signal levels. However, the Model 2251 Crossover Driver Module *requires* use of either Model 2220 or Model 2221 Input Card Module, because this driver input cannot access special input/output jacks J213, J214, J215, or J216.

DRIVER MODULES

The driver modules feed the inputs to the power amplifier modules for the desired combinations of output for low, mid, high, or full frequency ranges. One or two driver modules, of any type and in any combination, may be inserted in the main frame to process the inputs. A switching matrix is built into each driver module for the power amplifier modules to be operated in parallel, bridged, parallel-bridged, or independent modes. The driver modules are equipped with two or more driver-amplifier circuits, with the input of each circuit independently adjustable. Driver modules with the (SA) suffix are adjustable with step attenuators in increments of -1 dB, to a maximum of -63 dB. Modules without the (SA) suffix are continuously adjustable to a maximum attenuation of at least -60 dB. Figure 3 illustrates the various types of driver card modules.

The Model 2250 Driver Card Module includes two driver-amplifier circuits, an 8-channel input switching matrix, and an 8-channel output switching matrix.

The Model 2252 Driver Card Module includes four driver-amplifier circuits, an 8-channel input switching matrix, and an 8-channel output switching matrix.

The Model 2251 Crossover Driver Card Module is specially designed to provide two-way or three-way electronic crossover. The module includes three driver-amplifier circuits and an 8-channel output switching matrix. Selectable frequencies are 625 Hz, 800 Hz, 1250 Hz, and 1600 Hz for low to mid frequency; 3150 Hz, 4000 Hz, 5000 Hz, and 8000 Hz, for mid to high frequency. Slope rate is fixed at 12 dB per octave. The crossover driver module can drive the power amplifier modules directly, or feed into another driver module to create different signal levels from one crossover driver output. One or two crossover driver modules may be inserted in the main frame for a monaural or stereo bi-amplified or tri-amplified system. Input to the Model 2251 Driver must come from Model 2220 or 2221 Input Card Module via channel 1 (left-hand driver module slot) or channel 3 (right-hand driver module slot).

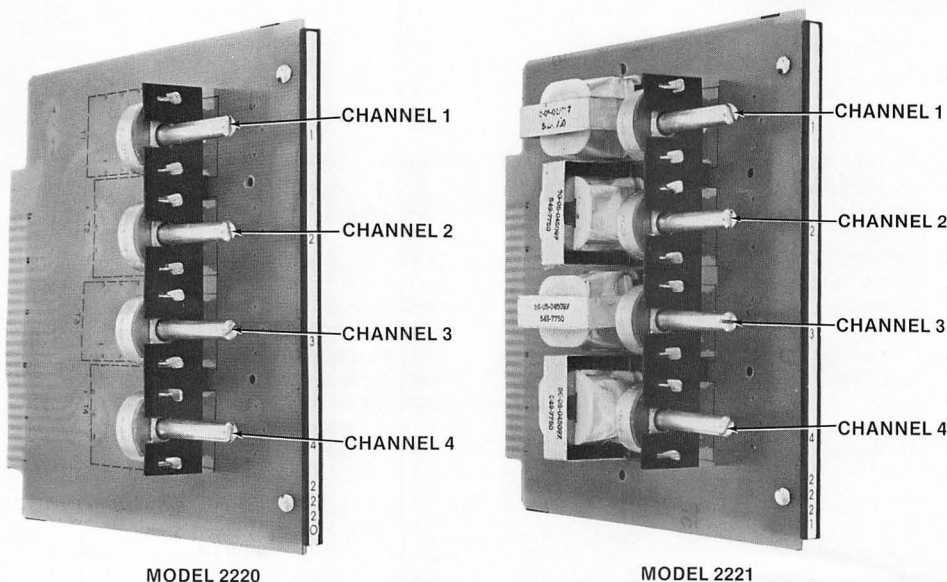
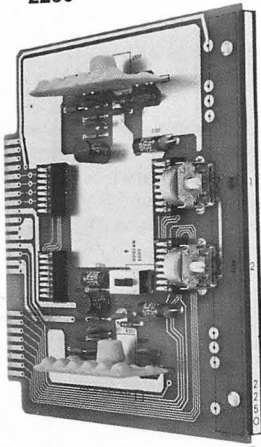
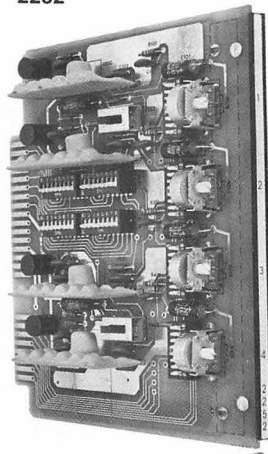

Figure 2. Model 2221 and 2220 Input Card Modules

2250



2252



2251

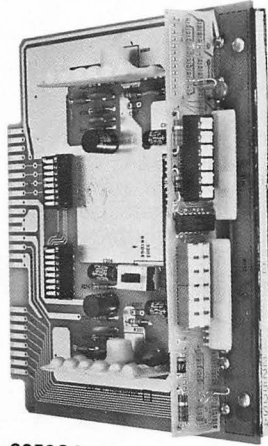
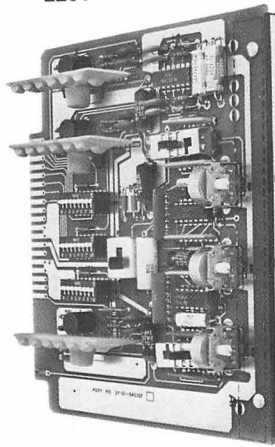

2250SA

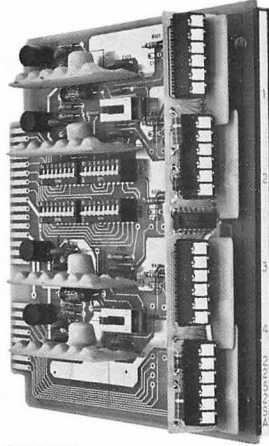

2252SA

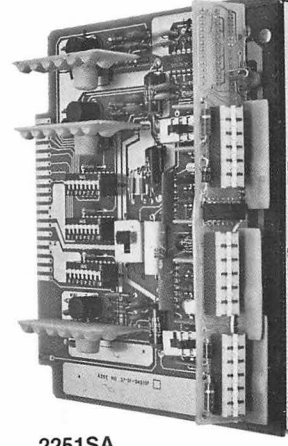

2251SA

Figure 3. Driver Card Modules for the Incremental Power System

POWER AMPLIFIER MODULES

Up to eight Model 2275 Power Amplifier Modules may be inserted in the main frame for the desired power rating and power configuration. The power amplifier modules are rated at 75 watts each and may be combined in 75-watt increments for up to 600 watts output power from each main frame system. Power output level and power distribution configurations may be selected to meet most audio applications. Figure 4 illustrates the Model 2275 Power Amplifier Card Module.

Typical operating configurations of the Model 2275 Power Amplifier Module include:

- Independent mode for separate loudspeaker loads.
- Parallel mode to increase output power in increments of 75 watts for higher power, low impedance loads.
- Bridged mode to drive balanced 70-volt lines. Two power amplifier modules, driven out-of-phase to each other, have the loudspeaker load connected to the 'hot' terminals of the two modules. Power available is 150 watts.
- Parallel-bridged mode to drive higher power balanced 70-volt lines, or other high power loads. Two sets of parallel power amplifier modules may be bridged

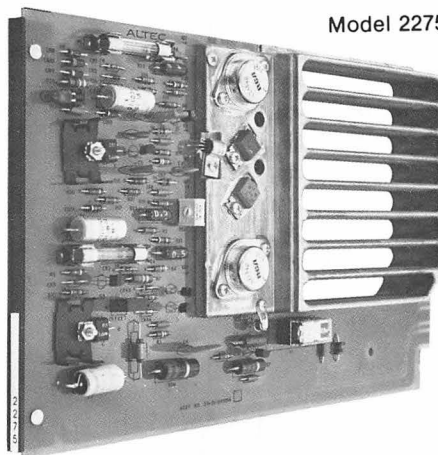

Model 2275

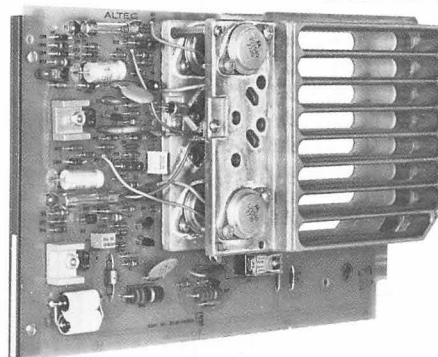

Model 2276

Figure 4. Model Power Amplifier Card Modules

to obtain maximum output power ratings of 300 watts (2 sets of 2 modules), 450 watts (2 sets of 3 modules), or 600 watts (2 sets of 4 modules).

Up to 4 Model 2276 Model 2276 Power Amplifier Modules may be inserted in the main frame for the desired power rating and power configuration. Each module is rated at 150 watts. The modules may be combined in 150-watt increments for up to 600 watts output power from each main system. Operating configurations are similar to the model 2275 Power Amplifier Module, except for the power rating of 150 watts per module. Figure 4 illustrates the Model 2276 Power Amplifier Card Module.

Typical operating configurations of the Model 2276 Power Amplifier Module include:

- Independent mode for separate loudspeaker loads.
- Parallel mode to increase output power in increments of 150 watts for higher power, low impedance loads. Power available is 300, 450, or 600 watts.
- Bridged mode to drive balanced 70-volt lines. Two power amplifier modules, driven out of phase to each other, have the loudspeaker load connected to the 'hot' terminals of the two modules. Power available is 300 watts.
- Parallel-bridged mode to drive higher power, balanced 70-volt lines, or other high power loads. Two sets of parallel power amplifier modules may be bridged to obtain an output power of 600 watts.

If fewer than four Model 2276 modules are used in a main frame system, Model 2275 Power Amplifier Modules may be installed in remaining power module positions. The Models 2275 and 2276 modules may be used in independent modes, or intermixed in various combinations of parallel, bridged, or parallel-bridged modes.

As shipped from the factory, the main frame and each power amplifier module operate into a load impedance of 16 ohms. By selecting other taps on the ac power transformer of the main frame and removing two jumper leads of each power amplifier module, the main frame system can operate into a load impedance of 8 ohms. For parallel and bridged configurations, specific loudspeaker load requirements are discussed within the installation portion of the instructions.

INSTALLATION

VENTILATION

The Incremental Power System must be adequately ventilated to prevent excessive temperature rise. Maximum rated ambient operating temperature is 55°C (131°F).

CAUTION

Do not block the side ventilation apertures on either side of the main frame. Allow at least 2" on each side of the main frame to assure adequate ventilation. Do not operate within a completely closed, unventilated housing.

RACK MOUNTING

The main frame of the Incremental Power System is designed for installation in a standard 19-inch equipment rack. Vertical space required for mounting is 7" for each main frame.

1. Remove four screws that secure the front panel. Open and lower front panel as shown in Figure 5.
2. Install main frame in equipment rack, using appropriate four screws supplied.

CAUTION

While positioning the main frame in the equipment rack, *do not* use the large filter capacitors as handles. Lift or handle only by the chassis and power transformer.

3. After installing all modules, close front panel and secure with four screws previously removed.

SHELF MOUNTING

In handling the main frame for shelf mounting, be sure to observe the CAUTION of Step 2, in RACK MOUNTING. Four rubber feet with attaching screws are supplied with each main frame. Position the main frame on one side and attach the feet to the underside of the chassis.

MODULE INSTALLATION

The input, driver, and power modules are installed in the main frame according to the functional locations of Figure 5. The ac primary power module is installed in each main frame shipped from the factory. Remaining modules must be unpacked and installed in the main frame as follows:

1. Remove four screws that secure the front panel. Open and lower front panel as shown in Figure 5.

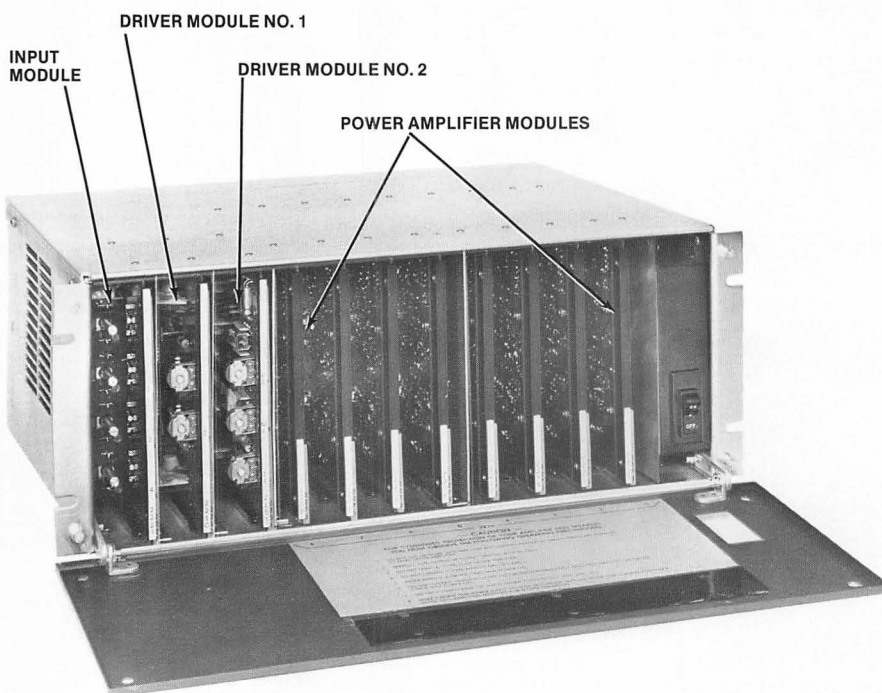

Figure 5. Installation of Card Modules in Main Frame

2. Guide channels align and support each card module, which plugs into a connector at the rear of the main frame. Insert each module so that the card edges fit into the flanged portion of the top and bottom guides. Gently push the card module into the guides until it engages the rear connector. Press firmly until fully seated.

CAUTION

Do not insert or remove any *driver* card module from the main frame when primary ac power is applied.

3. After all modules are installed (and all driver module switch matrices are set up correctly), close the front panel and secure with four screws previously removed.

NOTE

When fewer than 8 Model 2275 Power Amplifier Modules are installed in the main frame, install modules in slots nearest the fan for optimum cooling.

ELECTRICAL

120 Volt, 50/60 Hz Power Connections

Equipment is supplied for domestic use with the power transformer primary strapped for 120 volts. The power input rating appears at the rear of the main frame chassis, adjacent to the power cord (see Figure 8). Verify that line voltage is in accordance with the voltage rating *before* connecting the Incremental Power System to line power.

Alternate 50/60 Hz Primary Power Connections

The Incremental Power System may operate from an ac primary power source having 100V, 120V, 200V, 220V, or 240V at 50/60 Hz. As shipped from the factory, the power

transformer primary is strapped for 120 volts. The voltage rating is at the rear of the main frame chassis, adjacent to the power cord.

Qualified service personnel may change the transformer primary straps for the desired operating voltage. The primary power straps are located at terminal board TB301, within the ac primary power module. To change the straps:

1. Unplug ac cable from ac power source. Remove ac primary power module from main frame. Locate terminal board TB301 on the card module (Figure 6).
2. Remove three 120-volt straps from terminals 2 to 3, 6 to 7, and 8 to 9.
3. See Figure 6 to connect necessary straps to proper terminals for the desired operating voltage.
4. From accessory kit supplied with main frame, select corresponding voltage rating sticker. Peel sticker from backing and affix new voltage rating over 120V designation at rear of main frame.
5. Install ac primary power module in main frame.

Conversion for 8-Ohm Load Impedance

All Incremental Power Systems are shipped from the factory with internal wiring connected for 16 ohms load impedance. The systems may be altered by qualified personnel for 8 ohms load impedance. Appropriate alterations must be made at the main frame *and every Model 2275 Power Amplifier Module used in the modified main frame*. To accomplish the 8-ohm conversion,

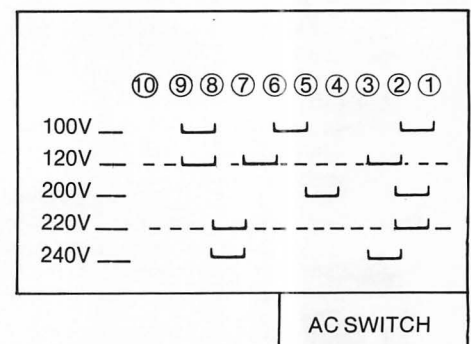
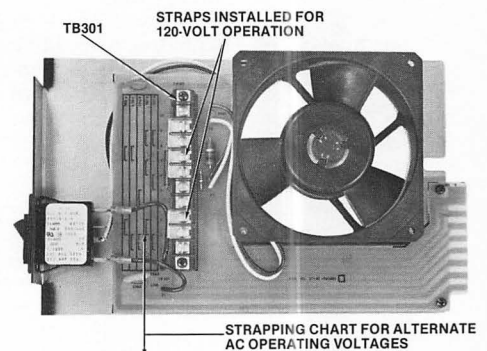

Figure 6. AC Primary Power Module and Alternate 50/60 Hz Power Connections

1. Unplug ac cable from ac power source.
2. Remove screws that secure top cover to main frame. Lift front edge of cover and pull cover forward to clear rear lip from chassis. Lift cover off.
3. Locate terminal board TB101 (Figure 7). Disconnect top lead from terminal 1 and reconnect to terminal 2. Disconnect top lead from terminal 4 and reconnect to terminal 3. This wiring change modifies the main frame to operate at 8 ohms load impedance.
4. For each power amplifier module used with a modified main frame, locate jumpers J8A and J8B on component side of module (Figure 7). Remove these two jumpers to modify each power amplifier module to operate at 8 ohms rated load impedance.

CAUTION

The 8-ohm modified power amplifier module may *not* be used in a main frame not modified as in Step 3. To avoid possible mixup, clearly tag or mark the 8-ohm modified modules "for 8-ohm operation only". Similarly, the modified main frame should be tagged for "8-ohm operation only".

5. Install top cover of main frame and secure with screws previously removed (Step 2). Note that all card modules may require removal and re-installation after top cover is secured, to assure proper alignment in card guide channels.
6. Install modified power amplifier modules in main frame.

SETUP AND OPERATION

MODULAR BLOCK DIAGRAM

The Modular Block Diagram Kit consists of a simplified Main Frame Wiring Diagram (42-02-045233) with designations for connecting power amplifier modules. To complete the Main Frame Wiring Diagram, selected module diagrams are taken from the

Module Diagram Sheets (42-02-045232) and affixed to appropriate spaces within the Main Frame Wiring Diagram. The Main Frame Wiring Diagram then becomes the Modular Block Diagram. Switch and cable connections are then drawn on the Modular Block Diagram to complete a drawing of the system configuration. The finished Incremental Power System block diagram may be copied on any standard blue-line machine or other large-format copier.

To use the Modular Block Diagram Kit in an orderly way,

1. Choose input, driver, and power amplifier modules as needed from the Module Diagram Sheets. Remove the module diagrams from the sheets and carefully affix each module diagram to the appropriate space on the Main Frame Wiring Diagram. Pressure-sensitive adhesive on the back of the module diagrams will hold them securely. Do not allow the adhesive to touch the Main Frame Wiring Diagram until the module diagram is oriented accurately.
2. Indicate switch closures on the driver matrices by drawing a line between switch contacts, or by circling the entire switch, or both. As necessary, refer to setup procedures for the appropriate driver module.
3. Draw simplified loudspeaker connection diagrams to the right-hand side of the power amplifier modules. As necessary, refer to OUTPUT CONNECTIONS in this manual.
4. Make as many copies of the finished Modular Block Diagram as required.

Finished examples of the Modular Block Diagram are illustrated in Figures 19 through 23. Additional Modular Block Diagram Kits may be ordered from the ALTEC Literature Department. For each kit desired, ask for one copy of the Main Frame Wiring Diagram, AL-1212 (42-02-045233) and one copy of the Module Diagram Sheets, AL-1213 (42-02-045232)

INPUT CONNECTIONS

All input connections to preamplifiers or other signal processing equipment are made at the rear panel of the main frame (Figure 8). Connections should be made with two-conductor, twisted-pair shielded cable such as Belden 8450 or 8451.

For balanced input at the CH-1 through CH-4 receptacles, the Model 2221 (transformer isolated) Input Card Module must be installed in the input module slot of the main frame. For unbalanced input at the UNBAL jacks, either the Model 2220 (transformerless) Input Card Module or the Model 2221 Input Card Module may be installed.

If electronic crossover is to be incorporated, the Model 2251 Crossover Driver Card Module must be installed in the appropriate locations. Inputs for electronic crossover are dedicated at CH-1 and CH-3 BAL or UNBAL INPUT. The CH-1 connector requires a crossover driver module to be installed in the main frame at the #1 (left) driver module position; the CH-3 connector requires a crossover driver module to be installed in #2 (right) driver module slot.

Always be sure to use the correct plug in the main frame connectors (Figure 8). The J213 thru J216 receptacles *require* use of stereo phone jacks.

CAUTION

Standard phone plugs (tip and sleeve) will short-circuit internal wiring when inserted in jacks J213, J214, J215, or J216.

Unbalanced Inputs

For unbalanced input signals connected to the UNBAL INPUT jacks of Channels CH-1 thru CH-4, install the Model 2220 Unbalanced Input Card Module in the input module slot of the main frame. Each of the four channels has two UNBAL jacks wired in parallel; this makes available a convenient signal to feed a second Incremental Power System, a Model 9440 Power Amplifier, or other alternate unit.

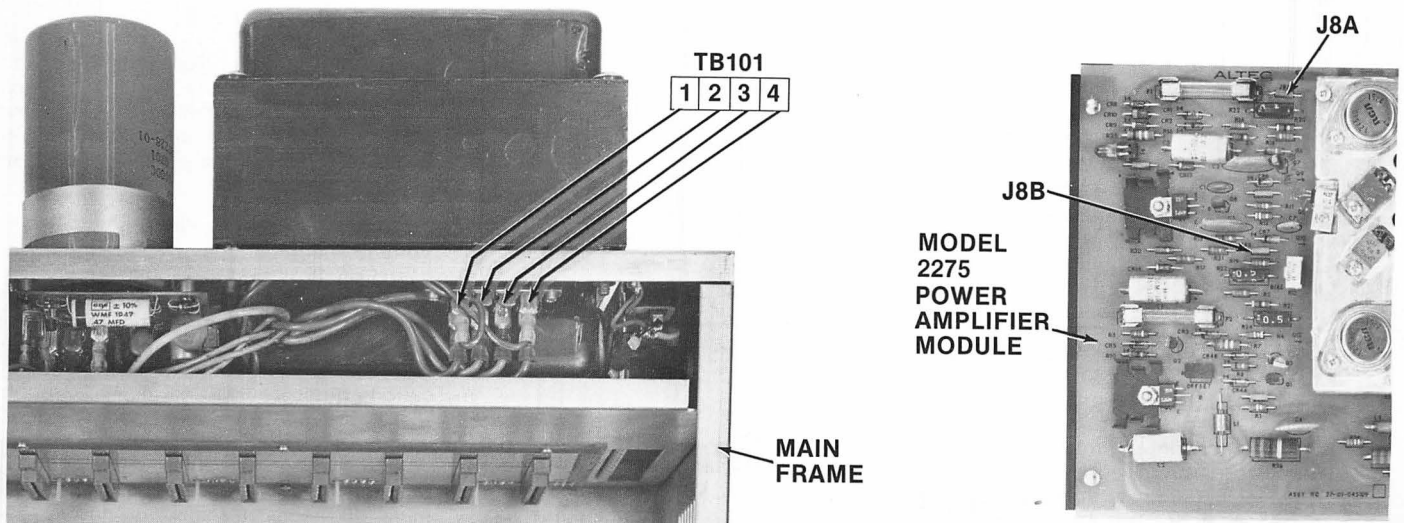
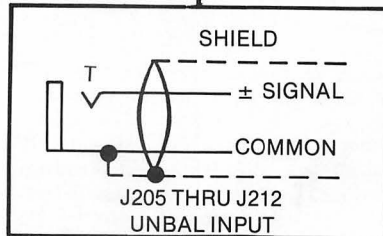
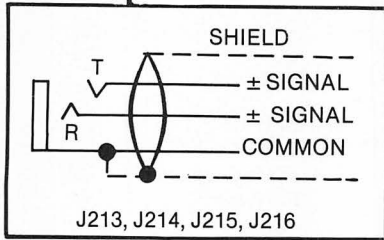
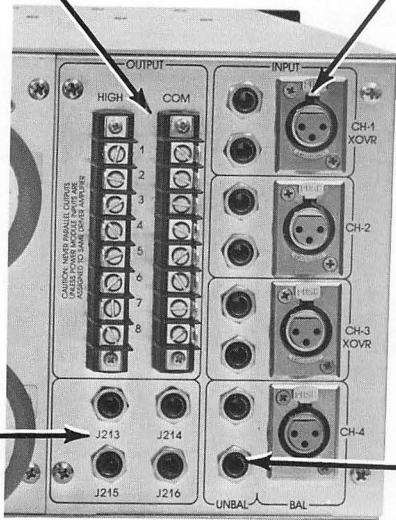
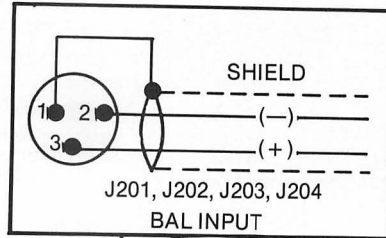
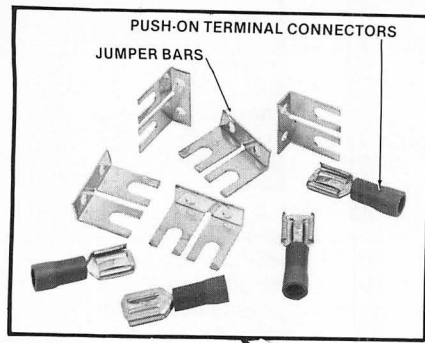

Figure 7. Modification of Main Frame and Power Amplifier Modules for 8-Ohm Operation



NOTE

Although a total of 8 unbalanced inputs may be applied to special input/output jacks J213, J214, J215, and J216, this does *not* imply that these 8 inputs *plus* a number of additional inputs may be applied through the input card modules. Each Incremental Power System may process a maximum of 8 channels through separate paths having independent level controls.

Balanced Inputs

For balanced input signals, install the Model 2221 Balanced Input Card Module in the input module slot of the main frame. Connect up to four balanced input signal cables to the BAL INPUT connectors of channels CH-1, CH-2, CH-3, and CH-4. Wiring of the XLR-3 type balanced connector is shown in Figure 8.

The four pairs of UNBAL INPUT phone jacks, adjacent to the BAL INPUT connectors, receive signals from the secondary of the module input transformers. These phone jacks may be used to feed a second Incremental Power System, a Model 9440 Power Amplifier, or other device.

Balanced inputs may *not* be connected to special input/output jacks J213, J214, J215, or J216. These special jacks are intended for use *only* with unbalanced connections. However, balanced signals from the Model 2221 Input Module may be routed through a driver input matrix to appear as an unbalanced signal at these special jacks. A study of the modular block diagram will indicate a variety of possible configurations.

OUTPUT CONNECTIONS (MODEL 2275 ONLY)

CAUTION

This section applies *only* where the Model 2275 Power Amplifier Modules are used. Refer to technical publication 42-02-045362, Model 2276 Power Amplifier Module, for appropriate output connections regarding the Model 2276.

Output connections from the power amplifier modules are made at the OUTPUT HIGH and COM terminals on the rear panel of the main frame. Figure 9 illustrates various output configurations for independent, parallel, bridged, and parallel-bridged modes of operation. Note that the voltage specifications given in Figure 9 enable calculation of power delivered to a loudspeaker system where loudspeaker load impedance is higher than the rated load impedance listed, where:

$Power (V \times A) = \frac{(Voltage)^2}{Impedance}$
Voltage specifications given in Figure 9 are based on 16 ohms load impedance for the Incremental Power System. If a system is modified for a load impedance of 8 ohms, impedance values of Figure 9 must be halved. At the same time, the 70-volt specifications must be changed to 49 volts, and the 35-volt specifications changed to 24.5 volts.

Use the Modular Block Diagram to determine all necessary input/output connections, and to determine set-up of all driver switching matrices for the desired output configuration.

1	CH-1 thru CH-4 BAL Receptacles	Connect balanced input signals to channels 1 through 4, respectively. Channels 1 and 3 are dedicated to the electronic crossover option. XLR-type receptacles.
2	UNBAL Phone Jacks	Connect unbalanced signals to channels 1 through 4. One pair of jacks are wired in parallel for each channel. Standard 1/4" tip and sleeve phone jacks.
3	J213, J214, J215 and J216 Special Input/Output Jacks	Connect eight unbalanced input signals directly to the driver modules. Tip and ring carry separate input signals. Sleeve is common. Do not use standard phone plugs (tip and sleeve), as this will short-circuit internal wiring. Standard 1/4" stereo (ring, tip and sleeve) phone jacks.
4	OUTPUT Terminals	Connect outputs of power modules to the loudspeaker system. Eight sets of HIGH and COM 1/4" push-on type terminal connectors correspond to eight power amplifier module positions in the main frame.

Figure 8. Input and Output Connections at Main Frame

Up to eight unbalanced inputs may be connected to special input/output jacks J213, J214, J215, and J216, using *stereo* (tip, ring, and sleeve) phone plugs. Two inputs connect to each jack, with tip and ring carrying separate signals with respect to the common sleeve. These input signals are applied

directly to the driver modules and may be controlled by the attenuators on the Model 2250 or 2252 Driver Modules. Since these special inputs bypass the input module, it is not necessary to install an input module if no other inputs are connected to the main frame.

Independent Operation			Bridged Operation		
Rated Power Output	Rated Load Impedance	Rated RMS Sine-wave Voltage Output	Rated Power Output	Rated Load Impedance	Rated RMS Sine-wave Voltage Output
75 watts	16 ohms	35 volts	150 watts	32 ohms	70 volts

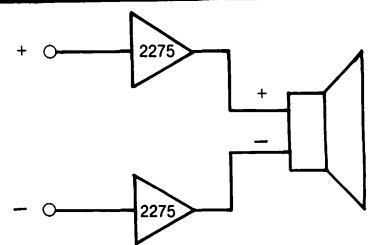

Parallel Operation	Number of Parallel Model 2275 Power Amplifiers							
	1	2	3	4	5	6	7	8
Rated Power Output	75 watts	150 watts	225 watts	300 watts	375 watts	450 watts	525 watts	600 watts
Rated Load Impedance	16 ohms	8 ohms	5.3 ohms	4 ohms	3.2 ohms	2.7 ohms	2.3 ohms	2 ohms
Rated RMS Sine-Wave Voltage Output	35 volts	35 volts	35 volts	35 volts	35 volts	35 volts	35 volts	35 volts

Parallel/Bridged Operation

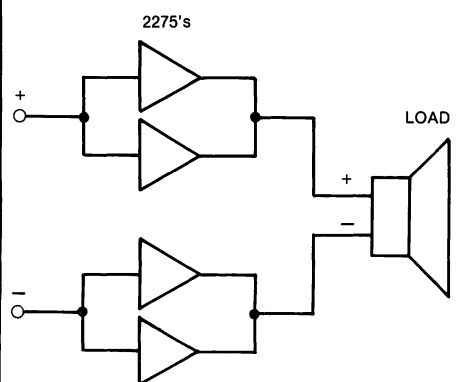

Rated Power Output	Rated Load Impedance	Rated RMS Sine-Wave Voltage Output
300 watts	16 ohms	70 volts

2 SETS OF (2) 2275's (4 TOTAL)

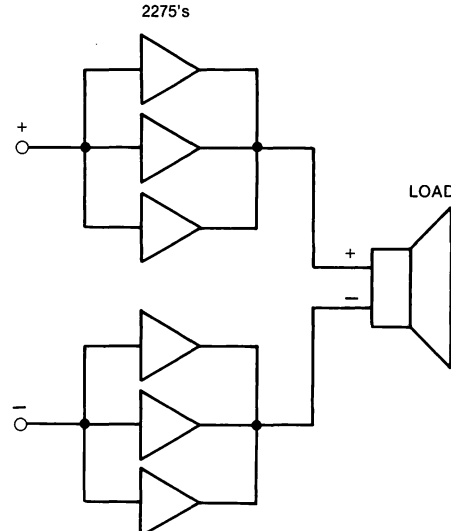

Rated Power Output	Rated Load Impedance	Rated RMS Sine-Wave Voltage Output
450 watts	10 $\frac{2}{3}$ ohms	70 volts

2 SETS OF (3) 2275's (6 TOTAL)

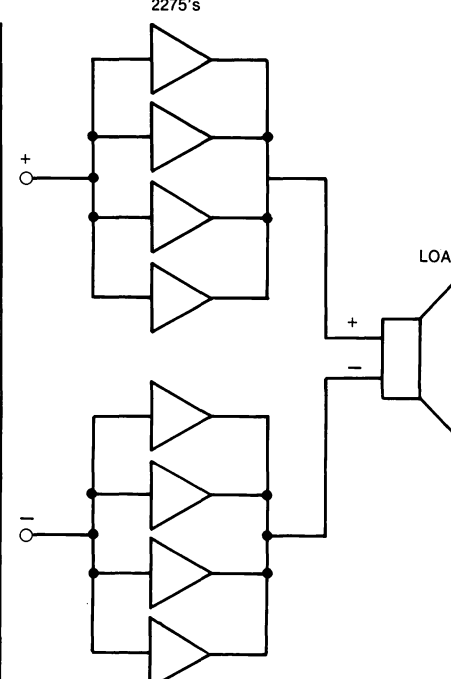

Rated Power Output	Rated Load Impedance	Rated RMS Sine-Wave Voltage Output
600 watts	8 ohms	70 volts

2 SETS OF (4) 2275's (8 TOTAL)

Figure 9. Power Output, Impedance, and Voltage Output for Various Combinations of Model 2275 Power Amplifier Modules. Voltage specifications are based on 16 ohms load impedance. For systems modified for 8 ohms load impedance, change listed impedance values to one-half value; change 70-volt listings to 49 volts, and 35-volt listings to 24.5 volts. For Model 2276 Power Amplifier Modules, refer to separate technical publication (42-02-045362).

70-Volt Loudspeaker Distribution System

For 70-volt loudspeaker distribution systems, connect the HIGH OUTPUT terminals as described in 'Bridged Operation', and in 'Parallel/Bridged Operation'. These configurations are based on 16 ohms load impedance for the main frame and for the Model 2275 Power Amplifier Modules.

25-Volt Loudspeaker Distribution Systems

For 25-volt loudspeaker distribution systems, modify the main frame, and each Model 2275 Power Amplifier Module to be used therein, for 8-ohm load impedance;

refer to 'Conversion for 8-Ohm Load Impedance. Connect HIGH and COM OUTPUT Terminals as described in 'Independent Operation' and in 'Parallel Operation'.

It is possible to use 16-ohm power amplifier modules in a main frame modified for 8-ohm operation. However, at 25 volts output, maximum power available for each power amplifier module is 37.5 watts per module (into 16 ohms).

Independent Operation

To operate one or more power amplifier modules independently, each module must

receive a separate input signal and drive a separate loudspeaker load (Figure 10). Input signals must be routed through a driver module. No input signals may be routed from an input module directly to a power amplifier module, or from special input/output jacks J213, J214, J215, and J216 directly to a power amplifier module.

Connect the loudspeaker load to the appropriate terminals of the HIGH (TB201) and COM (TB202) OUTPUT terminal boards. Rated load impedance for a single power amplifier module in the independent mode is 16 ohms (or 8 ohms in modified version). Rated power output is 75 watts.

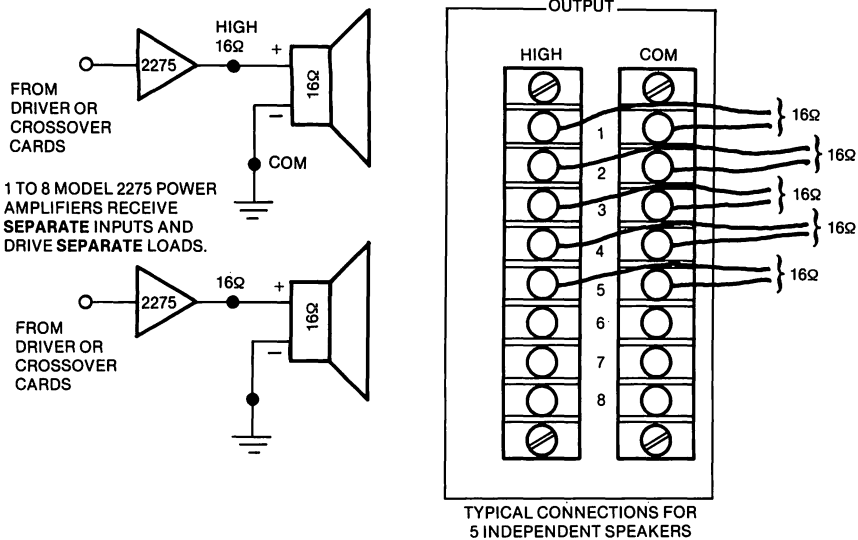

Figure 10. Typical Independent Mode of Operation

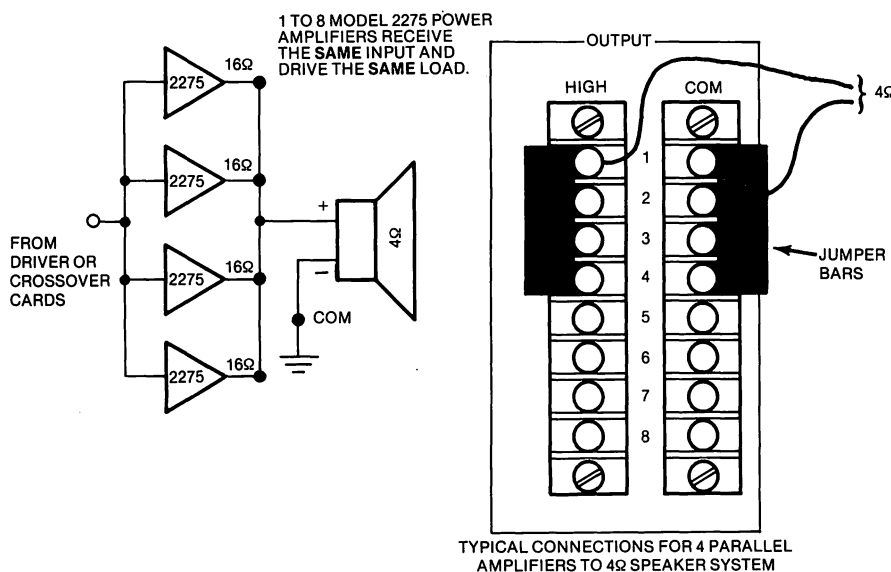

Figure 11. Typical Parallel Mode of Operation

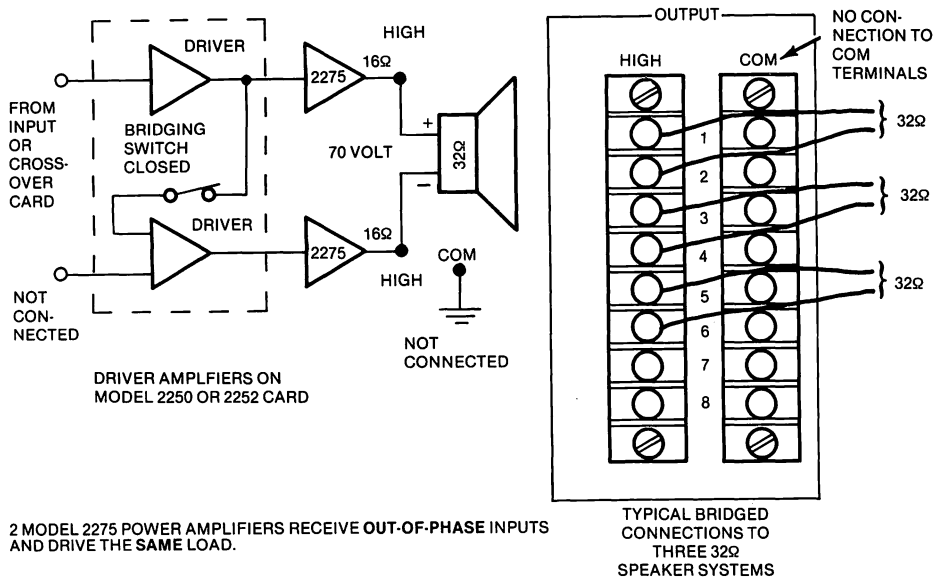

Figure 12. Typical Bridged Mode of Operation

Parallel Operation

Up to eight power amplifier modules may be paralleled. Parallel power amplifier modules *must* receive one (common) input signal and drive one (common) loudspeaker load (Figure 11).

Route a single input signal to the power amplifier modules by closing the correct switches of the driver module switching matrix. Parallel outputs of the desired number of power amplifier modules by connecting jumper bars (supplied with the accessory kit) to the HIGH and the COM terminals.

CAUTION

If the outputs of two or more power amplifier modules are paralleled, the inputs to the same modules also must be paralleled by closing the proper switches of the driver output switching matrix. Mismatched (non-parallel) or unassigned input paths to power amplifier modules having paralleled outputs may cause fuses to blow within the modules.

Connect the loudspeaker load to the paralleled HIGH terminals and paralleled COM terminals.

Rated power output in the parallel mode is 75 watts x (number of parallel power amplifier modules). Rated load impedance is 16 ohms (or 8 ohms in modified version), divided by the number of parallel power amplifier modules.

Bridged Operation

Bridged operation requires that 'out-of-phase' signals must be applied to the inputs of the two power amplifier modules to be used in this mode. The input to the first module must be inverted and applied to the second module. See Figure 12. This inversion may be accomplished with either the Model 2250 or 2252 Driver Module. The Model 2251 Crossover Driver Module may *not* be used to accomplish this inversion.

Route the input signal to the first driver amplifier circuit by closing the appropriate switch of the driver input switching matrix. Close bridging switch S202; this applies the input signal to the 'inverting input' of the second driver amplifier circuit. *Do not* assign any input signal to the normal (non-inverting) input of the second driver amplifier circuit with the driver input switching matrix; in addition, turn the input attenuator of the second driver amplifier circuit fully counterclockwise to minimum level; for SA type driver modules, set all rocker switches to the right for maximum attenuation of 63 dB. Route the output of the first driver amplifier circuit to the input of one power amplifier module by closing the appropriate switch of the driver output switching matrix. Route the output of the second driver amplifier circuit to the input of another power amplifier module by closing the appropriate matrix switch. Connect the loudspeaker load to the HIGH OUTPUT terminals of the two power amplifier modules. *Do not* connect the loudspeaker load to the COM terminals.

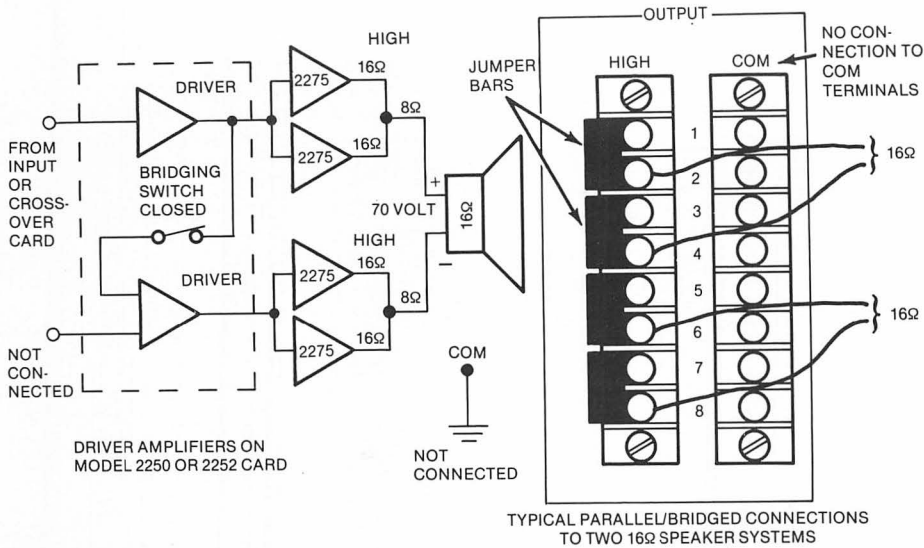

2 SETS OF UP TO 4 MODEL 2275 POWER AMPLIFIERS PER SET RECEIVE "OUT OF PHASE" INPUTS AND DRIVE THE SAME LOAD.

Figure 13. Typical Parallel/Bridged Mode of Operation

Rated output power from two bridged power amplifier modules is 150 watts. Rated load impedance is 32 ohms (or 16 ohms in modified version). The bridged output is a 70-volt (or 49-volt in modified version) balanced (non-floating) output which may drive 70-volt or 49-volt commercial sound loud-speaker lines.

Parallel/Bridged Operation

The parallel/bridged mode produces a 70-volt (or 49-volt in modified version) balanced output at a higher power level than the simple bridged mode.

First parallel two identical sets of power amplifier modules as described in *Parallel Operation*. Each set must contain the same number of paralleled power amplifier modules (two, three, or four modules per set).

Then, bridge the two sets of paralleled power amplifier modules as described in *Bridged Operation*, as if each set were a single module (Figure 13).

Always bridge two sets of paralleled power amplifier modules; *do not parallel two sets of bridged power amplifier modules*.

Rated power output for the parallel/bridged mode is equal to 75 watts times the number of power amplifier modules connected into the configuration. Rated load impedance is 64 ohms (or 32 ohms in modified version) divided by the number of power amplifier modules in the configuration. The parallel/bridged output is a 70-volt (or 49-volt in modified version) balanced (non-floating) output which can drive high power 70-volt or 49-volt commercial sound loudspeaker lines or other high power loads.

SETUP OF DRIVER CARD MODULES

Input Switching Matrix

An input switching matrix is provided for the Model 2250 and 2252 Driver Card Modules. The Model 2251 Crossover Driver contains no input switching matrix. Incoming signals to the input switching matrix arrive from an input card module, a Model 2251 Crossover Driver Module, or special input/output jacks J213, J214, J215, or J216.

Input matrix switches of the Model 2250 Driver are designated S103 and S203; for the Model 2252 Driver, designations are S103, S203, S303, and S403. Use the input matrix switches to assign an input to one of the driver amplifier circuits on the driver card module. For example, to assign an input from line 6 to the #1 driver amplifier circuit, close the #6 switch of S103 in the driver input switching matrix. To assign an input from line 3 to the #2 driver amplifier circuit, close the #3 switch of S203. Input switching matrices are identical for SA type modules.

Always leave all unused (unassigned) input matrix switches OFF (open) to avoid possible misrouting of input signals.

Output Switching Matrix

An output switching matrix is provided on all driver card modules to assign driver amplifier circuit outputs to the appropriate power amplifier modules. For example, to assign the output of the #4 driver amplifier circuit (Model 2252 Driver Module) to the input of power amplifier module #2, close the #2 switch of S401 in the driver output switching matrix. To assign the output of driver amplifier circuit #3 to the inputs of power amplifier modules #5 and #6, close the #5 and #6 switches of S301. Output switching matrices are identical for SA type modules.

Always leave all unused (unassigned) output matrix switches OFF (open) to avoid

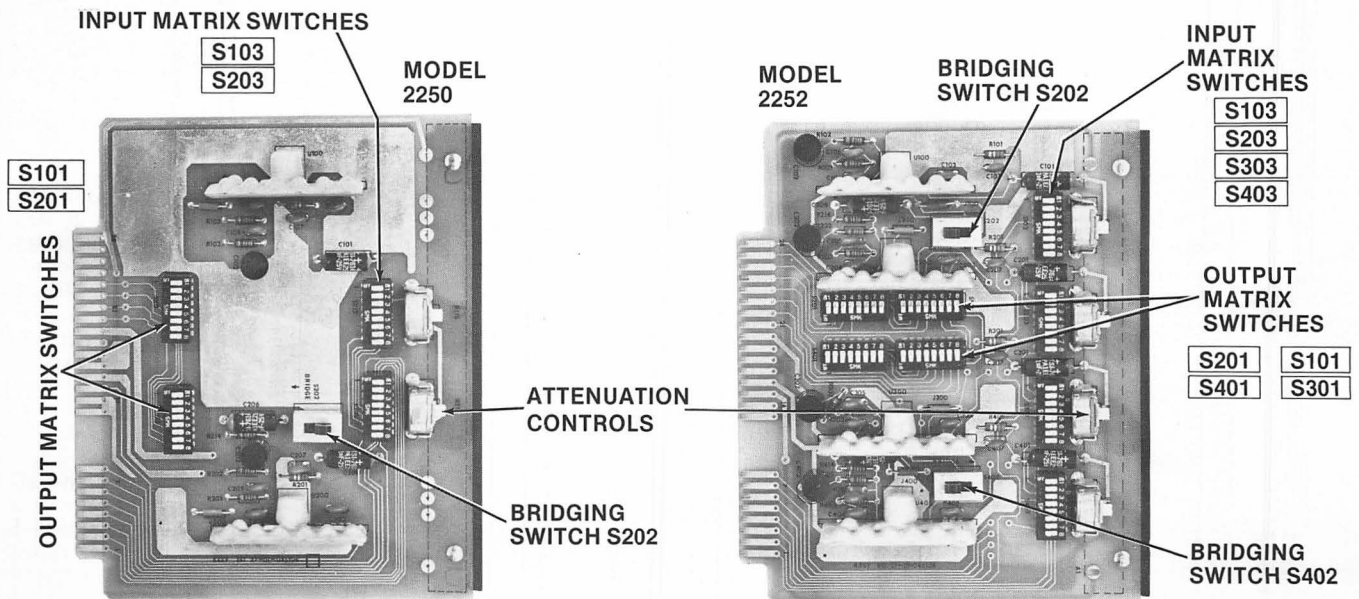

Figure 14. Bridging and Matrix Switching for Model 2250 and 2252 Driver Modules

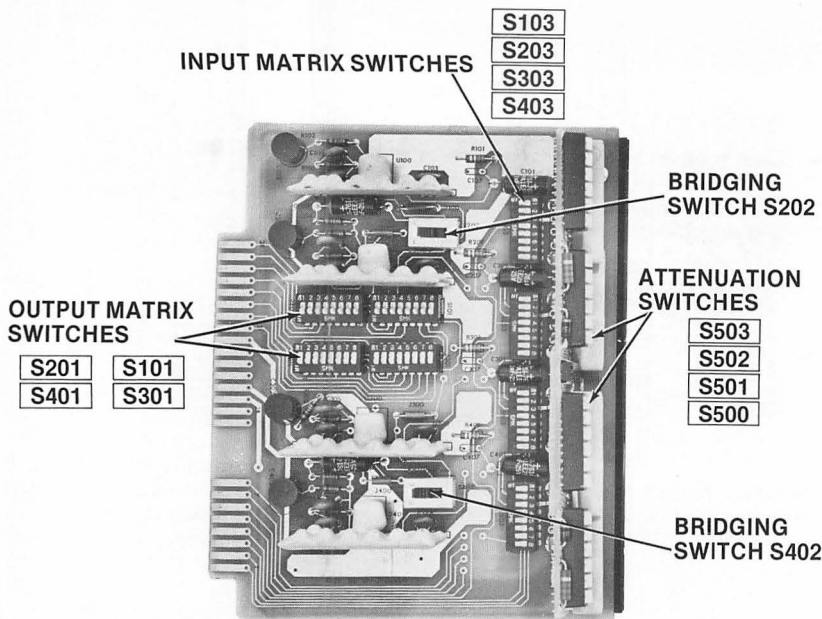

Figure 15. Typical SA Type Driver Module (Model 2252 SA Shown)

possible misrouting of driver output signals.

Bridging Switches

Bridging switches are provided on the Models 2250 and 2252 Driver Modules to bridge outputs of two (or two equivalent sets) of power amplifier modules for a balanced 70-volt (or 49-volt in modified version) output. Refer to Figure 12 and appropriate paragraphs under OUTPUT CONNECTIONS.

The bridging switch for the Model 2250 Driver Module is designated S202; see Figure 14. Bridging switches for the Model 2252 Driver Module are designated S202 and S402. Always leave the bridging switches OFF (open) unless the application specifically requires closure for a bridged configuration. Bridged switching is identical for SA type modules.

Attenuation Controls

An attenuation control is provided for each driver amplifier circuit of the driver module. Attenuation is continuously adjustable from 0 to -60 dB for Models 2250, 2251 and 2252. See Figure 14. Step attenuators are provided for the SA type modules, adjust-

able in increments of 1 dB from 0 to -63 dB. See Figure 15. A study of the modular block diagram illustrates that the attenuation controls are especially useful to establish several signal levels from a single source signal.

Attenuation Switching of SA Type Driver Modules

SA type driver modules are equipped with step attenuators. Six attenuation switches for each driver amplifier circuit provide 1, 2, 4, 8, 16 and 32 dB attenuation. By closing the switches in various combination, any attenuation may be obtained in 1 dB steps, to a maximum of 63 dB. See Figure 16. For example, closing switches 1, 2, and 5 provide an attenuation of 19 dB.

Electronic Crossover Switching

The option of electronic crossover is provided on the Model 2251 Crossover Driver Module; see Figure 17. Two-way or three-way crossover operation may be selected with BI/TRI switch S3. Crossover frequencies may be selected with switches S1 and S2. Switches S1 and S2 each have four positions to select crossover frequencies as indicated in Figure 17.

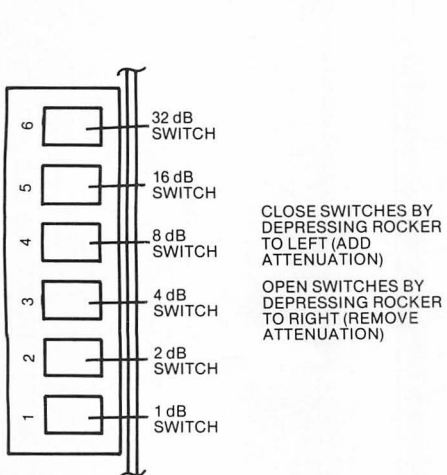

Figure 16. Attenuation Switching of SA Type Driver Modules

CAUTION
Do not actuate any switches on the crossover driver module while primary ac power is turned on. Failure to observe this precaution will introduce a large transient which may cause damage to loudspeakers connected to the system.

Matrix switches S101, S201, and S301 connect the high-frequency, mid-frequency, and low-frequency driver amplifier circuits to the inputs of the power amplifier modules. For example, to route high frequency signals to power amplifier module #1, close the #1 output matrix switch of S301. To route low frequency signals to power amplifier modules #4 and #5, close output matrix switches #4 and #5 of S101.

A study of the Modular Block Diagram will indicate a variety of configurations to distribute signals for bi-amplification and tri-amplification. Note that the bi-amplification mode of operation enables the mid-frequency driver amplifier circuit to be used as a full range driver amplifier, with level control, by connecting this signal source at special input/output jack J214; see applications example given in Figure 20 for an illustration of this case.

Filter output lines 10, 11 and 12 respectively feed the low, mid, and high frequencies to the input of a Model 2250 or 2252 Driver Module, and to the special input/output jacks J213, J214, J215, and J216. Thus the low, mid, and high frequency outputs of the crossover driver module are accessible to feed another Incremental Power System, a Model 9440 Power Amplifier, or other device.

Rated load impedance of low, mid, or high frequency direct filter outputs of the crossover driver is 3000 ohms minimum.

MODULE EXTENDER CARDS

Module extender cards permit any of the system modules to remain operational when physically removed from the main frame. This facilitates final adjustments of the input and driver modules, and simplifies troubleshooting. Use the Model 2299 Extender Card with any input module or driver module; use the three adjustment nuts to

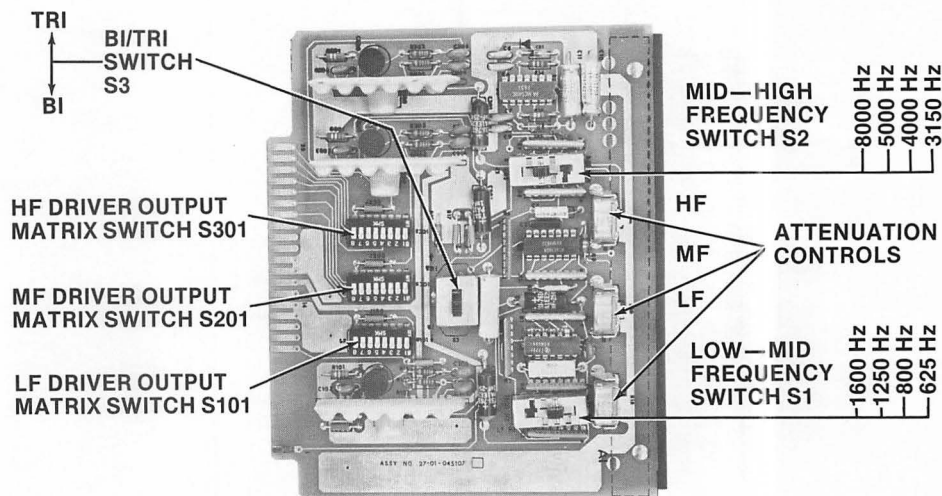

Figure 17. Electronic Crossover Switching for Model 2251 Driver Module

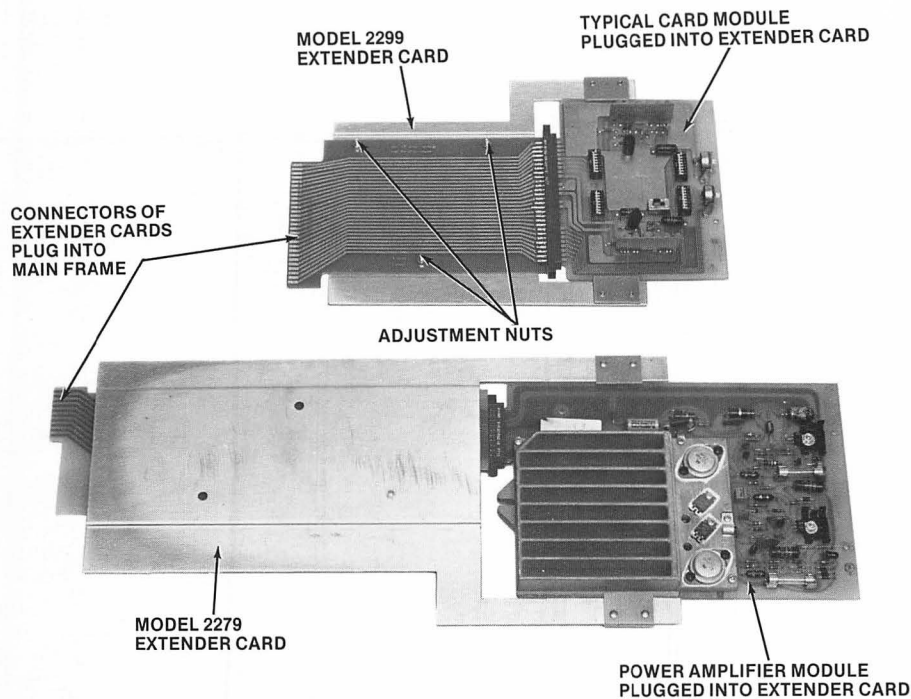

Figure 18. Extender Cards for Use with System Modules

properly orient the card and frame with respect to the module plugged in. Use the Model 2279 Extender Card with any power amplifier module. Figure 18 illustrates the two types of extender cards.

Always turn off primary ac power to the Incremental Power System before changing the settings of any switches on the driver (or crossover driver) module. Adjustment of attenuators on the input and driver modules may be accomplished while the system is in operation.

SUMMARY OF PRECAUTIONS AND GOOD PRACTICES

1. Do not operate or store an Incremental Power System with paralleled power amplifier modules *unless driver amplifier outputs are properly assigned to the inputs of the paralleled power amplifier modules.*

2. When paralleling power amplifier modules, make all parallel connections *only at terminal blocks TB201 (HIGH) and TB202 (COM)*, using jumper bars supplied with the accessory kit. Do not parallel power amplifier modules at the loudspeakers, or the modules may overheat due to improper sharing of load.

3. When outputs of two or more power amplifier modules are paralleled, their *inputs must also be paralleled.* Mismatched (non-parallel or unassigned) inputs to paralleled power amplifier modules will cause fuses to blow within the amplifier modules.

4. Do not operate an Incremental Power System without installing at least one driver card module.

5. Never remove any driver card module from the main frame while primary ac power is turned on.

6. Do not operate any switches of driver (or crossover driver) modules while primary ac power is turned on, with the exception of step attenuation switches of SA type driver modules.

7. Use only *stereo* (tip, ring, and sleeve) phone plugs in special input/output jacks J213, J214, J215, and J216. Standard phone plugs (tip and sleeve) will short-circuit internal wiring.

8. If the power amplifier modules are modified for 8 ohms load impedance, make certain that the power supply voltage secondary taps (main frame) are connected for the low voltage position; see Figure 7. Do not mix 8-ohm and 16-ohm power amplifier modules within a given main frame. Power amplifier modules modified for 8 ohms. Power amplifier modules with a load impedance of 16 ohms may be used either in a 8-ohm or 16-ohm main frame.

9. Leave all unused (unassigned) driver matrix switches OFF (open) to avoid possible misrouting of input signals.

10. It is good practice to assign the highest power demands to the power amplifier module nearest the cooling fan.

APPLICATIONS EXAMPLES FOR THE INCREMENTAL POWER SYSTEM

A few typical configurations of the Incremental Power System are given in Figures 19 through 23. These illustrations are photo-reductions of finished Modular Block Diagrams. A study of these systems will reveal the versatility and flexibility of the Incremental Power System.

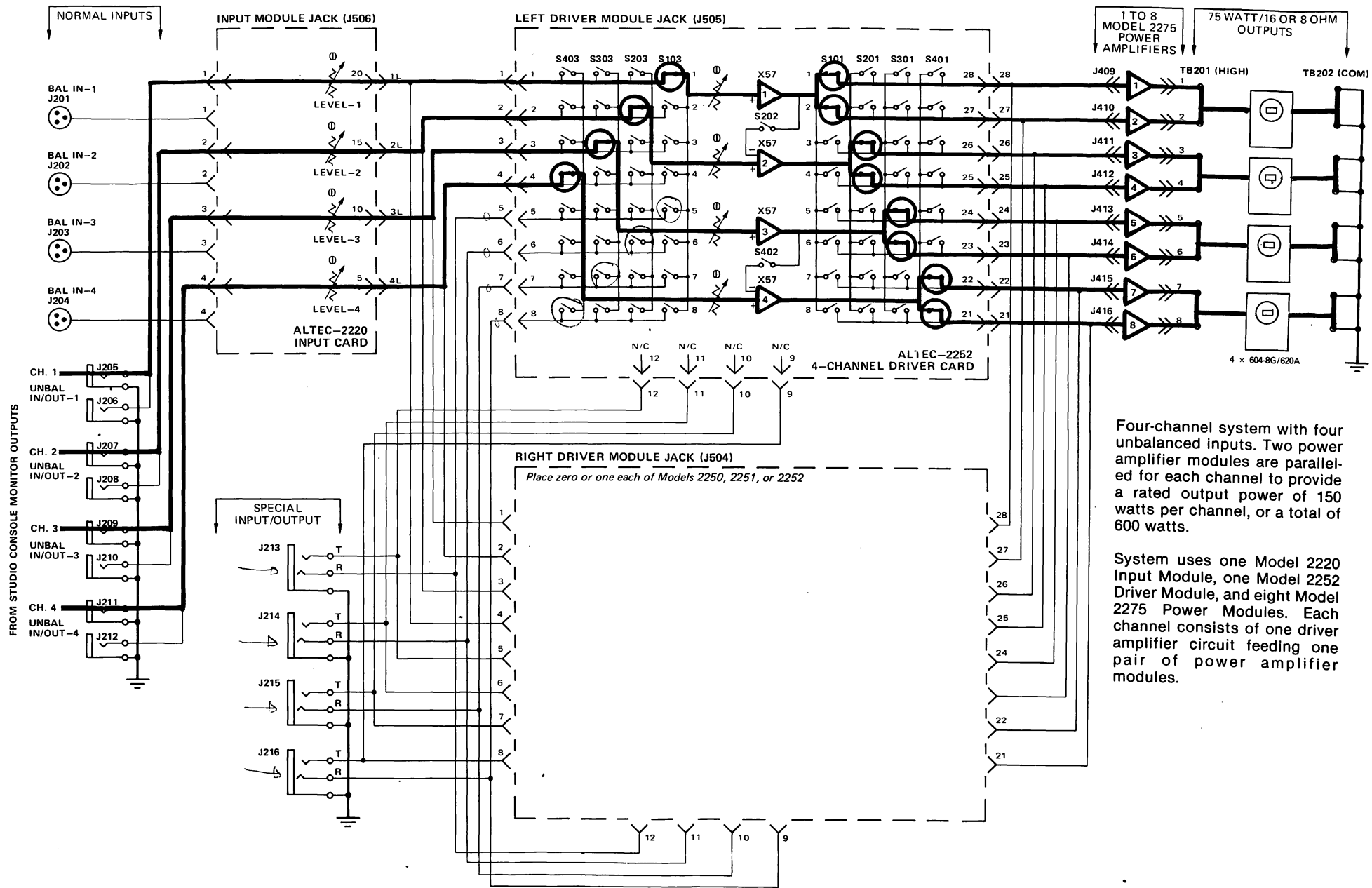

Four-channel system with four unbalanced inputs. Two power amplifier modules are paralleled for each channel to provide a rated output power of 150 watts per channel, or a total of 600 watts.

System uses one Model 2220 Input Module, one Model 2252 Driver Module, and eight Model 2275 Power Modules. Each channel consists of one driver amplifier circuit feeding one pair of power amplifier modules.

clock: stop 5/82 miscot

Figure 19. Four-Channel System with Rated Output of 600 Watts

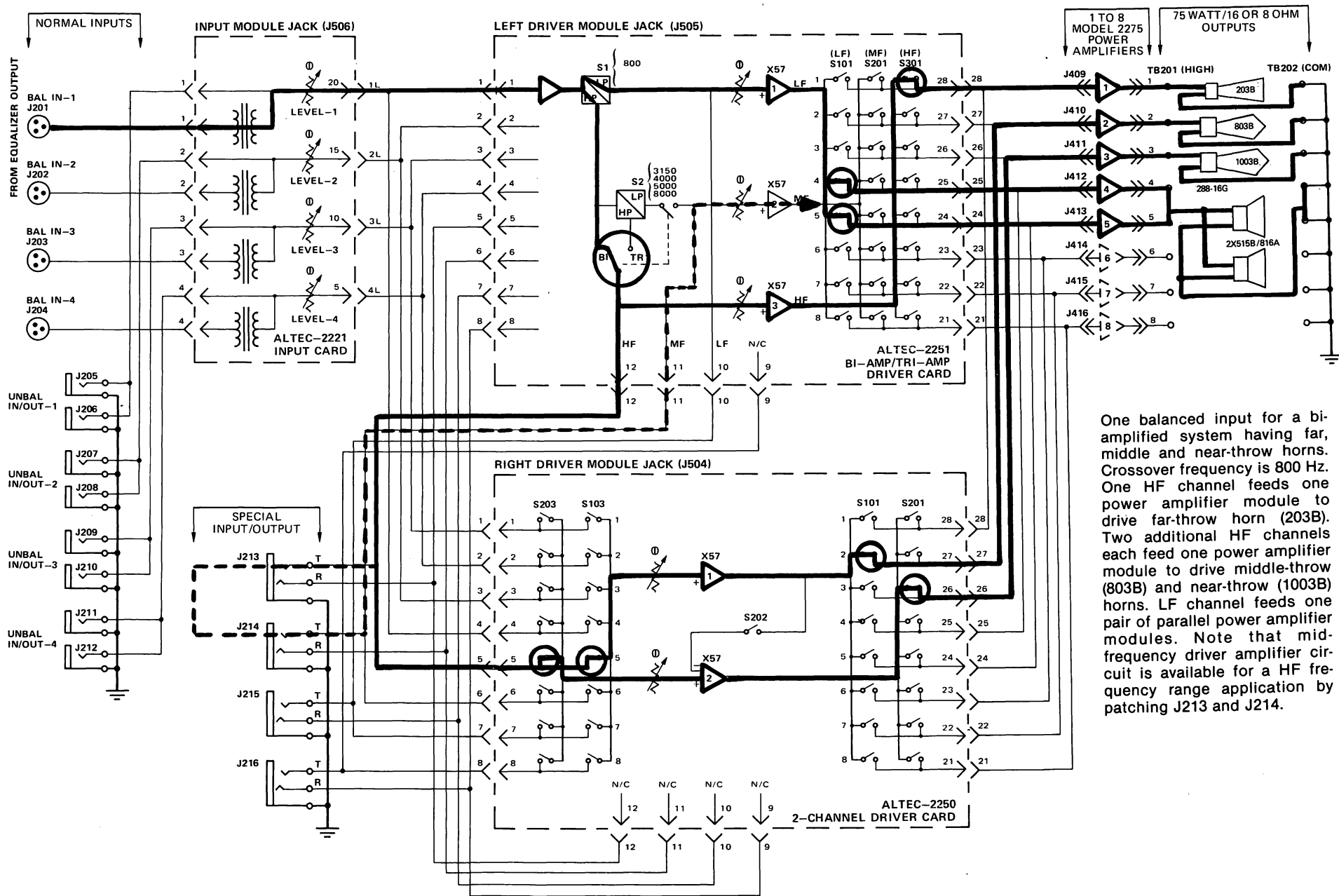

One balanced input for a bi-amplified system having far, middle and near-throw horns. Crossover frequency is 800 Hz. One HF channel feeds one power amplifier module to drive far-throw horn (203B). Two additional HF channels each feed one power amplifier module to drive middle-throw (803B) and near-throw (1003B) horns. LF channel feeds one pair of parallel power amplifier modules. Note that mid-frequency driver amplifier circuit is available for a HF frequency range application by patching J213 and J214.

Figure 20. Bi-amplified Configuration with Far, Middle, and Near-Throw Horns

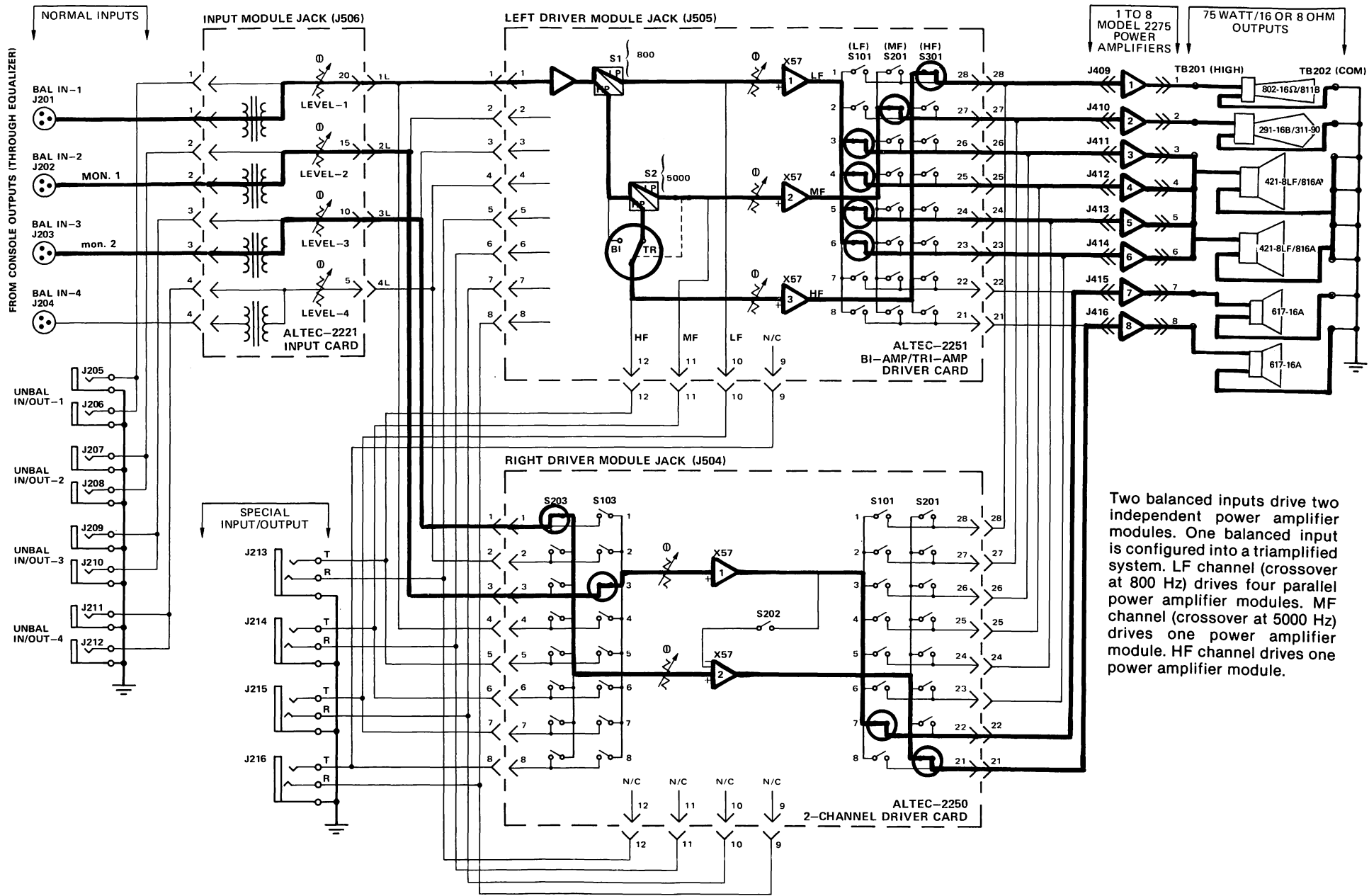

Two balanced inputs drive two independent power amplifier modules. One balanced input is configured into a triamplified system. LF channel (crossover at 800 Hz) drives four parallel power amplifier modules. MF channel (crossover at 5000 Hz) drives one power amplifier module. HF channel drives one power amplifier module.

Figure 21. Triamplified Configuration and Two Full Range Channels

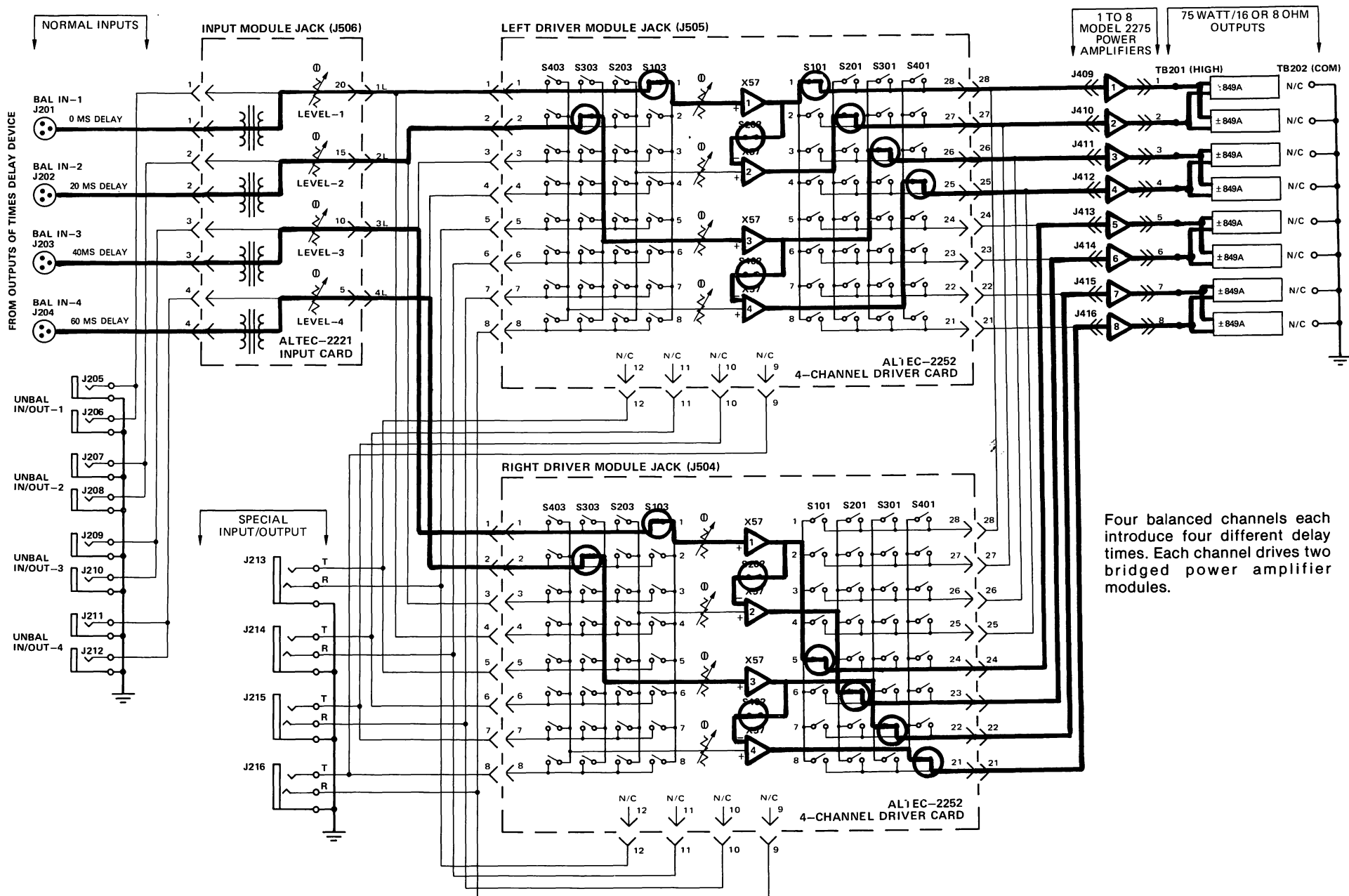

Four balanced channels each introduce four different delay times. Each channel drives two bridged power amplifier modules.

Figure 22. Bridged Configuration Incorporating Time Delay

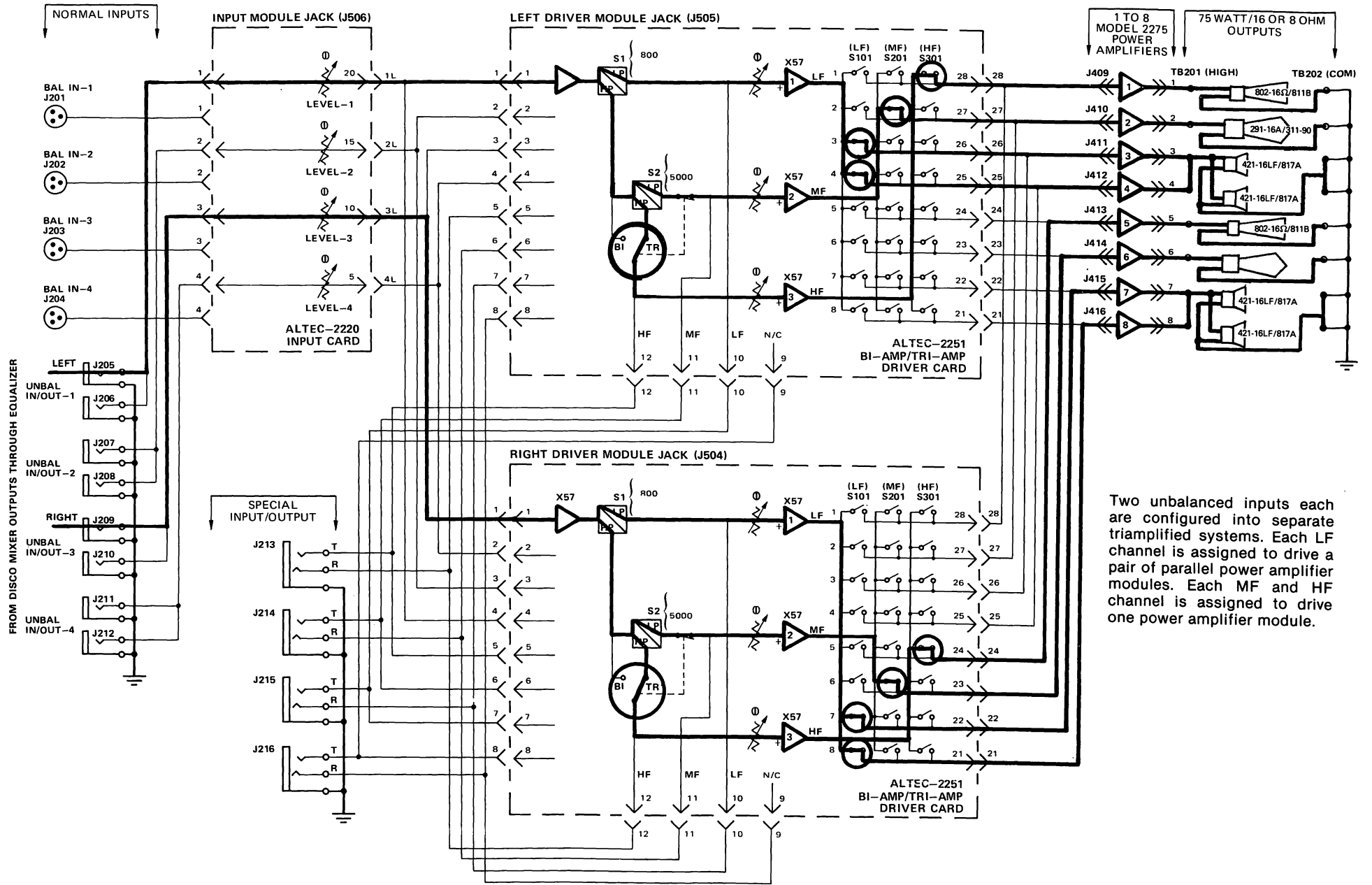

Two unbalanced inputs each are configured into separate triamplified systems. Each LF channel is assigned to drive a pair of parallel power amplifier modules. Each MF and HF channel is assigned to drive one power amplifier module.

Figure 23. Stereo Triamplified System

SYSTEM SPECIFICATIONS FOR INCREMENTAL POWER AMPLIFIERS

<p>Voltage Amplification (Maximum) From input of Model 2220 Input Card through Model 2250 or 2252 Driver Card to output of Power Amplifier Module.</p> <p>From input of Model 2220 Input Card through Model 2251 Crossover Card to output of Model 2275 Power Amplifier.</p>	<p>35.0 dB in independent or parallel mode, 41.0 dB in bridge or parallel/bridge mode (all attenuators at full CW rotation).</p> <p>35.0 dB to output of Power Amplifier Modules assigned to the "Low" output of the 2251 Crossover Card; 36.7 dB to output of Power Amplifier Modules assigned to the "Mid" output of the 2251 Crossover Card; 47.0 dB in Bi-Amplifier, 50.6 dB in Tri-Amplifier to output of 2275 Power Amplifier Modules assigned to the "High" output of the 2251 Crossover Card; 35.0 dB to output of power amplifier in bi-amplifier mode using full range channel (MF channel of 2251 driver). (Values apply to Power Amplifier Modules in independent or parallel mode; add 6 dB to values for Power Amplifier Modules used in bridge or parallel/bridge modes; all values assume full CW rotation of appropriate attenuators.)</p>
<p>Voltage Amplification (Maximum) From input of Model 2220 Input Card through Model 2251 Crossover Card to Special Input/Output Jacks J213, J214, or J215.</p>	<p>+ 15.0 dB to J213 ("High" output); + 11.5 dB to J214 ("Mid" output); - 0.5 dB to J215 ("Low" output). (All attenuators at full CW rotation.)</p>
<p>Minimum Load Impedance For Special Input/Output Jacks 213, 214, and 215.</p>	<p>300 ohms.</p>
<p>Voltage Amplification (Maximum) From special Input/Output Jacks J213, J214, J215, or J216 through 2250 or 2252 Driver Card to output of Model 2275 Power Amplifier.</p>	<p>35.0 dB in independent or parallel mode; 41.0 dB in bridge or parallel/bridge mode. (All attenuators at full CW rotation.)</p>
<p>Input Sensitivity Input voltage needed at 2220 Input Card inputs for rated output from Model 2275 Power Amplifier with 2250 or 2252 Driver Card.</p>	<p>- 2.0 dB* (0.61V) for 16Ω operation, - 4.9 dB (0.44V) for 8Ω operation with appropriate attenuators at maximum CW rotation; Input Sensitivity is the same for all operational modes of Power Amplifier Modules.</p>
<p>Input Sensitivity Input voltage needed at 2220 Input Card inputs for rated output from Model 2275 Power Amplifier with Model 2251 Crossover Card.</p>	<p>- 2.0 dB (0.61V) for 16Ω operation, - 4.9 dB (0.44V) for 8Ω operation with appropriate attenuators at maximum CW rotation; Input Sensitivity is the same for all operational modes of Power Amplifier Modules.</p>
<p>Input Impedance At Special Input/Output Jacks J213, J214, J215, J216 with Model 2250 or 2252 Driver Card.</p>	<p>29K ohms.</p>
<p>Input Sensitivity Input Voltage needed at Special Input/Output Jacks J213, J214, J215 or J216 for maximum output from Model 2275 Power Amplifier with 2250 or 2252 Driver Card.</p>	<p>- 2.0 dB (0.61V) for 16Ω operation, - 4.9 dB (0.44V) for 8Ω operation with appropriate attenuators at maximum CW rotation; Input Sensitivity is the same for all operational modes of Power Amplifier Modules.</p>
<p>AC Power Requirements (2200 Main Frame with 8-Model 2275 Power Amplifiers, Model 2221 Input Card, Model 2252 Driver Card.)</p>	<p>120V AC, 50 or 60 Hz; 1100 W AC line power at full power (600 W) output. 1 kHz input: 660W AC line power at 1/3 power (200W) output, 1 kHz input: 360W AC line power at 1/10 power output (60W or - 10 dB from full output power), pink noise input.</p>
<p>Export Conversion Voltages</p>	<p>100, 120, 200, 220, 240V AC, 50 or 60 Hz</p>
<p>Connectors (Main Frame)</p>	<p>(4) D3F Channel 1-4 Input Connectors. (XLR-type three-pin female.) (8) 1/4" TS Phone Jack Input Connectors (in pairs with each pair corresponding to an input channel). (4) 1/4" TRS (stereo) Phone Jack Special Input/Output connectors. (2) Eight-position terminal blocks, (one "HIGH", one, "COM") corresponding to the outputs of the eight possible Model 2275 Power Amplifiers. (1) Three-pin (grounded) AC power cable connector. (8) 10-position card-edge connectors for up to eight Model 2275 Power Amplifiers or four Model 2276 Power Amplifiers. (3) 28-position card-edge connectors for the Input, Driver and Crossover Cards.</p>
<p>Controls and Indicators (Model 2220 Main Frame)</p>	<p>(1) Combination AC-power-switch/circuit-breaker/pilot-lamp.</p>

* In these specifications, when dB represents a specific voltage, 0 dB is referenced to 0.775 volts rms. 'dB' is a voltage level, whereas 'dbm' is a power level. 0 dBm is referenced to 1 mW (0.775 volts driving a 600-ohm termination). For example, when 6.16 volts drives a high impedance, the level is designated + 18 dB. When 6.16 volts drives a 600-ohm termination, the level is designated + 18 dBm.

SYSTEM SPECIFICATIONS FOR INCREMENTAL POWER AMPLIFIERS (CONTINUED)

Dimensions and Weights									
	Full Model 2200 Main Frame	Empty Model 2200 Main Frame	Model 2220 Input	Model 2250 Input	Model 2252 Driver	Crossover/Driver	Model 2251 Power Driver	Model 2275 Power Amplifier	Model 2276 Power Amplifier
Weight	70 lb (31.7 kg)	50 lb (25.4 kg)	6 oz (170 gm)	17 oz (481 gm)	5 oz (141 gm)	7 oz (198.4 gm)	7 oz (198.4 gm)	24 oz (680.4 gm)	2 lbs, 12 oz (1.25 kg)
Length	17-5/8" (447.7 mm)	17-5/8" (447.7 mm)	5-1/2" (140 mm)	5-1/2" (140 mm)	5-1/2" (140 mm)	5-1/2" (140 mm)	5-1/2" (140 mm)	10-1/8" (257.2 mm)	10-1/8" (257.2 mm)
Width	19" (483 mm)	19" (483 mm)	1 3/8" (34.9 mm)	1 3/8" (34.9 mm)	1 3/8" (33.3 mm)	1-5/16" (33.3 mm)	1-5/16" (33.3 mm)	1-1/4" (31.3 mm)	2-5/8" (66.6 mm)
Height	7" (178 mm)	7" (178 mm)	6-1/2" (165.1 mm)	6-1/2" (165.1 mm)	6-1/2" (165.1 mm)	6-1/2" (165.1 mm)	6-1/2" (165.1 mm)	6-1/2" (165.1 mm)	6-1/2" (165.1 mm)
Finish (Front panel of 2200 Main Frame)					Altec Green				

Model 2220 Input Module Specifications

Type	Input Card: 4 Unbalanced inputs with attenuators on each input.
Attenuator Specifications	25 K ohm audio-taper potentiometer with at least 60 dB attenuation at full CCW rotation.
Maximum Input Level	+ 30 dB (24.5 volts)
Input Impedance	25K ohms

Model 2221 Input Module Specifications

Type	Input Card: 4 Balanced, transformer-isolated inputs with attenuators on each input.
Attenuator Specifications	25K ohm audio-taper potentiometer with at least 60 dB attenuation at full CCW rotation.
Transformer Specifications	(Similar to Altec Model 15335A) Turn Ratio: 1:1 Impedance: 15K ohms primary and secondary Frequency Response: ± 1 dB, 20 Hz to 20 kHz Maximum Input Level: + 21 dB (8.70 volts) Insertion Loss: 0.7 dB

Model 2250, 2250SA, 2252, and 2252SA Driver Module Specifications

Type	Models 2250: Driver Card with 2 driver amplifiers, input and output switch matrix and 2 attenuators. Models 2252: Driver Card with 4 driver amplifiers, input and output switch matrix and 4 attenuators.
Driver Amplifiers	× 57.3 (35.2 ± .2 dB voltage amplification) amplifiers designed specifically to drive the Models 2275 and 2276 Power Amplifiers.
Switches	Matrix Switches: DIP (dual inline package) SPST switches—8-switches per DIP; 2 input DIPS and 2 output DIPS for Models 2250; 4 input DIPS and 4 output DIPS for Models 2252. Bridging Switches: Slide-type switch to bridge the outputs of two Model 2275 or 2276 Power Amplifiers for a 70-volt balanced output. 1 bridging switch for Models 2250, 2 bridging switches for Models 2252.
Performance Specifications	Included with Model 2275 and 2276 Power Amplifier Specifications.
Attenuators (Models 2250, 2252)	One 50K ohm audio taper potentiometer at the input of each driver amplifier; at least 60 dB attenuation at full CCW rotation.
(Models 2250SA, 2252SA)	One six-position DIP switch for each attenuator with sumable steps of 1-2-4-8-16-32 dB; (maximum 63 dB attenuation); for attenuators for the Model 2252SA, two attenuators for the Model 2250SA.

Models 2251 and 2251SA Crossover Driver Module Specifications

Type	2-way or 3-way electronic crossover card with 3 driver amplifiers and an output switch matrix.
Crossover Frequencies	625 Hz, 800 Hz, 1250 Hz, 1600 Hz (Low/Mid); 3150 Hz, 4000 Hz, 5000 Hz, 8000 Hz (Mid/High).
Slope Rate	12 dB/octave
Frequency Response	Each filter is -3 dB at the selected crossover frequency. The LOW output is less than -0.5 dB at 20 Hz; the HIGH output is less than -0.5 dB at 20 kHz. All filters are essentially flat within their respective passbands.
Phase Response	All filters conform to standard "butterworth" phase response within $\pm 20^\circ$
Total Harmonic Distortion	Less than 0.1% from 20 Hz to 20 kHz from any driver amplifier output, all attenuators at full CCW rotation.
Hum and Noise	95 dB Signal to Noise ratio at driver amplifier outputs with equal channel gains.
Maximum Voltage Amplification from 2220 Input to Special Input/Output Jacks J213, J214 or J215	+ 15.0 dB (+ 11.5 dB in bi-amplifier) to J213 ("HIGH" output); + 11.5 dB to J214 ("MID" output); - 0.5 dB to J215 ("LOW" output). Note: LOW, HIGH and MID attenuators do not affect the output level at the Special Input/Output Jacks J213, J214 and J215.

Minimum Load Impedance on Special Input/Output Jacks J213, J214, J215	3000 Ohms (actual output impedance is 270 Ω).
Switches	3 DIP (dual inline package) output bus matrix switches—8-SPST switches per DIP; 1 "BI/TRI" switch, 2 Crossover Frequency Switches.
Driver Amplifiers	$\times 57.3$ (35.2 \pm .2 dB voltage amplification) amplifiers designed specifically to drive the Models 2275 and 2276 Power Amplifiers. 3 driver amplifiers, one each for the HIGH, MID and LOW outputs. Driver amplifiers drive the Models 2275 and 2276 Power Amplifiers but do not drive the Special Input/Output Jacks J213, J214 and J215. Mid Output may be used as a full-range channel in bi-amplifier mode with an input attenuator accessible through J214.
Attenuators Model 2251	LOW, HIGH and MID driver amplifiers have 50K ohm audio taper input attenuators with at least 60 dB attenuation at maximum CCW rotation.
Model 2251SA	LOW, MID and HIGH driver amplifiers each have a six-position DIP switch attenuator with sumable steps of 1-2-4-8-16-32 dB (maximum 63 dB attenuation).

Model 2275 Power Amplifier Specifications*

	Individual Model 2275 Driven by Model 2250 or 2252 Driver Card with Model 2220 Input Card	Eight Model 2275's in Parallel/Bridge Mode Driven by Model 2250 or 2252 Driver Card with Model 2220 Input Card
Power Output	75 watts continuous average sine wave power into a 16-ohm load impedance.	600 watts continuous average sine wave power into an 8-ohm load impedance.
Power Output at Clipping	90 watts at 1 kHz into a 16-ohm load impedance.	675 watts at 1 kHz into an 8-ohm load impedance.
Frequency Response	+ 0, - 0.5 dB from 20 Hz to 20 kHz	+ 0, - 0.5 dB from 20 Hz to 20 kHz
Total Harmonic Distortion	Less than 0.25% from 20 Hz to 15 kHz Less than 0.03% at 1 kHz, 75 watt output into 16-ohms	Less than 0.25% from 20 Hz to 15 kHz Less than 0.05% at 1 kHz, 600 watt output into 8-ohms
Damping Factor	57:1 @ 100 Hz	57:1 @ 100 Hz
Actual Output Impedance	0.28 ohm in series with 10 microhenries	0.14 ohm in series with 5 microhenries
Hum and Noise	96 dB signal to noise ratio	93 dB signal to noise ratio
Separation Between Any Two Model 2275's	75 dB @ 1 kHz	(Does not apply)
Phase Shift	Less than $\pm 15^\circ$ from 20 Hz to 20 kHz	Less than $\pm 20^\circ$ from 20 Hz to 20 kHz
Offset Voltage	Less than ± 50 mV DC	Less than ± 100 mV DC
Indicator	One red LED "ON" indicator per 2275 turns off in the event of module failure.	
Fuses	(2) AGC-style 2.5 amp "fast blow" fuses per 2275 Power Amplifier	

* These specifications apply *only* to 16-ohm operation

	Individual Model 2276 Driven by Model 2250 or 2252 Driver Card with Model 2220 Input Card	Four Model 2276's in Parallel/Bridge Mode Driven by Model 2250 or 2252 Driver Card with Model 2220 Input Card
Power Output	150 watts continuous average sine wave power into a 8-ohm load impedance.	600 watts continuous average sine wave power into an 8-ohm load impedance.
Power Output at Clipping	180 watts at 1 kHz into a 8-ohm load impedance	675 watts at 1 kHz into an 8-ohm load impedance
Frequency Response	+ 0, - 0.5 dB from 20 Hz to 20 kHz	+ 0, - 0.5 dB from 20 Hz to 20 kHz
Total Harmonic Distortion	Less than 0.25% from 20 Hz to 15 kHz Less than 0.05% at 1 kHz, 150 watt output into 8-ohms	Less than 0.25% from 20 Hz to 15 kHz Less than 0.1% at 1 kHz, 600 watt output into 8-ohms
Damping Factor	57:1 @ 100 Hz	57:1 @ 100 Hz
Actual Output Impedance	0.14 ohm in series with 5 microhenries	0.14 ohm in series with 5 microhenries
Hum and Noise	96 dB signal to noise ratio	93 dB signal to noise ratio
Separation Between Any Two Model 2276's	75 dB @ 1 kHz	(Does not apply)
Phase Shift	Less than $\pm 15^\circ$ from 20 Hz to 20 kHz	Less than $\pm 20^\circ$ from 20 Hz to 20 kHz
Offset Voltage	Less than ± 50 mV DC	Less than ± 100 mV DC
Indicator	One red LED "ON" indicator per 2276 turns off in the event of module failure.	
Fuses	(2) AGC-style 5 amp "fast blow" fuses per 2276 Power Amplifier.	