

ALTEC®

1599A MIXER EXTENDER

OPERATING INSTRUCTIONS

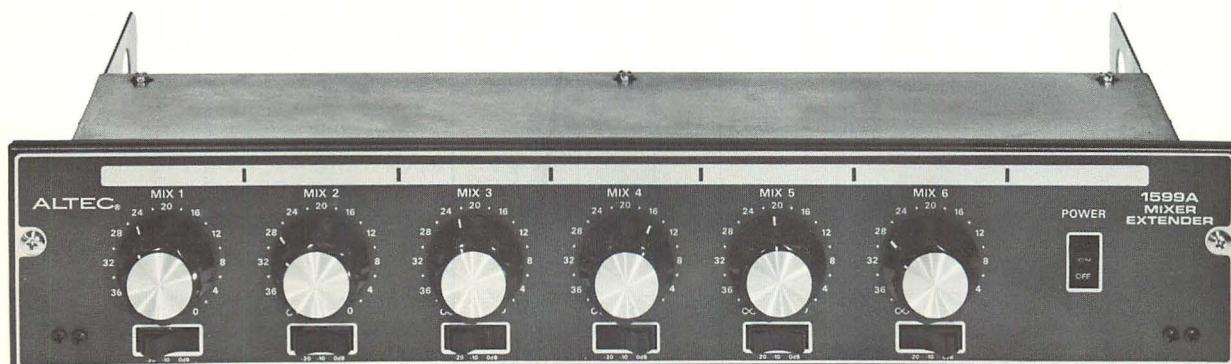

FEATURES

- Very Low Noise Level
- Controls and Mixes 6 Inputs
- +6 dBm Output into 600 Ohms
- Microphone Preamp Gain is Selectable at 0, -10 and -20 dB
- Provisions to Connect Additional Input Channels
- AC or Battery Operation
- Automatic Transfer to Battery Operation if AC Power Fails
- Hinged Front Panel for Easy Maintenance
- Small Size
- Light Weight
- Safety - Underwriters' Laboratories Listed

NOTICE

Read this manual before operating the 1599A Mixer Extender.

©Copyright 1975
Altec Corporation

Specifications and components subject to change without notice. Overall performance will be maintained or improved.

ALTEC®

SOUND PRODUCTS DIVISION

1515 S. Manchester Ave., Anaheim, Calif. 92803

42-02-044126-03

DATA CONTENTS

Item	Page
SPECIFICATIONS	3
DESCRIPTION	4
ACCESSORIES	4
INSTALLATION	4
MECHANICAL	4
<u>Rack Mounting</u>	4
<u>Shelf Mounting</u>	4
ELECTRICAL	5
<u>120V ac, 50/60 Hz Power Connections</u>	5
<u>240V ac, 50/60 Hz Power Connections</u>	5
<u>Battery Connections</u>	6
<u>Input Connections</u>	6
<u>Output Connections</u>	6
OPERATION	7
CONTROLS	7
WRITE-IN BLOCKS	7
SERVICE	8
ACCESS	8
BATTERY FUSE REPLACEMENT	8
REPLACEMENT OF PRINTED CIRCUIT BOARD (PCB)	8
RECOMMENDED SERVICE TECHNIQUES	8
<u>Orientation of Solid-State Components</u>	8
<u>Replacing Voltage Regulator (IC)</u>	8
<u>Testing Transistors</u>	8
<u>Replacing PCB Components</u>	8
<u>Repairing Fractured or Damaged PCB Conductor</u>	9
PARTS LIST	12
MAIN CHASSIS	12
SUMMING AND POWER PCB ASSEMBLY	12

Graphics	Title	Page
Figure 1.	1599A with Accessories and 1592B Mixer/Amplifier	4
Figure 2.	Front View 1599A with Hinged Panel Open	5
Figure 3.	Rear View 1599A	5
Figure 4.	Converting to 240V ac, 50/60 Hz Operation	6
Table I.	Plug-In Accessory Applications for Various Input Sources	6
Figure 5.	Input Wiring for Various Applications	6
Figure 6.	Individually Submastered 1599A Mixer Extenders	7
Figure 7.	Parallel Multiple Connections of 1599A Mixer Extenders	7
Table II.	Controls and Functions	7
Figure 8.	Operating Controls	7
Figure 9.	Typical Solid-State Component Configurations	8
Figure 10.	Chassis Components	9
Figure 11.	Schematic (3C474-5), 1599A Mixer Extender	10
Figure 12.	Electronic Part Locations (3C727-1), Summing and Power PCB Assembly	11
Figure 13.	Schematic (3C507-3), Summing and Power PCB Assembly	11

SPECIFICATIONS

Type:	6-channel solid-state mixer with provisions for plug-in input accessory modules
Gain:	48 dB with 1588C Microphone Preamplifier (gain may be reduced 10 or 20 dB with GAIN switch) -1 dB with 15095A Line Transformer bridging 600-ohm line 15 dB with 15356A Line Transformer
Input Clipping Level —	
With 1588B Microphone Preamplifier:	-22 dBm with GAIN switch at 0 dB -10 dBm with GAIN switch at -10 dB 0 dBm with GAIN switch at -20 dB
With 15095A Line Transformer:	Greater than 20 volts
Power Output:	1.5 volts (+6 dBm) at less than 0.5% THD 20 Hz to 20 kHz
Total Harmonic Distortion (THD):	Typically less than 0.1%
Frequency Response:	±1 dB from 20 Hz to 20 kHz
Source Impedance:	Up to 50,000 ohms with 1579C Equalized Preamplifier (unbalanced input) 150/250 ohms nominal with 1588C Microphone Preamplifier (balanced input) 600 to 15,000 ohms with 15095A Line Transformer (balanced bridging input) 150 to 600 ohms with 15356A Line Transformer (balanced matched input)
Minimum Load Impedance:	600 ohms
Output Impedance:	230 ohms nominal
Noise Level (20 kHz Bandwidth):	-124 dBm equivalent input noise from 20 Hz to 20 kHz

Controls:	6 MIX gain controls, continuously variable 6 GAIN switches, 3-position (0 dB, -10 dB and -20 dB) 1 POWER on-off line switch
Connections —	
Input:	6 XLR3-31 receptacles (INPUT 1-6)
Output:	2 phono jacks (MASTER MULTIPLE)
Battery Power:	2-terminal, barrier-type terminal board (- and +)
Accessory Mounting Sockets:	6 octal sockets (ACC-1 through ACC-6) for plug-in input accessory modules
Power Requirements:	120/240V ac, 50/60 Hz, 6 watts - or - 24/28V dc at 0.12A Battery minus (-) is ground
Operating Temperature Range:	Up to 55°C (131°F) ambient
Dimensions:	3-1/2"H x 19"W x 7"D
Color:	ALTEC green
Weight:	7 pounds
Accessories:	ALTEC 1579C Equalized Preamplifier ALTEC 1588C Microphone Preamplifier ALTEC 15095A Line Bridging Transformer ALTEC 15356A Line Matching Transformer ALTEC 42526 Shelf Mount Cover (7"H) ALTEC 42625 Shelf Mount Cover (8-3/4"H)

NOTE

ACCESSORIES MUST BE ORDERED SEPARATELY. One 1579C, 1588C, 15095A or 15356A must be ordered for each input channel used.

DESCRIPTION

The ALTEC 1599A Mixer Extender controls and mixes up to six independent input signals for a sound reinforcement system. Several 1599A Mixer Extenders may be used with a mixer/amplifier to expand the input capability of the sound system. Up to 30 inputs, each with separate GAIN control, may be applied to a single amplifier.

The 1599A may be used with any ALTEC amplifier having MASTER MULTIPLE input connectors. It also may be used independently where as many as six inputs are desired. The 1599A will drive a power amplifier having an input sensitivity of 0.1 volt rms.

The 1599A operates at an exceptionally low noise level and delivers up to +6 dBm output power. Optional plug-in input module accessories permit each of the six channels to be used for microphone, magnetic phono pickup or high-level line sources. Gain is 48 dB with the 1588C Microphone Preamplifier accessory. Each channel is provided with a GAIN switch to reduce gain by 10 or 20 dB to allow use of high-output microphones without introducing distortion.

ACCESSORIES

One plug-in input accessory is required for each channel used. These include the 1579C Equalized Preamplifier, the 1588C Microphone Preamplifier, the 15095A Line Bridging Transformer and the 15356A Line Matching Transformer (see Figure 1). Applications and requirements are summarized in Table I of the **INSTALLATION** section.

The ALTEC 42526 Shelf Mount Cover accessory encloses two 1599A units for shelf use. It tilts the units for easy access to front panel controls. The sides and top extend beyond the

front panels to prevent accidental changes to control settings. The shelf mount cover provides easier handling for portability and is sturdy enough to support lightweight equipment that is placed on top of it. Four polyethylene feet prevent marring of surfaces. The ALTEC green finish of the shelf mount cover matches the front panels of the 1599A units.

The 42625 Shelf Mount Cover is larger and accommodates one 1599A and any ALTEC amplifier having a height of 5-1/4" (see Figure 1).

INSTALLATION

MECHANICAL

The 1599A may be mounted in a standard 19-inch equipment rack or two units may be shelf-mounted when supplied with an ALTEC 42526 Shelf Mount Cover. Required vertical space for mounting the 1599A in an equipment rack is 3-1/2".

Rack Mounting

- Step 1. Remove two screws securing front panel; open and lower panel (see Figure 2).
- Step 2. Install 1599A in equipment rack with two screws supplied with unit.
- Step 3. Close front panel and secure with two screws previously removed.

Shelf Mounting

Two 1599A units may be shelf-mounted after installing the 42526 Shelf Mount Cover accessory.

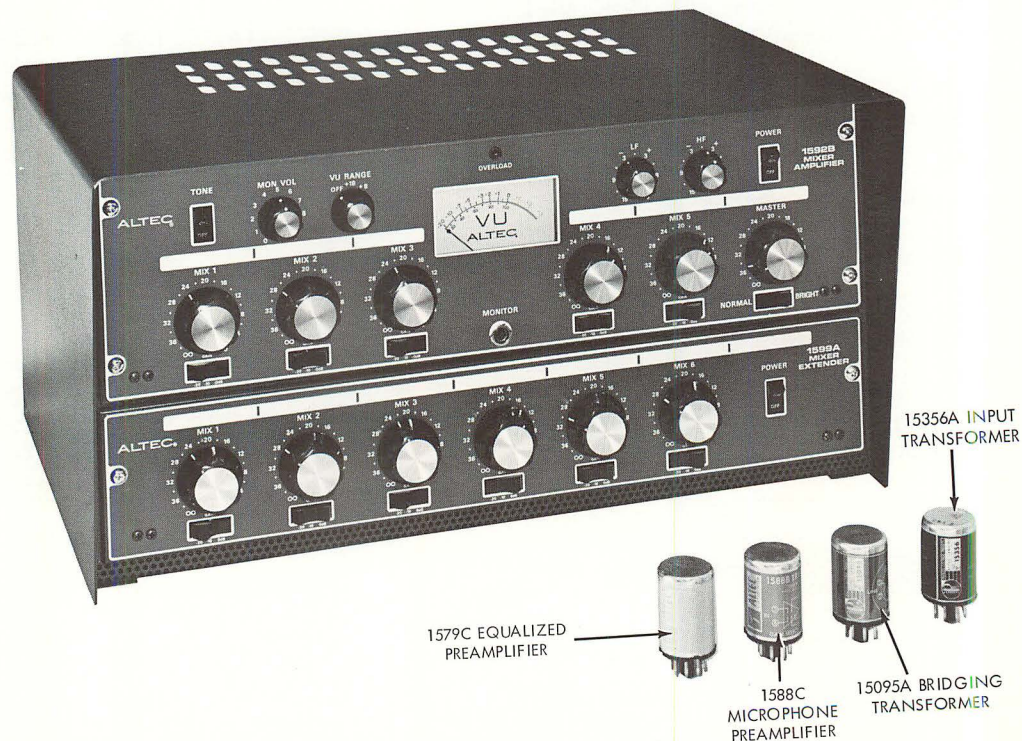

Figure 1. 1599A with Accessories and 1592B Mixer/Amplifier

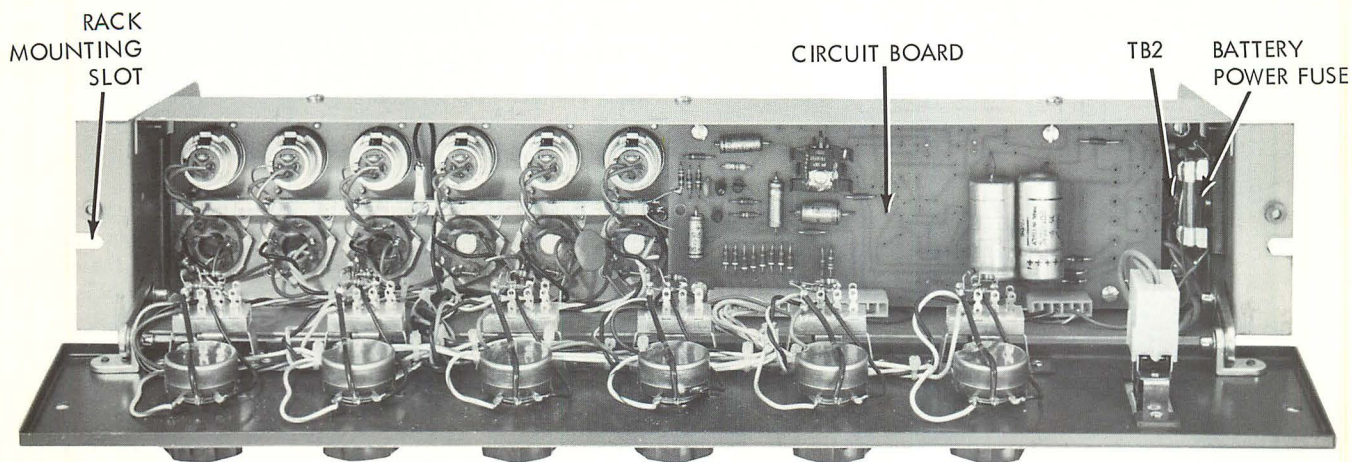

Figure 2. Front View 1599A with Hinged Panel Open

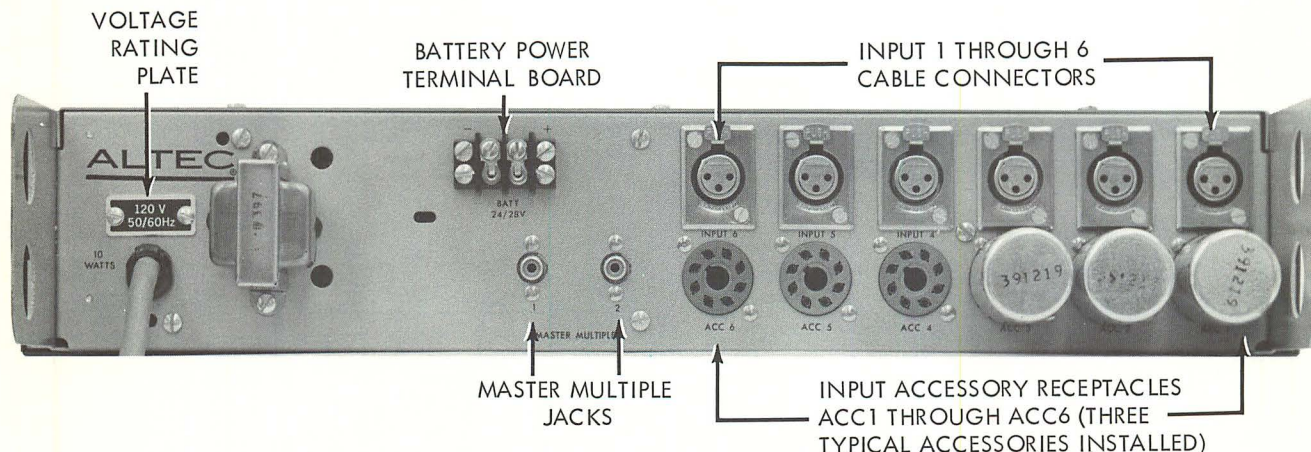

Figure 3. Rear View 1599A

ELECTRICAL

120V ac, 50/60 Hz Power Connections

Equipment supplied for domestic use is provided with the power transformer primary strapped for 120 volts (terminals 1 to 2 and 3 to 4 on TB2). The power input nameplate, adjacent to the power cord on the chassis, is mounted to show the appropriate side specifying the connections (see Figure 3). Verify that line voltage is in accordance with the voltage rating before connecting to primary power.

240V ac, 50/60 Hz Power Connections

Export equipment is provided with the power transformer primary strapped for 240 volts (terminals 2 to 3 on TB2). The power input nameplate, adjacent to the power cord on the chassis, is mounted to show the appropriate side specifying the connections.

For a 1599A previously wired for 120V ac primary power, use the following procedure to change wiring for 240V ac, 50/60 Hz operation:

- Step 1. Remove two screws securing front panel; open and lower panel.
- Step 2. Locate terminal board TB2 beneath power transformer T1 (see Figure 2).
- Step 3. Remove strap "A" connecting terminals 1 and 2, and remove strap "B" connecting terminals 3 and 4. Solder strap "C" to terminals 2 and 3 (see Figure 4).
- Step 4. Remove voltage-rating plate from chassis; reverse and re-install to show 240V rating (see Figure 3).
- Step 5. Close front panel and secure with two screws previously removed.

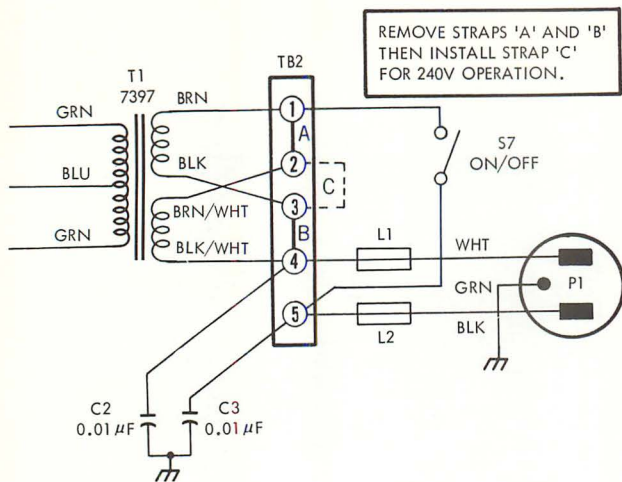

Figure 4. Converting to 240V ac, 50/60 Hz Operation

Battery Connections

If desired, the 1599A may be connected to an external 24/28-volt battery with minus (-) as ground. The battery power terminal board is shown in Figure 3. If ac power fails,, transfer to dc power is instantaneous, automatic and silent.

The battery power supply is not operated by the primary POWER switch. If switching of battery power is desired, an external relay or switch should be provided by the user.

Input Connections

Inputs to the mixer channels are connected on the chassis at connectors INPUT 1 through INPUT 6 (see Figure 3) with cables terminating in XLR3-12 type plugs. Appropriate internal wiring for these plugs is shown in Figure 5. Input for any channel may be microphone, magnetic phono or high-level line sources.

One plug-in input accessory is required for each channel used. Input accessories are selected to meet application requirements, and are plugged into the corresponding receptacle (ACC-1 through ACC-6). Applications of plug-in input accessories for various sources are shown in Table 1.

Table 1. Plug-In Accessory Applications for Various Input Sources

Input Source	Acceptable Source Impedance	Plug-In Input Accessory
Magnetic Phono	Up to 50,000 ohms (unbalanced input)	Use 1579C Equalized Preamplifier
Microphone	150/250 ohms nominal (balanced input)	Use 1588C Microphone Preamplifier
High-Level Line (Bridging)	Up to 15,000 ohms	Use 15095A Line Bridging Transformer
High-Level Line (Matching)	600 or 150 ohms	Use 15356A Line Matching Transformer

Output Connections

Two MASTER MULTIPLE output jacks (Figure 3) are provided for connecting the six outputs to a mixer or power amplifier. One shielded coaxial cable with a pin-tip phone plug connects the 1599A to the mixer or power amplifier. Either MASTER MULTIPLE output jack may be used.

One or more 1599A Mixer Extenders may be connected to an individually submastered system, as shown in Figure 6. All inputs of such a system appear at the output of the mixer/power amplifier. Each input is separately adjustable, and the MIX controls of the mixer/power amplifier function as 'system submasters' (master gain controls) for the appropriate 1599A. The 15095A Line Bridging Transformer accessories are used for the required input interface.

A parallel multiple system of 1599A Mixer Extenders is shown in Figure 7. Three 1599A units are connected via the MASTER MULTIPLE jacks to provide a system with up to 23 inputs. Only one MASTER gain control is available with this configuration.

Any combination of these two types of systems may be connected as a hybrid system, adding as many inputs as permitted by overall system performance (gain requirements).

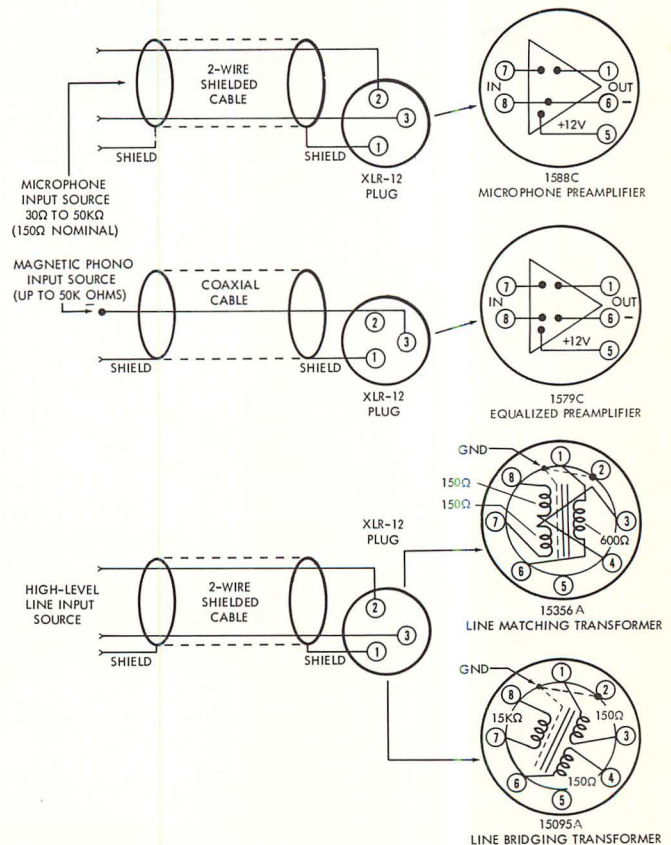

Figure 5. Input Wiring for Various Applications

EACH 1599A MIXER EXTENDER PROVIDES 6 INPUTS. UP TO 30 INPUT CHANNELS ARE AVAILABLE WITH 5 PARALLEL UNITS.

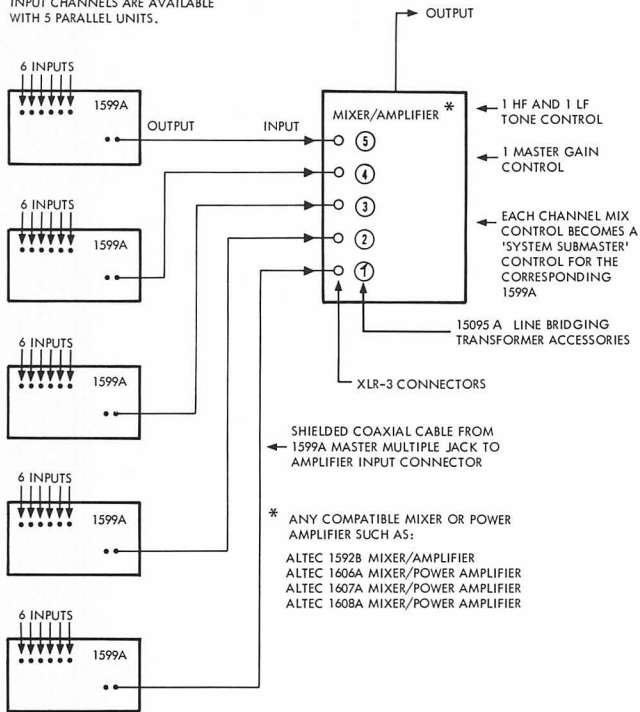

Figure 6. Individually Submastered 1599A Mixer Extenders

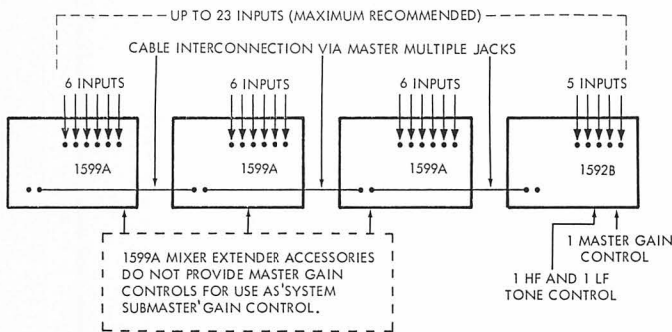

Figure 7. Parallel Multiple Connections of 1599A Mixer Extenders

OPERATION

CONTROLS

All operating controls are located on the front panel (see Figure 8). Controls and functions are given in Table II.

Table II. Controls and Functions

Name	Function/Description
MIX 1 - 6 controls	Provide attenuation for corresponding input channel. Continuously variable potentiometers, graduated from 0 dBm to ∞ . Turn clockwise (cw) to increase gain.
GAIN switches	Reduce gain -10 or -20 dB on corresponding input channels to allow use of high-output microphones without introducing distortion (when using 1588B Microphone Pre-amplifier accessory). Set switches to 0 dB for other applications such as use of 15095A or 15356A Transformer accessories. Turn associated MIX control counterclockwise (ccw) to ∞ before switching, to avoid system 'pops'.
POWER switch	Applies primary power to Mixer Extender

WRITE-IN BLOCKS

The write-in blocks above the six MIX gain controls may be marked with a soft lead pencil to identify use. To remove writing, use a damp cloth — never use a pencil eraser or other abrasive material.

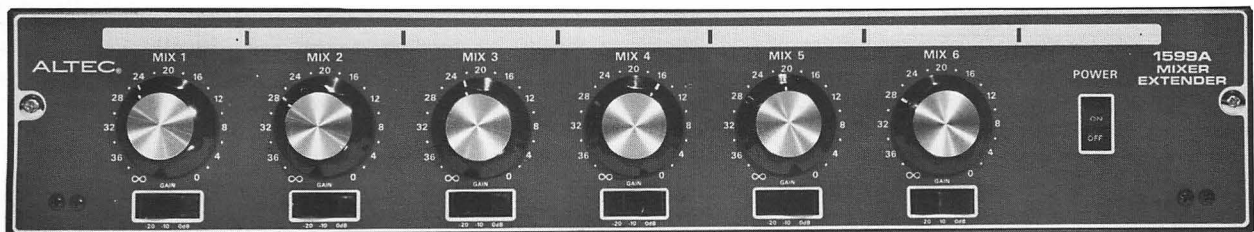

Figure 8. Operating Controls

SERVICE

If a malfunction occurs, service should be performed by an ALTEC Qualified Service Representative. For factory service, ship the 1599A prepaid to:

Customer Service
ALTEC
131 West Katella Avenue
Anaheim, California 92803

For additional information or technical assistance, call (714) 774-2900, or Telex 65-5415.

ACCESS

Remove two screws securing front panel, then open and lower hinged front panel to gain access to chassis interior.

BATTERY FUSE REPLACEMENT

The battery fuse is located within the chassis (see Figure 2). If fuse replacement is required, determine and correct any cause of failure before replacing fuse. Install an identical fuse (see **PARTS LIST**) by opening the front panel, removing the fuse from the clip holder and inserting a new fuse.

The ac primary power line is not fused because the power transformer has low current drain.

REPLACEMENT OF PRINTED CIRCUIT BOARD (PCB)

- Step 1. Remove two screws securing front panel; open and lower panel.
- Step 2. Carefully remove two plug connectors from PCB.
- Step 3. Remove four screws securing PCB to chassis and remove one screw and nut securing PCB to ground lug.
- Step 4. Install replacement (or repaired) PCB, securing with hardware removed in Step 3.
- Step 5. Carefully insert two plug-in connectors onto pin connectors of PCB until fully seated.
- Step 6. Close front panel and secure with two screws removed in Step 1.

RECOMMENDED SERVICE TECHNIQUES

If systematic troubleshooting indicates need for parts replacement, observe the following precautions:

Orientation of Solid-State Components

Solid-state components are packaged in various case sizes and types with various lead orientations (see Figure 9). Before removing a solid-state component from the PCB, sketch the lead orientation with respect to the PCB.

Form the leads of the new component to conform with the leads of the part being replaced to aid in making proper connections.

Before removing small transistors, note position with respect to the PCB or socket. Cut the leads of the new transistor to

the required length and insert them properly oriented into the PCB or socket.

Replacing Voltage Regulator (IC)

Verify no grit or metal particles are between replacement IC and heat sink. Verify heat sink contact area is coated with silicone grease or fluid and mounting screw is tight.

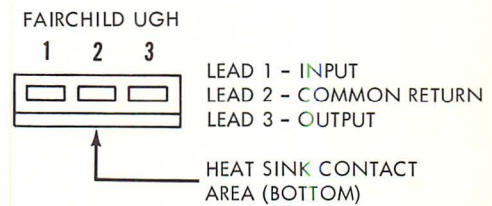

Figure 9. Typical Solid-State Component Configurations

Testing Transistors

Transistors should be checked with a transistor tester. If a tester is not available, use the following procedure for testing transistors with an ohmmeter:

- Step 1. Remove suspected transistor from circuit (see Replacing PCB Components).
- Step 2. Connect ohmmeter leads to base and emitter. Read on lowest ohms scale. Reverse leads and read again. Normal readings should be at least 10 times greater in one direction than in the other direction.
- Step 3. Connect ohmmeter leads to base and collector and repeat Step 2. Ohmmeter readings should be similar to those obtained in Step 2.
- Step 4. If Steps 2 and 3 show normal function, connect ohmmeter leads to collector and emitter. Read on lowest ohms scale. Reverse leads and read again. If reading is low and virtually unchanged when ohmmeter leads are reversed, the transistor has a short circuit between collector and emitter.

Replacing PCB Components

Component locations on the main chassis are shown in Figure 10. The main chassis schematic is shown in Figure 11. Component locations on the PCB are shown in Figure 12. PCB schematic is shown in Figure 13. Before removing PCB components for testing or replacement, read and observe the following instructions:

1. Solid-state components and PCB's may be damaged by excessive heat. Use a small soldering iron with a 1/8-inch diameter chisel tip. Use small-diameter, 60/40 rosin-cored solder.
2. Remove components by placing soldering iron on component lead on conductor side of PCB and pull out lead. Avoid overheating the conductor.

CAUTION

The conductor on the PCB is a metal surface plated with solder and laminated to the board. Too much pressure or overheating may lift the conductor from the board.

3. If component is faulty or damaged, clip leads close to component and then unsolder leads from board. Withdraw leads from component side.

4. Clear solder from circuit board holes before inserting leads of new component. Heat solder remaining in hole, remove iron and quickly insert a pointed nonmetallic object, such as a toothpick, from conductor side.
5. Shape new component leads and clip to proper length. Lead shape should provide stress relief for component. Insert leads in holes, observing same polarity or orientation of removed component. Apply heat and solder on conductor side.

Repairing Fractured or Damaged PCB Conductor

If a conductor is fractured, damaged or lifted from the circuit board, a recommended method of repair is to solder a section of good conducting wire along the damaged area and seal with epoxy.

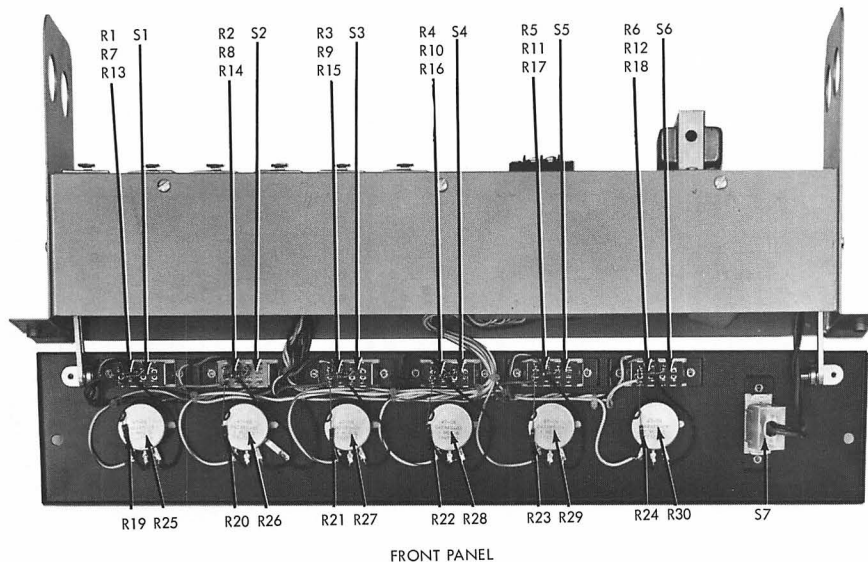
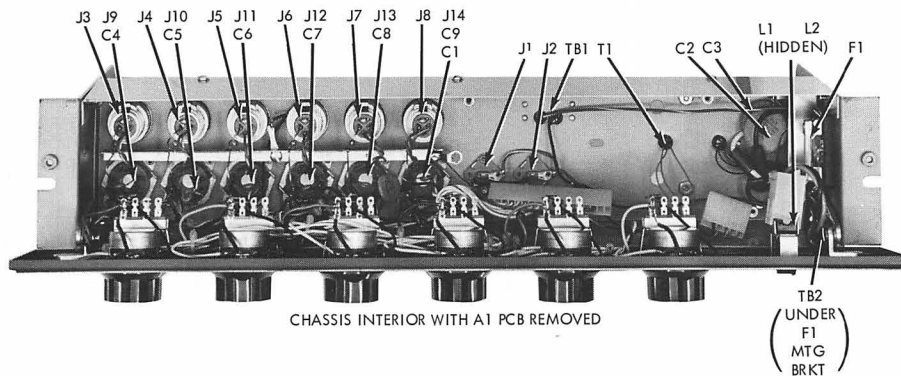

Figure 10. Chassis Components

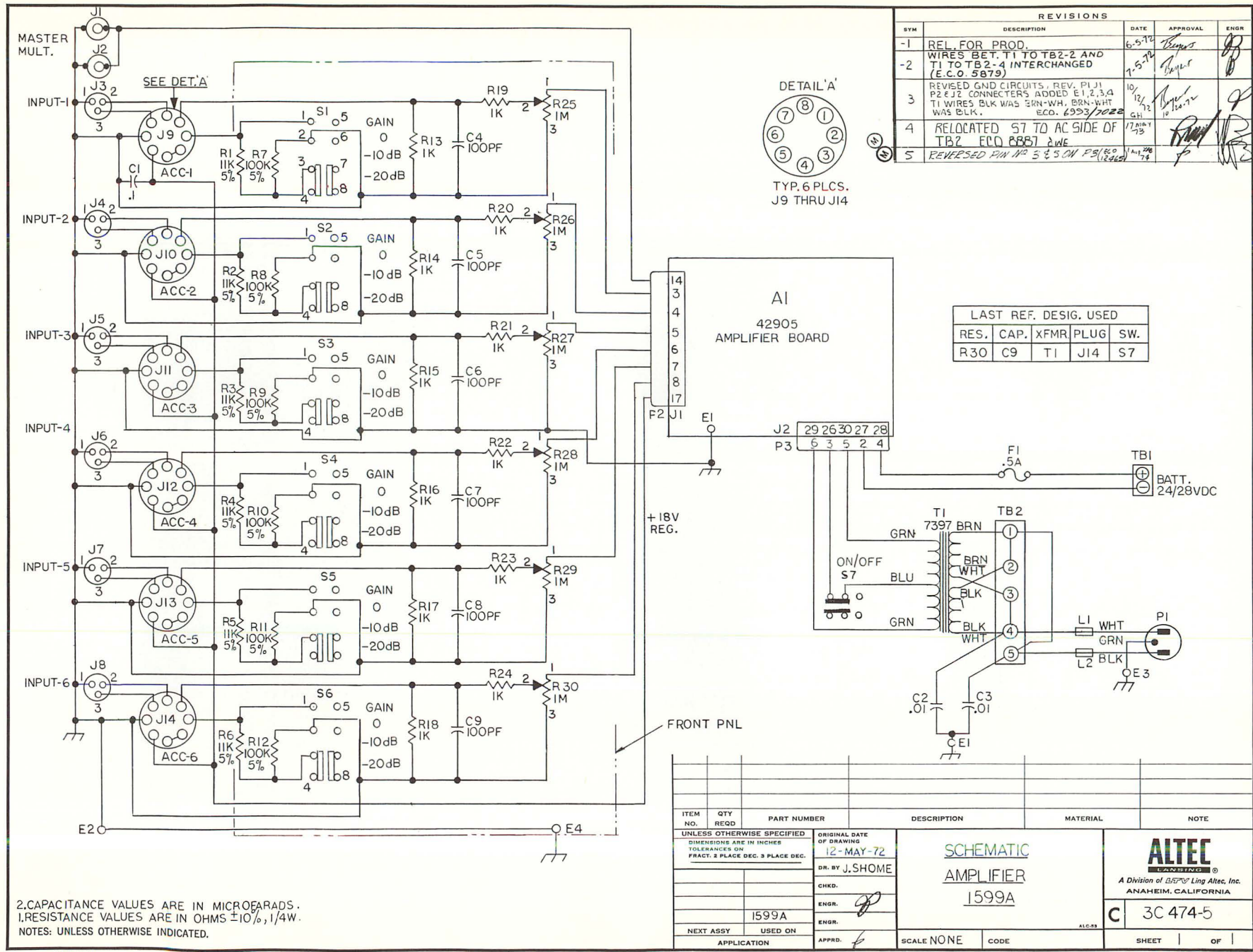

Figure 11. Schematic (3C474-5), 1599A Mixer Extender

ITEM NO.	QTY REQD	PART NUMBER	DESCRIPTION	MATERIAL	NOTE
UNLESS OTHERWISE SPECIFIED ORIGINAL DATE OF DRAWING 12-MAY-72					
DIMENSIONS ARE IN INCHES DR. BY J.SHOME					
TOLERANCES ON FRACT. 2 PLACE DEC. 3 PLACE DEC.					
CHKD.					
ENGR. <i>[Signature]</i>					
ENGR. <i>[Signature]</i>					
1599A					
NEXT ASSY USED ON					
APPR. <i>[Signature]</i>					
APPLICATION			SCALE NONE	CODE	

SCHEMATIC		ALTEC A Division of BENTON & BOWLES ANAHEIM, CALIFORNIA
AMPLIFIER		
1599A		C 3C 474-5
SHEET		OF

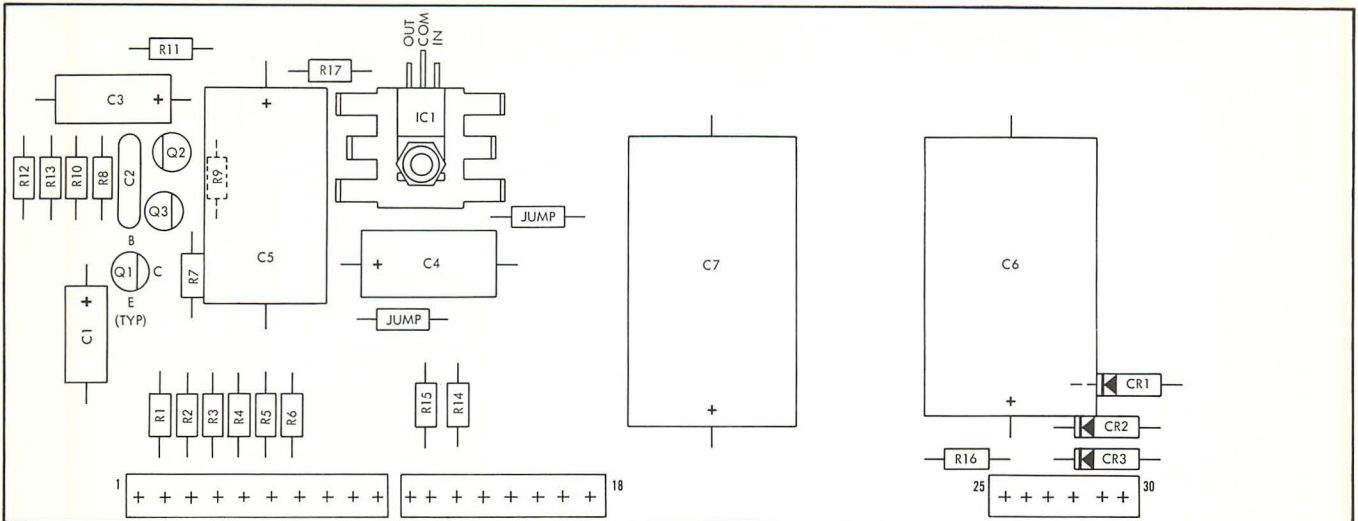

Figure 12. Electronic Part Locations (3C727-1), Summing and Power PCB Assembly

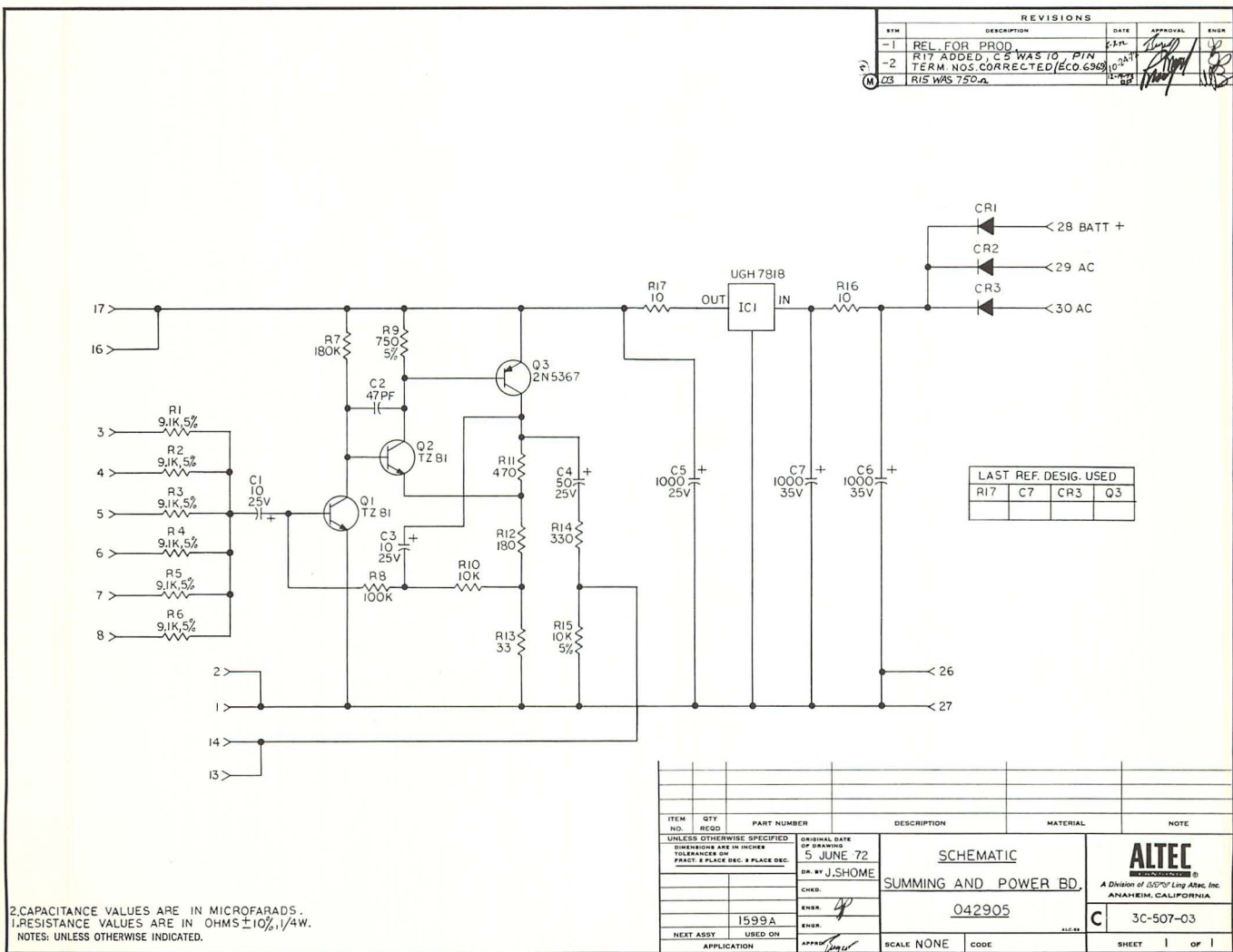

Figure 13. Schematic (3C507-3), Summing and Power PCB Assembly

PARTS LIST

MAIN CHASSIS

Reference Designator	Ordering Number	Name and Description
A1	27-01-042905-02	PCB assembly, summing and power
C1	15-02-100110-01	Cap., 0.1 μ F, 100V
C2,3	15-02-100089-01	Cap., 0.01 μ F \pm 20%, 1400V
C4,5,6,7,8,9	15-02-107454-01	Cap., 100 pF \pm 10%, 100V
F1	51-04-109448-01	Fuse, 0.5A, 3AG, slo-blo
J1,2	21-01-100508-01	Jack, phono, insulated ground
J3,4,5,6,7,8	21-02-113172-01	Receptacle, 3-terminal, XLR-3-31
J9,10,11,12,13,14	21-02-100973-01	Socket, octal
L1,2	56-01-044110-01	Choke, ferrite bead
P1	60-06-012636-03	Cord, 18GA, 3-conductor, 6 feet w/plug

Reference Designator	Ordering Number	Name and Description
R1,2,3,4,5,6	47-01-102103-01	Res., 11K Ω \pm 5%, 1/4W
R7,8,9,10,11,12	47-01-102127-01	Res., 100K Ω \pm 5%, 1/4W
R13,14,15,16,17,18,19,20,21,22,23,24	47-01-102163-01	Res., 1K Ω \pm 10%, 1/4W
R25,26,27,28,29,30	47-06-042485-02	Pot., 1M Ω
S1,2,3,4,5,6	51-02-119053-01	Switch, 3P3T, rocker
S7	51-02-113178-01	Switch, DPDT
T1	56-08-007397-04	Transformer, power
TB1	21-04-101034-01	Terminal board, 2-terminal
TB2	21-04-101013-01	Terminal board, 5-terminal

SUMMING AND POWER PCB ASSEMBLY

Reference Designator	Ordering Number	Name and Description
C1,3	15-01-107452-01	Cap., 10 μ F, 50V
C2	15-02-107455-01	Cap., 47 pF \pm 10%, 100V
C4	15-01-100236-01	Cap., 50 μ F, 25V
C5	15-01-107485-01	Cap., 1000 μ F, 25V
C6,7	15-01-114480-01	Cap., 1000 μ F, 35V
CR1,2,3	48-02-042787-01	Rect., silicon, 1A, 400V PIV
IC1	17-01-118679-01	Integrated circuit, 18V, Fairchild UGH 7818393
Q1,2	48-03-109714-01	Transistor, TZ81
Q3	48-03-108557-03	Transistor, 2N5367, selected
R1,2,3,4,5,6	47-01-102101-01	Res., 9.1K Ω \pm 5%, 1/4W

Reference Designator	Ordering Number	Name and Description
R7	47-01-102190-01	Res., 180K Ω \pm 10%, 1/4W
R8	47-01-102187-01	Res., 100K Ω \pm 10%, 1/4W
R9	47-01-102075-01	Res., 750 Ω \pm 5%, 1/4W
R10,15	47-01-102175-01	Res., 10K Ω \pm 10%, 1/4W
R11	47-01-102159-01	Res., 470 Ω \pm 10%, 1/4W
R12	47-01-102154-01	Res., 180 Ω \pm 10%, 1/4W
R13	47-01-102145-01	Res., 33 Ω \pm 10%, 1/4W
R14	47-01-102157-01	Res., 330 Ω \pm 10%, 1/4W
R16,17	47-01-102140-01	Res., 10 Ω \pm 10%, 1/4W



LISTED
209J