

ALTEC®

1593B AMPLIFIER

OPERATING INSTRUCTIONS



NOTICE

Read this manual before operating
the ALTEC 1593B Power Amplifier.

FEATURES

- 50 Watts of Output Power at Less than 1% THD from 45 Hz to 20 kHz
- Transformer-Isolated Outputs for 4, 8 and 16 Ohms and for 70.7V Distribution Systems
- Switchable Highpass Filter Protects Driver Loudspeaker from Excessive Low-Frequency Power Demands
- Exclusive *Active Dissipation Sensing Circuit* Protects Output Transistors
- AC or Battery Operation
- Safety – Underwriters' Laboratories Listed
- Automatic Transfer to Battery Operation if AC Power Fails
- Low Power Consumption
- Low Heat Generation
- Hinged Front Panel for Easy Maintenance
- Small Size
- Light Weight

Specifications and components subject to change without notice. Overall performance will be maintained or improved.

ALTEC®

SOUND PRODUCTS DIVISION

1515 S. Manchester Ave., Anaheim, Calif. 92803

42-02-042140-05

Litho in USA CP-475-2.5K

DATA CONTENTS

Item	Page
SPECIFICATIONS	3
DESCRIPTION	4
ACCESSORIES	4
INSTALLATION	4
RACK INSTALLATION	4
SHELF INSTALLATION	4
VENTILATION	4
ELECTRICAL	5
120 Volt, 50/60 Hz Power Connections	5
240 Volt, 50/60 Hz Power Connections	5
Battery Connections	6
Input Connections	6
Output Connections	7
Speaker Matching	7
Speaker Power Distribution	7
OPERATION	7
CONTROLS AND INDICATORS	7
HIGHPASS FILTER	7
SERVICE	7
ACCESS	7
ADJUSTMENT OF POWER DRIVER	
BALANCE CONTROL	7
ADJUSTMENT OF OUTPUT "Q"	
BALANCE CONTROLS	8
ASSEMBLY REPLACEMENTS	8
Fuses	8
Pilot Lamp	8
Power Driver PCB	8
RECOMMENDED SERVICE TECHNIQUES	8
Transistor Orientation	8
Replacing Power Transistors	9
Testing Transistors	9
Replacing PCB Components	9
Repairing Fractured or Damaged PCB Conductor	9
PARTS LIST	13
MAIN CHASSIS	13
POWER DRIVER PCB ASSEMBLY	14

Graphics	Page
Figure 1. Typical Power Output Versus Frequency for 1% THD (4-Ohm Load)	3
Figure 2. Typical % THD Versus Frequency for 50-Watt Output	3
Figure 3. Front View With Hinged Panel Open	4
Figure 4. Rear View of 1593B Power Amplifier	5
Figure 5. Converting to 240V ac, 50/60 Hz Operation	6
Figure 6. Socket Wiring for Transformer-Isolated Input Using 15095A Line Transformer	6
Table I. Terminals and Applications of INPUT Terminal Board	6
Table II. Speaker Outputs	7
Figure 7. Typical Solid-State Component Configurations	9
Figure 8. Component Locations Inside Main Chassis	10
Figure 9. Component Locations on Rear of Chassis	10
Figure 10. Schematic (2D356-7), 1593B Power Amplifier	11
Figure 11. Component Locations (2C364-4), Power Driver PCB Assembly	12

SPECIFICATIONS

Type:	Power Amplifier
Gain:	61 dB
Input Sensitivity:	0.8V rms direct 0.8V rms with 15335A line transformer 0.15V rms with 15095A line transformer
Power Output:	50 watts at less than 1 percent THD 45 – 20,000 Hz (see Figure 1)
Frequency Response:	±1 dB, 20 – 20,000 Hz
Input Impedance:	15,000 ohms direct 15,000 ohms balanced with 15335A line transformer 600 ohms balanced with 15095A line transformer
Load Impedance:	4, 8, 16, 100 ohms
Load Voltage:	14, 20, 28, 70 volts
Output Impedance:	Less than 10 percent of nominal load impedance
Noise Level:	-38 dBm; 85 dB below rated output

Controls:	Potentiometer, continuously variable
Power Supply:	120/240 volts 50/60 Hz 13 watts at zero signal 85 watts at 17 watts output 145 watts at 50 watts output — or — 24/28 volts dc 0.2 amp at zero signal 2.5 amp at 17 watts output 4.0 amp at 50 watts output battery minus (-) is ground
Operating Temperature Range:	Up to 55°C ambient
Dimensions:	5-1/4" H x 19" W x 7-3/8" D
Weight:	23 pounds
Color:	ALTEC Green
Accessories:	15095A Plug-In Line Transformer 15335A Plug-In Bridging and Matching Transformer

NOTE
Accessories must be ordered separately.

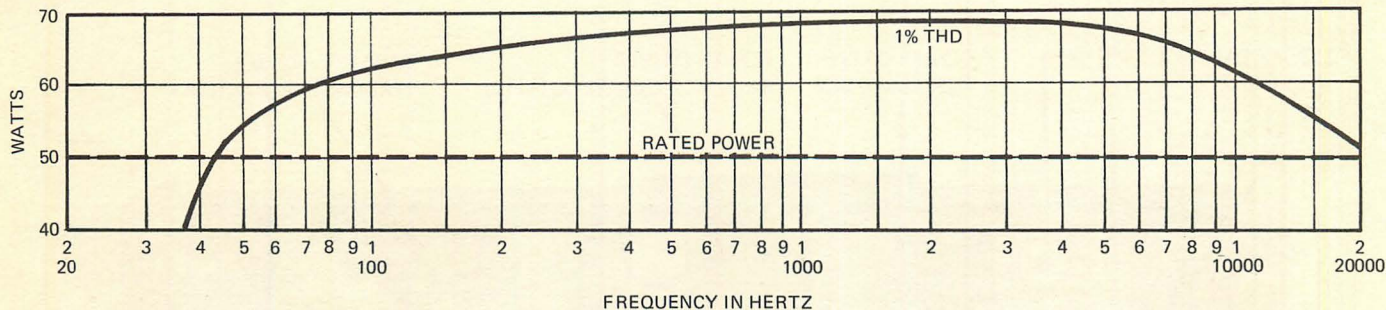

Figure 1. Typical Power Output Versus Frequency for 1% THD (4-Ohm Load)

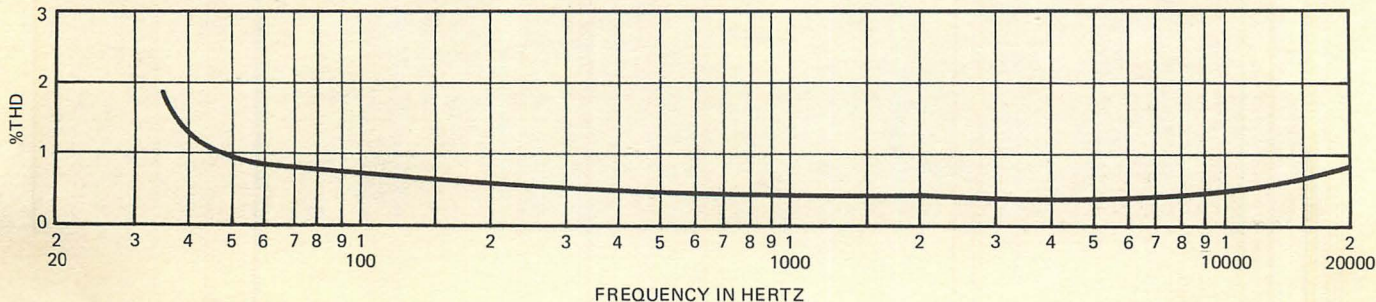

Figure 2. Typical % THD Versus Frequency for 50-Watt Output

DESCRIPTION

The ALTEC 1593B Power Amplifier delivers up to 50 watts of output power for all types of sound reinforcement systems. It remains stable with operating conditions of varying line voltages and with all types of loads, including long, unloaded speaker lines having considerable capacitance. Performance characteristics are shown in Figures 1 and 2.

A switchable, two-section highpass filter is provided to protect driver loudspeakers from excessive low-frequency power demands.

ALTEC's Active Dissipation Sensing Circuit provides fail-safe protection for the output transistors. Circuit action is immediate and effective at all frequencies within the pass-band of the amplifier, limiting only that portion of program material that would damage or degrade the output transistors.

ACCESSORIES

A plug-in 15095A or 15335A Line Transformer is available to provide line isolation. Input sensitivity for full-rated amplifier output is 0.2V rms with the 15095A Transformer and 0.8V rms with the 15335A Transformer.

The 42526 Shelf Mount Cover is available to enclose the 1593B for shelf use. It tilts the 1593B for easy access to front panel controls. The sides and top extend beyond the front panel to prevent accidental changes of control settings. The cover provides easier handling for portability and it is

sturdy enough to support lightweight equipment placed on top of it. Four polyethylene feet prevent marring of surfaces. The ALTEC green finish matches the front panel of the 1593B.

INSTALLATION

The 1593B may be installed in a standard 19-inch equipment rack, or in the 42526 Shelf Mount Cover accessory for shelf use. Vertical space required is 5¼ inches (3 rack units).

RACK INSTALLATION

- Step 1. Remove four screws securing front panel. Open and lower panel as shown in Figure 3.
- Step 2. Install 1593B in equipment rack with appropriate four screws supplied.
- Step 3. Close front panel and secure with four screws previously removed.

SHELF INSTALLATION

The 1593B may be shelf mounted as desired after installing the ALTEC 42526 Shelf Mount Cover (refer to 42526 Installation Instructions).

VENTILATION

The 1593B generates minimal heat during normal use. Although the amount of heat is relatively low, the amplifier

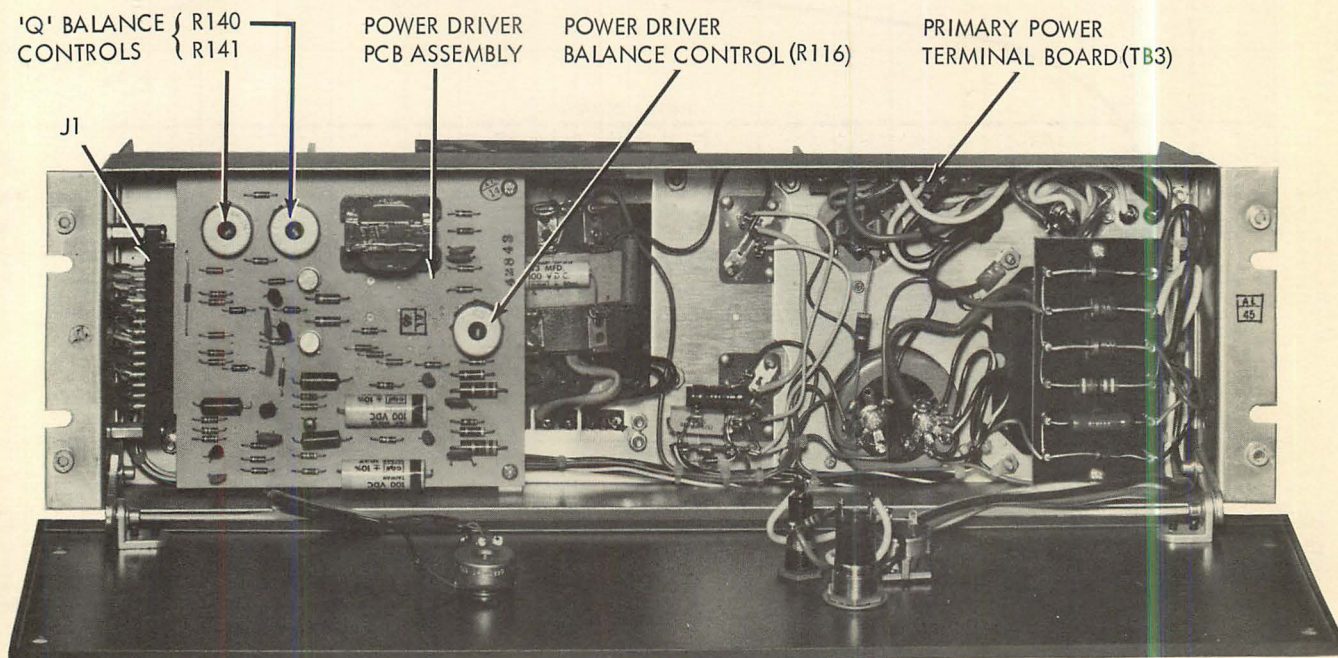

Figure 3. Front View With Hinged Panel Open

must be ventilated to prevent an excessive temperature rise. Because transistors are heat sensitive, the 1593B should not be placed adjacent to heat-generating equipment or in areas where ambient temperature exceeds 55°C (131°F).

If the 1593B is installed in an equipment rack or cabinet with other heat-producing equipment installed above and/or below (two or more 1593B's or one 1593B with real time analyzer, oscilloscope, etc.), space must be provided between the units or the 1593B may become too warm. The 1-3/4" perforated panel (ALTEC Part No. 10399) is recommended for this purpose. When several amplifiers or other heat-producing units are installed in a single rack or cabinet, acceptable air temperature may be in doubt. To determine temperature conditions, operate the system until temperature stabilizes, then measure air temperature with a bulb-type thermometer held at the bottom of the uppermost amplifier. Do not let the thermometer bulb touch metal because the metal probably will be hotter than the ambient air. If air temperature exceeds 55°C (or if it is a hot day), the equipment should be spaced farther apart or a blower should be installed to ventilate the cabinet.

CAUTION

Do not block the cover ventilation holes when placing other equipment on the 42526 Shelf Mount Cover accessory. When shelf-mounting the 1593B, allow at least 1-3/4" between the unit and any wall behind it to assure air circulation past the output transistors.

ELECTRICAL

120 Volt, 50/60 Hz Power Connections

Equipment supplied for domestic use is provided with the power transformer primary strapped for 120 volts (terminals

1 to 2 and 3 to 4 on TB3). The power input nameplate, adjacent to the power cord on the chassis, is mounted to show the appropriate side specifying the connections (see Figure 4). Verify that line voltage is in accordance with the voltage rating before connecting the 1593B to line power.

240 Volt, 50/60 Hz Power Connections

Export equipment is provided with the power transformer primary strapped for 240 volts (terminals 2 to 3 on TB3). The power input nameplate, adjacent to the power cord on the chassis, is mounted to show the appropriate side specifying the connections.

For a 1593B previously wired for 120V ac primary power, use the following procedure to change wiring for 240V ac, 50/60 Hz operation:

- Step 1. Remove four screws securing front panel, open and lower panel.
- Step 2. Locate terminal board TB3 (see Figure 3).
- Step 3. Remove strap "A" connecting terminals 1 and 2 and remove strap "B" connecting terminals 3 and 4; solder strap "C" to terminals 2 and 3 (see Figure 5).
- Step 4. Remove voltage-rating plate (see Figure 4) from chassis, reverse and reinstall to show 240V ac rating.
- Step 5. Close front panel and secure with four screws previously removed.

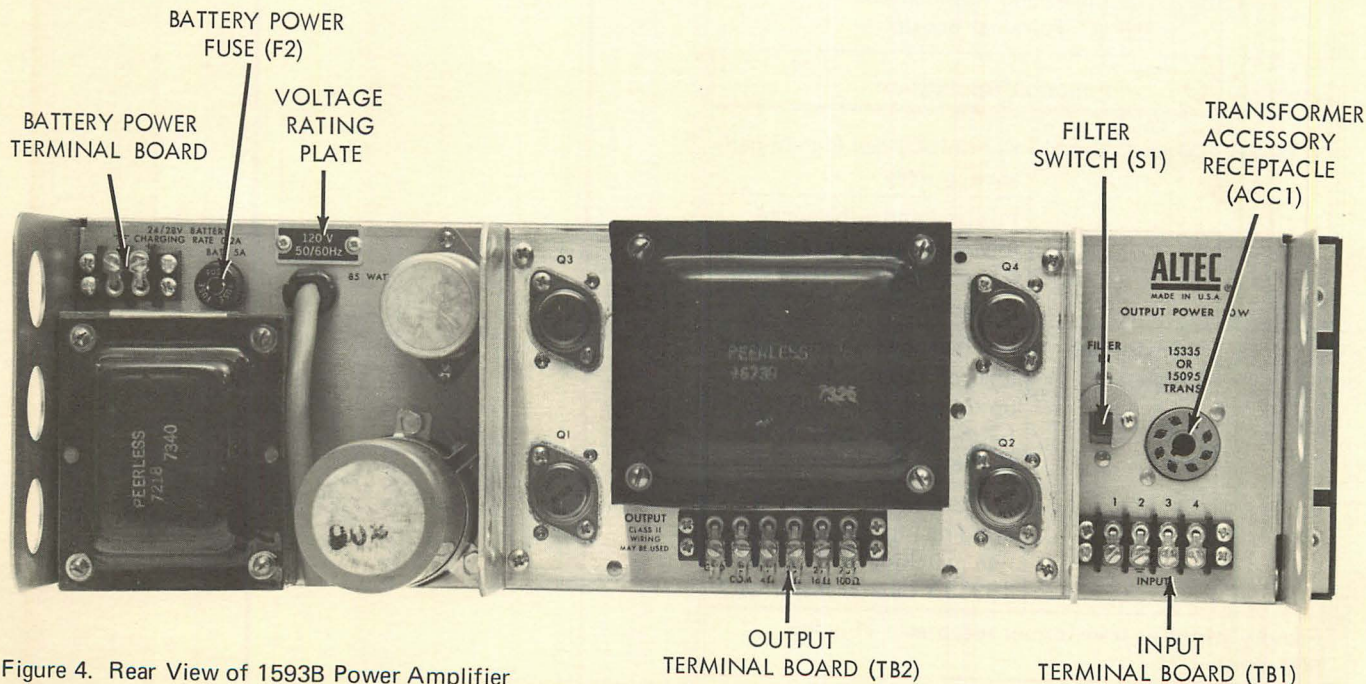

Figure 4. Rear View of 1593B Power Amplifier

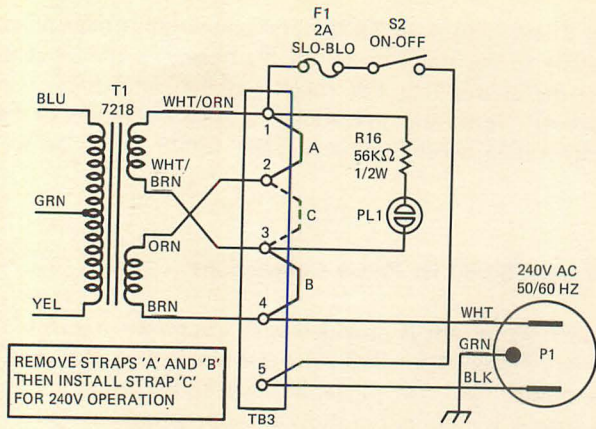

Figure 5. Converting to 240V ac, 50/60 Hz Operation

Battery Connections

If desired, the 1593B may be connected to an external 24/28 volt battery with minus (-) as ground. Terminals for the dc power connections are on TB4 (see Figures 4 and 10). If ac power fails, transfer to dc power is instantaneous, automatic and silent. A built-in charging circuit supplies a 100 mA trickle current to maintain battery charge during ac operation. The battery power supply is not operated by the primary power ON-OFF switch on the front panel. If switching of battery power is desired, an external relay or switch should be provided by the user.

Input Connections

Input connections may be either direct-coupled or transformer-isolated at the INPUT terminal board (see Figure 4). Direct coupling is accomplished by connecting the input leads (shielded conductor recommended) to terminals 1 and 2. Terminal 2 is ground. Table I lists the terminals and applications of the INPUT terminal board.

Table I. Terminals and Applications of INPUT Terminal Board

Terminals	Function/Application	
1,2 (GND)	Direct-Coupled	For unbalanced high-impedance sources
		For bridging unbalanced low-impedance lines having signal voltages of 0.8V rms or higher
3,4	Transformer-Isolated	For balanced or unbalanced lines of 150 or *600 ohms up to level of +15 dBm (with 15095A Line Transformer)
		For low-impedance line-bridging input or 15K ohm line-matching input (with 15335A Line Transformer)
* Factory wiring at transformer receptacle J1 is for 600 ohms		

For transformer-isolated input, a plug-in 15095A or 15335A Line Transformer must be plugged into receptacle J1 (see Figure 4). The input leads are connected to terminals 3 and 4 of the INPUT terminal board.

When shipped from the factory, pins 3 and 4 of J1 are strapped together to provide a 600-ohm input. A 150-ohm input may be obtained by removing the strap from pins 3 and 4 and then strapping pins 1 and 4 and pins 3 and 6 (see Figure 6).

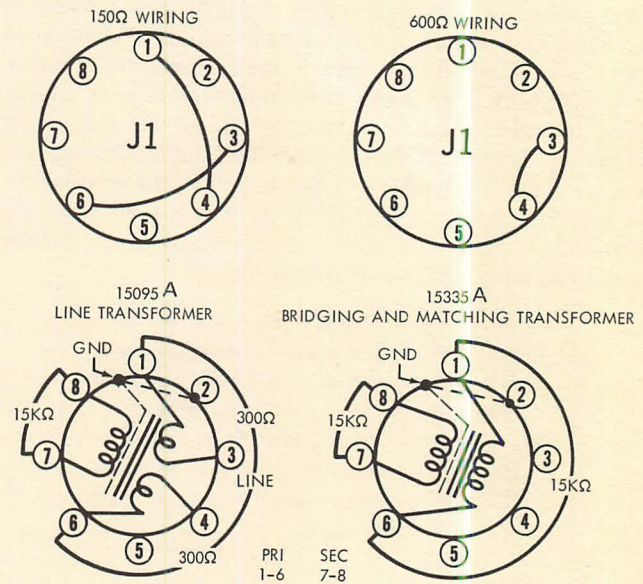

Figure 6. Socket Wiring for Transformer-Isolated Input Using 15095A Line Transformer

Output Connections

Output transformer taps provide connections for 4-ohm, 8-ohm and 16-ohm speakers, plus a 70.7-volt speaker distribution system (see Figure 4). For 25-volt speaker distribution systems, use the 16-ohm tap. Connect to the terminal of desired impedance and terminal 5 (common). Terminal functions and designations are listed in Table II. If stray electrostatic radiation causes interference, strap terminal 5 (common) to terminal 6 (ground).

CAUTION

When using stranded wire, be sure no frayed wire strands short circuit one terminal to another terminal.

Table II. Speaker Outputs

Terminal	Function
70V	70.7V (100 ohms) speaker distribution systems
16 Ω	16 ohms (28V) speaker systems. May be used for 25V speaker distribution systems.
8 Ω	8 ohms (20V) speaker systems
4 Ω	4 ohms (14V) speaker systems
COM	Common
GND	Ground

Speaker Matching

Use the output tap most nearly equal to total speaker impedance. If the load impedance falls between two output terminal values, use the terminal of lower impedance.

Speaker Power Distribution

Total power distributed to all speakers should be not greater than the power rating of the amplifier system. The 70.7V distribution outlet permits connection to a large number of speakers, each speaker operating at its required power level. Computing impedance is not necessary for this application. Each speaker is equipped with a line transformer having various power taps. Select the tap which yields the power desired for that speaker.

OPERATION

CONTROLS AND INDICATORS

Two operating controls are on the front panel; a VOLUME control and a primary power ON-OFF switch. A pilot indicator is lit when the power is ON.

HIGHPASS FILTER

A two-section highpass filter is provided with the 1593B to protect driver loudspeakers from excessive low-frequency

power demands. Filter use is indicated when high power output from the amplifier is applied to driver loudspeakers not equipped with protective crossover networks. The 3 dB frequency of the highpass filter is approximately 400 Hz.

A FILTER IN-OUT switch is located on the rear of the chassis (see Figure 4). The switch is placed in the OUT position when the 1593B is shipped from the factory.

SERVICE

If a malfunction occurs, service should be performed by an ALTEC Qualified Service Representative. For factory service, ship the 1593B prepaid to Customer Service, ALTEC, 1515 South Manchester Avenue, Anaheim, California 92803. For additional information or technical assistance, call (714) 774-2900, or TWX 910-591-1142.

Main chassis component locations are shown in Figures 8 and 9. The 1593B schematic is shown in Figure 10. Component locations on the Power Driver PCB are shown in Figure 11.

ACCESS

Remove the four screws securing the front panel, then open and lower the hinged front panel to gain access to the chassis interior.

If the ALTEC 42526 Shelf Mount Cover accessory is installed, remove by reversing the steps of the cover installation procedure given in the associated instructions.

ADJUSTMENT OF POWER DRIVER BALANCE CONTROL

The Power Driver Balance Control (R116 on Power Driver PCB), balances the outputs of transistors Q104 and Q105 on the PCB. If this control is not adjusted properly, high-frequency distortion results. If adjustment is indicated, use the following procedure:

- Step 1. Connect a 16-ohm dummy load across 16 Ω and COM (common) terminals of TB2 (see Figure 10).
- Step 2. Apply a 20 kHz sine wave to terminals 1 and 2 of the INPUT terminal board (TB1).
- Step 3. Adjust VOLUME control for 50-watt output (28 volts).
- Step 4. Connect a frequency distortion analyzer (preferred) or an oscilloscope to 16 Ω terminals (16-ohm speaker output) of OUTPUT terminal board and observe output.
- Step 5. Remove four screws securing front panel, then open and lower panel.

- Step 6. Adjust R116 on Power Driver PCB (see Figures 3 and 10) until minimum distortion is observed on distortion measuring instrument.
- Step 7. Close front panel and secure with four screws previously removed.

ADJUSTMENT OF OUTPUT "Q" BALANCE CONTROLS

Output "Q" Balance Controls R140 and R141 on Power Driver PCB (see Figure 3) balance the bias current of power transistors Q1, Q2, Q3 and Q4. Inadequate adjustment of these controls may result in distortion and excessive current drain from one or more power transistors. If adjustment is indicated (such as replacement of one or more power transistors), use the following recommended procedure:

- Step 1. Turn VOLUME control fully counterclockwise (0).
- Step 2. Remove four screws securing front panel, then lower panel for access to interior.

CAUTION

High voltage may be encountered when the chassis is opened for service. This procedure should be referred to a qualified service technician.

- Step 3. Turn Output "Q" Balance Controls R140 and R141 fully clockwise (see Figure 3).
- Step 4. Turn on power and allow a 5-minute warmup period.
- Step 5. Adjust R140 and R141 by one of the following methods [method (a) is preferred]:
- Locate wire attached to terminal 1 of output transformer T2. Connect a clamp-on milliammeter to this wire and adjust R140 counterclockwise for a "Q" current of 30 mA. Change connection of milliammeter to wire attached to terminal 3 of output transformer T2 and adjust R141 for a "Q" current of 30 mA.
 - Remove two screws securing Power Driver PCB to chassis and lower PCB on hinged connector. Connect a millivoltmeter across resistor R4 (see Figure 8), starting with highest scale to protect meter. Adjust R140 for meter reading of 10 mV. Change connection of millivoltmeter to read across resistor R5 and adjust R141 for meter reading of 10 mV. Remove millivoltmeter and secure PCB to chassis with two screws previously removed.
- Step 6. Close front panel and secure with four screws removed in Step 2.

ASSEMBLY REPLACEMENTS

Fuses

The ac primary power fuse is mounted on the front panel (see cover photo). The battery power fuse is located on the rear of the chassis (see Figure 4). If fuse replacement is required, determine and correct any cause of failure before replacing fuse. Install an identical fuse (see **PARTS LIST**) by unscrewing fuse holder, replacing fuse and resealing fuse holder.

Pilot Lamp

The pilot lamp is located on the front panel (see cover photo). If replacement is required, unscrew the red pilot lamp shield to expose the bulb. Press bulb inward and turn counterclockwise (ccw) to remove. Install an identical bulb (see **PARTS LIST**), then replace red pilot-lamp shield.

Power Driver PCB

If the amplifier fails because of a faulty power driver PCB, operation may be restored by replacing the PCB with a new or repaired PCB. Use the following procedure.

- Step 1. Remove four screws securing front panel. Open and lower panel for access to PCB (see Figure 3).
- Step 2. Remove two screws securing PCB to chassis brackets.
- Step 3. Carefully remove PCB from connector.
- Step 4. Carefully insert new or repaired power driver PCB into connector. **Do not** warp, bend or twist the board or conductor may fracture.
- Step 5. Secure PCB with two screws removed in Step 2.
- Step 6. Perform ADJUSTMENT OF POWER DRIVER BALANCE CONTROL procedure.

RECOMMENDED SERVICE TECHNIQUES

If systematic troubleshooting shows need for parts replacement, observe the following precautions.

Transistor Orientation

Solid-state components are packaged in various case sizes and types with various lead orientations (see Figure 7). Before removing a solid-state component from tie points or from a PCB, sketch the lead orientation with respect to the tie points or PCB.

Form the leads of the new component to conform with the leads of the part being replaced to aid in making proper connections. Before removing small transistors, note position of index tab with respect to the PCB or socket. Cut the leads of the new transistor to the required length and insert them, properly indexed, into the PCB or socket.

Replacing Power Transistors

Verify the following conditions exist when replacing power transistors.

1. Mica insulator is not damaged. If damaged, use new insulator.
2. No grit or metal particles are between transistor and heat sink.
3. Both sides of mica insulator are covered with silicone grease or fluid.
4. Mounting screws are tight.

Testing Transistors

Transistors should be checked with a transistor tester. If a tester is not available, use the following procedure for testing transistors with an ohmmeter.

- Step 1. Remove suspected transistor from circuit (see Replacing PCB Components).

NOTE

Transistors may be tested while still in the circuit; however, the nominally accepted 10 :: 1 resistance ratio for 'front-to-back' measurements may be lower.

- Step 2. Connect ohmmeter leads to base and emitter. Read on lowest ohms scale. Reverse leads and read again. Normal readings should be at least 10 times greater in one direction than in the other.
- Step 3. Connect ohmmeter leads to base and collector. Ohmmeter readings should be similar to those obtained in Step 2.
- Step 4. If Steps 2 and 3 show normal function, connect ohmmeter leads to collector and emitter. Read on lowest ohms scale. Reverse leads and read again. If reading is low and virtually unchanged

when ohmmeter leads are reversed, the transistor has a short circuit between collector and emitter.

Replacing PCB Components

Before removing PCB components for testing or replacement, read and perform the following instructions.

1. Solid-state components and PCB's may be damaged by excessive heat. Use a small soldering iron with a 1/8-inch diameter chisel tip and use small-diameter 60/40 rosin-cored solder.
2. Remove components by placing soldering iron on component lead on **conductor** side of PCB and pull out lead. Avoid overheating the conductor.

CAUTION

The conductor on the PCB is a metal surface plated with solder and laminated to the board. Too much pressure or overheating may lift the conductor from the board.

3. If component is faulty or damaged, clip leads close to component and then unsolder leads from board. Withdraw leads from **component** side.
4. Clear solder from circuit board holes before inserting leads of new component. Heat solder remaining in hole, remove iron and quickly insert a pointed non-metallic object, such as a toothpick, from **conductor** side.
5. Shape new component leads and clip to proper length. Lead shape should provide stress relief for component. Insert leads in holes, observing same polarity or orientation of removed component. Apply heat and solder on **conductor** side.

Repairing Fractured or Damaged PCB Conductor

If a conductor is fractured, damaged or lifted from the circuit board, a recommended method of repair is to solder a section of good conducting wire along the damaged area and then seal with epoxy.

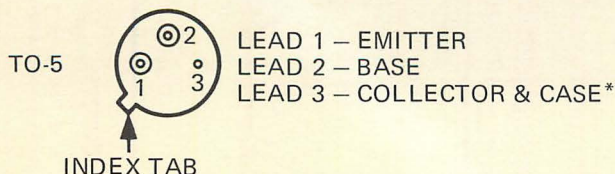

*NOT ALL TYPES. SOME HAVE BASE-TO-CASE INTERNALLY; OTHERS HAVE NO CONNECTION TO CASE.

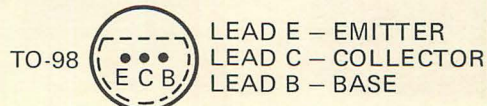
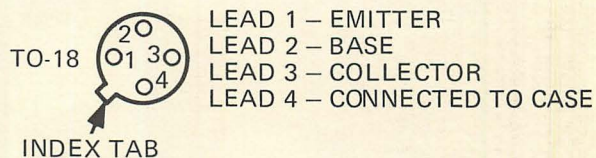

Figure 7. Typical Solid-State Component Configurations

POWER DRIVER
PCB ASSEMBLY
REMOVED
(SEE FIGURES 3, 12)

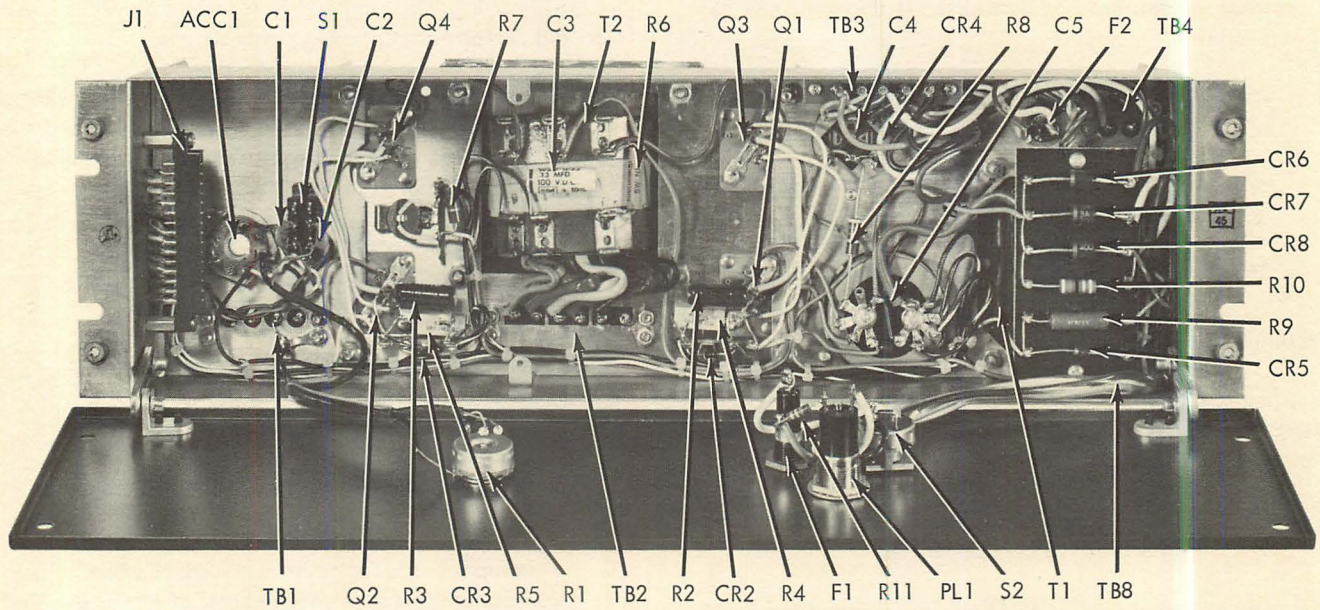

Figure 8. Component Locations Inside Main Chassis

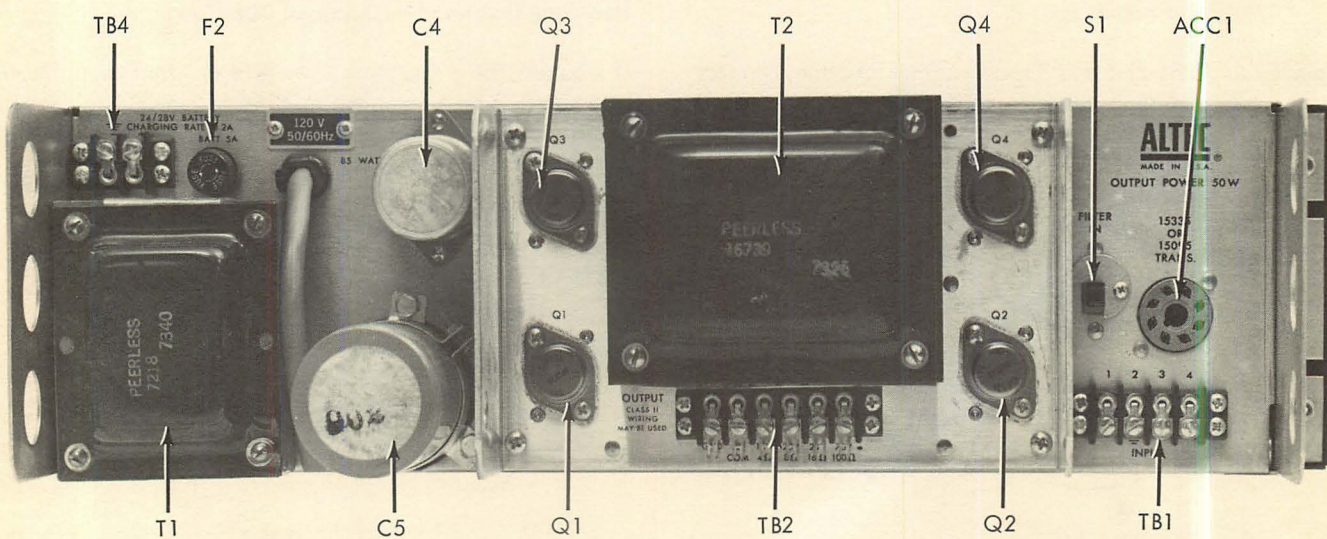
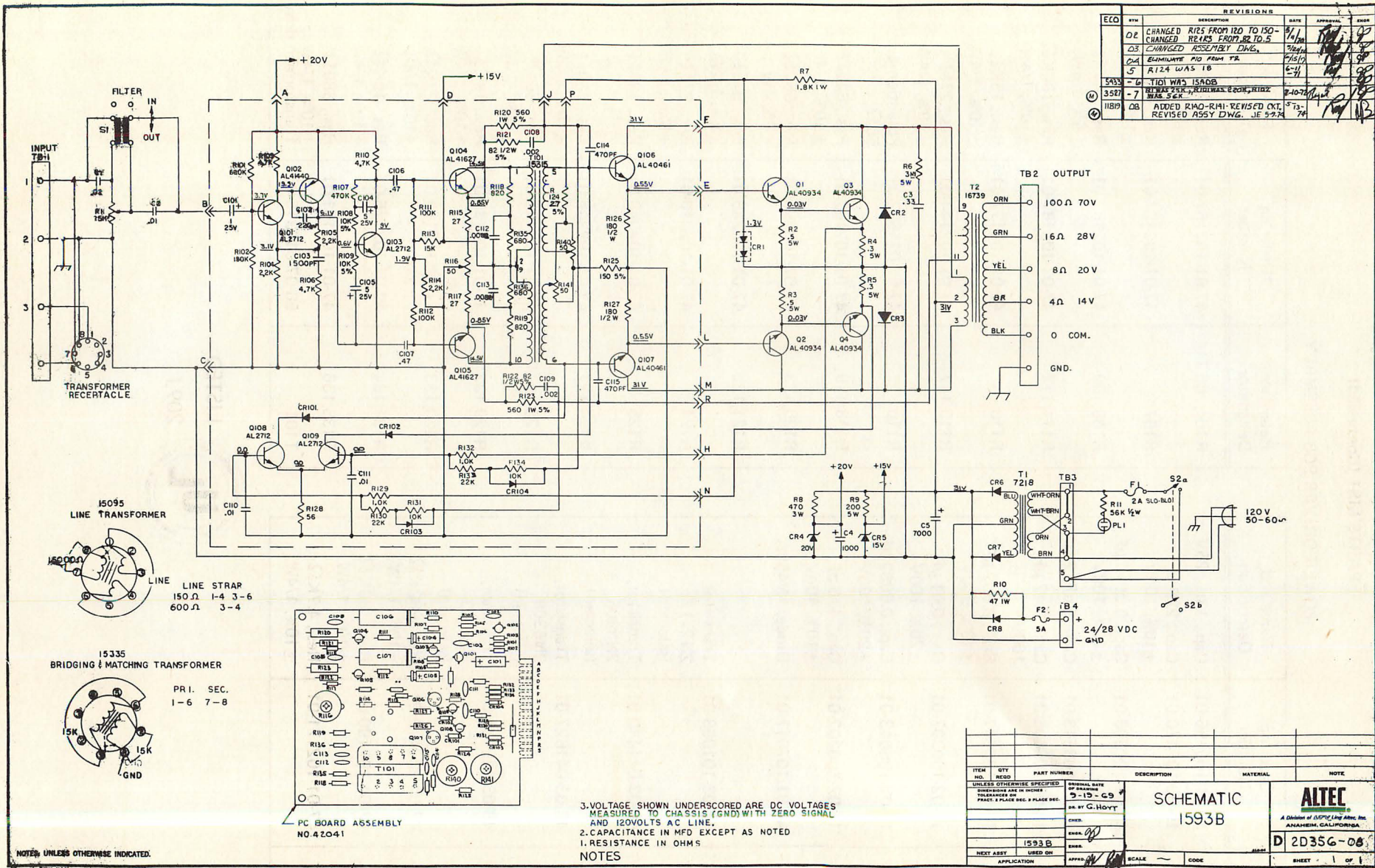
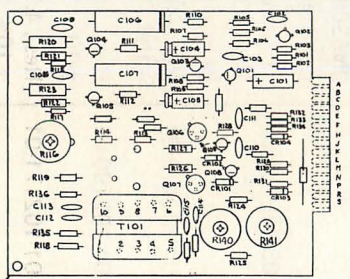
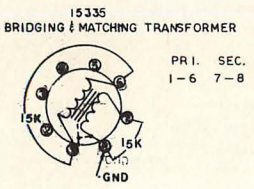
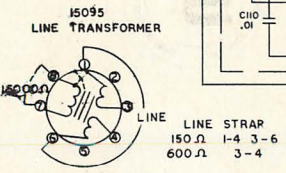

Figure 9. Component Locations on Rear of Chassis



REVISIONS					
ECO	BY	DESCRIPTION	DATE	APPROVAL	DRG
02		CHANGED R125 FROM 150 TO 150.5	9/1		
03		CHANGED REPAIRS FROM PR TO 2.5	9/1		
04		EXAMINATE PID FROM TR	7/15/74		
05		R124 WAS 18	6-11		
5433		T101 WAS 1540B			
3527		REPLACES P101, REPAIR MAX 20V, R102 WAS 5.6K	2-10-74		
3189		ADDED R100-R101-REVISED CMT, REVISED ASSY DWG. JE 5-7-74	5-7-74		

- 11 -



3. VOLTAGE SHOWN UNDERScoreD ARE DC VOLTAGES MEASURED TO CHASSIS (GND) WITH ZERO SIGNAL AND 120VOLTS AC LINE.
2. CAPACITANCE IN MFD EXCEPT AS NOTED
1. RESISTANCE IN OHMS
NOTES

ITEM NO.	QTY	RESO	PART NUMBER	DESCRIPTION	MATERIAL	NOTE
UNLESS OTHERWISE SPECIFIED:						
				RESISTORS ARE IN OHMS	BY G. HOYT	
				TRANSFORMERS ARE IN INCHES		
				PRINT. & PLACE DEC. & PLACE DEC.		
				1593B		
				NEXT ASSY USED ON		
				APPLICATION		

SCHEMATIC
1593B

ALTEC
A Division of MDC/Link, Inc.
ANAHEIM, CALIFORNIA

D 20356-08	SCALE ~ CODE
SHEET 1 OF 1	

Figure 10. Schematic (2D356-7), 1593B Power Amplifier

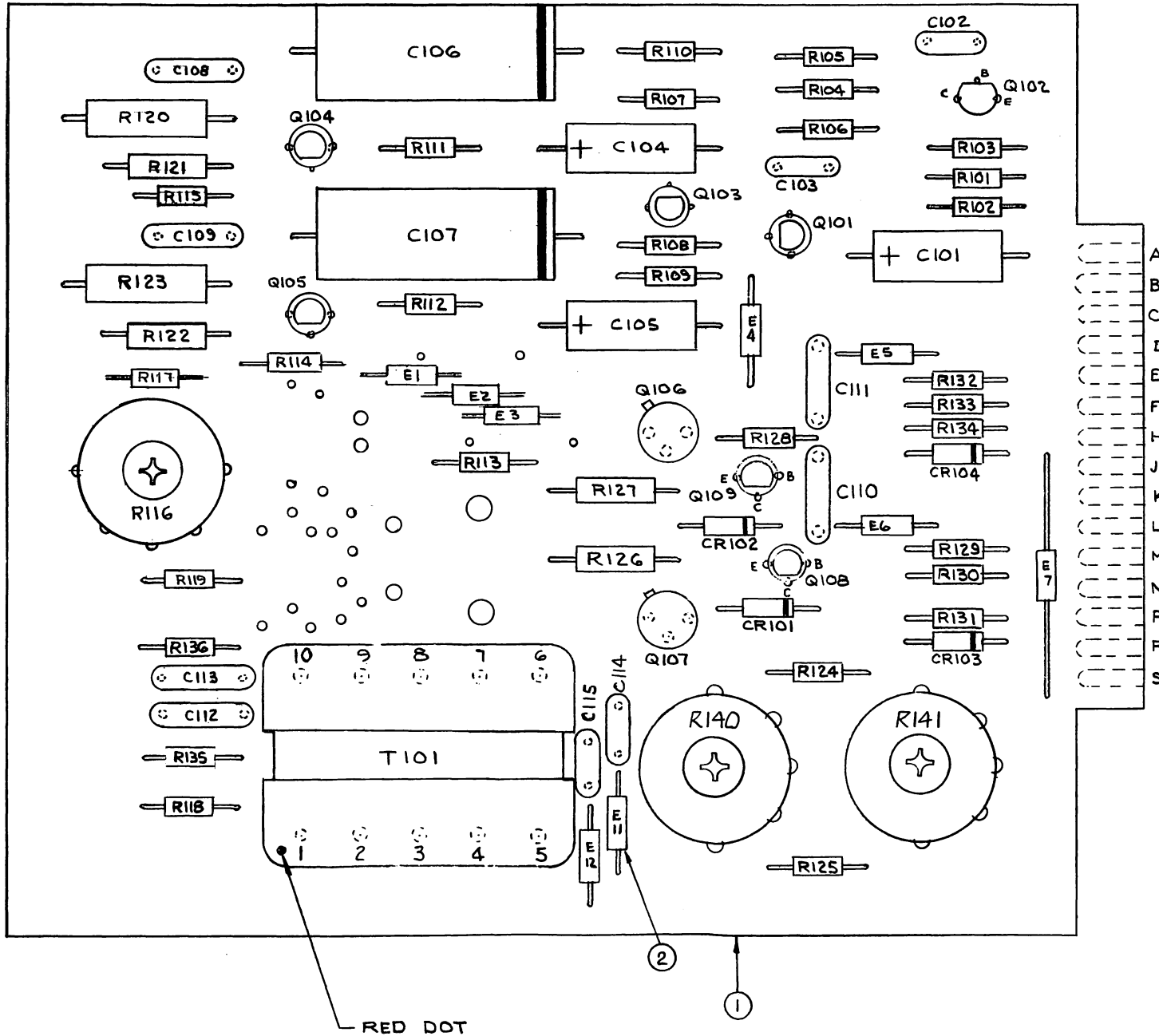

Figure 11. Component Locations (2C364-4), Power Driver PCB Assembly

PARTS LIST
MAIN CHASSIS

Reference Designator	Ordering Number	Name and Description
A1	27-01-042041-01	Amplifier PCB Assembly
C1	15-02-100087-01	Cap., 0.02 μ F \pm 20%, 100V
C2	15-02-100307-01	Cap., 0.01 μ F \pm 20%, 100V
C3	15-06-100139-01	Cap., 0.33 μ F \pm 10%, 100V
C4	15-01-100284-01	Cap., 1000 μ F, 35V
C5	15-01-119405-01	Cap., 7000 μ F, 40V
CR1	48-01-100881-01	Diode, stabistor, STB567
CR2,3	48-01-102592-01	Diode, 1N4004 (selected)
CR4	48-01-107271-01	Diode, LMZ 20A
CR5	48-01-108576-01	Diode, LMZ 15A
CR6,7,8	48-02-107467-01	Diode, rectifier, 1N542
F1	51-04-110782-01	Fuse, 2A, 3AG
F2	51-04-100470-01	Fuse, 5A, 3AG
PL1	39-03-100793-01	Pilot light assembly
Q1,2,3,4	48-03-040934-02	Transistor, 2N6254 (selected)

Reference Designator	Ordering Number	Name and Description
R1	47-06-042509-1	Potentiometer, 15K Ω
R2, 3	47-02-108440-01	Res., 0.5 Ω \pm 10%, 5W
R4, 5	47-02-108691-01	Res., 0.3 Ω \pm 10%, 5W
R6	47-02-109388-01	Res., 3 Ω \pm 10%, 5W
R7	47-01-100652-01	Res., 1.8K Ω \pm 10%, 1W
R8	47-01-102551-01	Res., 470 Ω \pm 5%, 3W
R9	47-02-100715-01	Res., 200 Ω \pm 10%, 5W
R10	47-01-100638-01	Res., 47 Ω \pm 10%, 1W
R11	47-01-102376-01	Res., 56K Ω \pm 10%, 1/2W
S1	51-02-100992-01	Switch, slide
S2	51-02-100988-01	Switch, power
T1	56-08-007218-05	Transformer, power
T2	56-07-016739-03	Transformer, output

PARTS LIST (Continued)

POWER DRIVER PCB ASSEMBLY

Reference Designator	Ordering Number	Name and Description
C101	15-01-100156-01	Cap., 1 μ F, 25V
C102	15-02-107470-01	Cap., 220 pF \pm 10%, 100V
C103	15-02-100306-01	Cap., 0.0015 μ F \pm 20%, 100V
C104,105	15-01-108543-01	Cap., 5 μ F, 25V
C106,107	15-06-102605-01	Cap., 0.47 μ F, 100V
C108,109	15-02-100047-01	Cap., 0.002 μ F \pm 10%, 500V
C110,111	15-02-100307-01	Cap., 0.01 μ F \pm 20%, 100V
C112,113	15-02-108643-01	Cap., 0.0082 μ F \pm 20%, 100V
C114,115	15-02-100302-01	Cap., 470 pF \pm 10%, 100V
CR101, 102,103, 104	48-01-107017-01	Diode, 1N456A
Q101,103, 108,109	48-03-101098-01	Transistor, 2N2712 (selected)
Q102	48-03-041440-01	Transistor, 2N3906 (selected)
Q104,105	48-03-041627-01	Transistor, 2N5308 (selected)
Q106,107	48-03-040461-02	Transistor, 2N3053 (selected)
R101	47-01-100479-01	Res., 680K Ω \pm 10%, 1/4W
R102	47-01-102190-01	Res., 180K Ω \pm 10%, 1/4W
R103,106, 110	47-01-102171-01	Res., 4.7K Ω \pm 10%, 1/4W

Reference Designator	Ordering Number	Name and Description
R104,105,114	47-01-102167-01	Res., 2.2K Ω \pm 10%, 1/4W
R107	47-01-100477-01	Res., 470K Ω \pm 10%, 1/4W
R108,109	47-01-102102-01	Res., 10K Ω \pm 5%, 1/4W
R111,112	47-01-102187-01	Res., 100K Ω \pm 10%, 1/4W
R113	47-01-102177-01	Res., 15K Ω \pm 10%, 1/4W
R115,117	47-01-102144-01	Res., 27 Ω \pm 10%, 1/4W
R116	47-05-014697-01	Potentiometer, 50 Ω
R118,119	47-01-102162-01	Res., 820 Ω \pm 10%, 1/4W
R120,123	47-01-109390-01	Res., 560 Ω \pm 5%, 1W
R121,122	47-01-102238-01	Res., 82 Ω \pm 5%, 1/2W
R124	47-01-102040-01	Res., 27 Ω \pm 5%, 1/4W
R125	47-01-102058-01	Res., 150 Ω \pm 5%, 1/4W
R126,127	47-01-102345-01	Res., 180 Ω \pm 10%, 1/2W
R128	47-01-102148-01	Res., 56 Ω \pm 10%, 1/4W
R129,132	47-01-102163-01	Res., 1K Ω \pm 10%, 1/4W
R130,133	47-01-102179-01	Res., 22K Ω \pm 10%, 1/4W
R131,134	47-01-102175-01	Res., 10K Ω \pm 10%, 1/4W
R135,136	47-01-102161-01	Res., 680 Ω \pm 10%, 1/4W
T101	56-07-015315-07	Transformer, driver



LISTED
209J